ALL-IN-WONDER™ 128 / ALL-IN-WONDER™ 128 PRO

Installation and Setup

User's Guide

Version 3.0

P/N 137-70090-30 Rev. C



© Copyright 1999, by ATI Technologies Inc.

All rights reserved, including those to reproduce this guide or parts thereof, in any form without the express written permission of ATI Technologies Inc.

Features and specifications are subject to change without notice. Trademarks and/or registered trademarks are the properties of their respective owners:

ALL-IN-WONDER 128 ALL-IN-WONDER 128 PRO, RAGE 128 – ATI Technologies Inc.;
dbx – dbx Professional Products; Macintosh – Apple Computer Inc.; Macrovision – Macrovision Corporation; Direct3D, NetMeeting, Windows 3.1x, Windows 95, Windows 98, Windows NT – Microsoft Corp.; Celeron, Indeo, Pentium, Pentium Pro – Intel Corporation; VGA – International Business Machines Corp.; VESA – Video Electronics Standards Association;
WaveTop – WavePhore WaveTop Inc.; WebTV – WebTV Networks.

Disclaimer

The manufacturer (MFR) reserves the right to make changes to this document and the products which it describes without notice. The MFR shall not be liable for technical or editorial errors or omissions made herein; nor for incidental or consequential damages resulting from the furnishing, performance, or use of this material.

The MFR makes no representation that the interconnection of products in the manner described herein will not infringe on existing or future patent rights, nor do the descriptions contained herein imply the granting of license to make, use or sell equipment constructed in accordance with this description.

The PCI accelerators have been designed to support the PCI local bus standards. Some computers use proprietary local bus circuitry and therefore may not be fully compatible with the MFR's local bus cards. Although tested successfully in a wide variety of computer systems, the MFR cannot be held responsible for any incompatibilities which may occur between this card and the system configuration you plan to use. We recommend that you check with the dealer or distributor for your computer system before installing your card.

Product Notices

Macrovision Corporation

This device is protected by U.S. Patent numbers 4,631,603,4,577,216, and 4,819,098 and other intellectual property rights.

The use of Macrovision's Copy Protection technology in the device must be authorized by Macrovision and is intended for home and other limited pay-per-view uses only, unless otherwise authorized in writing by Macrovision. Reverse engineering or disassembly is prohibited.

Dolby* Laboratories, Inc.

Manufactured under license from Dolby Laboratories. Confidential Unpublished Works. (c) 1992-1997 Dolby Laboratories, Inc. All rights reserved.

Table of Contents

Getting Started.....	5
Using this Guide	6
What is the ALL-IN-WONDER 128 Family?.....	7
System Requirements	8
Other Sources of Information	9
Readme File.....	9
Online Help	9
Online manual	10
ATI Multimedia Center Guide	10
Installing the Hardware and Software	11
Installing the Hardware	12
Windows® “New Hardware Found”	16
Installing Enhanced Drivers for Windows® 95 and Windows® 98	18
Starting the ATI Multimedia Center in Windows® 95 or Windows® 98 ..	20
Input and Output Adapters	21
Windows® 95 / Windows® 98 Volume Control	25
TV reception tips	26
Using Your ALL-IN-WONDER 128 or ALL-IN-WONDER 128 PRO.....	27
Attaching a TV to Your Card	28
Using TV Out	29
IMPORTANT INFORMATION for European Customers.....	29
Connecting your PC to a television or a VCR.....	30
Using SCART connectors for European televisions	32
Using and Adjusting TV Out.....	32
Starting Windows® with Television Display Enabled	33
Using a Monitor vs. Using the Television Display	33
Adjusting the Monitor Display	33
Viewing Text on Television	34
Reducing Edge Distortion	35
Changing Display Configurations	36
Using Games and Applications	36
For Windows® 98 Users... ..	37
Multiple Display Support in Windows® 98	38
WebTV® for Windows	39
NetMeeting™ 2.1	40

Tips and Tricks	41
Video Email.....	42
Stop-Motion Animation.....	42
Security Camera	43
Streaming video.....	43
Reference	45
Troubleshooting Tips.....	46
Basic troubleshooting tips	46
Windows® 95 / Windows® 98 troubleshooting tips	47
CD Audio Connectors	48
To Remove the ATI Multimedia Center.....	49
Japanese Users Please Note	49
Compliance Information.....	50
Index	53

CHAPTER 1

Getting Started

Welcome to the convergence of your PC, TV and video! This new technology changes the way you view TV, graphics, and video on your PC.

The ALL-IN-WONDER 128 and ALL-IN-WONDER 128 PRO are powerful TV tuners, DVD players, digital VCRs, and 2D & 3D graphics and video accelerators. Their features will take your PC's graphics and video capabilities to the next level.

This guide provides all the information you need to install your ALL-IN-WONDER 128 or ALL-IN-WONDER 128 PRO.



IN THIS CHAPTER...

- **Using this Guide** on page 6
- **What is the ALL-IN-WONDER 128 Family?** on page 7
- **System Requirements** on page 8
- **Other Sources of Information** on page 9

Using this Guide

The organization of this guide is as follows:



Installing the Hardware and Software on page 11 provides instructions on connecting video input and output devices to your ALL-IN-WONDER 128 or ALL-IN-WONDER 128 PRO.



Using Your ALL-IN-WONDER 128 or ALL-IN-WONDER 128 PRO on page 27 explains how you can take advantage of the advanced new features of the ALL-IN-WONDER 128 and ALL-IN-WONDER 128 PRO.



For Windows® 98 Users... on page 37 describes Windows® 98 features available with your ALL-IN-WONDER 128 or ALL-IN-WONDER 128 PRO.



Tips and Tricks on page 41 presents some exciting new ways to use your card—video email, stop-motion animation, and more.



Reference on page 45 provides troubleshooting tips and specifications for your card.



User Guide: The **ATI Multimedia Center User's Guide** that came with your card explains how to use the special features that the ATI Multimedia Center provides.

What is the ALL-IN-WONDER 128 Family?

The ALL-IN-WONDER 128 family of cards delivers high-performance 3D and 2D graphics, as well as advanced multimedia features. You can play games, watch TV or videos, listen to audio CDs, explore the Internet, and work in Windows[®] 95 or Windows[®] 98 as never before.

The ALL-IN-WONDER 128 family's advanced 3D acceleration gives you detailed color graphics and 3D features like multi-texturing, alpha blending, and fog effects.

The ALL-IN-WONDER 128 family also provides powerful 2D graphics features through the Display Properties pages:

Settings	Customize your desktop settings such as desktop size, screen resolution and color depth, and store various desktop preferences for easy recall later.
Adjustment	Adjust the position and size of your screen, as well as manipulate the screen refresh rate, frequencies and synchronization.
Color Correction	Correct color tone differences between real color values and the way your monitor displays them, and store various color correction preferences for easy recall later.

For comprehensive online information on the above features, just right-click on your desktop, click **Properties**, select the tab you want help for, then click the **Help** button.

ATI's RAGE 128 PRO accelerator chips provide advanced 3D support and accelerated 2D graphics. Games and software applications that support the RAGE 128 PRO — including Direct3D applications — run with fluid motion and in brilliant color.

The ALL-IN-WONDER 128 family is a part of ATI's legendary series of graphics accelerators. Your existing 2D games and applications will snap to life with 128-bit acceleration and faster, more vibrant colors.



You can use the ALL-IN-WONDER 128 family of cards to connect your computer to a television. This feature is ideal for playing games, giving presentations, watching movies, and browsing the Internet. (For more information, see [Attaching a TV to Your Card](#) on page 28.)

The ALL-IN-WONDER 128 family also turns your PC into an intelligent TV with the following features:

- Zoom-in
- Scheduled Viewing
- Channel Scanning
- Video capture
- Closed Captioning with “Hot Words” and “Look Back” features
- Program transcript recording
- TV magazine
- Instant Replay
- Digital VCR with real-time video compression
- dbx[®] stereo audio TV (Because Europe uses different stereo TV standards, only the 32MB version of ALL-IN-WONDER 128 provides stereo TV audio in Europe.)

System Requirements

Computer system	Pentium [®] /Pentium [®] Pro [®] , Pentium [®] , II Pentium [®] III, Celeron [™] or compatible systems with PCI Local Bus or AGP bus (ALL-IN-WONDER 128 PRO is AGP-only).
Expansion Slot	<ul style="list-style-type: none">• 32-bit PCI slot.• AGP 4X / 2X (backward-compatible to support AGP 2X; AGP 4X motherboard required to enable AGP 4X).
Operating System	Windows [®] 95b (OSR2), Windows [®] 98, or Windows [®] 98 SE.
Monitor	VGA, supporting minimum 640x480 resolution. <i>A Plug-and-Play monitor that supports VESA's Display Channel specifications (DDC1 or DDC2b) is required to take advantage of the DDC1/DDC2b features.</i>

Other Sources of Information

If you need additional help or require information that is not included in this guide, see the following sources:

Readme File



This file contains the latest information about your ALL-IN-WONDER 128 or ALL-IN-WONDER 128 PRO card.

To view the Readme file in DOS

- 1** Insert the *ATI Installation CD-ROM* into your CD-ROM drive.
- 2** In an MS-DOS window, type **D:** (or substitute your CD-ROM drive letter).
- 3** Type **README**.

Online Help



If you require additional information, you can refer to the online help available under Windows[®] 95 or Windows[®] 98 for more information about using ATI's enhanced drivers.



For information on your card's graphics features, double-click the ATI icon in the lower-right corner of your screen.

Online manual



Your ALL-IN-WONDER 128 or ALL-IN-WONDER 128 PRO comes with an online manual that describes the extensive features of your card.

To open the online manual

- 1** Insert the ATI INSTALLATION CD-ROM into your CD-ROM drive.

If Windows runs the ATI INSTALLATION CD-ROM automatically, proceed to step 5.

- 2** In the Windows[®] 95 / 98 taskbar, click **Start**.
- 3** Click **Run...**
- 4** Type the following: **D:\ATISSETUP**
(or substitute your CD-ROM drive letter.)
- 5** Click the Online Manual icon.

ATI Multimedia Center Guide

The *ATI Multimedia Center User's Guide* that came with your card explains how to use the special features that the ATI Multimedia Center provides.

CHAPTER 2

Installing the Hardware and Software

Installing your card consists of three, easy steps.

- **Placing the card in your computer**
- **Installing ATI's enhanced display drivers**
- **Attaching input and output cables and optional TV, VCR, camcorder, etc.**

This chapter explains how to place the card in your computer, how to install the software, and how to connect the input and output cables.

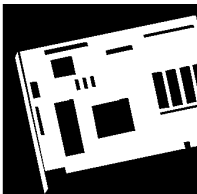

IN THIS CHAPTER...

- **Installing the Hardware** on page 12
- **Installing Enhanced Drivers for Windows® 95 and Windows® 98** on page 18
- **Starting the ATI Multimedia Center in Windows® 95 or Windows® 98** on page 20
- **Input and Output Adapters** on page 21
- **Windows® 95 / Windows® 98 Volume Control** on page 25



Turn off the power to your system, and discharge your body's static electric charge by touching a grounded surface — for example, the metal surface of the power supply — before performing any hardware procedure.

The manufacturer assumes no liability for any damage, caused directly or indirectly, by improper installation of any components by unauthorized service personnel. If you do not feel comfortable performing the installation, consult a qualified computer technician.

Damage to system components, the accelerator card, and injury to yourself may result if power is applied during installation.

Installing the Hardware

Now that you have prepared your computer, you are ready to install your card. If you are not sure whether your card is PCI or AGP, compare the bottom edge of your card with the following illustration:

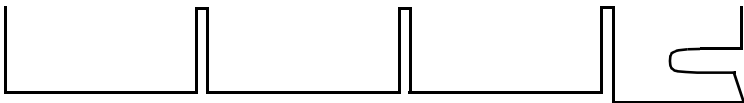

Universal AGP 2x/4x

To install your card

- 1** Power-off the computer and monitor, then disconnect the monitor cable from the back of your computer.

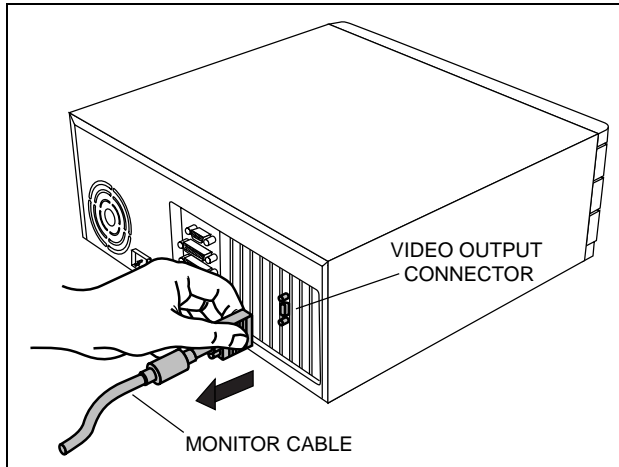

- 2** Remove the computer cover. If necessary, consult your computer system manual about removing the cover.

Remember to discharge your body's static electricity by touching the metal surface of the computer chassis.

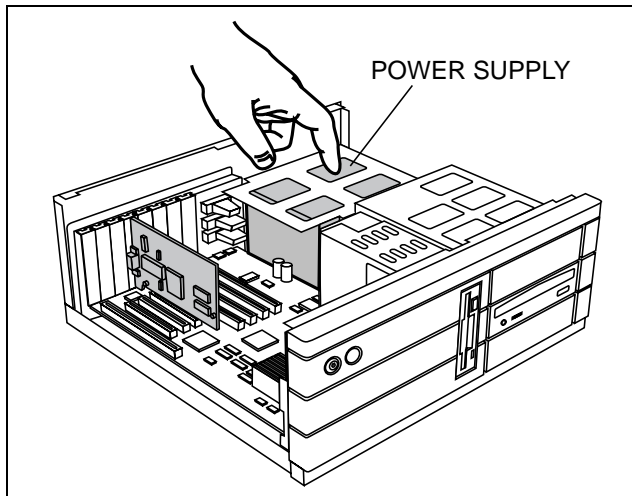

- 3** If you intend to run multiple displays with Windows® 98 (see *Multiple Display Support in Windows® 98* on page 38), proceed to step 4. **Otherwise, remove any existing graphics card** from your computer.

If the old graphics card sticks, rock it gently from end to end. Remember to save the screw.

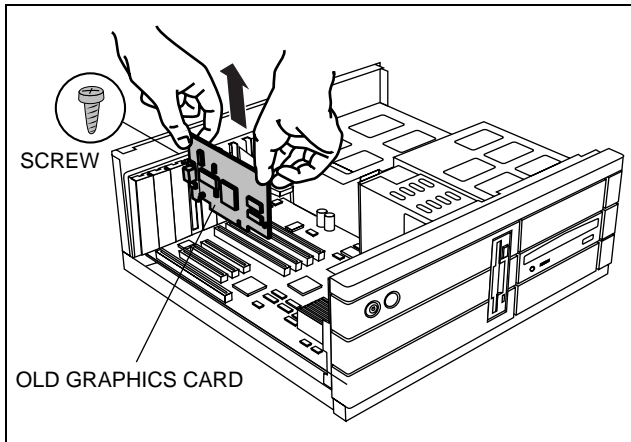

Or, if your computer has any **on-board graphics capability**, you may need to **disable** it on the motherboard. For more information, see your computer documentation.

- 4** If necessary, remove the metal cover from the empty expansion slot that you select (PCI cards use a PCI slot; AGP cards use the AGP slot), then **align your new card with an empty expansion slot, and press it in firmly until fully seated.**

Grasp the new card by the top edge and carefully seat it firmly into the correct slot (PCI or AGP). Ensure that the metal contacts are completely pushed into the slot.

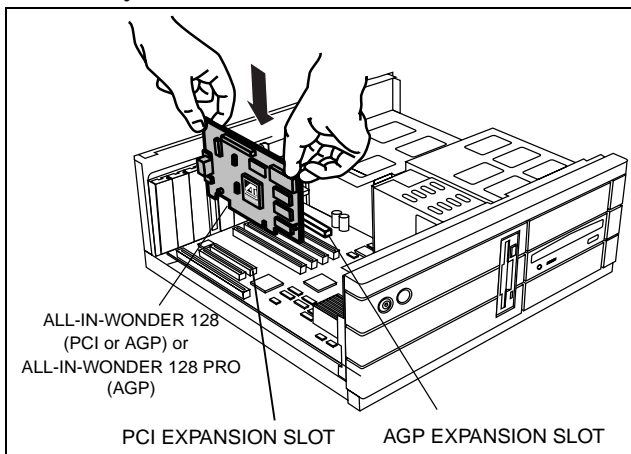

Note: AGP 4x/2x cards can be used in either AGP 4x or AGP 2x slots.

- 5** Replace the screw to fasten the card in place, and replace the computer cover.

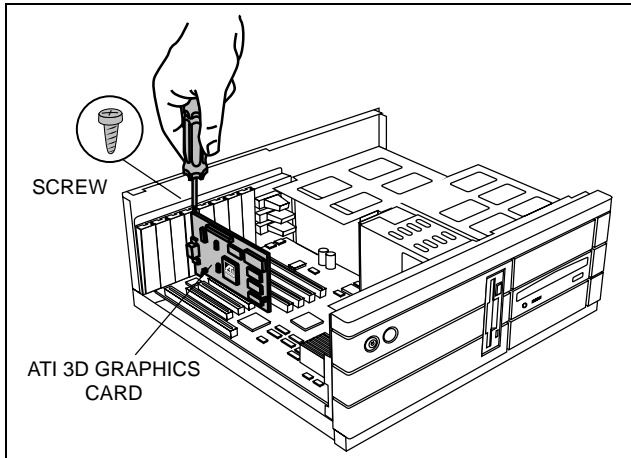

- 6** Plug the monitor cable into your card (if you are running multiple displays under Windows[®] 98, connect their cables to the appropriate connectors), then **turn on the computer and monitor(s)**.

Make sure your monitor cable is securely fastened.

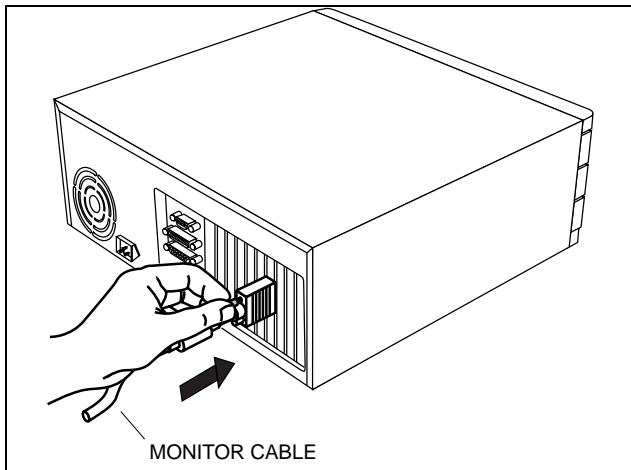

You are now ready to proceed with the installation of ATI's enhanced drivers.

Windows® “New Hardware Found”

If you are running Windows® 95 or Windows® 98, new hardware may be detected after you restart your computer. Follow the step-by-step instructions below to allow Windows® to correctly identify your new hardware.

To identify new hardware in *Windows® 95*

- 1 Windows® 95 briefly displays the “New Hardware Found” dialog before launching the “Update Device Driver Wizard”.

If the wizard does not appear, proceed directly to [Installing Enhanced Drivers for Windows® 95 and Windows® 98](#) on page 18.

- 2 Click **Next**.
- 3 Click **Finish**.
- 4 Insert your Windows® 95 CD-ROM into your CD-ROM drive.
- 5 Click **OK**.
- 6 Type the following:
D:\WIN95
*(If **D** is not your CD-ROM drive, substitute **D** with the correct drive letter.)*
- 7 Click **OK**.
- 8 Click **Yes** to restart your computer.

You are now ready to install your ATI enhanced drivers. Proceed to [Installing Enhanced Drivers for Windows® 95 and Windows® 98](#) on page 18, and follow the step-by-step instructions to complete the installation.

To identify new hardware in *Windows® 98*

After restarting your system, Windows® 98 will briefly display the “New Hardware Found” dialog. Depending on your new hardware, you will either be prompted to insert your Windows® 98 CD-ROM or Windows® 98 will launch the “Add New Hardware Wizard”.

If Windows[®] 98 automatically begins installing drivers for your new hardware, click **Yes** to restart your computer when prompted; then proceed to *Installing Enhanced Drivers for Windows[®] 95 and Windows[®] 98* on page 18.

To identify new hardware using *Windows[®] 98 CD-ROM*

- 1 Insert your Windows[®] 98 CD-ROM.
- 2 Click **OK**.
- 3 Type the following:
D:\WIN98
*(If **D** is not your CD-ROM drive, substitute **D** with the correct drive letter.)*
- 4 Click **OK**.
- 5 Click **Yes** to restart your computer.

You are now ready to install your ATI enhanced drivers. Proceed to *Installing Enhanced Drivers for Windows[®] 95 and Windows[®] 98* on page 18, and follow the step-by-step instructions to complete the installation.

To identify new hardware using “*Add New Hardware Wizard*”

- 1 Windows[®] 98 launches the “Add New Hardware Wizard”, which prompts you to search for the Standard PCI Graphics Adapter (VGA).
- 2 Click **Next** to continue.
- 3 Select **Search for the best driver for your device**.
- 4 Click **Next** to continue.
- 5 Click **Next** to start the driver search.
- 6 Click **Next** to install the Standard PCI Graphics Adapter (VGA).
- 7 Click **Finish**.
- 8 Click **Yes** to restart your computer.

You are now ready to install your ATI enhanced drivers. Proceed to *Installing Enhanced Drivers for Windows[®] 95 and Windows[®] 98* on page 18, and follow the step-by-step instructions to complete the installation.

Installing Enhanced Drivers for Windows[®] 95 and Windows[®] 98

With Windows[®] 95 or Windows[®] 98 running on your computer, you need to install the enhanced ATI drivers to take advantage of your card's higher performance, resolutions, and special features. To ensure that you install the latest drivers, install the ATI enhanced drivers located on the CD-ROM shipped with your graphics accelerator card.

Notes

- **Close all open applications** before installing your ATI software.
- Before installing the ATI enhanced drivers, ensure that any previously-installed ATI display drivers have been **removed** from your system. To do this:
 1. In **My Computer**, double-click **Control Panel**, then double-click **Add/Remove Programs**.
 2. Click **ATI Display Driver**, then click **Add/Remove**.
- Always use the **latest version** of the ATI Installation CD-ROM to install ATI display drivers and multimedia software. The last three digits of the CD part number represent the version — a higher number indicates a later version.
- All ATI Installation CD-ROMs include a complete set of display drivers and multimedia software.

To install the ATI enhanced drivers for Windows[®] 95 or Windows[®] 98

- 1 Insert the ATI INSTALLATION CD-ROM into your CD-ROM drive.
If Windows[®] runs the CD-ROM automatically, proceed to step 6.
- 2 Click **Start**.
- 3 Select **Run**.
- 4 Type the following:
D:\ATISSETUP
*(If **D** is not your CD-ROM drive, substitute **D** with the correct drive letter.)*

- 5 Click **OK**.
- 6 Click **ATI Easy Install** to begin the Installation Wizard.
- 7 Click **Next**.
- 8 Click **Yes** to accept the license agreement.
- 9 Follow the Wizard's on-screen instructions to complete the installation.

*The **Express** installation option is recommended. If your ATI product includes a **multimedia** component, the software for that component will **automatically** be installed, along with the ATI enhanced drivers, by selecting this option.*

- 10 When the **Select DVD Region** screen appears, choose the applicable region, then click **Next**.
- 11 When the **Setup Complete** screen appears, click **Yes** to restart your computer, remove the ATI INSTALLATION CD-ROM, then click **Finish**.

The first time you restart your computer, more drivers will automatically be installed.



*For correct resolution and refresh rate operation, you need to select a **display device**. You should also change the **color palette** from 256 colors (the default) to a higher number of colors. ATI recommends at least "High Color (16-bit)" for best performance with its multimedia applications.*

To increase the number of colors

- 1 Right-click on a clear area of your desktop, then click **Properties**.
- 2 Click **Settings**.

*If you are using multiple monitors, click the monitor icon whose color depth you want to change. If you click a secondary monitor and **Extend my Windows desktop onto this monitor** is not checked, you cannot change that monitor's settings.*

Each monitor has its own color settings.

- 3 In the **Colors** box, select **High Color (16 bit)**, **True Color (24 bit)** or **True Color (32 bit)**.

Your type of monitor and video adapter determine the maximum number of colors.



The RAGE 128 display drivers on your ATI Installation CD-ROM are the latest and fastest available, but at ATI, we are constantly improving our products, so check the ATI web site at <http://www.atitech.ca> for newer software.

- 1 Click **North America** or **Europe**.
- 2 Click **Drivers / Updates**, then click **Retail Generic - Supported**.



Drivers downloaded from the ATI website:

- Double-click the self-extracting executable file to start the installation.

Note

Windows will automatically reboot your system after the drivers are installed.

Starting the ATI Multimedia Center in Windows[®] 95 or Windows[®] 98



From LaunchPad. The LaunchPad provides a convenient way to start all your Multimedia Center features—just click the one you want. LaunchPad opens automatically when you start your computer, or if you prefer, you can right-click LaunchPad, and uncheck **Load on Startup** in the drop-down menu to disable this feature.

From Windows[®] taskbar.

- 1 In the Windows taskbar, click **Start**.
- 2 Point at **Programs** ►.
- 3 Point at **ATI Multimedia** ►.
- 4 Click **TV, Video Editor, CD Audio, DVD, or Video-CD**.

For information on the ATI Multimedia Center, see the online help.

Input and Output Adapters

Your ALL-IN-WONDER 128 or ALL-IN-WONDER 128 PRO card uses input and output adapters that let you connect audio and video devices to the card. You can use these adapters to:

- Connect a VCR, laserdisc player, or camcorder, and watch movies on your PC.
- Connect your camcorder and capture video for use in presentations, Web pages, or use third-party videoconferencing software.
- Connect your big-screen TV, and share the PC experience with a group of people, or play games on your big-screen TV.
- Attach a VCR to the video output and record presentations, games, internet, etc.

Notes

- To hear sound when you use your ALL-IN-WONDER 128 family card's TV feature, ensure that your card is connected to the **line-in** connector of your sound card: see [page 24](#).
- For information on the CD audio connectors see [page 48](#)

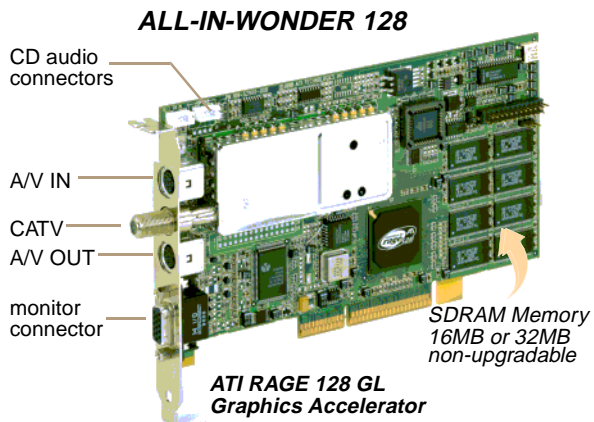

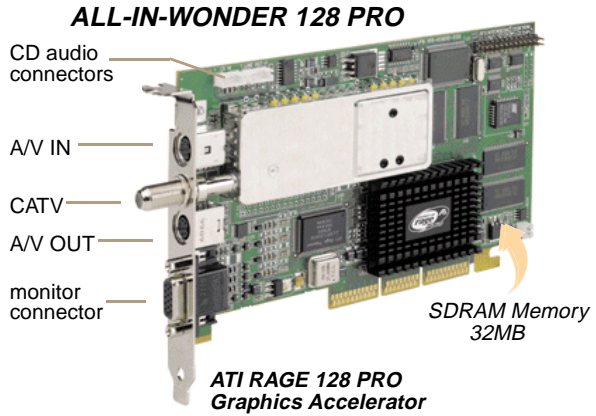

Notes

Macrovision Please note that the ALL-IN-WONDER 128 and ALL-IN-WONDER 128 PRO detect Macrovision on an input video source, and will refuse to capture video from such a source. Many VHS tapes and DVD discs are protected with Macrovision, which protects them from being copied onto your computer using the ALL-IN-WONDER 128 or ALL-IN-WONDER 128 PRO.

DVD audio output The ALL-IN-WONDER 128 family of cards supports Dolby ProLogic™ output for connection to a surround-sound system through the standard stereo output connection from your sound card. The ALL-IN-WONDER family does not support S/PDIF digital audio output at this time.

To watch movies on your PC or capture video from your VCR, camcorder, or laserdisc player

Use the ATI input adapter to connect a VCR, camcorder, or laserdisc player to your ALL-IN-WONDER 128 or ALL-IN-WONDER 128 PRO, as shown.



The audio and video **output** connectors on your VCR, camcorder, or laserdisc player will be similar to these. Use composite video out **or** s-video out. S-Video will provide better results.

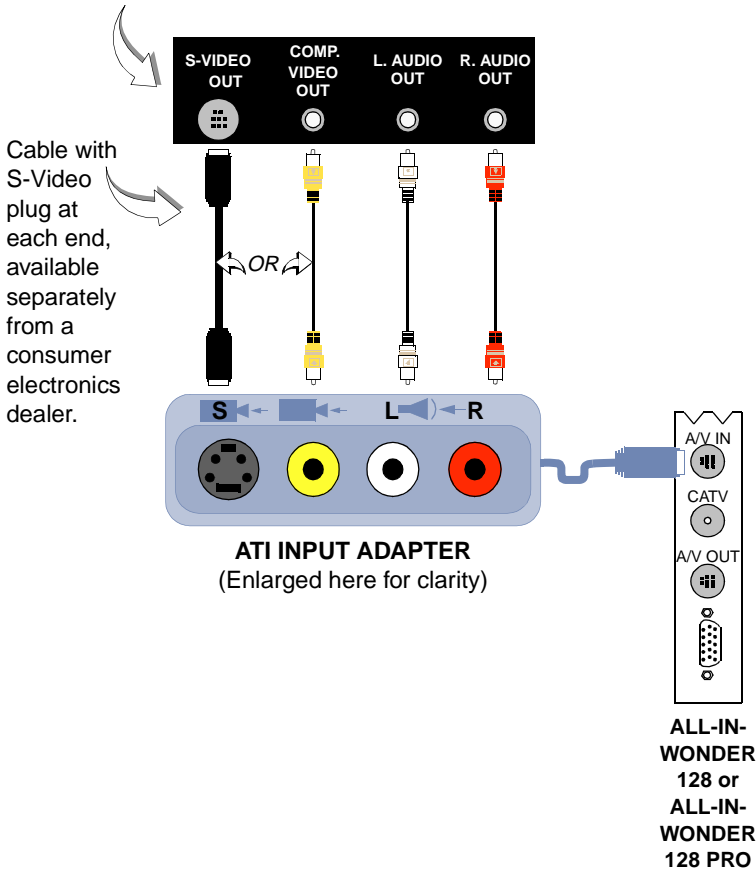

To display your PC output on TV and record your PC output on videotape

Use the output adapter to connect a TV, camcorder, or VCR to your ALL-IN-WONDER 128 or ALL-IN-WONDER 128 PRO, as shown.



The audio and video **input** connectors on your TV, camcorder, or VCR will be similar to these. Use COMPOSITE VIDEO IN or S-VIDEO IN. S-Video will provide better results.

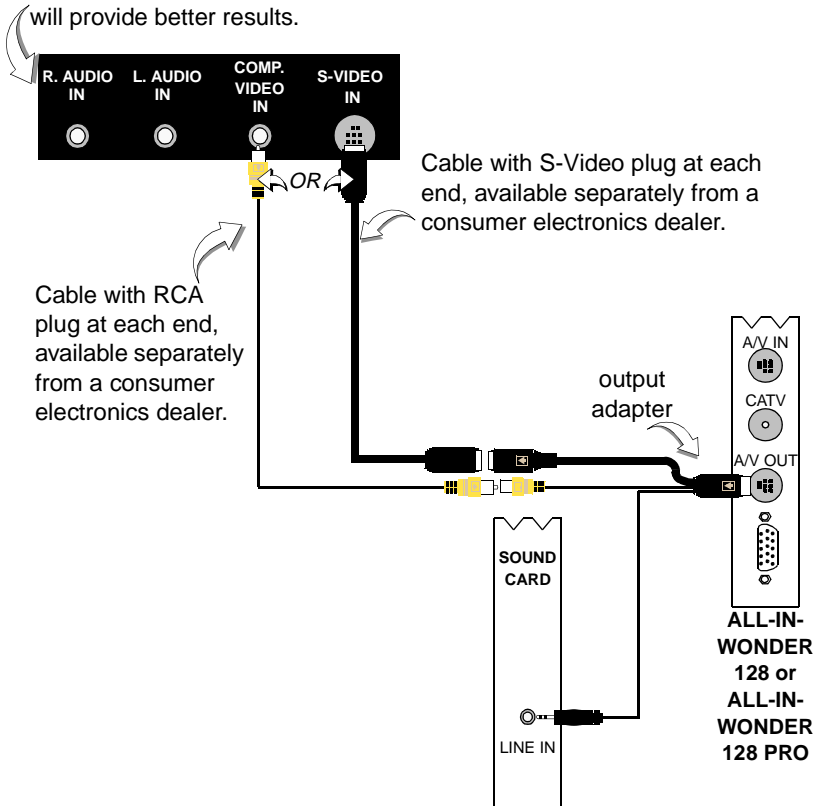

Windows[®] 95 / Windows[®] 98 Volume Control

For correct audio performance, your sound card's line input must be active. To display the Line Input setting in the Windows 95[®] / Windows[®] 98 Volume Control panel:

- 1** Right-click the speaker icon  in the Taskbar (usually in the lower-right corner of your screen).
- 2** Click **Open Volume Controls**.
- 3** If the Line-In volume slider is not visible, click **Options**, then click **Properties**.
- 4** Click the **Line-In** volume control checkbox, then click **OK**.
 - If the **Mute** checkbox is checked, click it to cancel muting.

If the speaker icon is not in your Taskbar, do the following:

- In the Windows taskbar, click **Start**, point to **Settings**, then click **Control Panel**.
- Double-click **Multimedia**.
- In the **Audio** tab, check **Show volume control on Taskbar**.

To select the sound card connector for TV audio input

The sound card connector determines which mixer slider is controlled by the ATI Multimedia Center's volume slider.

- 1**  Click the Setup button in the TV Player control panel, then click the **Display** tab.
- 2** Click the **Initialization** button, then click the **Next** button three times to open the TV Sound Initialization Wizard.
- 3** Click the audio input that matches the connection between your ATI card and your sound card. If you are not sure how it is connected, click each source (CD Audio, Line-In, etc.), and listen for the sound.

TV reception tips



- In the TV Tuner tab, ensure that you click the **correct setting for cable or antenna**.
- For the best indoor antenna reception, use an **amplified** model, and move it as **far away from your monitor** as possible.
- If you experience problems with cable input, a signal amplifier may improve reception.

CHAPTER 3

Using Your ALL-IN-WONDER 128 or ALL-IN-WONDER 128 PRO

For comprehensive information on your card's multimedia features, please see the *Using Your ATI Multimedia Center* User's Guide that came with your card.



IN THIS CHAPTER...

- **Attaching a TV to Your Card** on page 28
- **Using TV Out** on page 29
- **Connecting your PC to a television or a VCR** on page 30
- **Using SCART connectors for European televisions** on page 32

Attaching a TV to Your Card

Using your ALL-IN-WONDER 128 family card, you can connect a television set as your computer's display. You can use your card to do the following:

- View computer output directly on your television in either NTSC or PAL formats (depending upon the country where you purchased your card)
- Connect using Composite or S-Video output capabilities
- Display images on both the TV and PC monitor simultaneously
- Provide a big-screen experience for entertainment PCs that is ideal for playing games, giving presentations, watching movies, and browsing the Internet

To connect your graphics card to a television

- 1 Turn off your computer and your television.
- 2 Determine if your television has an S-Video connection or an RCA video-in connection.
- 3 Looking at the back of your computer, locate your graphics card (see diagram below).

Card Connectors

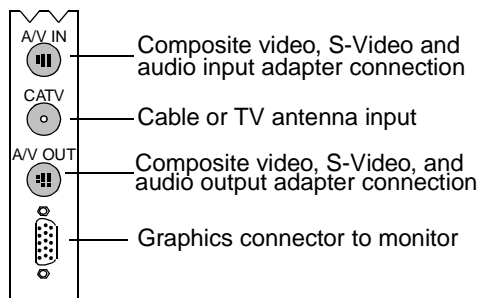

- 4 Connect the supplied output cable adapter to the A/V OUT connector on the card.
- 5 Using a cable with either S-Video or RCA connectors, attach one end of the cable to the output cable adapter and the other to your television.

- 6 Turn on your computer and your television.

If there is no display, you may need to enable the television output capability; see Using TV Out.

For detailed cabling diagrams and audio connections, see Input and Output Adapters on page 21.

Note You must attach a TV before enabling TV output.

Using TV Out

Television display is ideal for playing games, giving presentations, watching movies, and browsing the Internet. The following tips will help you get the most out of your TV Out feature.



IMPORTANT INFORMATION for European Customers

Some PC monitors in Europe **cannot** be used simultaneously with television display. When you enable television display in Europe, the refresh rate for the monitor and television is set to 50Hz. Some monitors may not support this refresh rate and could be damaged.

- Please check the documentation supplied with your monitor to see if your monitor supports a refresh rate of 50Hz.

If your monitor does not support 50 Hz (or if you are not sure), then turn off your monitor before turning on your computer when using your television as a display.

For information on disabling television display, see [To enable and disable the television display on page 32](#).

Some televisions in Europe may use an SCART connection. If you use SCART, please read [Using SCART connectors for European televisions on page 32](#) before attempting to connect your PC to your television.

Connecting your PC to a television or a VCR

To connect your computer to a television or a VCR, attach a connector cable from the television (or VCR) to your card. Most televisions and VCRs have a Composite video input, also referred to as a phono jack or RCA input. A growing number of televisions and VCRs have another type of video input called S-Video or S-VHS. An S-Video connection produces a higher quality display than Composite video.

If your television has cable input only, which is the case on older units, you can connect your graphics card to your television using your VCR or an RF modulator (available in most electronics stores).

To connect your TV Out graphics card to a television or VCR

- 1 Turn off your computer and your television or VCR.
- 2 Ensure your graphics card is installed correctly.

*To use television display, you need the enhanced ATI driver (version 6.00 or greater) installed on your system. For information about placing the card in your computer and installing the enhanced ATI driver, see the **Getting Started...** chapter.*

- 3 Determine if your television or VCR has an S-Video or Composite video connection.
- 4 Looking at the back of your computer, locate your graphics card. Using an S-Video or Composite cable, attach one end of the cable to your graphics card and the other to your television or VCR. (See the illustration, *Connecting your ATI graphics card to a TV or VCR on page 31.*)
- 5 Turn on your computer and your television or VCR.
- 6 To turn your television display on and off, please see *To enable and disable the television display* on page 32.

If there is no display on your television, you may need to switch your television to video display. For more information, see the documentation supplied with your television.

If you have a television connected to your VCR, you can use the television as your computer's display. For information about connecting a television to your VCR, see the documentation that came with your VCR.

The audio and video **input** connectors on your TV or VCR will be similar to these. Use composite video in **or** s-video in. S-Video will provide better results.

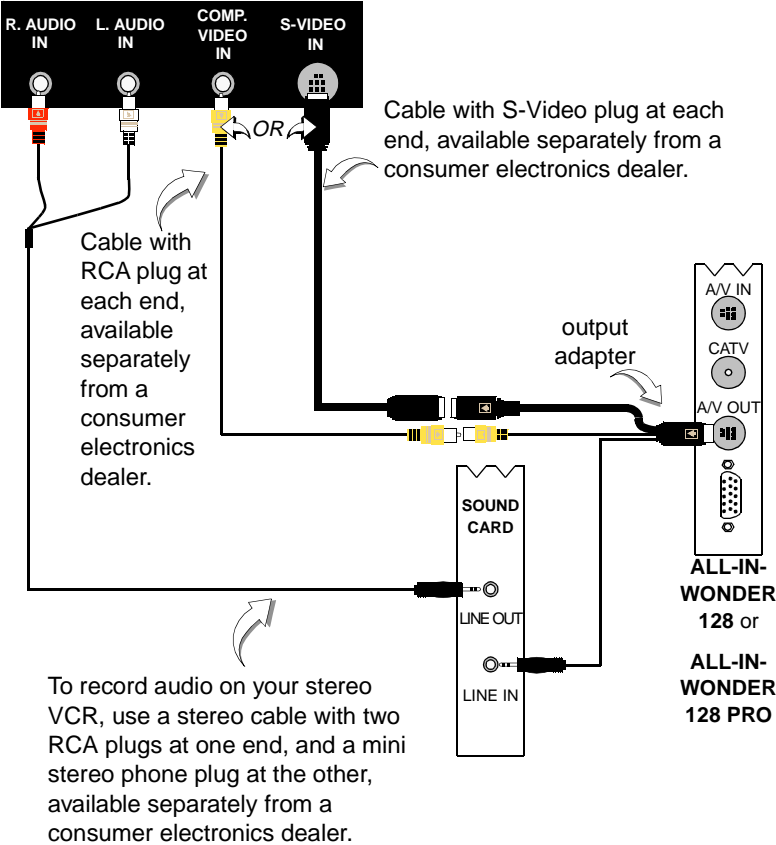

Connecting your ATI graphics card to a TV or VCR

Using SCART connectors for European televisions

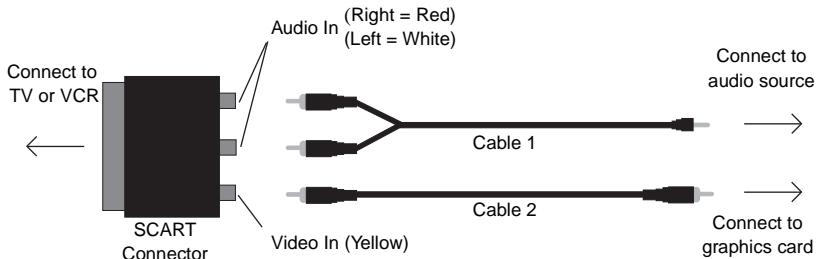

Using an SCART connector with a Composite cable

The SCART connector supports only the Composite video format, which is the most common type. The above illustration shows how to connect to an SCART connector with a Composite cable.

If your television supports S-Video (also called S-VHS) video input, you should use an S-Video cable (available in most consumer electronics stores) to view your PC on a television. An S-Video connection produces a higher quality display than Composite video.

Using and Adjusting TV Out

To enable and disable the television display

- 1 Start Windows[®].
- 2 Click **Start**.
- 3 Point to **Settings**, then click **Control Panel**.
- 4 Double-click **Display**.
- 5 Click the **ATI Displays** tab.
*Windows[®] 98 users click the **Advanced...** button, then click the **ATI Displays** tab.*
- 6 Click the green **enable/disable** button next to the word "TV" to enable/disable television display.
- 7 Click **OK** or **Apply** to save the changes you have made.
*For information about how to use television display and the **ATI Displays Properties** page, click the **Help** button.*

Starting Windows® with Television Display Enabled

The television screen may become scrambled temporarily during the initial Windows® logo display. This is only a temporary effect, and your television screen will be restored within a few seconds.

During start up, your TV Out graphics card will go through a sequence of mode settings, during which your television display will remain blank. This process takes only a few seconds and helps program the television display.

Using a Monitor vs. Using the Television Display

Using your television for your computer's display is ideal for playing games, giving presentations, watching movies, and browsing the Internet. The display on your monitor may change or look squashed. This occurs because the display adjusts to fit the dimensions of your television. To correct the monitor's display, use the controls on the monitor to adjust the display size and position.

Some single-frequency monitors may not work with television display enabled. If you experience problems when television display is enabled, disable television display to restore your monitor's display.

Adjusting the Monitor Display

The size of the display on your monitor may be smaller and not perfectly centered when you have television display enabled. These effects are caused by the changes required to provide a proper display on the television.

Use the controls available on the Adjustments tab on the Monitor Properties page (click the **Monitor** button on the ATI Displays page) to adjust the display on your monitor only. Click the **Television** button to adjust the television display only.

Viewing Text on Television

Due to the different technology used in the manufacturing of televisions and PC monitors, standard PC text may look too small on your television. You can compensate for this by using larger fonts.

To Use Larger Display Fonts

- 1** Start Windows®.
- 2** Click **Start**.
- 3** Point to **Settings**, then click **Control Panel**.
- 4** Double-click **Display**.
- 5** Click the **Settings** tab.
- 6** In the **Font Size** box, select the size you want your displayed fonts to be.
*Windows® 98 users click the **Advanced...** button then select your font size.*
- 7** To customize the size of displayed fonts, select **Custom** or **Other**.
- 8** Click the **OK** button, then click the **Close** button. Click the **Yes** button to restart your computer and use your new settings.

Reducing Edge Distortion

When using a television for your PC's display, you may see some edge distortion on the left and right side of your television screen. This effect depends on your television and the PC application you are running. To reduce edge distortion, you can increase the horizontal size.

To Increase the Horizontal Size

- 1 Start Windows®.
- 2 Click **Start**.
- 3 Point to **Settings**, then click **Control Panel**.
- 4 Double-click **Display**.
- 5 Click the **ATI Displays** tab.
*Windows® 98 users click the **Advanced...** button, then click the **ATI Displays** tab.*
- 6 Click the **TV** button.
- 7 Click the **Adjustments** tab.
- 8 Click the plus (+) button under Horizontal Screen to increase the horizontal size of the television display.
- 9 Click **OK** or **Apply** to save the changes you have made.

You can also reduce edge distortion by reducing the brightness.

To change the brightness

- 1 Start Windows®.
- 2 Click **Start**.
- 3 Point to **Settings**, then click **Control Panel**.
- 4 Double-click **Display**.
- 5 Click the **ATI Displays** tab.
*Windows® 98 users click the **Advanced...** button, then click the **ATI Displays** tab.*
- 6 Click the **TV** button.
- 7 Drag the **Brightness slider** to the left to decrease the brightness.
- 8 Click **OK** or **Apply** to save the changes you have made.

Changing Display Configurations

If you move your computer to a place where you are using television display only, make sure that you have the television display feature enabled first; see *To enable and disable the television display* on page 32.

Using Games and Applications

Some older games and applications may program the graphics card directly to run under a specific display mode. This may cause your television display to turn off automatically or become scrambled (the PC monitor will not be affected). Your television display will be restored once you exit the game or if you restart your system.

CHAPTER 4

For Windows® 98 Users...

Windows® 98 offers many exciting new features for users with an ALL-IN-WONDER 128 or ALL-IN-WONDER 128 PRO.



IN THIS CHAPTER...

- **Multiple Display Support in Windows® 98** on page 38
- **WebTV® for Windows** on page 39
- **NetMeeting™ 2.1** on page 40

Multiple Display Support in Windows® 98



Windows® 98 provides support for using more than one display device at a time—you simply install a separate PCI or AGP card for each additional monitor you intend to use. With multiple displays, you can expand your desktop, run different programs on separate displays, even play some newer games with multiple views. Each display can have a different resolution and color depth!

You can use multiple monitors **and** a single television at the same time.

Windows® 98 automatically designates one graphics card as the **primary** graphics card. Each additional graphics card is designated as a **secondary** card. Certain 3D and multimedia features are only available on the **primary** graphics card. If you are installing more than one graphics card, you need to consider the following:

- If you install both a **PCI and an AGP** graphics card in the same system, the **AGP** graphics card will become the **secondary** graphics card.
- If you install **two or more PCI** graphics cards in the same system, the primary graphics card is typically the one installed in the PCI slot with the *lowest* number—this is typically the PCI slot farthest from the computer's ISA slots. Consult your computer system manual for help in selecting a slot.

The latest information on installing ATI's cards and enhanced drivers for Windows® 98 is provided in the Readme file on the ATI Installation CD-ROM.

NOTE

Some motherboards will allow an **AGP** card to act as the **primary** graphics card. A motherboard flash BIOS (for example, ASUS, Intel) may be required to enable this feature. Check your motherboard manufacturer's website for information.

WebTV® for Windows

*North
American
feature*

The ALL-IN-WONDER 128 family's advanced TV Tuner capabilities are a perfect match for Windows® 98's new WebTV interface. Use your Internet connection to instantly download television program information for current and future shows.

If you do not have an Internet connection, you can download the same program information over a cable connection! WebTV puts you in control of your TV scheduling, and allows you to navigate interactive programming — never miss your favorite show!

NOTE

To enjoy WebTV on your ALL-IN-WONDER 128 family-equipped PC, you must use the **ATI 6.00 or later display drivers**.

Windows will automatically reboot your system after the drivers are installed.

To install WebTV on your Windows® 98 system

- 1** In the Windows taskbar, click **Start**.
- 2** Point at **Settings ►**, and click **Control Panel**.
- 3** Double-click the **Add/Remove Programs** icon.
- 4** Click the **Windows Setup** tab.
- 5** Double-click the **Web TV for Windows** item.
Ensure that both WaveTop Data Broadcasting and WebTV for Windows are checked.
- 6** Click **OK**, and allow Windows® 98 to install the new components.

You will want to use the ATI Multimedia Center for advanced features such as Instant Replay and video capture, and WebTV to access interactive program guides and interactive web content.

NOTE

WebTV and the ATI Multimedia Center cannot be used at the same time; you must close one before running the other.

NetMeeting™ 2.1

Windows® 98's NetMeeting 2.1 provides a single interface for multipoint data conferencing and collaboration on virtually any Windows-based application, in addition to high quality videoconferencing over a LAN or the Internet. All you need is a video camera that supports composite or S-Video out: plug it into your ALL-IN-WONDER 128 family card's video input port, and you'll be ready to use your computer as an Internet video-phone!

To set up Microsoft NetMeeting on your computer

- 1 In the Windows taskbar, click **Start**.
- 2 Point at **Programs ►**, then point at **Internet Explorer ►**, and click **Microsoft NetMeeting**.

The NetMeeting install wizard will guide you through several simple steps, and ask you which capture driver you would like to use. Select the driver labeled

VfW MM 16-bit WDM capture driver.

NOTE

You must use the Windows 98 or RAGE 128 display drivers with Net-Meeting.

CHAPTER 5

Tips and Tricks

This chapter suggests some exciting new ways to use your ALL-IN-WONDER 128 or ALL-IN-WONDER 128 PRO. You will need to attach a video camera to your card, following the instructions on page 23.

Many camcorders and digital cameras have composite or S-Video outputs that will provide real-time images on your card. Using the ATI Multimedia Center's Digital VCR feature, you can capture them as still frames and full-motion clips.



IN THIS CHAPTER...

- **Video Email** on page 42
- **Stop-Motion Animation** on page 42
- **Security Camera** on page 43

Video Email

Use your ALL-IN-WONDER 128 or ALL-IN-WONDER 128 PRO to capture a video clip, which you then attach to an email message for your family and friends.

Because video files can be very large, you should use a small capture size – 240x160 or smaller – and the card’s video compression features to reduce the file size (see *Capturing video and still images* in the *Using Your ATI Multimedia Center User’s Guide*).

- **Indeo 3.2** or **4.1** are popular compression codecs (encoder-decoders) that can dramatically reduce the file size while maintaining good quality. Any Windows 95 / Windows 98 system will play Indeo 3.2.
- If you use the **ATI VCR 1.0** or **2.0** codec to compress your video on-the-fly, you must ensure that the receiving computer can play these files back.
- MPEG-1 is also a standard format, which most Windows® and Macintosh® computers can play.

Macrovision

Note

Please note that the ALL-IN-WONDER 128 and ALL-IN-WONDER 128 PRO detect Macrovision on an input video source, and will refuse to capture video from such a source. Many VHS tapes and DVD discs are protected with Macrovision, which protects them from being copied onto your computer using the ALL-IN-WONDER 128 or ALL-IN-WONDER 128 PRO.

Stop-Motion Animation

Using the TV Player’s **sequence capture** feature, you can take a series of still shots and save them as an .AVI movie. You can use this feature to easily produce a “claymation” or other work-in-progress type of movie. See *To record a sequence of frames (stop-motion)* in the *Using Your Multimedia Center User’s Guide*.

Security Camera

Your ALL-IN-WONDER 128 or ALL-IN-WONDER 128 PRO provides an ideal way to capture video for an extremely long period of time—no more worries about your security camera running out of tape! Simply set your card to a lower video capture frame rate, and capture many high quality still images automatically, for days at a time. See *Capturing video and still images* and *Digital VCR settings* in the *ATI Multimedia Center User's Guide*.

suggested settings

Codec	ATI VCR 2.0
Size	320x240
Frame rate	1 frame per second

Streaming video

An improved security camera would stream the real-time video feed from your card to the internet. Real Networks™ (<http://www.real.com>) provides software to perform this.

CHAPTER 6

Reference

This chapter contains troubleshooting tips and specifications for your ALL-IN-WONDER 128 or ALL-IN-WONDER 128 PRO.



IN THIS CHAPTER...

- **Troubleshooting Tips** on page 46
- **Compliance Information** on page 50

Troubleshooting Tips

The following troubleshooting tips may help you if you experience problems. Contact your dealer for more advanced troubleshooting information.

Basic troubleshooting tips

- Check that the **card is seated properly** in its expansion slot. If the problem still exists, try a different PCI expansion slot.
- Ensure that the **monitor cable is securely fastened** to the card.
- Make sure that the **monitor and computer are plugged in and receiving power**.
- For Windows® 95 / Windows® 98, **disable any built-in graphics capabilities** on your mother board. For more information, see your computer documentation.
- Make sure that you selected the **appropriate monitor** when you installed your enhanced driver.
- If you use an indoor antenna, you will get the best results with an **amplified** model. Place it as **far away from the PC monitor** as possible, to avoid interference.
- Splitting the cable or antenna input can reduce the signal quality. For the best reception, **connect the cable or antenna directly to your card**.
- Make sure that your **audio card's line input is active** (see *Windows® 95 / Windows® 98 Volume Control* on page 25).

Windows[®] 95 / Windows[®] 98 troubleshooting tips

For Windows[®] 95 / Windows[®] 98 troubleshooting tips, right-click the ATI icon in the taskbar, and select **Troubleshooting**.

If you have problems during start-up, start your computer in Safe Mode.

To load Windows[®] 95 / Windows[®] 98 in Safe Mode

- 1** Turn on your computer.
- 2** **In Windows[®] 95**, press the **F8** key when Starting Windows 95 appears on the screen.
In Windows[®] 98, press and hold the **CTRL** key until the Windows 98 Startup Menu appears, then **select the number for Safe Mode**, and press **Enter**.
- 3** Select **Safe Mode**.
 - Disable any programs that launch automatically when you start Windows[®] 95 / Windows[®] 98.
 - Check that you have the correct monitor and display driver selected in the Display Properties. For more information, click Help in the Start menu.
 - Check for the existence of memory managers and ensure they are configured properly.
 - Refer to additional information in the Windows[®] 95 / Windows[®] 98 README file located in the root directory on the ATI Installation CD-ROM.

If you don't hear audio, make sure that your audio card's line input is active (see [Windows[®] 95 / Windows[®] 98 Volume Control on page 25](#)).

CD Audio Connectors

The following illustration shows the CD audio connectors on your ALL-IN-WONDER 128 or ALL-IN-WONDER 128 PRO card.

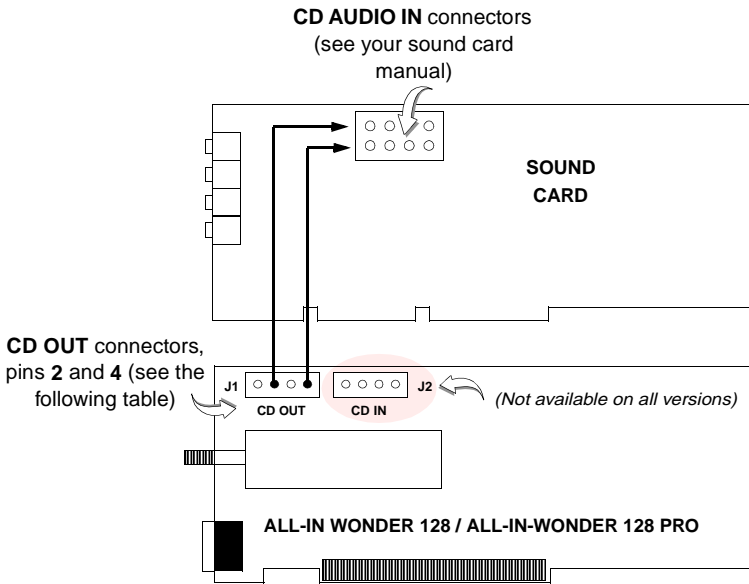

This table lists the pin assignments for the CD audio connectors on your card.

ALL-IN-WONDER 128 FAMILY CARD	SIGNAL	PIN
J2	CD IN	Pin 1 - GND
J2	CD IN	Pin 2 - LEFT IN
J2	CD IN	Pin 3 - GND
J2	CD IN	Pin 4 - RIGHT IN
J1	CD OUT	Pin 1 - GND
J1	CD OUT	Pin 2 - LEFT OUT
J1	CD OUT	Pin 3 - GND
J1	CD OUT	Pin 4 - RIGHT OUT

To Remove the ATI Multimedia Center

- 1** In the Windows taskbar, click **Start**.
- 2** Point to **Settings ▶**.
- 3** Click **Control Panel**.
- 4** Double-click **Add/Remove Programs**.
- 5** Select **ATI Multimedia Center** from the list.
- 6** Click **Add/Remove...**
- 7** Click **OK**.

Japanese Users Please Note ...

- Stereo TV and Secondary Audio Program (SAP) are not available in Japanese versions of the TV Player.

Compliance Information

FCC Compliance Information

The ALL-IN-WONDER 128 family of cards complies with FCC Rules Part 15. Operation is subject to the following two conditions:

- This device may not cause harmful interference, and
- This device must accept any interference received, including interference that may cause undesired operation.

This equipment has been tested and found to comply with the limits for a Class B digital device, pursuant to Part 15 of the FCC Rules. These limits are designed to provide reasonable protection against harmful interference in a residential installation. This equipment generates, uses and can radiate radio frequency energy and, if not installed and used in accordance with manufacturer's instructions, may cause harmful interference to radio communications. However, there is no guarantee that interference will not occur in a particular installation. If this equipment does cause harmful interference to radio or television reception, which can be determined by turning the equipment off and on, the user is encouraged to try to correct the interference by one or more of the following measures:

- Re-orient or relocate the receiving antenna.
- Increase the separation between the equipment and receiver.
- Connect the equipment to an outlet on a circuit different from that to which the receiver is connected.
- Consult the dealer or an experienced radio/TV technician for help.

- The use of shielded cables for connection of the monitor to the graphics card is required to ensure compliance with FCC regulations.
- Changes or modifications to this unit not expressly approved by the party responsible for compliance could void the user's authority to operate this equipment.

Industry Canada Compliance Statement

ICES-003 This Class B digital apparatus meets all requirements of the Canadian Interference-Causing Equipment Regulations.

Cet appareil numérique de la Classe B Respecte toutes les exigences du Règlement sur le matériel brouiller du Canada.

CE Compliance Information

EMC Directive 89/336/EEC and Amendment 92/31/EEC, Class B Digital Device

EN 50081-1, Generic Emissions Standard for Residential, Commercial and Light Industrial Products

(EN 55022/CISPR 22, Limits and Methods of Measurement of Radio Interference Characteristics Information Technology Equipment)

Warning: This is a Class B product. In a domestic environment this product may cause radio interference in which case the user may be required to take adequate measures.

EN 50082-1, Generic Immunity Standard for Residential, Commercial and Light Industrial Products

(IEC 801-2, IEC 801-3, IEC 801-4)

Directive EMC 89/336/CEE et amendement 92/31/CEE, dispositif numérique de Classe B

EN 50081-1, Norme sur les émissions génériques pour les produits domestiques, commerciaux et industriels légers

(EN 55022/CISPR 22, Limites et méthodes de mesure des caractéristiques d'interférences radiophoniques, Matériel des technologies de l'information) *Mise en garde: ceci est un produit de Classe B. Il risque produire des interférences radiophoniques dans un environnement domestique auquel cas l'utilisateur peut se voir demandé de prendre des mesures adéquates.*

EN 50082-1, Norme sur l'immunité générique pour produits domestiques, commerciaux et industriels légers.

(CEI 801-2, CEI 801-3, CEI 801-4)

EMC Richtlinie 89/336/EEC und Änderung 92/31/EEC, Digitale Gerat der Klasse B

EN 50081-1, Allgemeiner Emissions-Standard fur Haushalt- und kommerzielle Produkte sowie Erzeugnisse der Leichtindustrie

(EN 55022/CISPR 22, Beschrankungen und Verfahren der Messung von informationstechnischen Ausrustungen mit Funkstormerkmale)

Warnung: Dies ist ein Erzeugnis der Klasse B. Dieses Erzeugnis kann Funkstorungen im Wohnbereich verursachen; in diesem Fall konnen entsprechende Manahmen seitens des Benutzers erforderlich sein.

EN 50082-1. Allgemeiner Unempfindlichkeits-Standard fur Haushalt- und kommerzielle Produkte sowie Erzeugnisse der Leichtindustrie

(IEC 801-2, IEC 801-3, IEC 801-4)

Index

A

AGP 12

4X, 2X 8

ALL-IN-WONDER family

compliance information 50

ATI Multimedia Center

opening in Windows 95/98 20

uninstalling 49

ATI Multimedia Center User's Guide 10

Audio

DVD audio output 22

recording on your VCR 31

C

Capturing video 23

macrovision 22

CD audio connectors 48

Color depth

increasing 19

Colors

increasing number of 19

Composite video 23

D

Displaying PC output on TV 24

Drivers

downloaded from ATI website 20

DVD

audio output 22

Region Codes 19

I

Input and output adapters 21

displaying PC output on TV and

recording on videotape 24

watching movies on your PC and

capturing video 23

Installing the hardware and software 11

input and output adapters 21

installing the hardware 12

M

Macrovision 22, 42

Monitor

adjusting display 33

using a monitor vs. TV display 33

MPEG-1 42

Multiple display support in Windows 98 38

N

NetMeeting 2.1 40

O

Online Help 9

Online manual 10

P

PCI 12

PCI and AGP graphics cards 38

Primary and secondary graphics cards 38

R

Readme file 9

Recording PC output on videotape 24

Region Codes 19

S

SCART connectors 32

Secondary Audio Program

stereo unavailable in Japan 49

Security camera 43

Sound card connector

selecting for TV audio input 25

Stop-motion animation 42

Streaming video 43

S-Video 23

System requirements 8

T

Tips and Tricks

security camera 43

stop-motion animation 42

streaming video 43

video email 42

Troubleshooting tips 46

basic 46

Windows 95/98 47

TV

attaching to ALL-IN-WONDER

128 28

displaying PC output on 24

reception tips 26

selecting sound card connector for

TV audio input 25

TV Out 29

viewing text on 34

V

Video

composite video, S-Video 30

compressors 42

Video email 42

Volume control 25

W

Watching movies on your PC 23

Watching movies on your PC and capturing video 23

WebTV for Windows 39

Windows 95/98 volume control 25

Windows 98

multiple display support 38

NetMeeting 2.1 40

primary and secondary graphics

cards 38

WebTV 39

Safety instructions for TV tuner products



IMPORTANT SAFETY INSTRUCTIONS

- **Read Instructions** - All the safety and operating instructions should be read before the product is operated.
- **Retain Instructions** - The safety and operating instructions should be retained for future reference.
- **Heed Warnings** - All warnings on the product and the operating instructions should be adhered to.
- **Compatibility** - This option card is for use only with IBM AT or compatible UL Listed personal computers that have Installation Instructions detailing user installation of card cage accessories.
- **Grounding** - CAUTION: For Continued Protection Against Risk of Electric Shock and Fire, This Accessory Should Be Installed Only In Products Equipped With A Three-wire Grounding Plug, A Plug Having a third (Grounding) Pin. This plug will only fit into a grounding-type power outlet. This is a safety feature. If you are unable to insert the plug into the outlet, contact your electrician to replace the obsolete outlet. Do not defeat the safety purpose of the grounding-type plug.
- All option card securement pins shall be completely tightened as to provide continuous bonding between the option card and the PC chassis.
- **Outdoor Antenna Grounding** - Since an outdoor antenna or cable system is connected to the product, be sure that the antenna or cable system is grounded so as to provide some protection against voltage surges and built-up static charges. Article 810 of the National Electrical Code, ANSI/NFPA 70, provides information with regard to proper grounding of the mast and supporting structure, grounding of the lead-in wire to the antenna discharge unit, size of grounding conductors, location of antenna-discharge unit, connection of grounding electrodes, and requirements for the grounding electrode.
- **Lightning** - For added protection for this product during a lightning storm, or when it is left unattended and unused for long periods of time, unplug it from the wall outlet, and disconnect the antenna or cable system. This will prevent damage to the product due to lightning and power-line surges.
- **Power Lines** - An outside antenna system should not be located in the vicinity of overhead power lines or other light or power circuits, or where it can fall into such power lines or circuits.
- When installing an outside antenna system, extreme care should be taken to keep from touching such power lines or circuits, as contact with them may be fatal.
- **Note to CATV System Installer** - This reminder is provided to call the CATV systems installer's attention to Section 820-40 of the NEC, which provides guidelines for proper grounding and, in particular, specifies that the cable ground shall be connected to the grounding system of the building, as close to the point of cable entry as practical.