

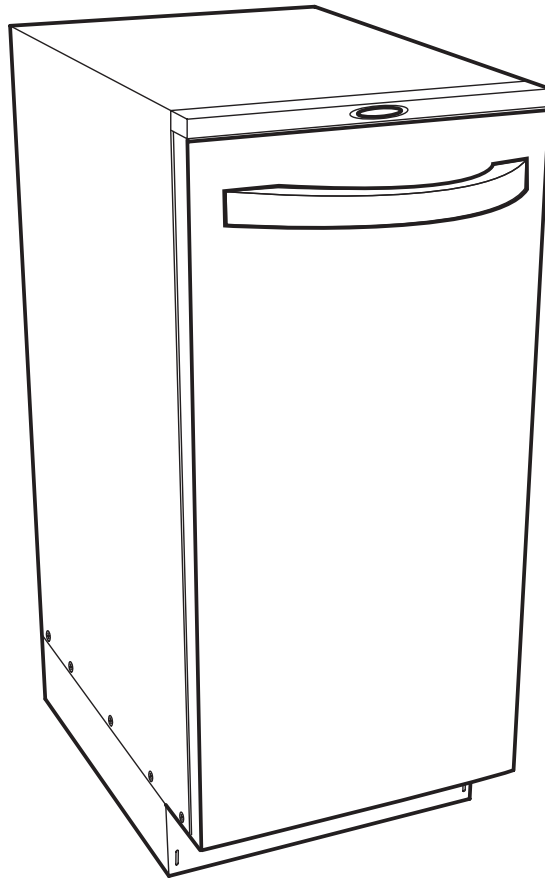

Service Manual

Trash Compactor

Models 15XEWB • 15XEBL • 15XESS • 15XESSA • 15XEWT • 15XETT



99044491A January 2009

Broan-NuTone LLC • 926 West State Street • Hartford, WI 53027 • 1-800-637-1453

Safe Servicing Practices

To avoid personal injury and/or property damage, it is important that Safe Servicing Practices be observed. The following are some limited examples of safe practices.

1. DO NOT attempt a product repair if you have any doubts as to your ability to complete it in a safe and satisfactory manner.
2. Before servicing or moving an appliance, remove the power cord from the electrical outlet, trip the circuit breaker to the OFF position, or remove the fuse.
3. Never interfere with the proper operation of any safety device.
4. USE ONLY REPLACEMENT PARTS CATALOGED FOR THIS APPLIANCE. SUBSTITUTIONS MAY DEFEAT COMPLIANCE WITH SAFETY STANDARDS SET FOR HOME APPLIANCES.
5. GROUNDING: The standard color coding for safety ground wires is GREEN, or GREEN WITH YELLOW STRIPES. Ground leads are not to be used as current-carrying conductors. It is EXTREMELY important that the service technician re-establish all safety grounds prior to completion of service. Failure to do so will create a hazard.
6. Prior to returning the product to service, ensure that:
 - All electrical connections are correct and secure
 - All electrical leads are properly dressed and secured away from sharp edges, high-temperature components, and moving parts
 - All non-insulated electrical terminals, connectors, heaters, etc., are adequately spaced away from all metal parts and panels
 - All safety grounds (both internal and external) are correctly and securely connected
 - All panels are properly and securely re-assembled

NOTE

This service manual is intended for use by persons having electrical and mechanical training and a level of knowledge of these subjects considered acceptable in the appliance repair trade. Broan-NuTone cannot be responsible, or assume any liability, for injury or damage of any kind arising from the use of this manual.

Grounding Instructions

WARNING

FOR PERSONAL SAFETY, THIS APPLIANCE MUST BE PROPERLY GROUNDED.

This power cord on this appliance is equipped with a three-prong (grounding) plug which mates with a standard three-prong (grounded) receptacle.

If there is a two-prong outlet located where you will install the compactor, it is your responsibility to have it replaced with a properly grounded three-prong wall receptacle.

DO NOT, UNDER ANY CIRCUMSTANCES, CUT OR REMOVE THE THIRD (GROUND) PRONG FROM THE POWER CORD.

A 120-volt, 60 Hz., A.C., 15 amp fused and grounded electrical supply is required (time-delay fuse or circuit breaker is recommended). It is recommended that a SEPARATE CIRCUIT serving only this appliance be provided.

DO NOT USE AN EXTENSION CORD WITH THIS APPLIANCE.

Table of contents

| | | | |
|---|----|--|----|
| Safe Servicing Practices | 2 | Section D – Electrical Components | 23 |
| Grounding Instructions | 2 | Start Switch | 24 |
| Features | 4 | Remove and Replace | 24 |
| Section A – Installation | 5 | Access to Components..... | 24 |
| Free-Standing | 5 | Remove Cabinet Cover..... | 24 |
| Built-In Installation | 5 | Re-install Cabinet Cover..... | 26 |
| Mounting Straps..... | 5 | Control Panel Assembly | 27 |
| Under-Counter Opening | 5 | Remove and Re-install | 27 |
| Cord Clamp | 6 | Display Module Assembly..... | 28 |
| Leveling the Compactor..... | 6 | Remove and Re-install | 28 |
| Section B – Cabinet | 7 | Power Supply Board | 28 |
| Trash Bucket | 8 | Remove and Re-install | 28 |
| Remove | 8 | Control Board | 29 |
| Bucket Handle | 8 | Remove and Re-install | 29 |
| Remove and Replace | 8 | Key Switch | 30 |
| Slide Rails (Cabinet)..... | 9 | Remove and Replace | 30 |
| Remove and Re-install | 9 | Interlock Switch Assembly..... | 30 |
| Slide Rails (Bucket) | 9 | Remove and Re-install | 30 |
| Remove and Re-install | 9 | Upper Limit Switch Assembly | 31 |
| Door Assembly | 10 | Remove and Replace | 31 |
| Remove and Re-install | 10 | Lower Limit Switch..... | 31 |
| Reverse Door Hinge Position..... | 11 | Remove and Replace | 31 |
| Safety Interlock Actuator..... | 13 | Motor Centrifugal Switch Assembly..... | 32 |
| Remove and Re-install | 13 | Remove and Replace | 32 |
| Gasket Assembly..... | 14 | Motor Capacitor..... | 32 |
| Remove and Re-install | 14 | Test, Remove and Replace..... | 32 |
| Top Trim Cover Assembly | 15 | Odor Disk Gear Motor | 34 |
| Remove and Re-install | 15 | Remove and Replace | 34 |
| Section C – Power Unit Mechanism | 16 | Power Cable | 35 |
| Drive Belt | 17 | Remove and Replace | 35 |
| Remove and Re-install | 17 | Section E – Troubleshooting | |
| Main Motor..... | 18 | Troubleshooting Table | 36 |
| Remove and Replace | 18 | Section F – Specifications | |
| Complete Power Unit Mechanism..... | 19 | Specifications Table | 39 |
| Remove and Re-install | 19 | Section G – Diagrams and Parts Lists | |
| Drive Wheels | 19 | Wiring Schematic | 40 |
| Remove and Replace | 19 | Drawing and Parts List – Doors | 41 |
| Ram Screw Assembly..... | 20 | Drawing and Parts List – Cabinet | 42 |
| Remove and Replace | 20 | Drawing and Parts List – Mechanism | 43 |

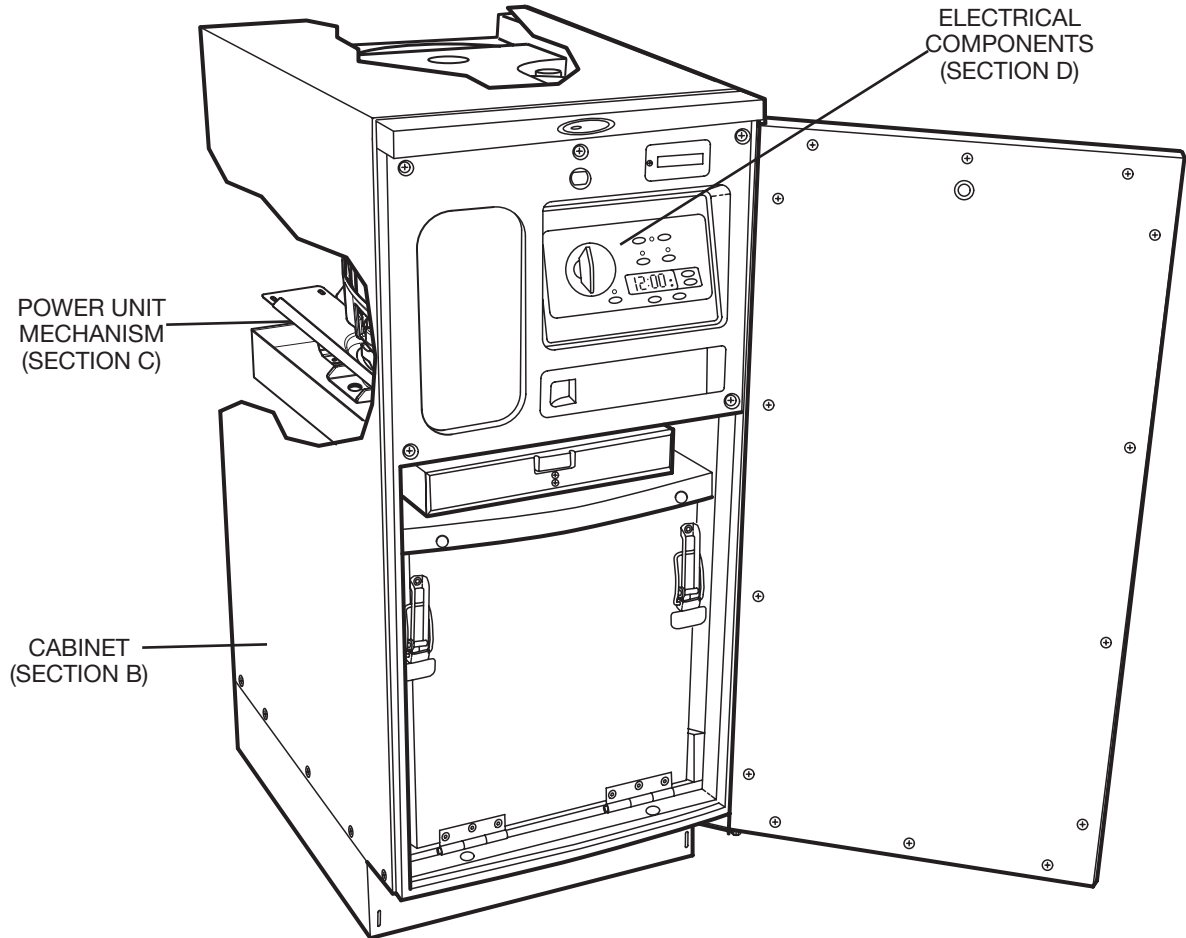

How the compactor works

The compactor compresses household trash up to 1/6 of its original volume. It will compact normal household trash including milk cartons, glass and plastic bottles, containers and jars, tin cans, wrappings, boxes, food wastes, etc.

When you start the compactor, an electrically powered ram moves down into the trash bucket, compresses the trash and then returns to the "UP" position and shuts off automatically.

NOTE: The ram travels about 2/3 of the way down into the trash bucket. Because of this, the trash bucket must be at least 1/3 full before you will notice any compression.

Your compactor has been designed to require minimum space without loss of capacity whether free-standing or built-in.

Free-Standing

As shipped, the compactor is only configured for built-in installations. This appliance can be converted from built-in to free-standing with the use of Toe Kick Accessory Kit Model 15TCTK (sold separately).

If additional cord length is required for free-standing installation, remove the cord clamp and wire tie on the back of the unit.

CAUTION

Failure to use Toe Kick Assembly Kit Model 15TCTK in a free-standing installation may cause the compactor to be unstable during operation.

Built-in Installation

MOUNTING STRAPS

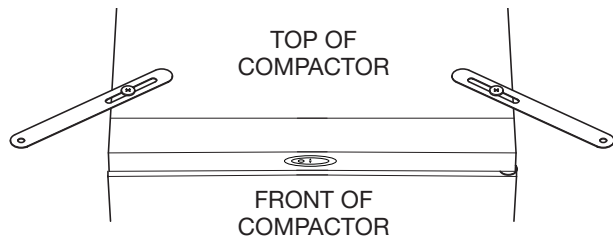

Two under-counter mounting straps are provided. Use these straps to secure the compactor to the underside of a countertop.

Fasten the slotted end of the straps to the compactor using the holes in the top of the compactor cabinet as shown.

NOTE: When installation compactor under granite or solid surface countertops, bend the mounting straps so they can be secured to the adjacent cabinetry.

UNDER-COUNTER OPENING

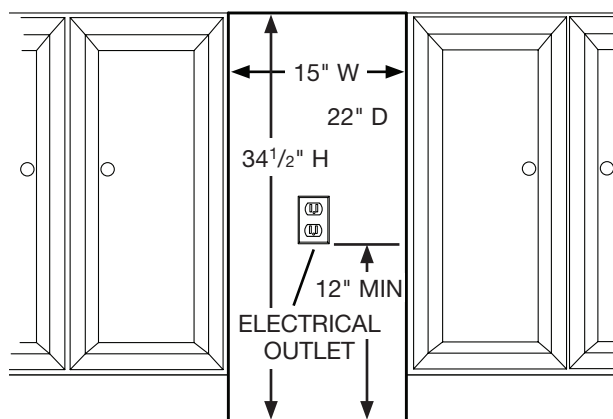

The compactor requires an under-counter opening 15-in. wide, 34-1/2-in. high, and 22-in. deep.

Plan to provide an electrical outlet in the opening that meets all applicable electrical codes and requirements. See "Grounding Instructions" on Page 2 for specific information.

CORD CLAMP

The compactor is equipped with a 6-ft. long power cord. Use the cord clamp to prevent excess power cord from being pinched beneath the cabinet during installation or service.

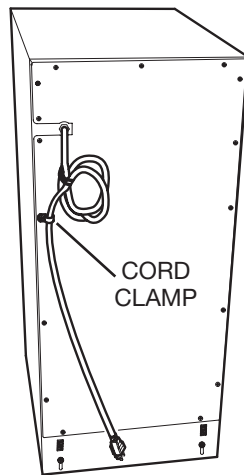

Leveling the Compactor

Your compactor has four adjustable levelers; (2) rollers in the rear and (2) legs in the front. They allow you to adjust for uneven floors and also trim the unit up to fit an under-counter installation.

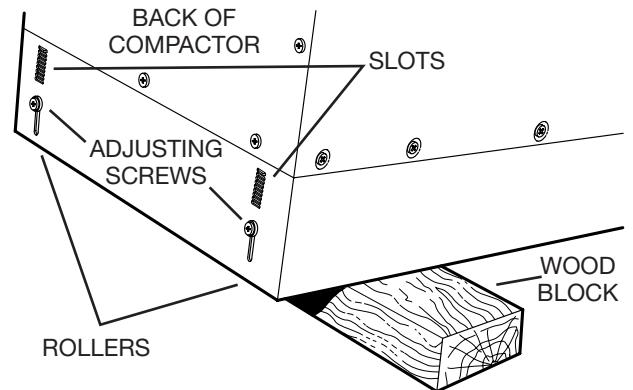

To level the back of the compactor:

Tip the back of compactor up and onto a wood block. Loosen the adjusting screws only far enough to move the rollers to a higher or lower slot. Retighten the adjusting screws and remove the wood block.

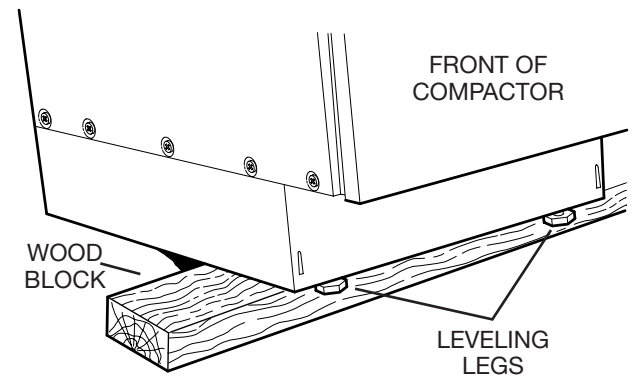

To level the front of the compactor:

Tip the front of compactor up and onto a wood block. Turn the leveling legs in or out to the desired position. Remove the wood block.

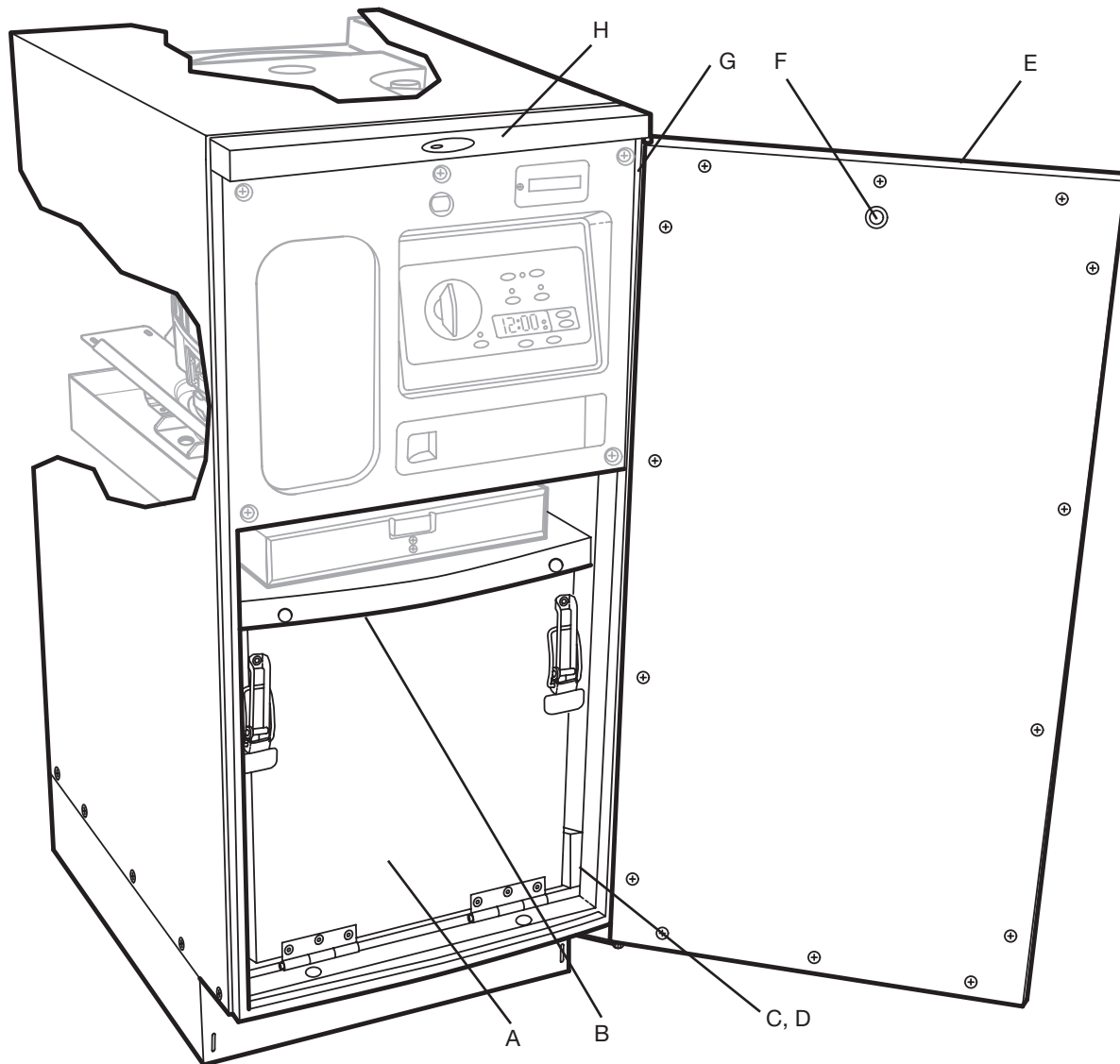

Cabinet

The compactor's main cabinet supports and encloses a number of sub-assemblies. These include the trash bucket, the door, the motor, the ram, and the electrical controls and components.

Legend

- A. Trash Bucket
- B. Bucket Handle
- C, D. Slide Rails
- E. Door Assembly
- F. Safety Interlock Actuator
- G. Gasket Assembly
- H. Top Trim Cover

Trash Bucket

REMOVE

To remove the bucket completely from the cabinet for repairs or cleaning, follow these instructions.

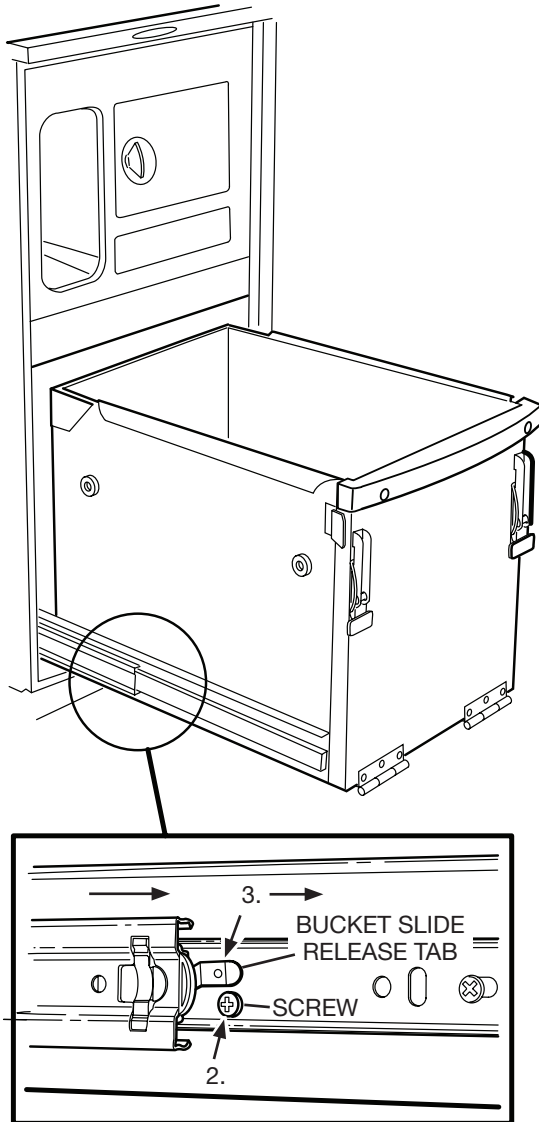

1. Pull out trash bucket until it stops.
2. Remove one screw from each of the bucket slides.
3. Press down on left and right bucket slide release tabs while pulling the bucket out of the cabinet.

Bucket Handle

REMOVE AND REPLACE

The plastic bucket handle may receive a lot of “wear and tear” simply because the operator uses it every time he or she places trash into the compactor, or removes or replaces the bag. If the handle is scratched, chipped or broken, replace it.

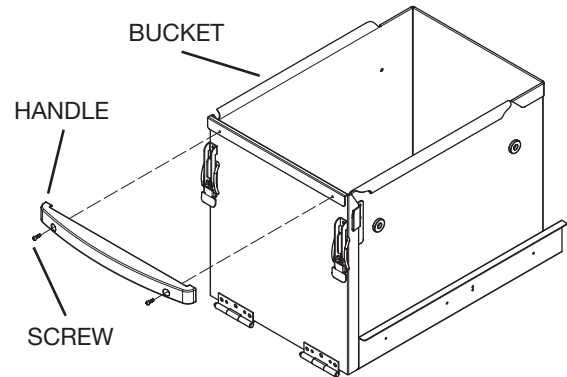

1. Remove two Phillips head screws and detach the handle from the bucket.
2. Installation is the reverse of removal.

Slide Rails (Cabinet)

REMOVE AND RE-INSTALL

The compactor's slide rails may become bent from misuse or the ball bearings may become worn.

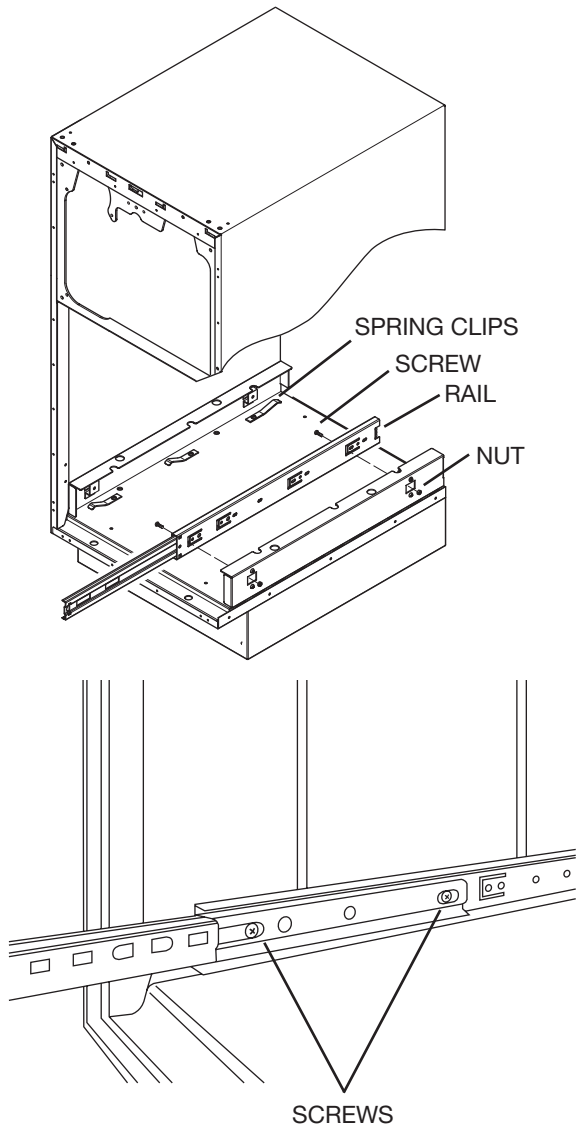

1. Remove trash bucket assembly. (See Trash Bucket, Remove.)
2. Remove two Phillips head screws from the front and rear of the left track slide rail. NOTE: It is necessary to slide the inner rail to access both screws.
3. Remove the slide rail from the cabinet.
4. To re-install, place slide rail onto the three "spring clips" inside of the cabinet. Align holes in rail with bracketed holes on inside of cabinet and secure with two Phillips head screws. Repeat for other side.

Slide Rails (Bucket)

REMOVE AND RE-INSTALL

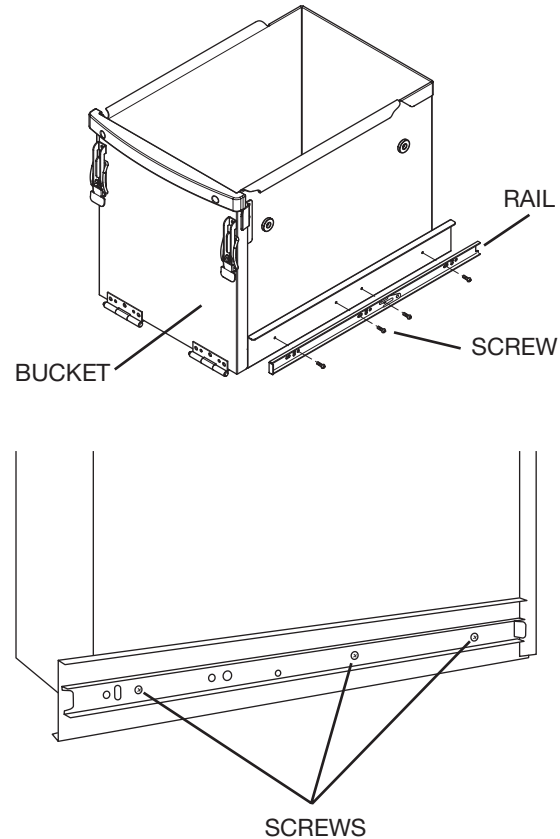

1. Remove four Phillips head screws that secure the left slide rail to the bucket. Remove the rail.
2. Repeat Step 1 for the right slide rail.
3. Installation is the reverse of removal.

Door Assembly

REMOVE AND RE-INSTALL – ALL DOORS EXCEPT WOOD AND TILE

The heavy-duty door could become dented, scratched or bent and require replacement. Door removal is also necessary for some service procedures.

IMPORTANT: Firmly support the door during removal and re-installation.

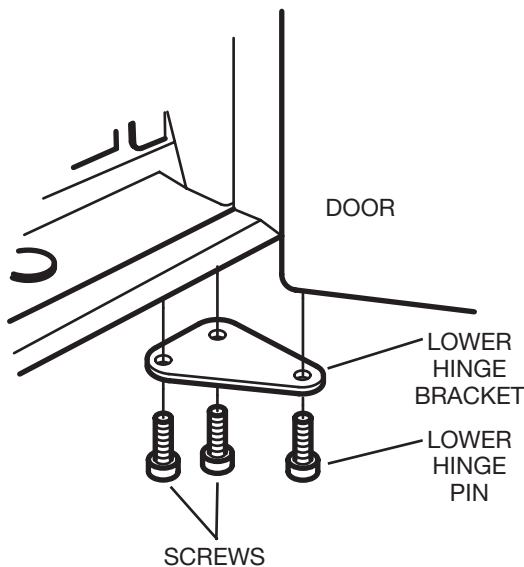

1. With the door closed, use a 3/16" allen wrench to remove the lower hinge pin.
2. Carefully remove door by opening and sliding the bottom of the door away from the cabinet.
3. To re-install, lift the door, insert the upper hinge pin into the upper door bushing and move the door into place. Insert the lower hinge pin from Step 1 and tighten securely.

REMOVE AND RE-INSTALL – WOOD AND TILE DOORS

Use the following instructions for trash compactors with tile or wood door kits. Remove the door to install the custom wood or tile panel or to replace the door. Door removal is also necessary for some service procedures.

IMPORTANT: Firmly support the door during removal and re-installation.

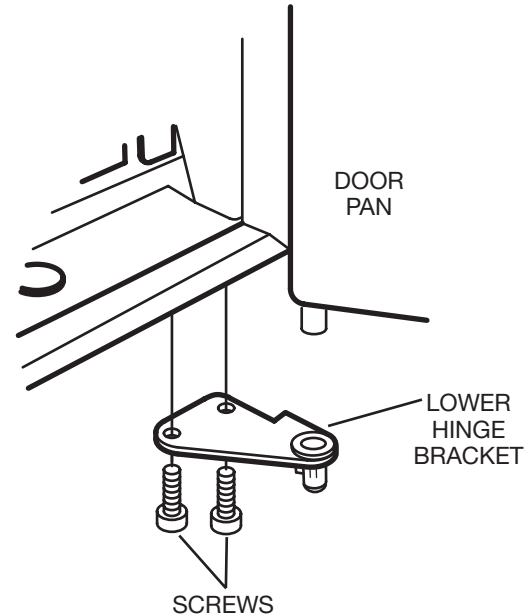

1. Use a 3/16" allen wrench to remove the lower hinge bracket from the cabinet (2 screws).
2. Remove the door pan from the cabinet. If this removal is not for first-time custom installation, proceed to Step 8.
3. The compactor comes from the factory with the door in the right-hand opening position. To reverse the door, see Reverse Door Position – Wood and Tile Doors.
4. Remove the actuator to prevent damage (see Safety Interlock Actuator, Remove and Re-install – Wood and Tile Doors).

For wood door:

5. The wood door pan is designed to accommodate a 3/4" thick wood panel that is 14-7/8" wide by 29-1/4" tall. Verify the height of the door pan prior to cutting the wood panel to size. Center the door pan on the wood panel and fasten together using hardware provided in the compactor parts bag.

For tile door:

- The tile door comes preassembled with cement backer board. Tile and grout the door pan using traditional tiling methods and materials.
- Attach a door handle (not provided) at this time per handle instructions.
- Re-install the actuator (see Safety Interlock Actuator, Remove and Re-install – Wood and Tile Doors).

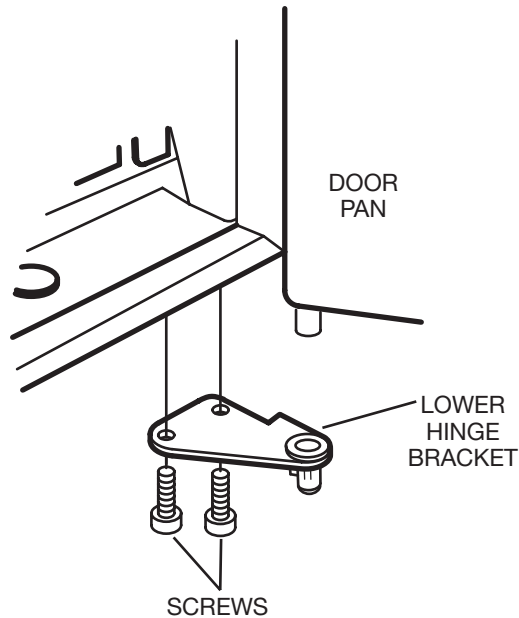

- To re-install, lift the door, insert the upper hinge pin into the upper door bushing and move the door into place. Hold the lower hinge bracket from Step 1 in position with the lower bushing on the lower hinge pin. Insert the 2 screws and tighten securely.
- Make sure the door opens and closes smoothly with the actuator entering and exiting the door interlock switch on the cabinet.

REVERSE DOOR HINGE POSITION – ALL DOORS EXCEPT WOOD AND TILE

The compactor comes from the factory with the door in the right-hand opening position. Use the following instructions to reverse the door.

- Remove the door (see Remove and Re-install – All Doors Except Wood and Tile).

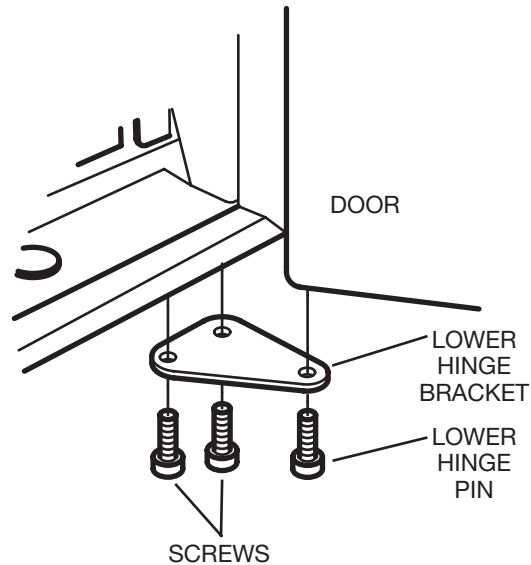

- Use a 3/16" allen wrench to remove the lower hinge pin from the cabinet (2 screws).

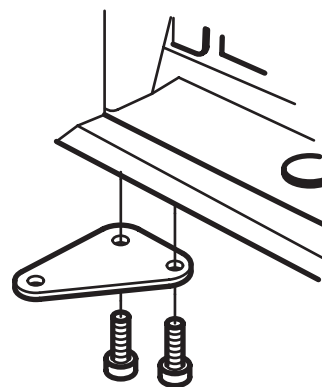

- Turn the bracket over and install the bracket on the opposite side of the cabinet using the same screws.

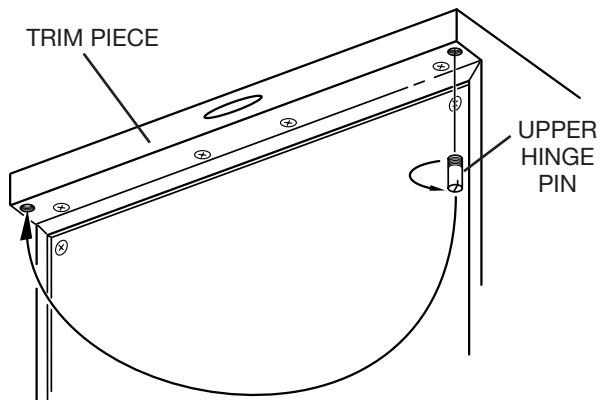

- Use a screwdriver to remove the upper hinge pin from the trim piece and re-install the pin on the opposite side.

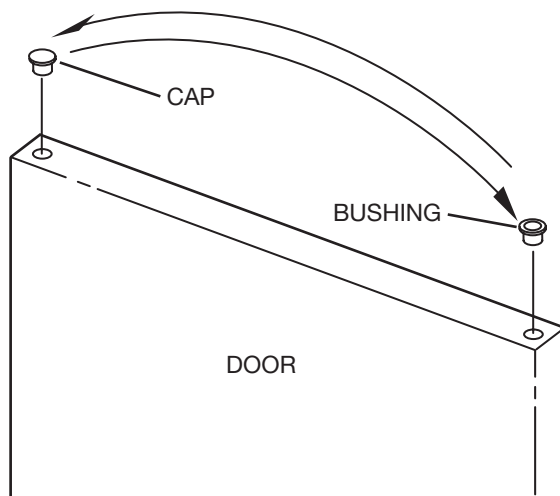

- Being careful not to scratch the door, remove the plastic door bushing and cap from the top and bottom of the door using a small flat screwdriver. Install the bushings on the side of the door panel that will be hinged and install the caps on the opposite side.
- Re-install the door (see Remove and Re-install – All Doors Except Wood and Tile).

REVERSE DOOR HINGE POSITION – WOOD AND TILE DOORS

The compactor comes from the factory with the door in the right-hand opening position. To reverse the door, use the following instructions for trash compactors with tile or wood door kits. On these door pans, the hinge pins are permanently attached.

- Remove the door pan from the cabinet (see Remove and Re-install – Wood and Tile Doors).
- Remove the actuator (see Safety Interlock Actuator, Remove and Re-install – Wood and Tile Doors).

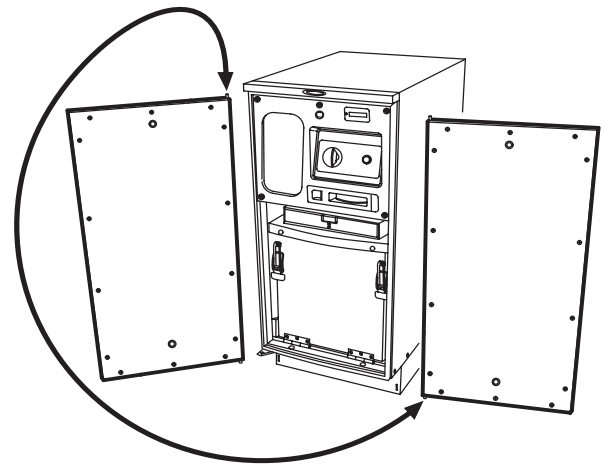

- Rotate the door pan until the hinge pins are on the desired side.
- Locate the lower hinge bracket and screws removed from the cabinet during door removal.

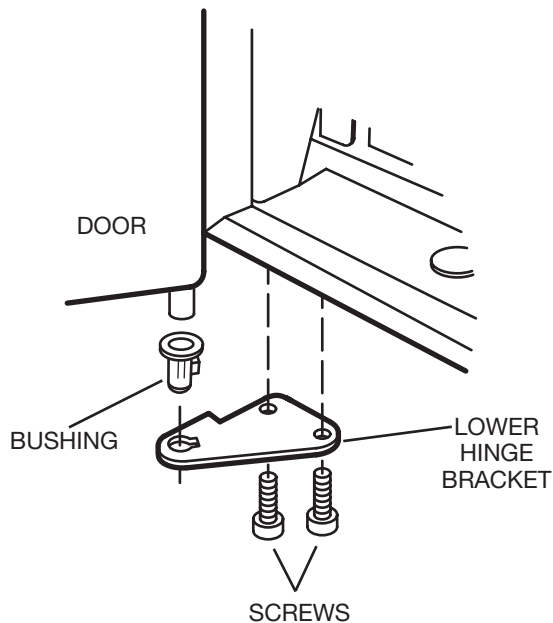

5. Remove the plastic bushing from the hinge bracket, turn the bracket over, and install the bushing on the opposite side.
6. Re-install the door pan on the other side of the cabinet using the new lower bracket configuration (see Remove and Re-install – Wood and Tile Doors).
7. Install the actuator at its new position near the top of the door pan (see Safety Interlock Actuator, Remove and Re-install – Wood and Tile Doors).

Safety Interlock Actuator

REMOVE AND RE-INSTALL – ALL DOORS EXCEPT WOOD AND TILE

This safety device prevents the compactor from operating except when the door is closed. NOTE: If the interlock actuator should break off, the compactor will not function; replace it promptly.

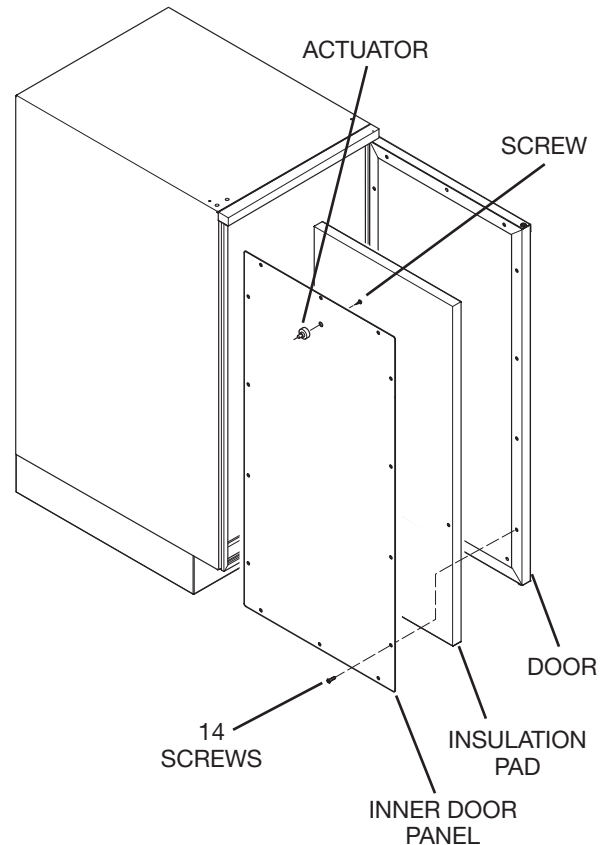

1. Remove the 14 Phillips head screws from the inner door panel. Remove panel and set aside.
2. Remove insulation pad from door.
3. Remove Phillips head screw from inside of door panel and remove actuator.
4. Installation is the reverse of removal. NOTE: Fully seat actuator in the door panel before re-installing screw.

REMOVE AND RE-INSTALL – WOOD AND TILE DOORS

Use the following instructions for trash compactors with tile or wood door kits. Remove the actuator to install the custom wood or tile panel, to reverse the door or to replace the actuator.

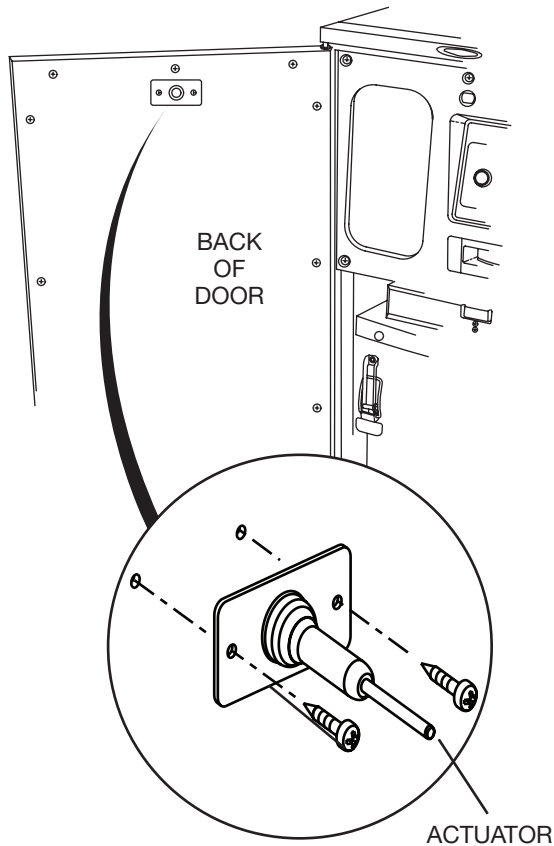

1. Remove the 2 screws that hold the actuator in place. Save the screws.
2. Re-install using the 2 screws from Step 1.
3. After any maintenance involving removing the actuator, make sure the door opens and closes smoothly and the actuator enters and exits the interlock switch.

Gasket Assembly

REMOVE AND RE-INSTALL

The gasket is made of a flexible vinyl material with imbedded magnets. Over time it may become brittle or cracked, and lose its flexibility. If this happens the door may not close properly, so replace the gasket.

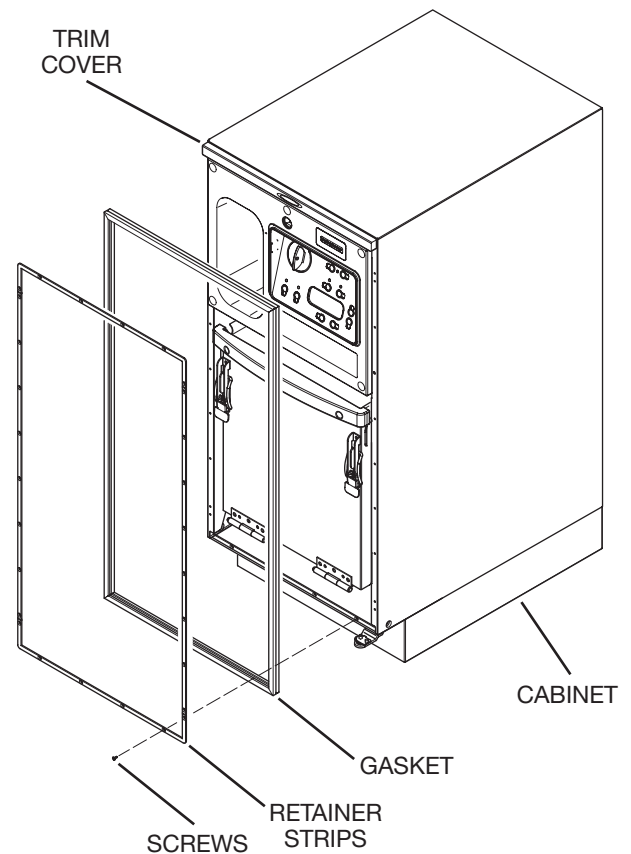

1. Remove door assembly (see Door Assembly, Remove and Re-install).
2. Remove control panel (see *Electrical Components, Control Panel Assembly*).

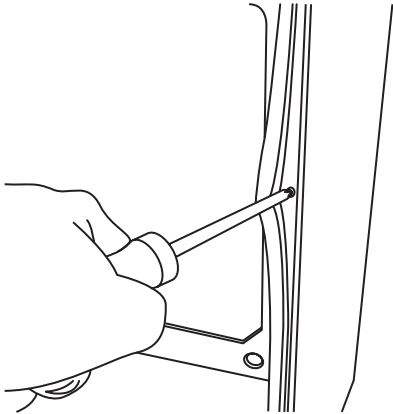

3. Lift the outer edge of the gasket to expose the retainer strips and the screws that are used to fasten the strips to the cabinet. NOTE: There are six retainer strips: two each on the top and bottom and one each for the left and right sides.
4. Remove the Phillips head screws that secure the retainer strips to the cabinet; then remove the strips from underneath the gasket. Pull the gasket off of the cabinet.
5. To install a new gasket, place retainer(s) under the outer edge of the gasket, then use the screws to fasten the retainers and gasket to the cabinet.
6. Re-install the control panel.

Top Trim Cover Assembly

REMOVE AND RE-INSTALL

1. Remove the door (see Door Assembly, Remove and Re-install).

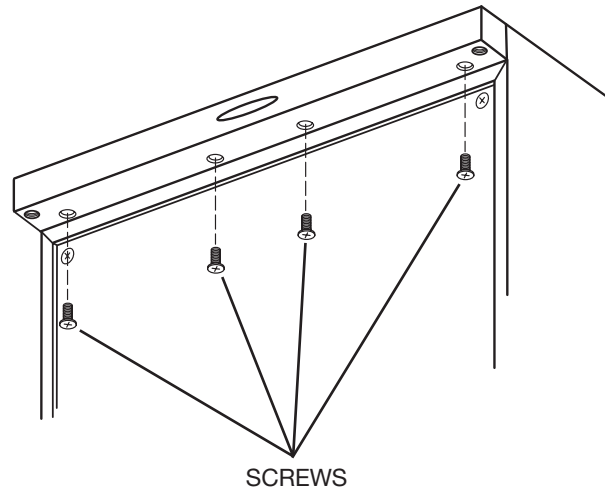

2. Remove the four Phillips head screws that secure the top trim cover to the cabinet.

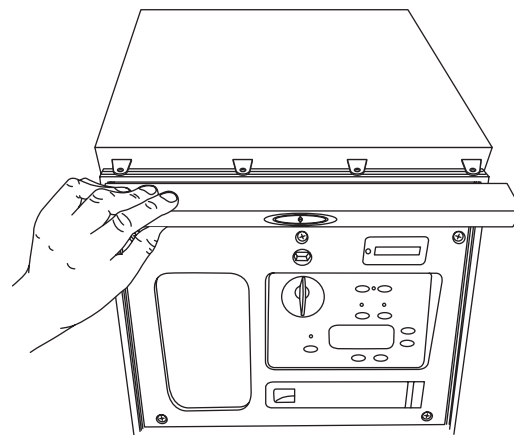

3. Pull the top trim cover away from the cabinet.
4. Re-install in reverse order. Be careful not to over-tighten screws.

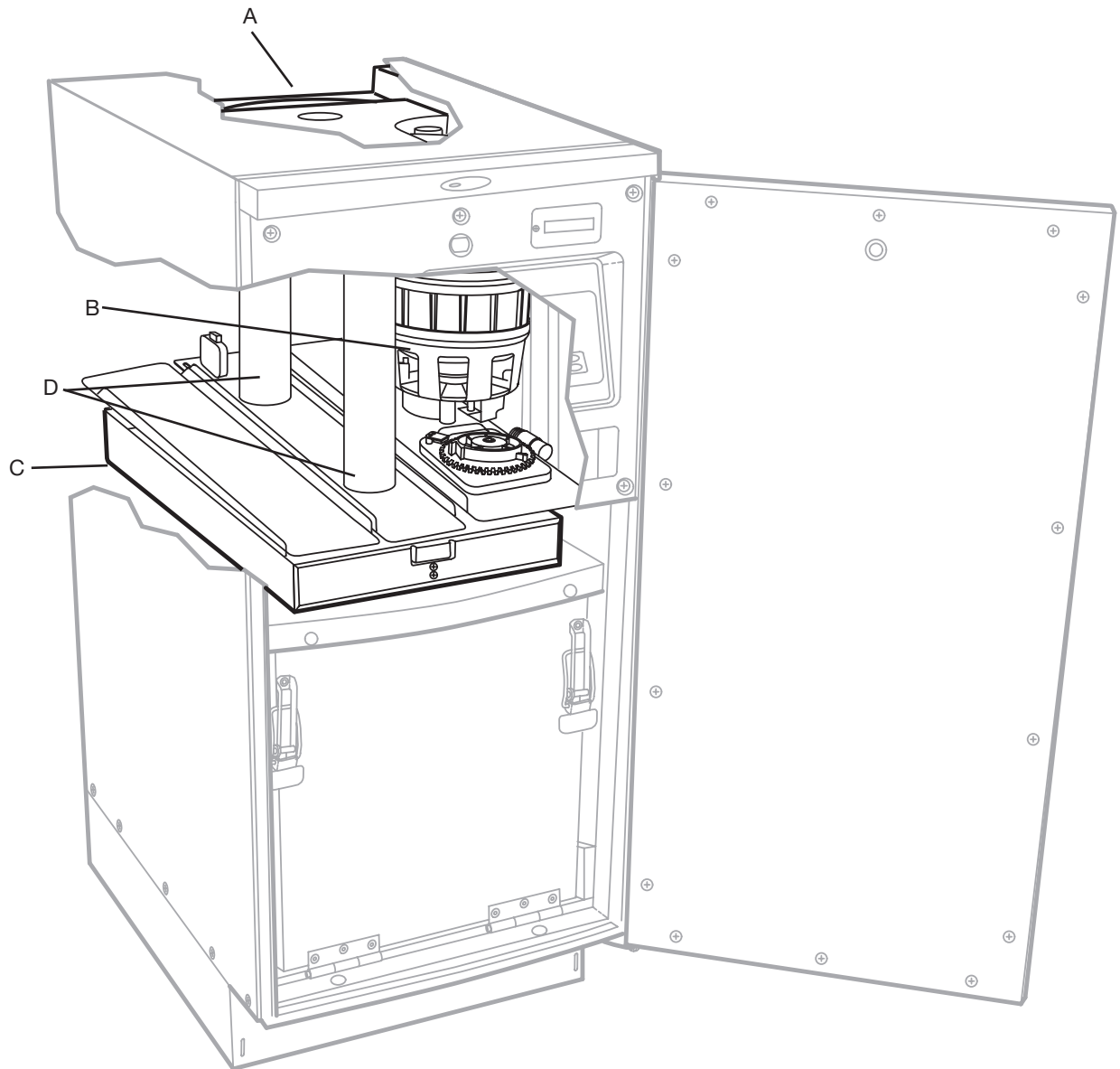

Legend

- A. Drive Belt
- B. Main Motor
- C. Complete Power Unit Mechanism
- D. Ram Screw Assembly

Drive Belt

REMOVE AND RE-INSTALL

The drive belt transfers power from the motor to the ram screws. If it requires replacement, follow these steps.

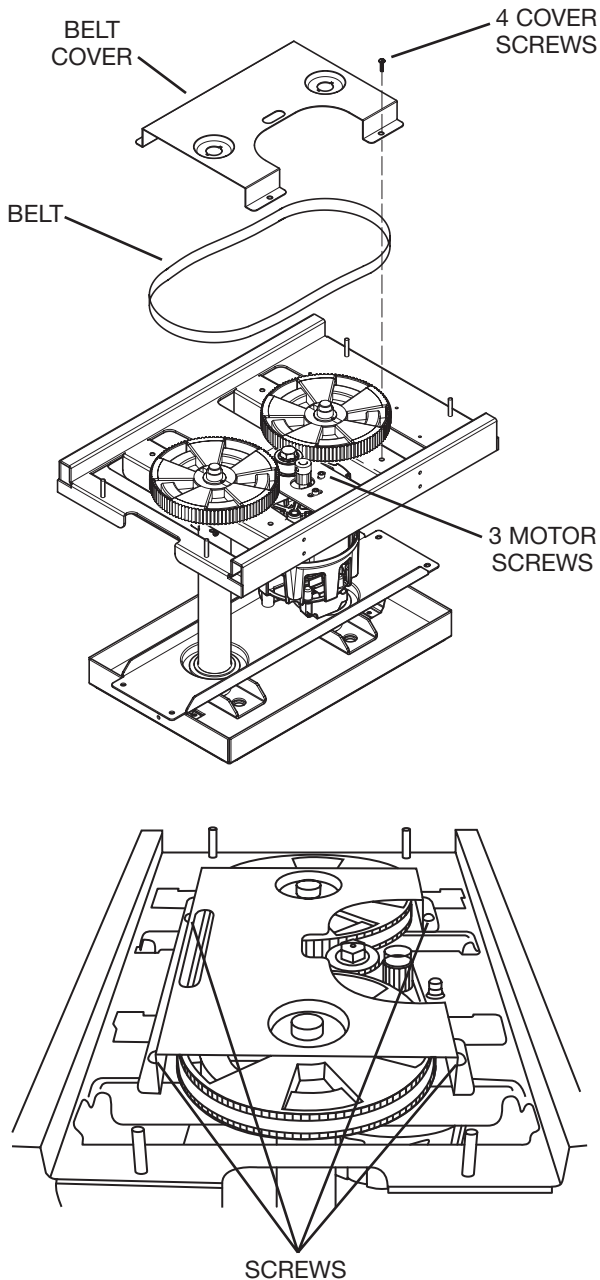

1. Remove cabinet cover (see *Electrical Components, Access to Components*).
2. Remove the four Phillips head screws that secure the belt cover to the unit.

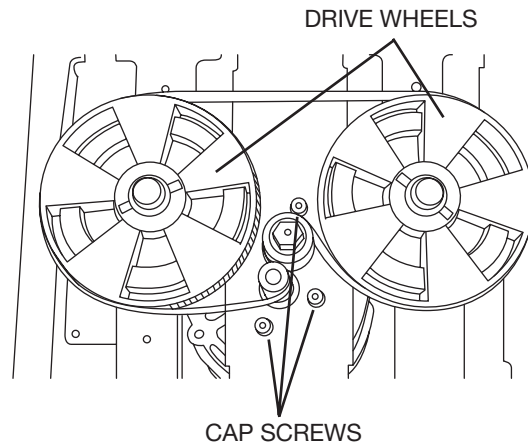

3. Use a 5 mm hex wrench to loosen the three hex head cap screws. Rotate motor to loosen belt for removal.

IMPORTANT: Before installing a new drive belt, follow the instructions below to align the height of both ram screws.

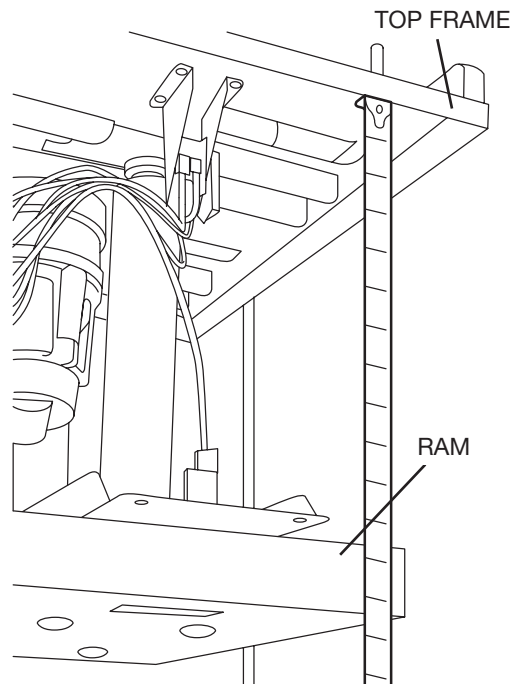

4. Measure the distance from the underside of the top frame to the bottom edge of the ram at the front and rear of the power unit.
5. If the measurements are different, rotate the ram screw drive wheels as necessary until the measurements match.
6. Install new belt, making sure it seats properly in gear teeth. Adjust the belt tension by rotating the motor until the belt deflection is 1/2 inch. Tighten the three hex head cap screws securely. Re-install the belt cover.

Main Motor

REMOVE AND REPLACE

Follow these instructions if it becomes necessary to replace the main motor.

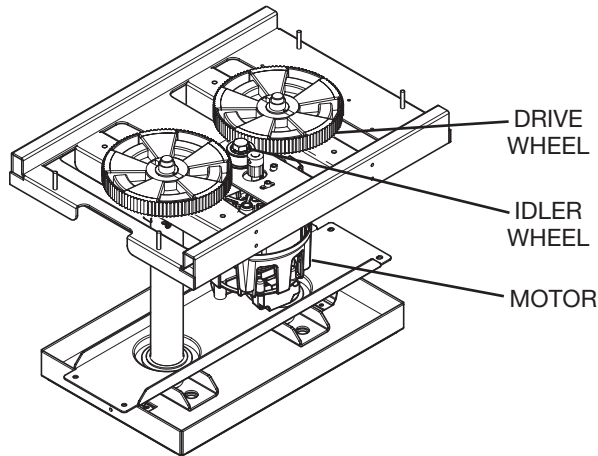

1. Remove cabinet cover (see *Electrical Components, Access to Components*).
2. Remove the belt cover and drive belt (see above) and follow the steps in *Drive Belt, Remove and Re-install*.
3. Mark the location of all wire connections and ties on the motor, then disconnect the wires.

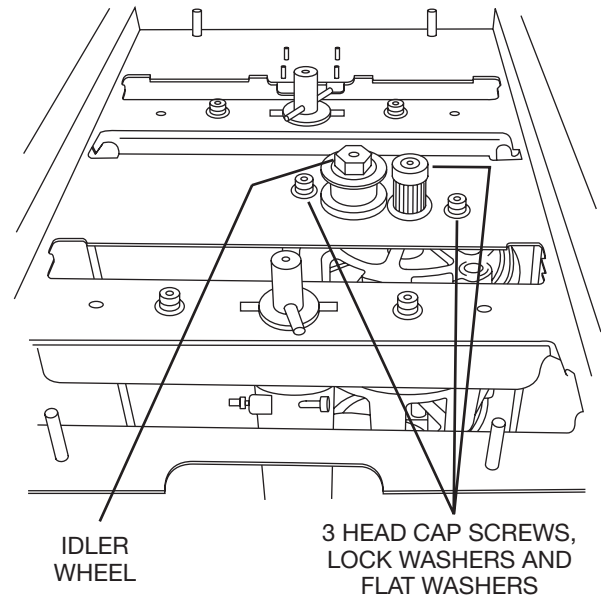

NOTE: For illustration purposes, the view is shown with the drive wheels removed.

4. Use an open-end, socket or crescent wrench to remove the idler wheel.
5. Support the motor from underneath and remove the three head cap screws, lock washers and flat washers. Remove the motor.
6. Re-assemble in reverse order. Adjust the belt tension by rotating the motor until the belt deflection is 1/2 inch.

Complete Power Unit Mechanism

REMOVE AND RE-INSTALL

The complete power unit mechanism consists of the ram screw assemblies, the motor and the drive belt. Rather than replace individual components, it may be easiest to replace the whole mechanism.

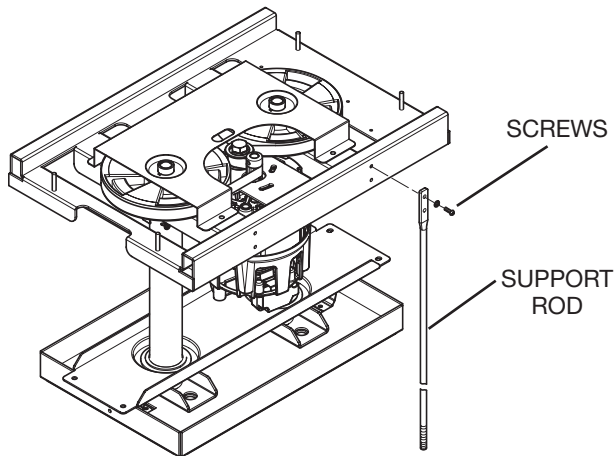

1. Remove cabinet cover (see *Electrical Components, Access to Components*).
2. Mark the location of all wire ties.

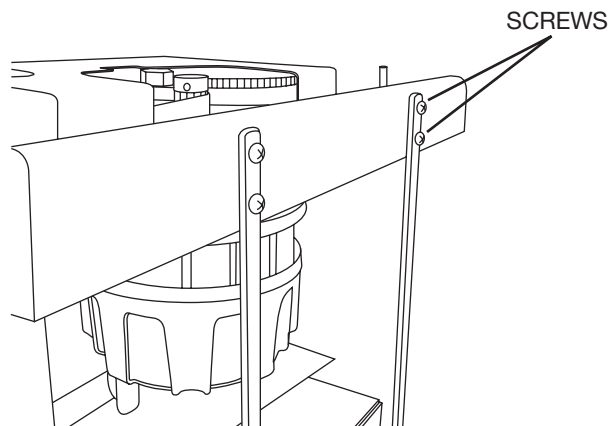

3. Support the power unit and remove the two Phillips head screws from each of four support rods.
4. Remove the power unit mechanism.
5. Installation is the reverse of removal.

Drive Wheels

REMOVE AND REPLACE

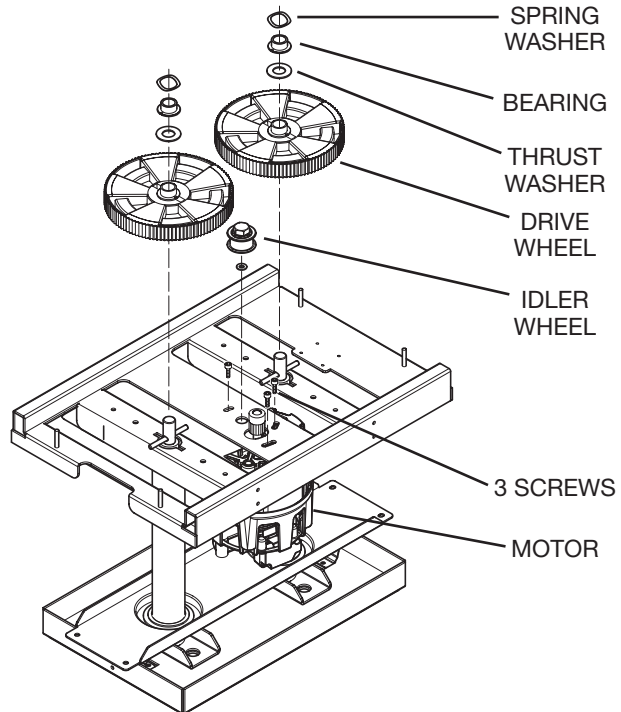

1. Remove cabinet cover (see *Electrical Components, Access to Components*).
2. Remove the belt cover and drive belt (see above) and follow the steps in *Drive Belt, Remove and Re-install*.
3. Remove spring washer, bearing and thrust washer from each drive wheel and remove both drive wheels. NOTE: Grease the spring washer, bearing and thrust washer before re-installing.

Ram Screw Assembly

REMOVE AND REPLACE

The ram screw assemblies transfer power to the ram and plate. Heavy usage can damage the threaded rod. If it becomes necessary to replace one or both of the ram screw assemblies, follow the instructions below.

1. Remove cabinet cover (see *Electrical Components, Access to Components*).
2. Remove the drive belt (see *Drive Belt, Remove and Re-install*).
3. Remove drive wheels (see *Drive Wheels, Remove and Replace*).

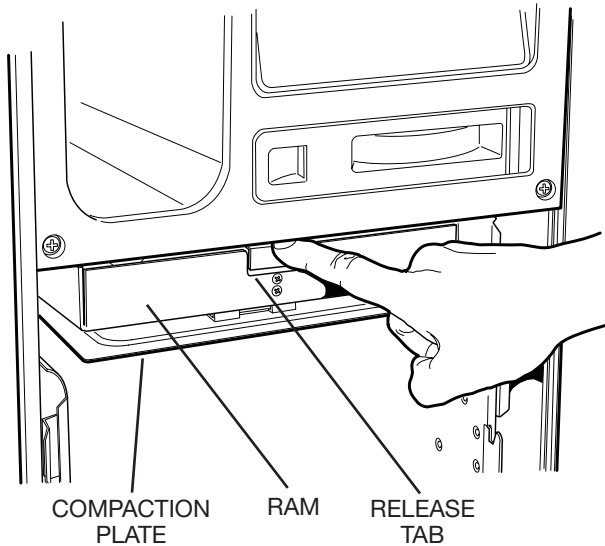

4. Remove the compaction plate by releasing the tab on the front of the ram, and pulling the plate down and away from the ram. **NOTE:** When re-installing the plate, insert the rear tab into the slot at the rear of the ram, then press up on the front of the plate until it latches securely in place.

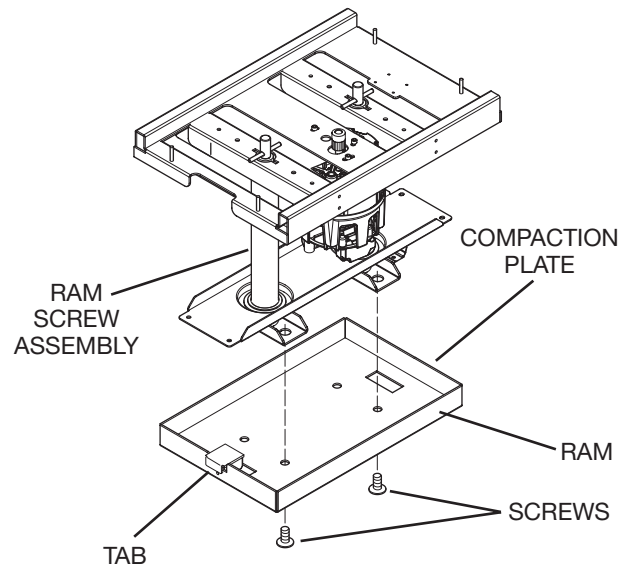
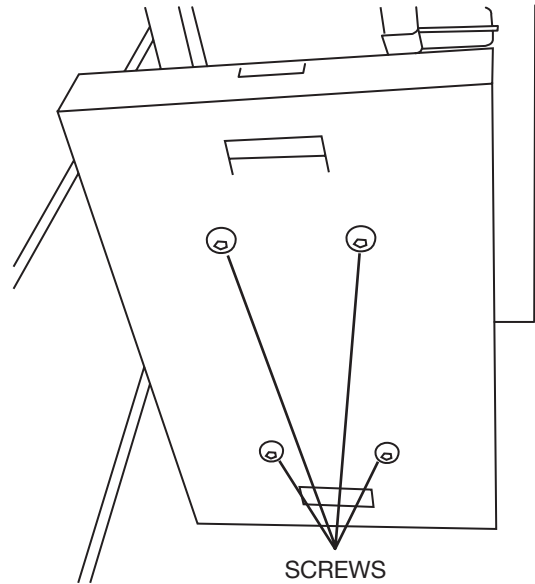

5. Remove the four hex head screws and the ram from the bottom of the ram screw assembly.

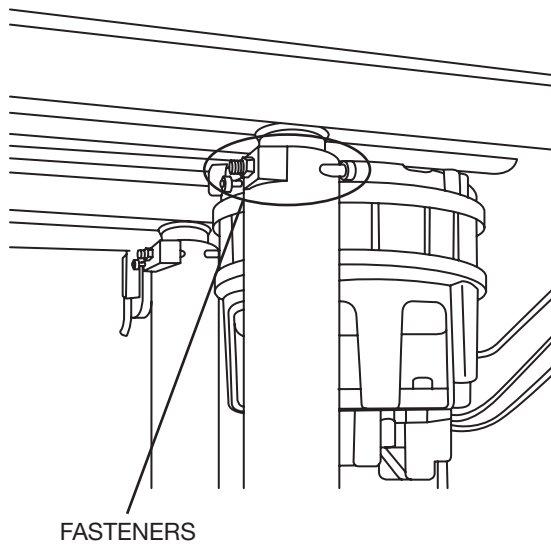

6. Remove two hex head screws, shims, brackets and nuts (fasteners) from the top of the ram screw assembly. Note orientation of bracket during removal as they activate the limit switches.

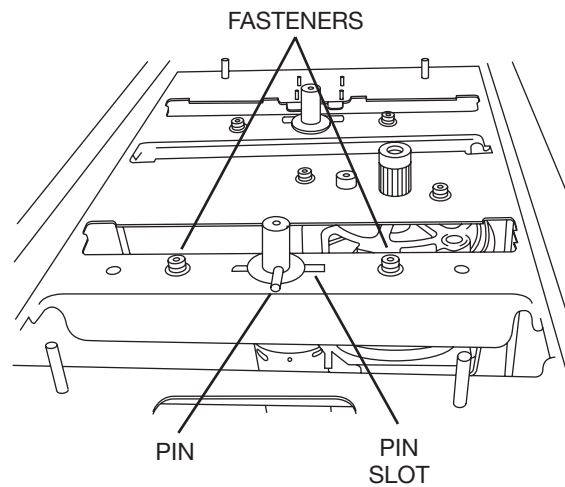

7. Turn the ram until the top pin indexes 90° from the pin slot; remove two hex screws, lock washers and flat washers (fasteners).
8. Turn the ram as required to align the ram pin with the slot in the top frame and lower the ram through the hole.

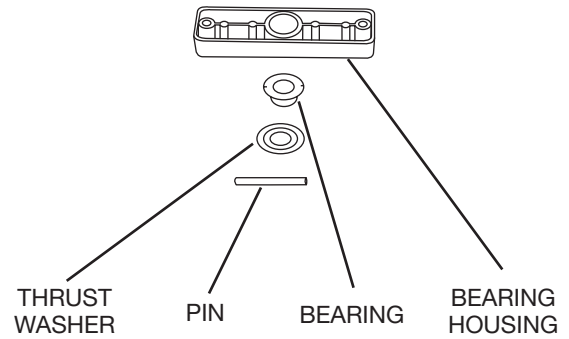
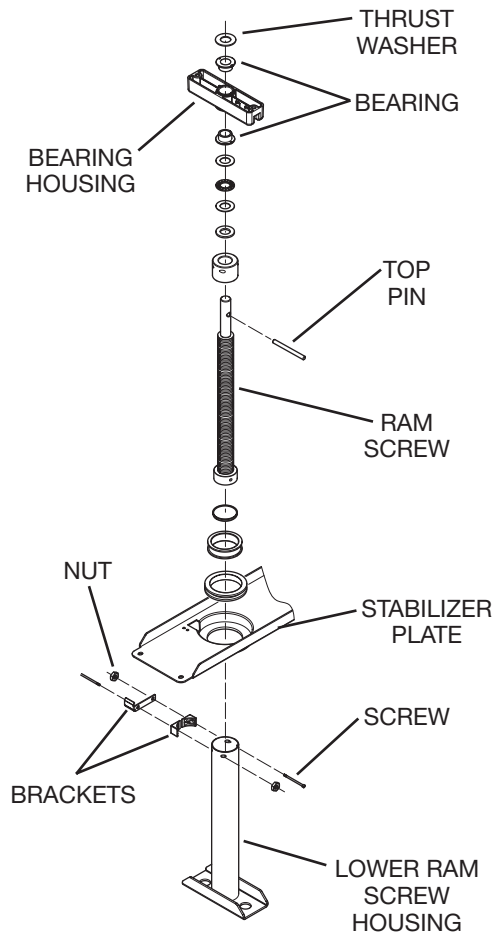

9. Remove the pin, thrust washer, bearing, and upper bearing housing from the ram.
10. Lower the ram screw assembly through the center stabilizer plate.

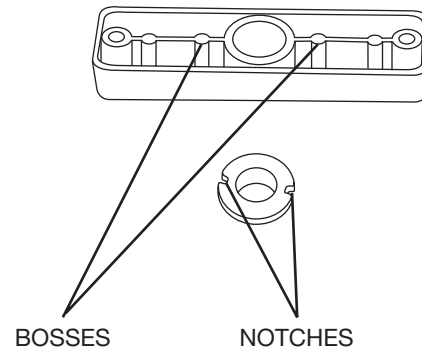

IMPORTANT: On re-assembly, index the bosses on the top bearing housing with the corresponding notches in the bearing. Brackets must be positioned correctly as they activate the limit switches. See illustration at left.

11. Re-assembly is the reverse of disassembly.

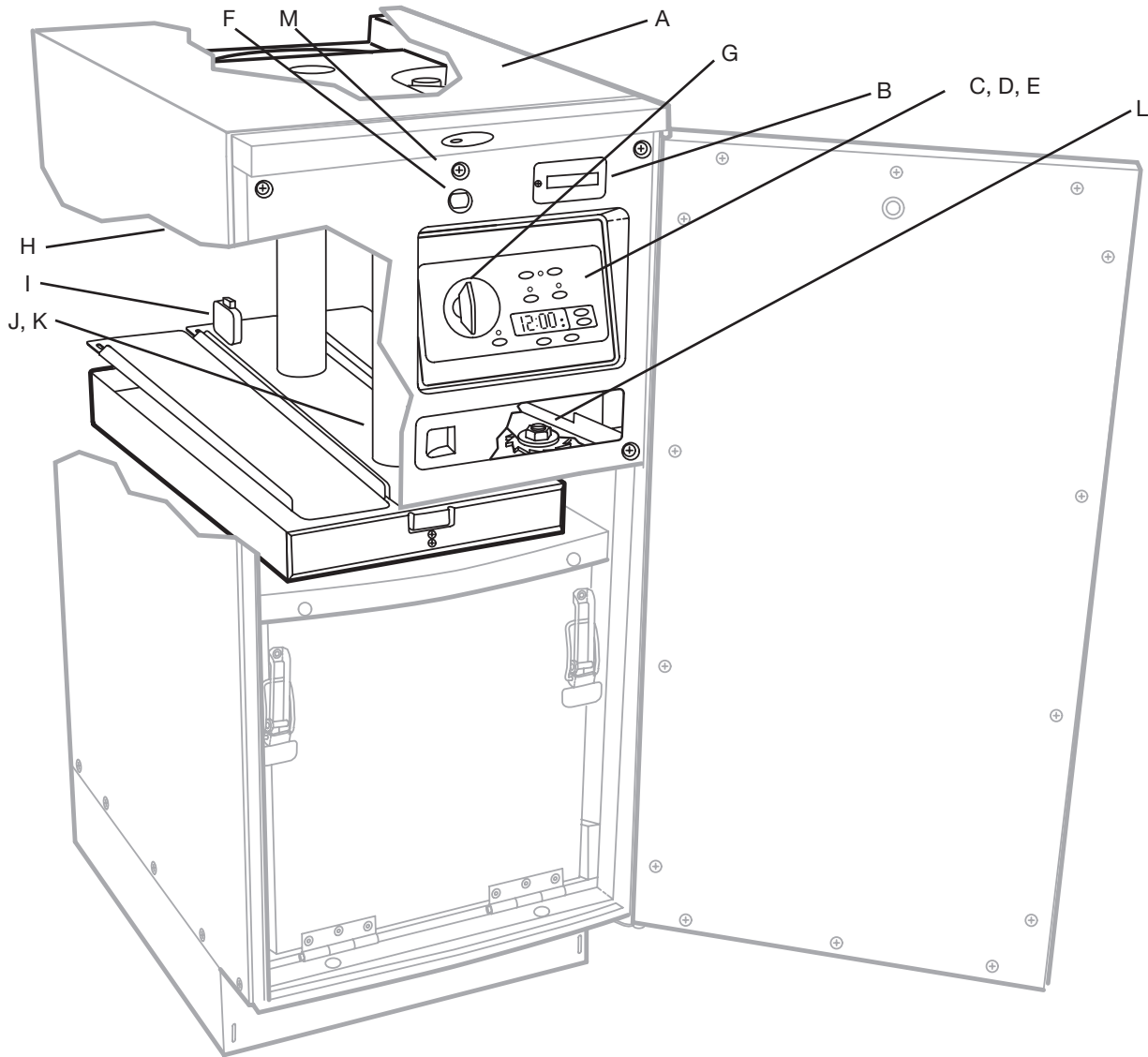

Legend

- A. Cabinet Cover
- B. Control Panel Assembly
- C. Display Module Assembly
- D. Power Supply Board
- E. Control Board
- F. Cabinet Safety Interlock Switch
- G. Key Switch Assembly
- H. Upper Limit Switch Assembly
- I. Lower Limit Switch
- J. Motor Centrifugal Switch Assembly
- K. Motor Capacitor
- L. Odor Disk Gear Motor Assembly
- M. Start Switch

Start Switch

REMOVE AND REPLACE

The start switch is located inside of the cabinet, behind the push button assembly.

1. Remove control panel assembly (see Control Panel Assembly, Remove and Re-install).
2. Remove start switch (2 screws).

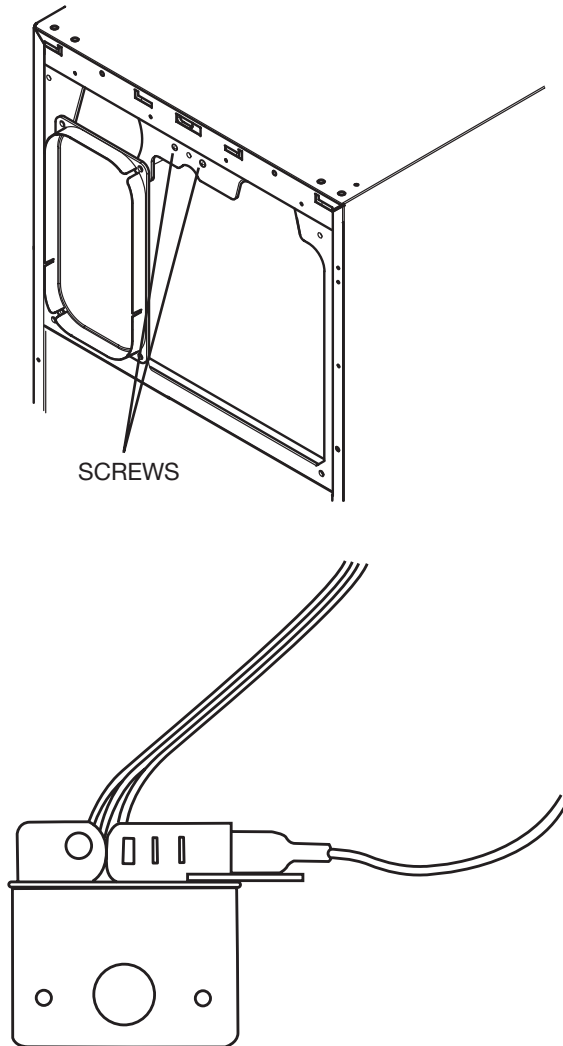

3. Installation is the reverse of removal.

Access to Components

In order to access the electrical components, it is first necessary to remove the cabinet cover.

REMOVE CABINET COVER

1. Remove the bucket from the compactor (see *Cabinet, Trash Bucket*).
2. Remove the door assembly, the (2) bottom door gasket retainers (see *Cabinet, Door Assembly*).
3. Remove the back panel by first removing the Phillips head screw that secures the power cord cable clamp to the back panel, and then removing the 16 screws that secure the panel to the cabinet.

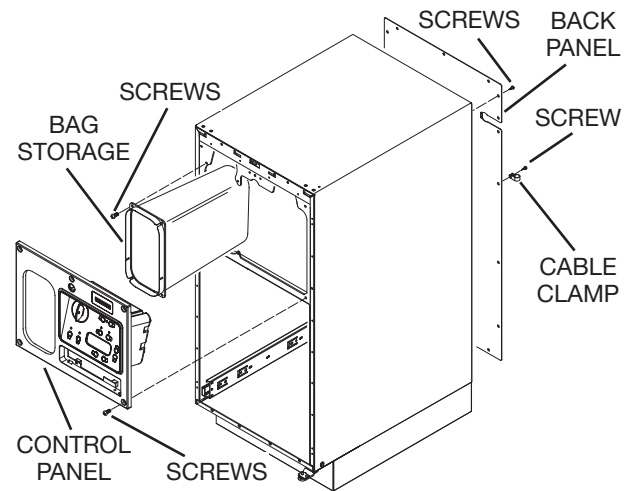

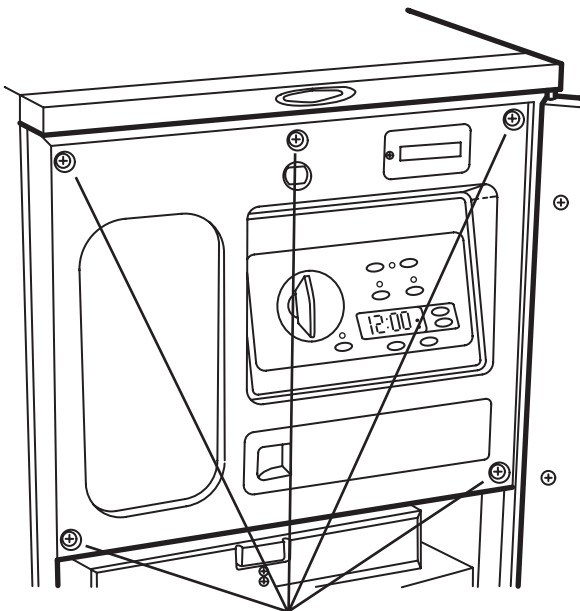

SCREWS

4. Remove control panel assembly (see Control Panel Assembly, Remove and Re-install).

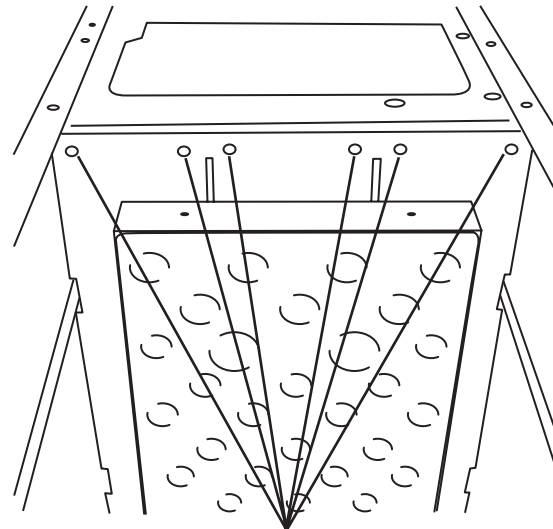

SCREWS

6. Remove six Phillips head screws each that secure the front and rear of the stabilizer plates to the cabinet cover (rear view shown).

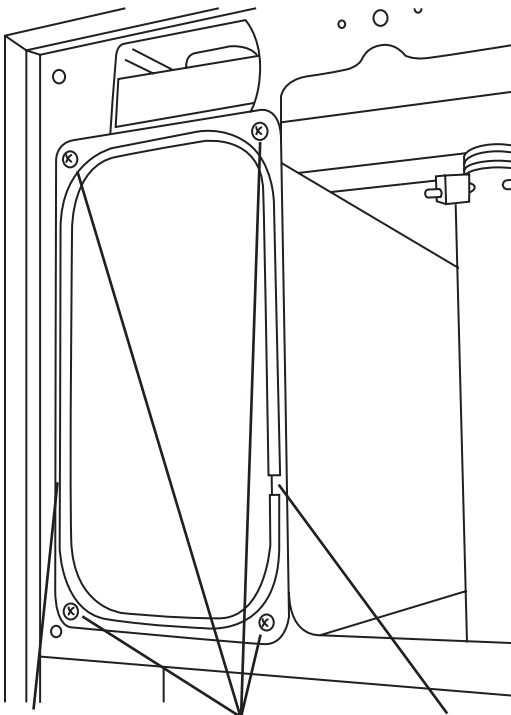

NOTCH

SCREWS

NOTCH

5. To remove the bag storage, remove four Phillips head screws that secure it to the cabinet. NOTE: Upon reassembly, the notches on the right and left sides must appear on the lower part of the bag storage.

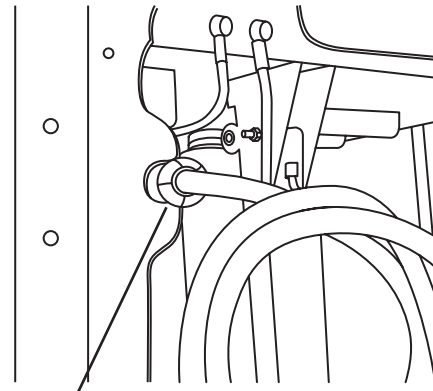

GROMMET

7. To remove the power cord at the back of the unit, rotate the power cord grommet 90° to the right, then slide the cord out of the slot. Temporarily place the cord in the rear of the power unit assembly to keep it out of the way.

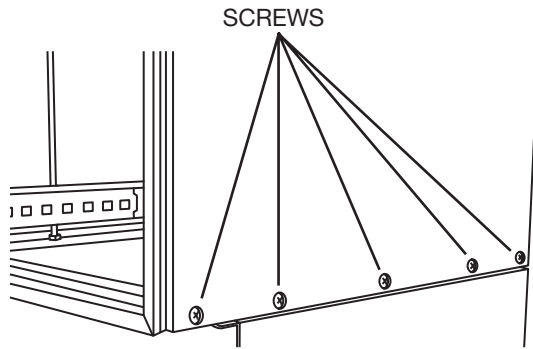

8. Remove five Phillips head screws each from the lower right and left sides of the cabinet cover.

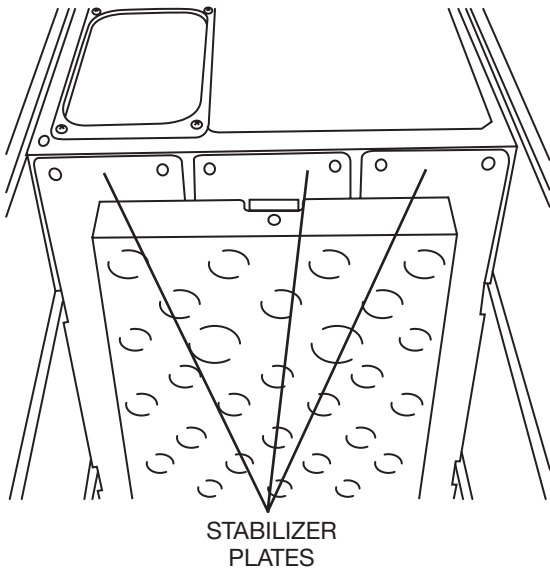

9. Gently spread lower left and right sides of the cabinet cover apart and raise a few inches to allow the left and right stabilizer plates to be removed. Take care not to damage or tear the gasket. Tilt the bottom front of the cabinet cover forward and up while raising the cover.
10. Grasping the front and rear edges of the cover, raise it up a few inches and allow it to rest temporarily on the four locator pins. Remove the left and right stabilizer plates. Again grasp the front and rear edges of the cover and lift it off the unit, tilting it forward and back as required.

RE-INSTALL CABINET COVER

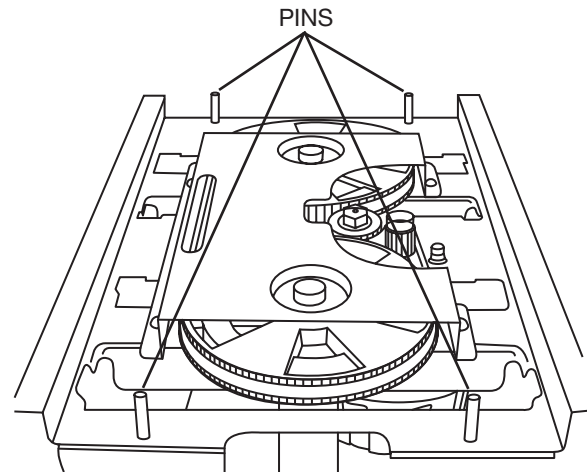

1. To re-install the cabinet cover, lift the cover over the top of the unit and allow it to rest temporarily on the top of the locator pins.
2. Insert the right and left stabilizer plates but do not secure them in place (they will rest temporarily on top of the ram). Gently move the cover so that the front and rear pins slide into their respective rubber grommets. Make sure the sound-deadening material fits properly down the sides of the cabinet.
3. Using six Phillips head screws (front and rear), secure the three stabilizer plates to the cabinet. NOTE: The stabilizer plates rest below the front and rear cross-members (see illustration above).
4. Re-install the bag storage, control panel, cabinet cover, bucket and door, etc., in reverse order.

Control Panel Assembly

REMOVE AND RE-INSTALL

The control panel assembly houses the display panel, the safety interlock switch, the battery backup compartment, the bag storage, and the odor control disk tray.

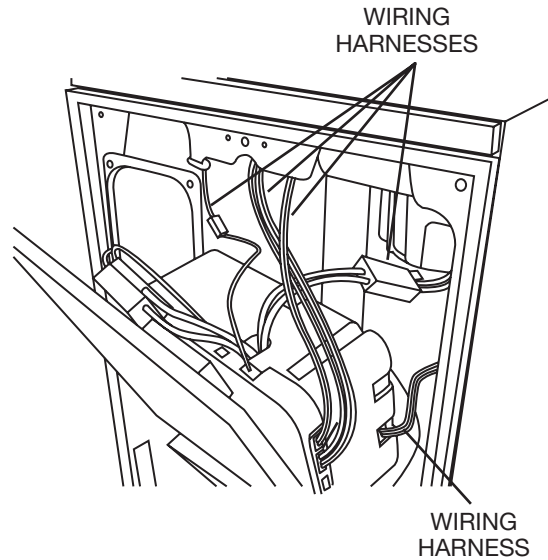
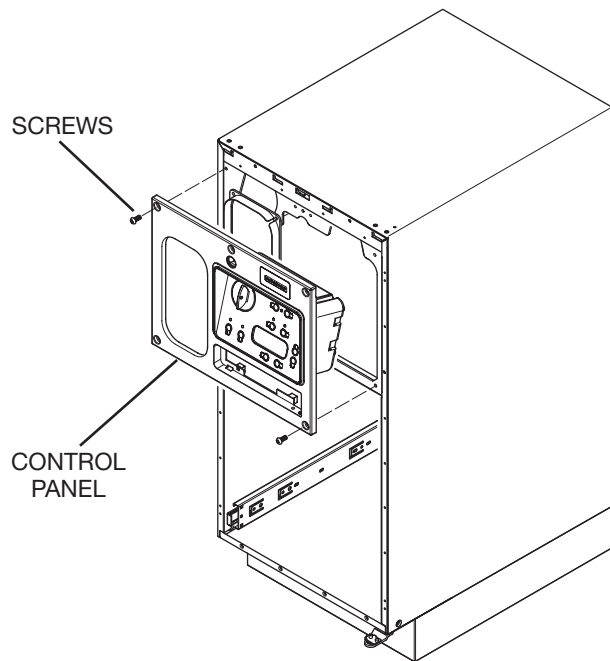

2. After removing these five screws, open odor disk tray, pull the panel away from the cabinet and disconnect the five wiring harnesses.
3. Installation is the reverse of removal.

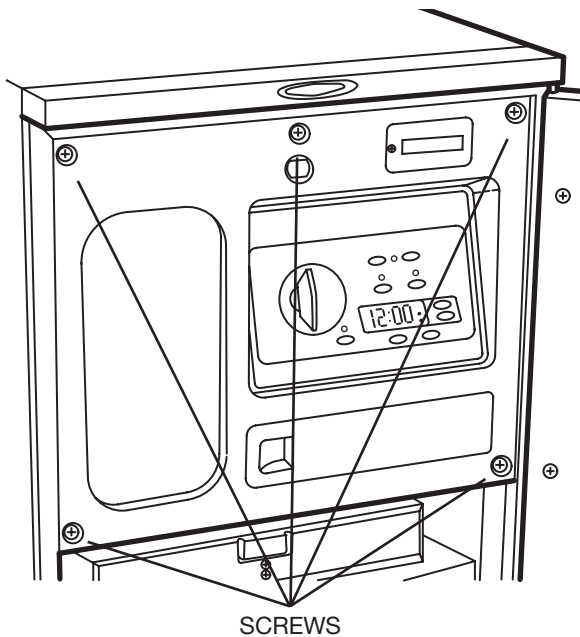

1. On the front of the unit, remove the five Phillips head screws that secure the control panel assembly to the cabinet cover.

Display Module Assembly

REMOVE AND RE-INSTALL

The display module assembly contains switches and LEDs that allow the operator to turn the compactor ON and OFF, and to place it in LOCK mode; to select HOLD or NORMAL mode; to start the compactor cycle; to set the clock and delay mode; to monitor odor control, and to reset and advance the odor control disk. If LEDs or switches are worn, replace the display module.

1. Remove the control panel assembly from the unit (see Control Panel Assembly, Remove and Re-install).

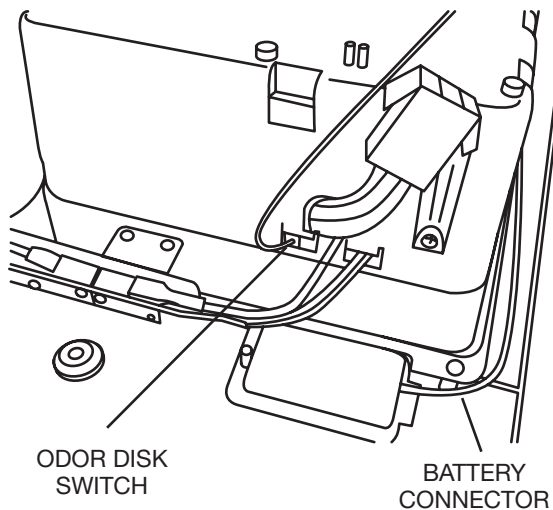

2. Disconnect the battery connector and odor disk switch from the control panel.

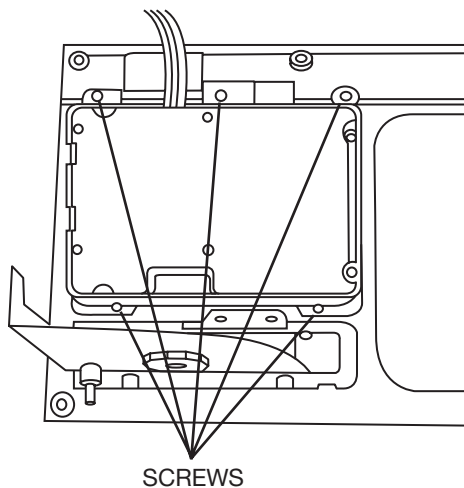

3. Remove five Phillips head screws and the display module assembly from the control panel.
4. Installation assembly is the reverse of removal. NOTE: First install display module assembly to panel, then re-attach wiring.

Power Supply Board

REMOVE AND RE-INSTALL

The power supply board directs electrical power to all areas of the compactor, including the control board, the main motor and the odor control motor.

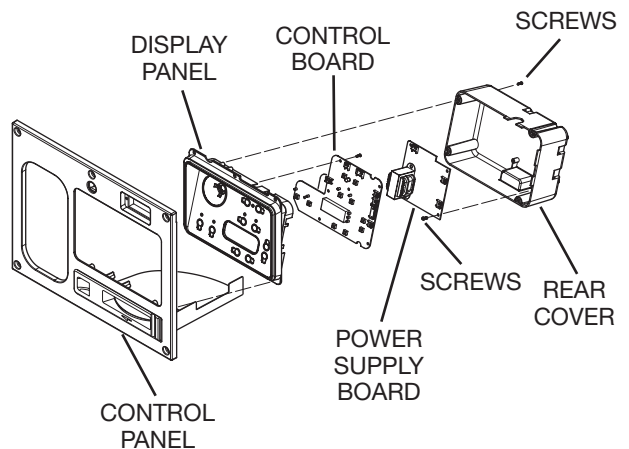

1. Remove the control panel and display module assembly (see Control Panel Assembly, Remove and Re-install and Display Module Assembly, Remove and Re-install).

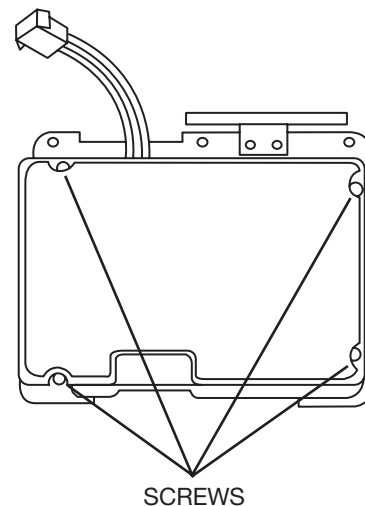

2. Remove four Phillips head screws from the display module assembly rear cover.

Control Board

REMOVE AND RE-INSTALL

The control board is used to electronically connect the compactor's electronic components.

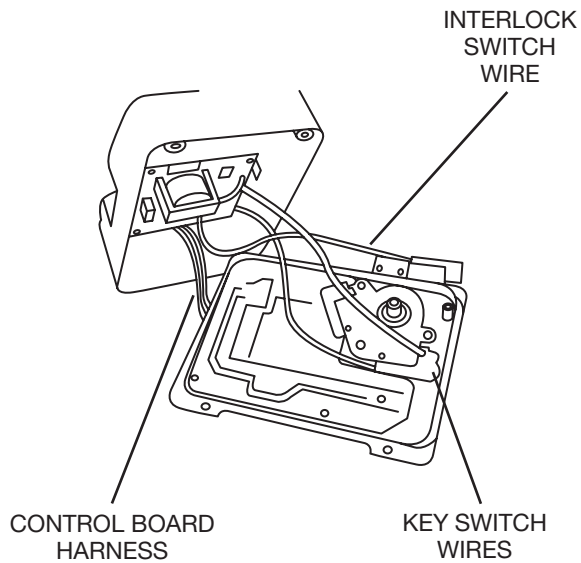

3. Lifting the cover and noting their locations, firmly but gently disconnect the control board harness, the wire at the interlock switch, and the key switch wires. Remove the rear cover. NOTE: Illustration does not show control board insulator.

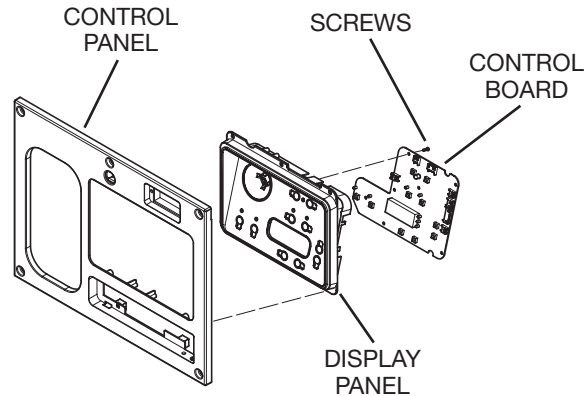

1. Remove the control panel assembly (see Control Panel Assembly, Remove and Re-install). Remove rear cover from the display module assembly (see Display Module Assembly, Remove and Re-install).

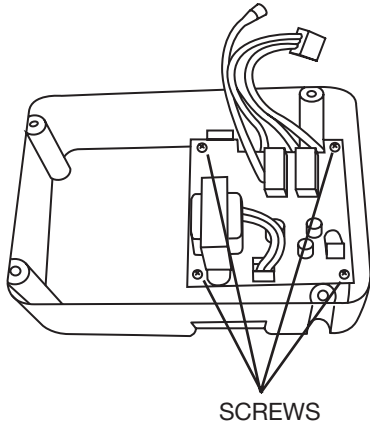

4. Remove four Phillips head screws and the power supply board from the rear cover.
5. Installation is the reverse of removal.

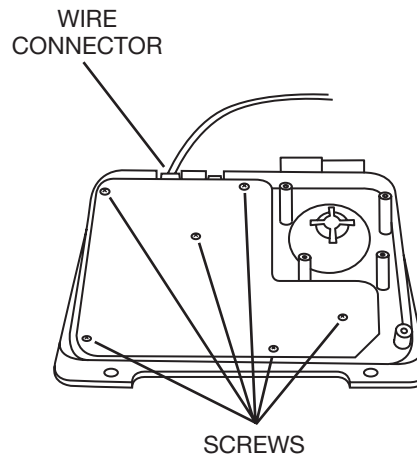

2. Remove the wire harnesses from control board (Note wire locations).

NOTE: In this illustration, the key switch and control board insulator have been removed for clarity.

3. Remove six Phillips head screws, the printed circuit board, and the insulator from the display module frame.
4. Installation is the reverse of removal.

Key Switch

REMOVE AND REPLACE

Part mechanical, part electrical, the key switch gives the operator three options: ON, OFF and LOCK.

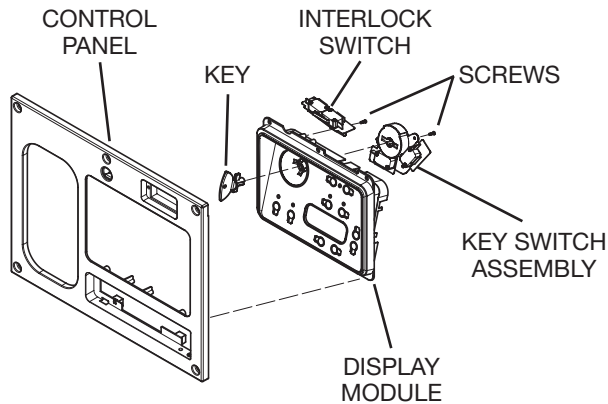

1. Remove the control panel assembly (see Control Panel Assembly, Remove and Re-install) and the display module. Remove the display module rear cover and the key.

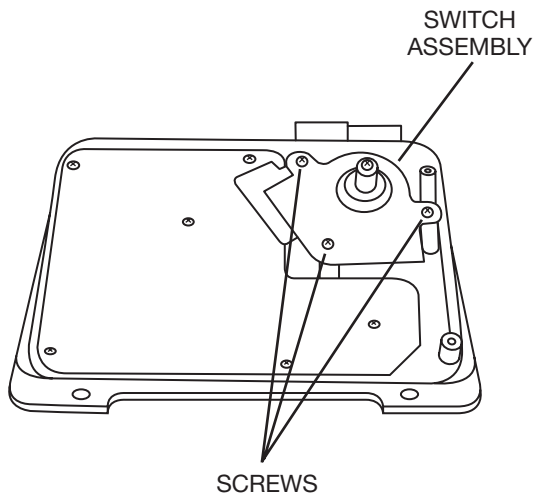

NOTE: In this illustration, the control board insulator has been removed for clarity.

2. Remove three Phillips head screws and lift the switch assembly away from the housing.
3. Noting their locations, transfer the wires to the replacement switch.
4. Installation is the reverse of removal.

Interlock Switch Assembly

REMOVE AND RE-INSTALL

The interlock switch assembly is a safety feature. The switch prevents the compactor from operating unless the door is safely closed.

1. Remove the control panel assembly from the unit (see Control Panel Assembly, Remove and Re-install).

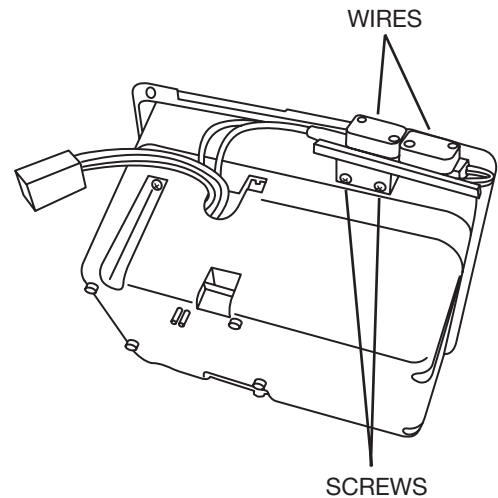

2. Noting their locations, transfer the wires to the replacement switch assembly.
3. Remove two Phillips head screws and the interlock switch assembly from the display panel.
4. Installation is the reverse of removal.

Upper Limit Switch Assembly

REMOVE AND REPLACE

This switch sets the upper travel limit for the ram mechanism.

1. Remove the back panel from the cabinet cover (see Access to Components, Remove Cabinet Cover).

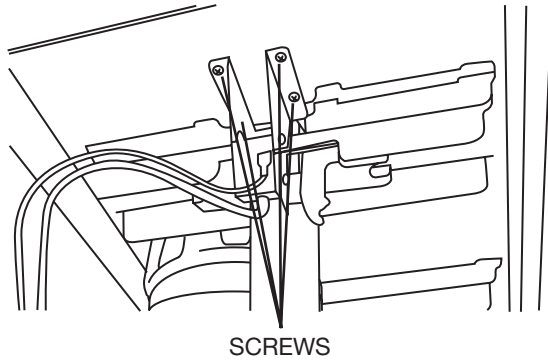

2. Remove four Phillips head screws that secure the switch assembly bracket to the top frame, and remove the switch assembly.
3. Noting their locations, transfer the wires to the replacement switch assembly.
4. Install the switch assembly and secure with four Phillips head screws.

Lower Limit Switch

REMOVE AND REPLACE

This switch sets the lower travel limit for the ram mechanism.

1. Remove the back panel from the cabinet cover (see Access to Components, Remove Cabinet Cover).

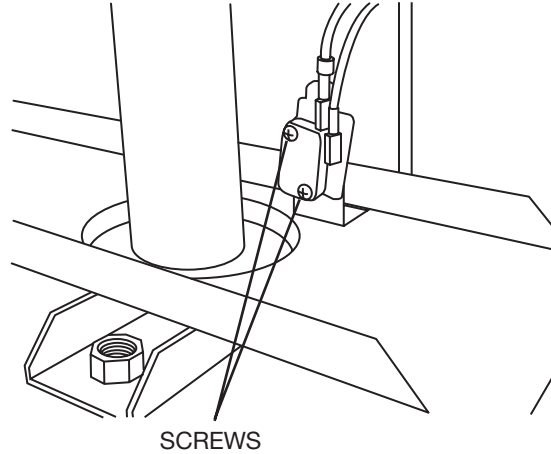

2. Remove two Phillips head screws and the switch from the center stabilizer plate.
3. Noting their locations, transfer the wires to the replacement switch.
4. Install the switch and secure with two Phillips head screws.

Motor Centrifugal Switch Assembly

REMOVE AND REPLACE

This switch reverses the motor when peak load is reached.

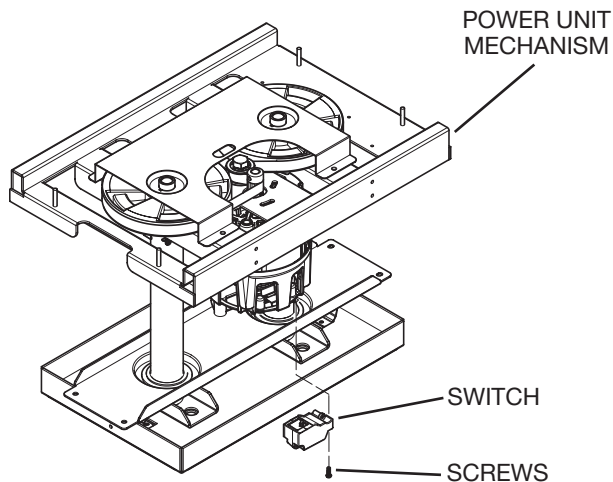

1. Remove the control panel assembly from the front of the unit (see Control Panel Assembly, Remove and Re-install).

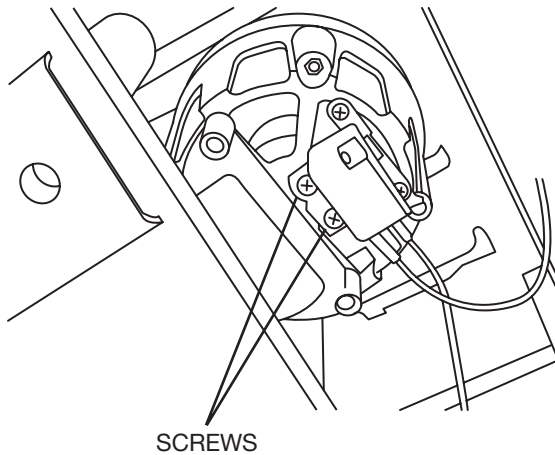

2. Remove two Phillips head screws and the switch from the bottom of the motor.
3. Noting their locations, transfer the wires to the replacement switch.
4. Install the switch and secure with two Phillips head screws.

Motor Capacitor

TEST, REMOVE AND REPLACE

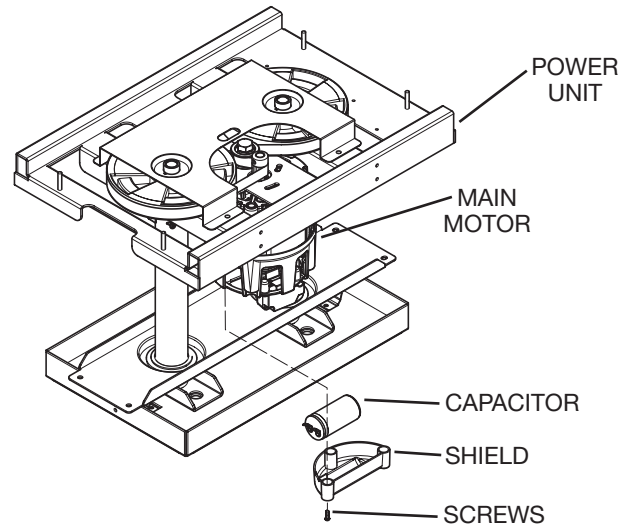

The capacitor provides power required to start the main motor and improves overall efficiency.

⚠ WARNING

Use an electrically-insulated tool to short the capacitor terminals together. This will ensure the capacitor has fully discharged and will prevent shock if any body part comes in contact with the terminals.

Before testing with a multi-meter, there are two indicators you can look for on the outside of the capacitor to see if it is bad. If you spot corrosion around the terminals or bulging electrolyte (ceramic outer material), then the capacitor is leaky and must be replaced.

To access and test the capacitor:

1. Remove the control panel assembly from the front of the compactor (see Control Panel Assembly, Remove and Re-install).

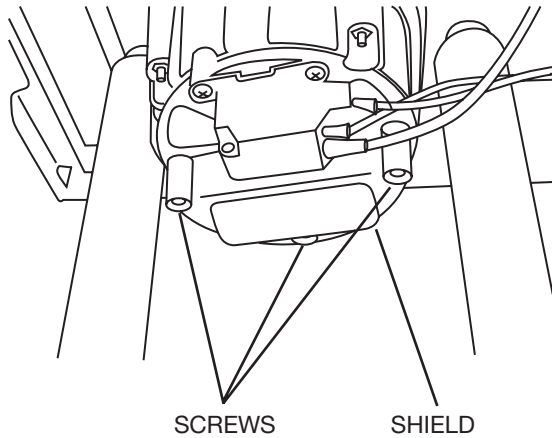

2. Locate the capacitor underneath the main motor. Remove three Phillips head screws and the shield.

3. Remove two Phillips head screws and wire leads from the capacitor.
4. Discharge the capacitor (see Warning above).
5. Use an ohmmeter or multi-meter set on the "Ohms times 1000" scale (if available) to check resistance across the wire terminals. The needle should jump toward zero ohms and quickly move back to infinity. (NOTE: Some less-sophisticated meters will only tell you if the capacitor is good or bad.)
6. If the needle does not move, if the needle reads a constant value or near zero ohms, or if the needle jumps toward zero and then moves back to constant high resistance (not infinity), replace the capacitor.
7. Installation is the reverse of removal.

NOTE: On installation, route the wires through the notches in the shield.

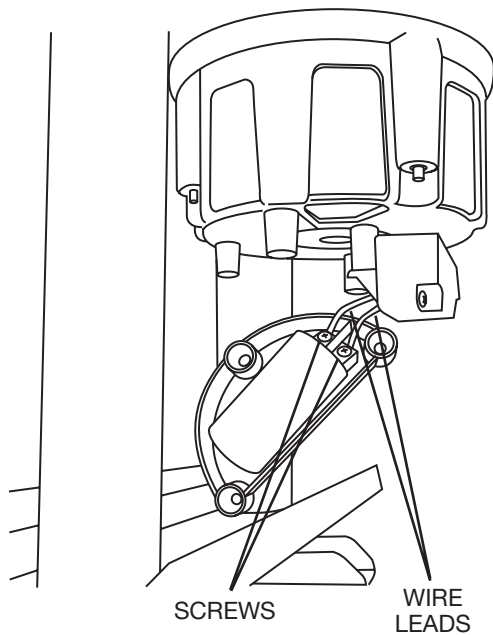

Odor Disk Gear Motor

REMOVE AND REPLACE

It is rare that this motor wears out because it operates just once a month (more if operated manually). If it should require replacement, follow the instructions below.

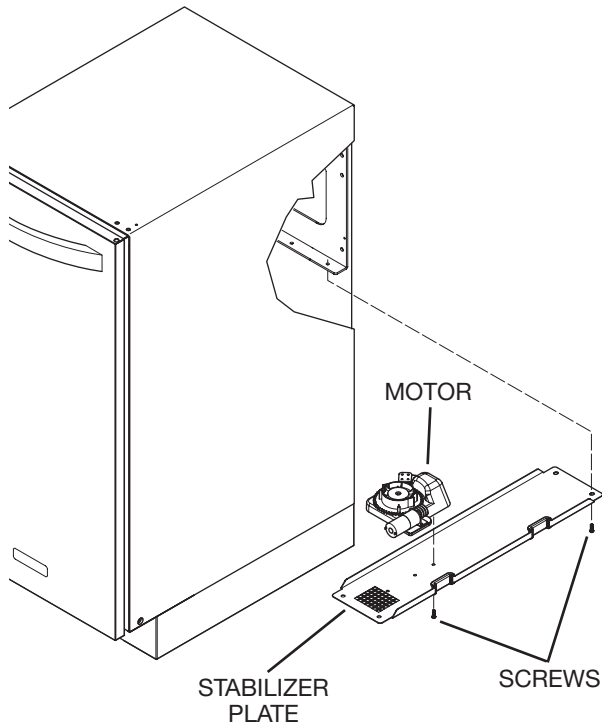

1. Before servicing this item place ram in lowest position by setting compact mode to hold. Press start button and close door. Ram will run down and stop. Disconnect power.
2. Open bucket door.
3. Remove the control panel assembly from the front of the compactor (see Control Panel Assembly, Remove and Re-install).

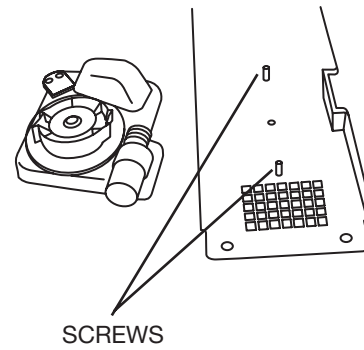

4. Remove two Phillips head screws (in above illustration, shown in place from the top) from the bottom of the right stabilizer plate and remove the odor disk gear motor.
5. Reassemble unit in reverse order.

Power Cable

REMOVE AND REPLACE

If the power cable becomes worn or frayed, replace it.

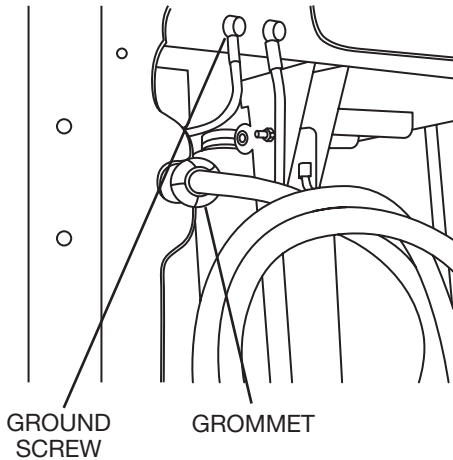

1. Remove the back panel from the compactor (see Access to Components, Remove Cabinet Cover).
2. Rotate the power cord grommet 90° and slide it out of the slot in the cabinet frame.

3. Remove the screw securing the cord's green ground wire to the frame.
4. Cut the black and white power cord wires beyond the crimp connectors and remove the cord.
5. Strip, connect and crimp the black and white wires of the replacement cord to the unit per the electrical schematic on the inside of the back panel (or in this manual).
6. Attach the cord's green ground wire to the top frame, and secure with the original screw.

WARNING

The standard color coding for safety ground wires is **GREEN**, or **GREEN WITH YELLOW STRIPES**. Ground leads are not to be used as current-carrying conductors. It is **EXTREMELY** important that the service technician re-establish all safety grounds prior to completion of service. Failure to do so will create a hazard.

7. Install the grommet on the cord and insert in cabinet frame.
8. Re-install back panel.

Troubleshooting Table

| Problem | Possible Cause | Correction |
|---|--|---|
| No power to compactor. | <ol style="list-style-type: none"> 1. Power cord not securely plugged in. 2. House fuse blown or circuit breaker tripped. | <ol style="list-style-type: none"> 1. Securely plug in cord. 2. Replace fuse or reset circuit breaker. |
| Compactor will not operate. | <ol style="list-style-type: none"> 1. Key switch in OFF or LOCK position. 2. Key switch defective. 3. Safety interlock switch not engaged when door is closed due to a: <ol style="list-style-type: none"> a. Broken actuator. b. Debris prevents door from closing. c. Damaged or deformed door. d. Gasket damaged preventing door from closing. 4. Safety interlock switch assembly defective. 5. Start switch assembly defective. 6. After repeated use, the compactor motor's automatic thermal cutout may have engaged. 7. Motor defective. 8. Defective control module. | <ol style="list-style-type: none"> 1. Turn key switch to ON position. 2. Replace key switch assembly. 3. <ol style="list-style-type: none"> a. Replace actuator. b. Remove debris and ensure door closes properly. c. Replace door. d. Replace gasket. 4. Replace interlock switch assembly. 5. Replace start switch assembly. 6. Wait a few minutes to allow unit to cool down; cutout will reset itself. 7. Replace motor or complete power mechanism. 8. Replace control board or complete display module assembly. |
| Unable to open or close trash bucket. | <ol style="list-style-type: none"> 1. Slide rail(s) damaged. 2. Trash bucket damaged or bent. 3. Debris wedged between cabinet and trash bucket. 4. Trash bag caught on ram. 5. Ram is in down position. Compact mode is set to HOLD or DELAY START is active. | <ol style="list-style-type: none"> 1. Replace rail(s). 2. Replace trash bucket assembly. 3. Remove debris. 4. Remove trash bag from ram. It may be necessary to replace the trash bag if it has been damaged. NOTE: It is recommended to fill each new trash bag completely before compacting for the first time. 5. Close door and press START to return ram to up position. |
| Trash bags pull down into trash bucket. | <ol style="list-style-type: none"> 1. Using trash bags designed for another manufacturer's compactor. 2. Improper installation of trash bag. | <ol style="list-style-type: none"> 1. Use Broan replacement trash bags. 2. Install trash bag correctly. Refer to trash compactor use and care guide for installation instructions. |

Troubleshooting Table (Continued)

| Problem | Possible Cause | Correction |
|--|--|---|
| Noticeable odor coming from trash compactor. | <ol style="list-style-type: none"> 1. Active section of deodorant disk has expired. 2. Entire deodorant disk has expired. 3. Odor causing trash is trapped outside of the trash bucket. 4. Damaged door gasket. | <ol style="list-style-type: none"> 1. Advance deodorant disk to next section. 2. Replace deodorant disk. 3. Clean or remove odor causing trash. Check behind the trash bucket and on top of the ram. NOTE: It is recommended to place folded sheets of newspaper on top of the trash when compacting messy food waste or items that may shatter to keep the trash compactor compartment clean and in good working order. 4. Replace door gasket. |
| Deodorant disk auto advance feature does not function. | <ol style="list-style-type: none"> 1. Auto advance motor is defective. 2. Defective control board. 3. Defective power board. | <ol style="list-style-type: none"> 1. Replace auto advance motor assembly. 2. Replace control board or complete display module assembly. 3. Replace power board or complete display module assembly. |
| During compaction cycle the motor runs but the ram doesn't move. | Drive belt is damaged. | Replace drive belt. |
| Compactor does not compact cans or bottles. Compaction force appears weak. | <ol style="list-style-type: none"> 1. Insufficient amount of trash in trash bucket. 2. Bottles or cans are arranged too uniformly. 3. Lack of lubrication on moving components. 4. Compaction plate not installed. | <ol style="list-style-type: none"> 1. Ram does not travel to bottom of trash bucket. Ensure trash bucket is at least half full before compacting. Compaction results will improve as more trash is added. 2. Bottles and cans should be placed randomly in center of drawer. Cans and bottles neatly arranged are capable of supporting a tremendous amount of pressure. 3. Inspect power mechanism and regrease components on mechanism as necessary. NOTE: It is recommended to use high quality wheel bearing grease. 4. Install compaction plate. |

Troubleshooting Table (Continued)

| Problem | Possible Cause | Correction |
|--|--|--|
| Compactor stops during operation. | <ol style="list-style-type: none"> 1. Uneven load may cause trash bucket to shift forward opening the door. 2. Uneven load may cause ram to wedge in trash basket. | <ol style="list-style-type: none"> 1. Gently push the door closed until the door actuator engages the interlock switch. This will activate the ram until it returns to the up position. Open trash bucket and reposition any objects that may be causing the uneven load. 2. Open and close door to activate the ram to the up position. If the ram is still stuck, it may be necessary to remove cabinet and reverse screw assemblies manually. |
| Compaction cycle repeats without pressing START. | Control board defective. | Replace control board or complete display module assembly. |
| After closing the door and pressing START, ram reverses direction repeatedly for 3 seconds and shuts off. | <ol style="list-style-type: none"> 1. Lower limit switch defective. 2. Centrifugal switch defective. | <ol style="list-style-type: none"> 1. Replace lower limit switch. 2. Replace centrifugal switch assembly. |
| Ram runs down for 3 seconds and motor stops. | <ol style="list-style-type: none"> 1. Defective upper limit switch assembly. 2. Defective centrifugal switch. | <ol style="list-style-type: none"> 1. Replace upper limit switch assembly. 2. Replace centrifugal switch assembly. |
| Motor hums after ram returns to the up position. | Defective upper limit switch assembly. | Replace upper limit switch assembly. |
| Ram continues to run with the door open. | Defective interlock switch. | Replace interlock switch assembly. |
| During NORMAL compact mode, ram runs down and doesn't return up. Motor hums after reaching the bottom position. | Defective upper limit switch assembly. | Replace upper limit switch assembly. |
| During NORMAL compact mode, ram runs down and stops (operates as it would in HOLD compact mode). | Control board defective. | Replace control board or complete display module assembly. |
| During HOLD compact mode, ram runs down and up (operates as it would in NORMAL compact mode). | Defective centrifugal switch. | Replace centrifugal switch assembly. |
| <p>Trash compactor noise level increases during operation.</p> <p>NOTE: Due to the number of moving components, it is expected that operating noise may increase over the life of the product.</p> | <ol style="list-style-type: none"> 1. Worn or damaged drive components. 2. Lack of lubrication on moving components. | <ol style="list-style-type: none"> 1. Inspect power mechanism and replace damaged or worn components. 2. Inspect power mechanism and regrease components on mechanism as necessary. <i>It is recommended to use high quality wheel bearing grease.</i> |

Specifications Table

**BROAN 15-INCH WIDE, AUTOMATIC TRASH COMPACTOR MODELS:
15XEW, 15XEBL, 15XESS, 15XESSA, 15XEW, 15XETT**

| Volts | Hz | Amps | Capacity | Compactor | Weight | Dimensions |
|-------|----|------|----------------------------------|---------------------|------------------------|---|
| 120 | 60 | 5.0 | 1.55 ft. ³ 30 lbs. | 3000 lbs. 6 to 1 | 165 lbs. (packaged) | 34-1/8" H (min.) 14-7/8" W 21-1/2" D* |

*Model 15XESSA = 22-1/4" D

Wiring Schematic

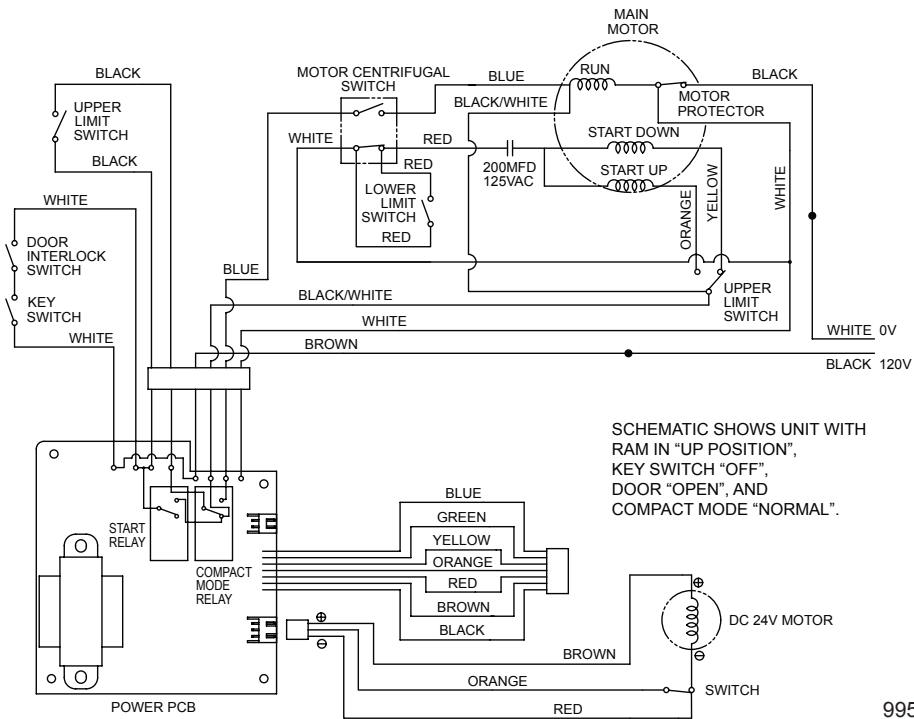
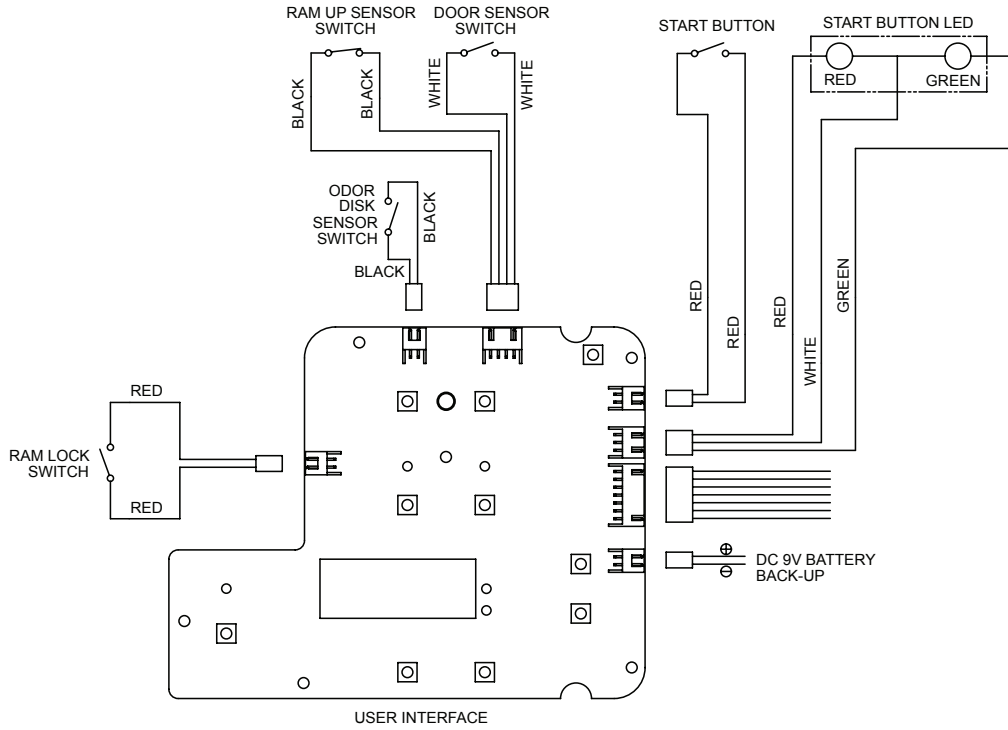

99526828B

Drawing and Parts List – Doors

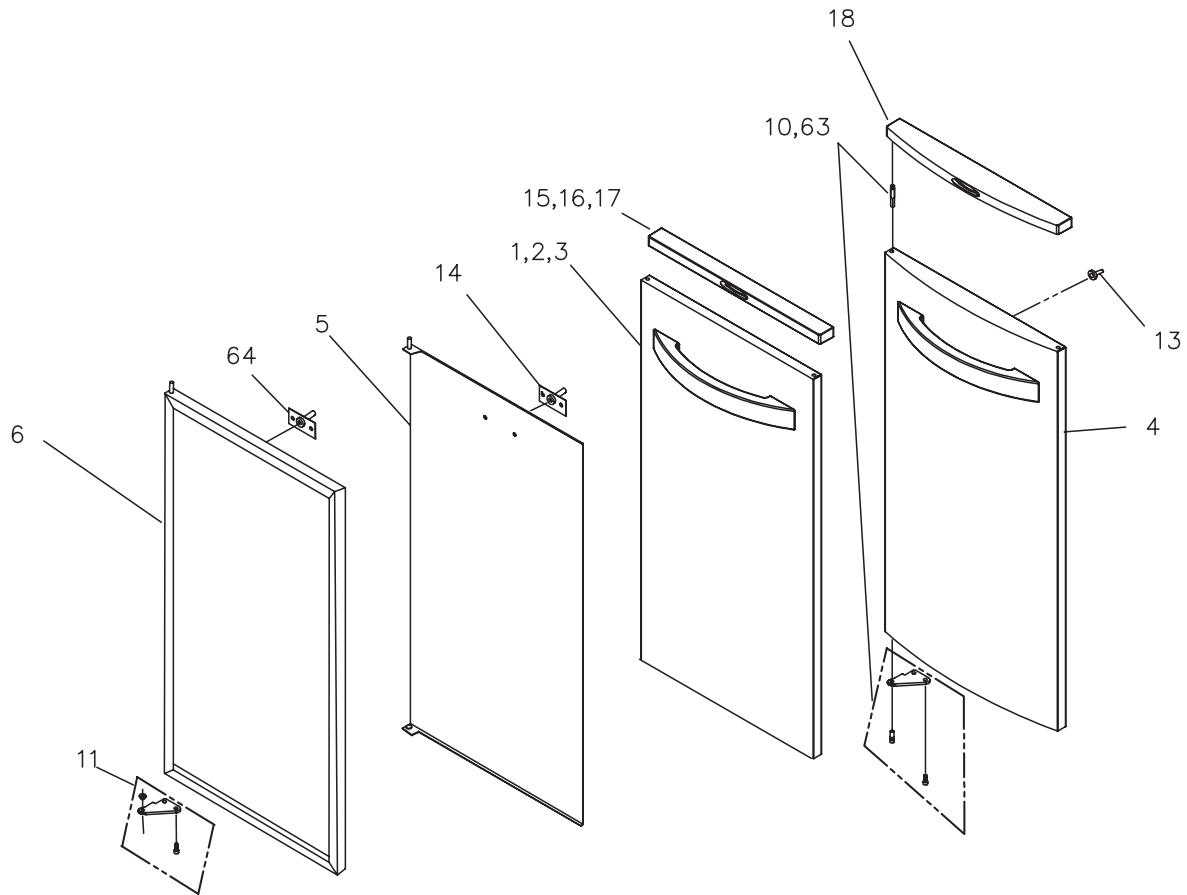

| Item | Part No. | Description |
|------|-----------|--------------------------|
| 1 | S99526834 | Door Assembly-Flat White |
| 2 | S99526835 | Door Assembly-Flat Black |
| 3 | S99526836 | Door Assembly-Flat SS |
| 4 | S99526837 | Door Assembly-Arch SS |
| 5 | S99526838 | Door-Wood |
| 6 | S99526839 | Door-Tile |
| 10 | S99526843 | Door Hardware-White/SS |
| 11 | S99526844 | Door Hardware-Wood/Tile |

| Item | Part No. | Description |
|------|-----------|--------------------------------|
| 13 | S99526846 | Safety Interlock Actuator |
| 14 | S99526847 | Safety Interlock Actuator-Wood |
| 15 | S99526848 | Top Trim Cover Assy-White |
| 16 | S99526849 | Top Trim Cover Assy-Black |
| 17 | S99526850 | Top Trim Cover Assy-SS |
| 18 | S99526851 | Top Trim Cover Assy-Arch-SS |
| 63 | S99526966 | Door Hardware-Black |
| 64 | S99526967 | Interlock Actuator-Tile |

Drawing and Parts List – Cabinet

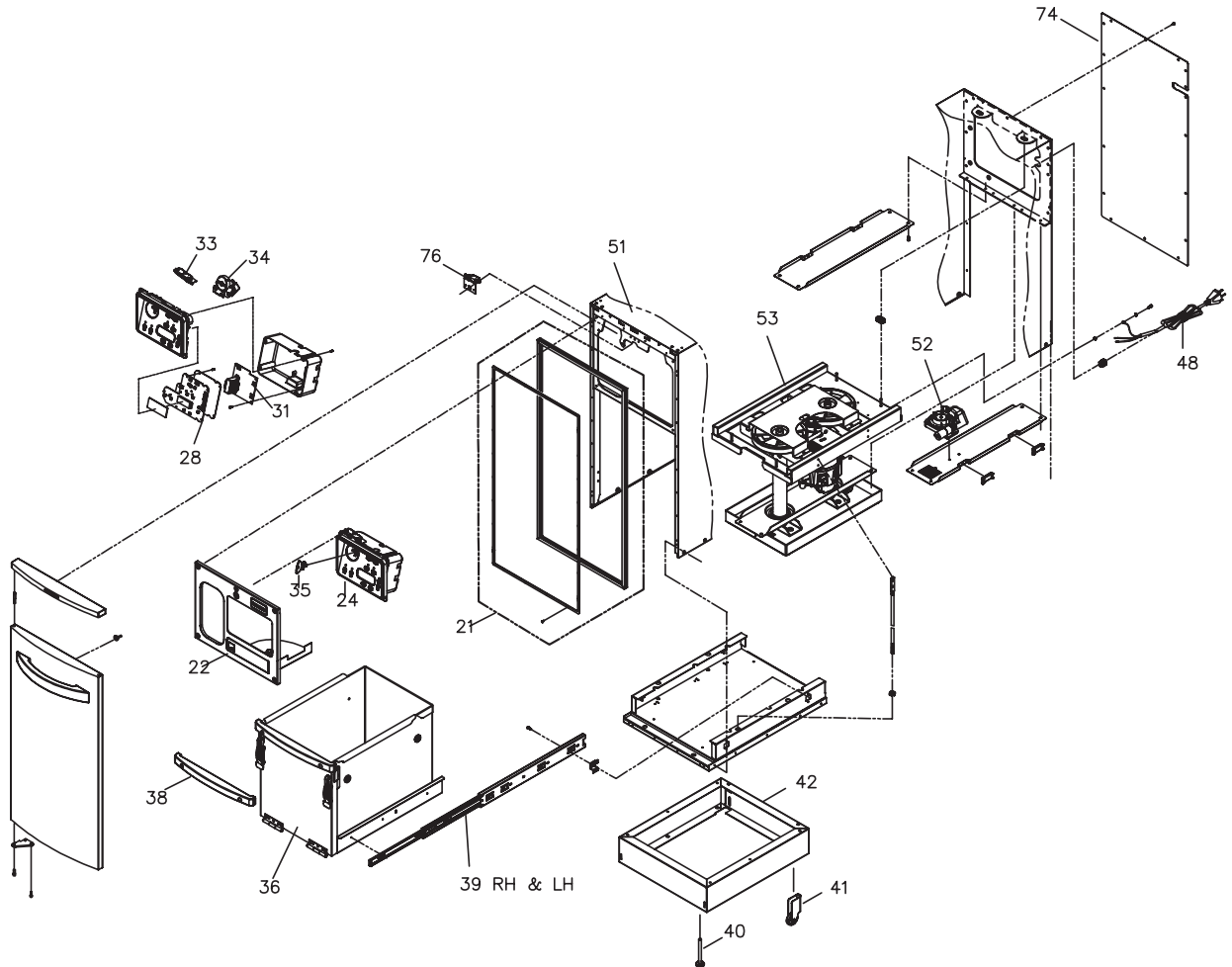

| Item | Part No. | Description |
|------|-----------|-----------------------------|
| 21 | S99526854 | Door Gasket Assembly |
| 22 | S99526855 | Control Panel-Auto Advance |
| 24 | S99526857 | Display Module |
| 28 | S99526861 | PCB Assembly |
| 31 | S99526864 | AC/DC Assembly |
| 33 | S99526866 | SRV-Safety Interlock Switch |
| 34 | S99526867 | Key Switch Electronic Model |
| 35 | S99526868 | Key |
| 36 | S99526869 | Bucket Assembly |
| 38 | S99526871 | Bucket Handle |
| 39 | S99526872 | Bucket Slide Assembly |

| Item | Part No. | Description |
|------|-----------|--------------------------------|
| 40 | S99526873 | Leveling Leg |
| 41 | S99526874 | Leveling Wheel Assembly |
| 42 | S99526875 | Cabinet Stand/Base |
| 48 | S99526881 | Power Cord |
| 51 | S99526884 | Cabinet |
| 52 | S99526885 | Gear Motor-Odor Disk Advance |
| 53 | S99526886 | Power Unit Mech |
| 74 | S99527026 | Cabinet Back Panel |
| 76 | S99527074 | Start Switch Elite |
| 77 | S99527094 | Parts Bag Assembly (Not Shown) |

Drawing and Parts List – Mechanism

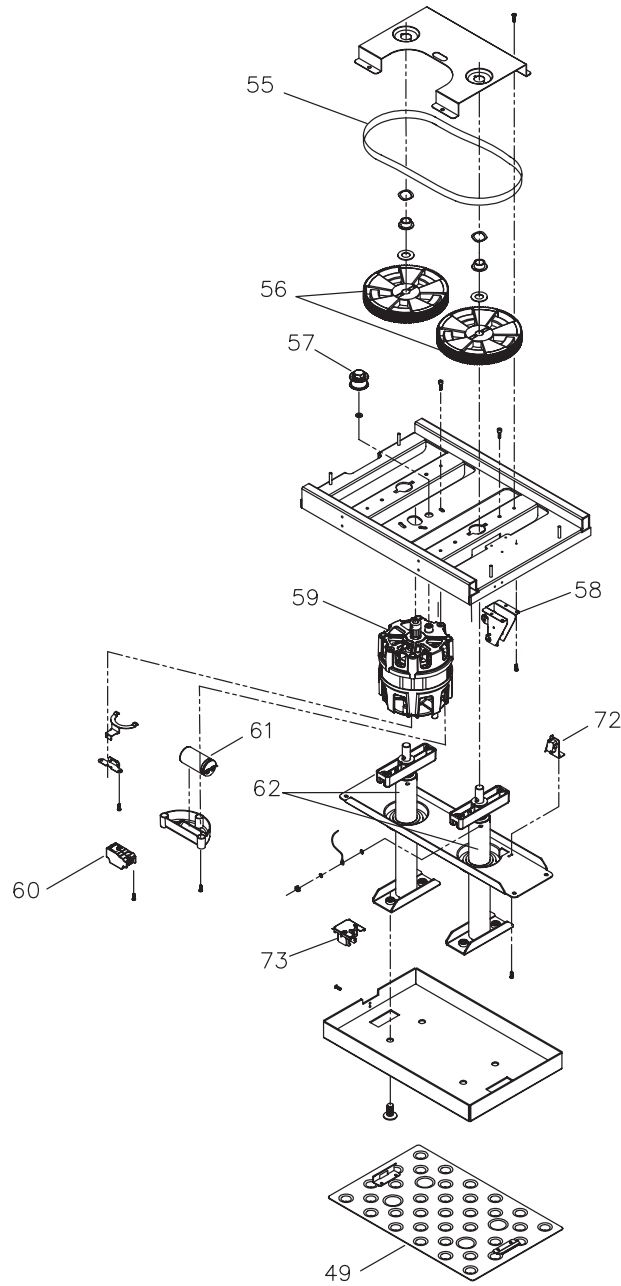

| Item | Part No. | Description |
|------|-----------|-------------------------|
| 49 | S99526882 | Compaction Plate-SS |
| 55 | S99526888 | Drive Belt |
| 56 | S99526889 | Drive Wheel |
| 57 | S99526890 | Idler Wheel |
| 58 | S99526891 | Upper Limit Switch Assy |
| 59 | S99526892 | Main Motor |

| Item | Part No. | Description |
|------|-----------|-----------------------------|
| 60 | S99526893 | Centrifugal Switch Assembly |
| 61 | S99526894 | Motor Capacitor |
| 62 | S99526895 | Ram Screw Assembly |
| 72 | S99527019 | Lower Limit Switch |
| 73 | S99527020 | Latch Assy-Compaction Plate |

