

OWNER'S MANUAL

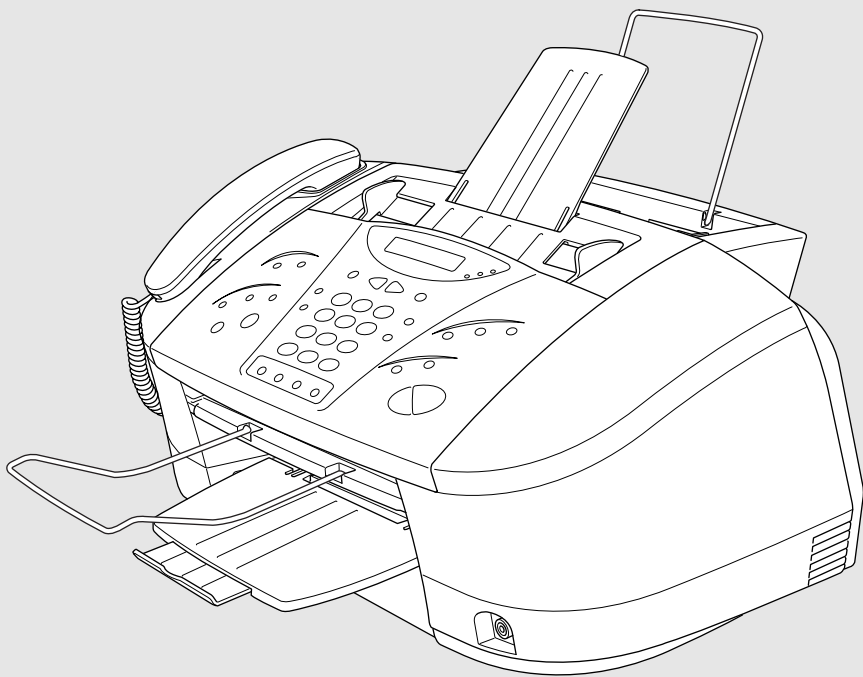

MFC-830^{CE}
MFC-840

brother.

AVAILABLE MODELS FOR EACH COUNTRY

U.K.	
Ireland	
Others	

THIS EQUIPMENT IS DESIGNED TO WORK WITH A TWO WIRE ANALOGUE PSTN LINE FITTED WITH THE APPROPRIATE CONNECTOR.

APPROVAL INFORMATION

Brother advises that this product may not function correctly in a country other than which it was originally purchased, and does not offer any warranty in the event that this product is used on public telecommunication lines in another country.

Using This Manual

Thank you for purchasing a Brother multifunction centre (MFC).

This MFC has been designed to be simple to use, with LCD screen prompts to guide you through functions. However, you can use your MFC to its fullest potential by taking a few minutes to read this manual.



Additionally, your MFC has a Help Key. Press **Shift** and **Receive Mode** to print a list of basic operational steps and functions.

Finding Information

All chapter headings and subheadings are listed in the Table of Contents. You will also be able to find information about a specific feature or function by checking the Index at the back of this manual. Also, throughout this manual, you will see special symbols alerting you to important information, cross-references, and warnings. Illustrations of some screen displays also help you choose the correct key-presses.

Symbols Used In This Manual



Note or additional information.



The MFC may be damaged or may not work correctly if this is not observed.



Caution please take care with sections marked with this symbol.

User-Friendly Programming

We have designed your Multi-Function Centre with on-screen programming. User-friendly programming helps you take full advantage of all the functions your MFC has to offer. *See Using This Manual.*

Since your programming is done on the LCD, we have created step-by-step on-screen prompts to help you. All you need to do is follow the prompts as they guide you through the function menu selections, programming options and settings.

A complete list of the function selections, options, and settings that are available is provided in the appendix of this manual. (See *Menu Selection Table* in Chapter 23.)

Menu Mode

After pressing **Menu** key the following options are available.

Then press **1** for Fax Menu—**OR**—press **2** for Printer Menu—**OR**—press **3** for Copy Menu—**OR**—press **4** for Video Menu—**OR**—(For MFC-840 only) press **5** for PhotoCapture Centre™ Menu.

When you enter the Menu Mode, your MFC displays a list of Level One Menus from which you can choose. These menu options appear one after the other on the display. Select an option by pressing **Set** when the option appears on the LCD.

You can “scroll” more quickly through options by pressing **▶**. When the screen displays your selection, press **Set**. (Use **◀** to scroll backward if you passed your choice or to save key strokes. Both arrow keys show all options, in the opposite order.)

When you finish selection, the screen displays **ACCEPTED**.



If you want to exit the **Menu Mode**, press **Stop**.

Alternating Displays

The LCD sometimes alternates between the currently selected option, and a help message giving brief instructions about how to proceed. The display you'll probably see most often is shown below, showing you that when you place a document in the feeder, you can either dial a number to send it as a fax or press the **Mono Copy** or **Colour Copy** key to make a copy of the document.



Table of Contents

PREPARATION AND SIMPLE USE

Using This Manual

User-Friendly Programming

Table of Contents	iv
-------------------------	----

Preparation and Simple Use Guide

Advice for Preparation and Simple Use Guide	8
Control Panel Overview	15

BASIC USE

Chapter 1 Setup

Custom Settings	18
Storing Numbers for Easy Dialling	19

Chapter 2 Sending a Fax

Scanning Adjustment	21
Sending Operation	21

Chapter 3 Receiving a Fax

Receive Mode Settings	24
Receiving a Fax	25

Chapter 4 Telephone (Voice) Operation

Making Voice Calls	29
--------------------------	----

Chapter 5 Printing Reports

Types of Reports	32
Transmission Report	32
Setting Reports	33

ADVANCED USE

Chapter 6 Advanced Sending

Advanced Operations	34
---------------------------	----

Chapter 7 Advanced Receiving

Operation from an External or Extension Telephone	42
Telephone Services	43

Chapter 8 Polling

Polling Receive	44
Polling Transmit (Not Available for Colour Fax)	46

Chapter 9	Remote Fax Options (Not Available for Colour Fax)	
	Fax Forwarding	47
	Remote Retrieval	48

COPIER

Chapter 10	Making Copies	
	Basic Copy Operations	52
	Temporary Copy Setting	53
	Copy Quality – Default Settings	56
	Legal Limitations	59

VIDEO PRINTING

Chapter 11	Walk-Up Video Printing	
	Getting Started	60
	Colour Video Printing	61
	Black & White Video Printing	61
	Temporary Video Print Setting	61
	Changing Default Settings	63
Chapter 12	Walk-Up Photo Capture Centre™ (For MFC-840 only)	
	General Description	67
	Getting Started	67
	Changing Default Settings	72

PRINTER/SCANNER

Chapter 13	Setting Up the MFC and PC to Work Together	
	Using the Brother Machine with Your PC	76
	Before You Install Multi-Function Link® Pro	76
	Using a bi-directional IEEE-1284 compliant parallel cable to Connect the MFC to the PC (Using Windows® 95, 98, 98SE, Windows NT® Workstation Version 4.0 and Windows® 2000 Professional)	77
	Using a USB Cable to Connect the MFC to the PC (Using Windows® 98, 98SE and Windows® 2000 Professional Only)	90
	Installing the Brother Software	100
Chapter 14	Using the MFC as a Printer	
	Features	102
	Printer Driver	102
	Choosing the Right Kind of Paper	103
	Multi-purpose Sheet Feeder	103
	Simultaneous Printing/Fax	104
	Printer Operation Keys	104

Chapter 15	Printer Driver Settings	
	Using the Brother MFC-830/MFC-840 Printer Driver	105
	The Paper Tab.....	105
	The Quality/Colour Tab	108
Chapter 16	Using the Windows®-Based Brother Control Centre (For Windows® 95/98/98SE and NT® 4.0)	
	Brother Control Centre	112
	Using the Scan Keys with PC Windows	113
	Using the Control Panel Keys	114
	Brother Control Centre Features	115
	Scan to File	118
	Send Scan to E-mail	119
	Send Scan to Word Processor.....	121
	User Defined Button.....	122
	Copy/Two on One Copy.....	123
Chapter 17	Using ScanSoft™ PaperPort® for Brother/TextBridge®	
	Using ScanSoft™ PaperPort® and TextBridge®	124
	Scanning a Document.....	127
	Video Capture from the PC	131
Chapter 18	Using Multi-Function Link® Pro Software	
	Introduction	134
	MFC Remote Setup	135
Chapter 19	Using the PhotoCapture Centre™ from Your PC (MFC-840 only)	
	Introduction	136
Chapter 20	Using the Brother MFC with a New Power Macintosh® G3, G4 or iMac™/iBook™	
	Set up Your USB Equipped Apple® Macintosh® G3,G4 or iMac™ with Mac OS 8.5/8.51/8.6/9.0.....	137
	Installing the Brother Printer and Scanner Drivers	137
	Using Brother Printer Driver with your Apple® Macintosh®	138
	Using Brother TWAIN Scanner Driver with Your Apple® Macintosh®	140

MAINTENANCE

Chapter 21 Troubleshooting and Maintenance

Error Messages.....	145
Clearing Jams.....	146
Difficulty with Operation.....	149
How to Improve Print Quality	153
Packing and Shipping the MFC	155
Regular Maintenance	157

IMPORTANT INFORMATION

Chapter 22 Important Safety Information

Important Safety Instructions.....	161
IMPORTANT-For Your Safety	162

APPENDIX

Chapter 23 Specifications

Fax Specifications.....	163
Printer Specifications	164
Compilation and Publication Notice.....	165
Trademarks	165
Brother Paper	166
Entering Text	169
Menu Selection Table	170
About Fax Machines	174
Glossary	175
Index	178

Preparation and Simple Use Guide

Steps to prepare and use the MFC simply

Follow the steps below to prepare and use the MFC simply.

However, before you perform these steps, see Important Safety Information, Precaution, and Advice for Preparation and Simple Use Guide.

If you need further information, refer to BASIC USE or ADVANCED USE.

1 Make sure you have the items shown below.

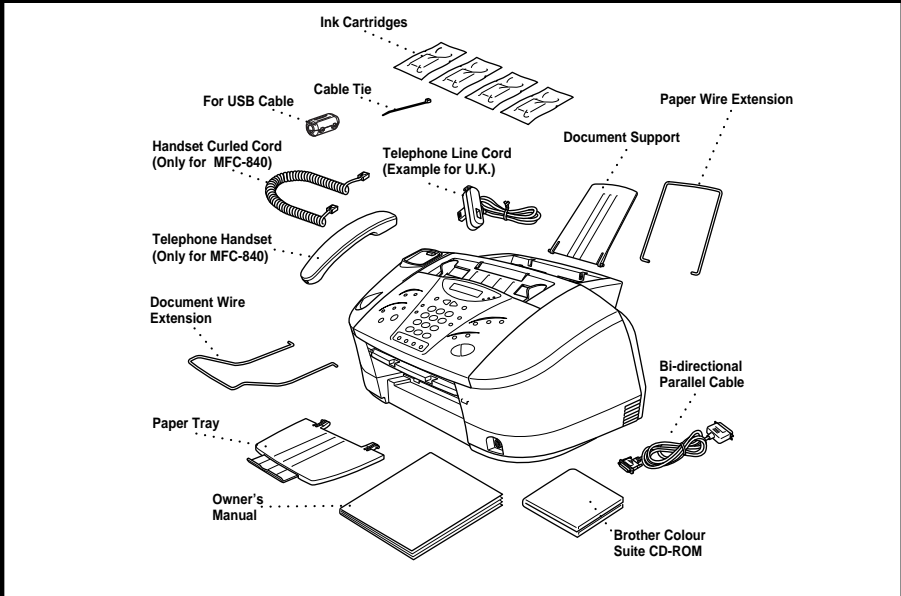

2 Connect the power cord and telephone line cord (and handset for MFC-840).

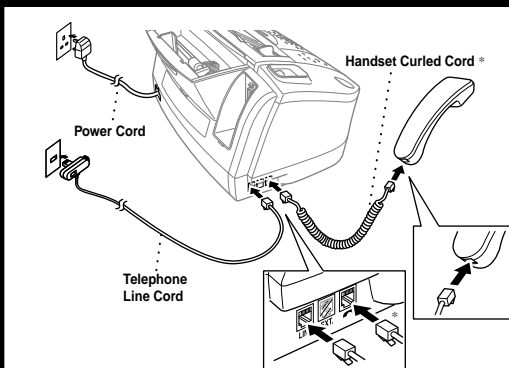

When you connect the power, the screen alternately displays



(See *Connecting the Power Cord* in this Chapter.)

* ... Only for MFC-840 (Example for the U.K.)

3 Attach paper wire extension, document support, paper tray and document wire extension.

- ① Attach the paper wire extension to the multi-purpose sheet feeder.

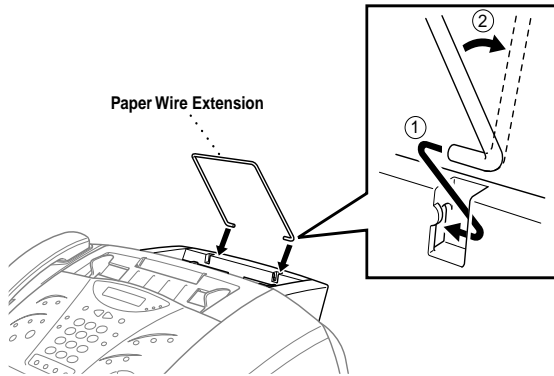

- ② Attach the plastic document support

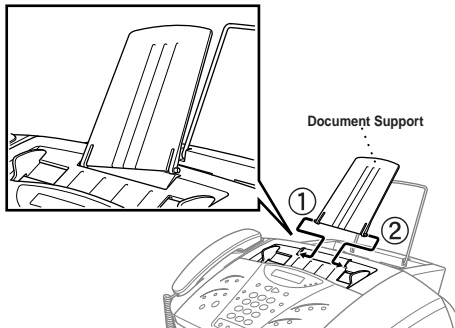

- ③ Attach the paper tray to the paper output slot, and pull out the plastic extension.



Please attach the paper tray to prevent paper jams and maintain print quality.

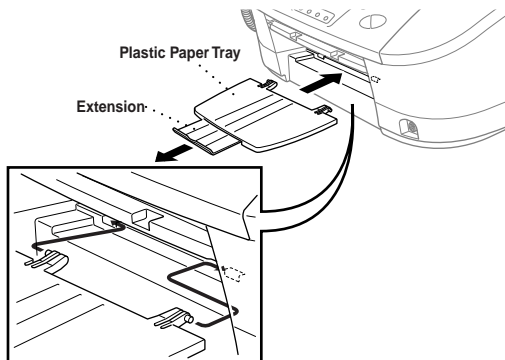

- ④ Attach the document wire extension.

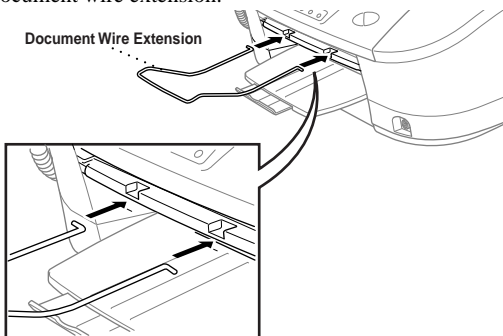

4 Load paper in the paper cassette

- ① Fan the paper well. Load the paper. Gently insert the paper. Make sure the print side is toward you and the paper level is stacked below the paper guide line.

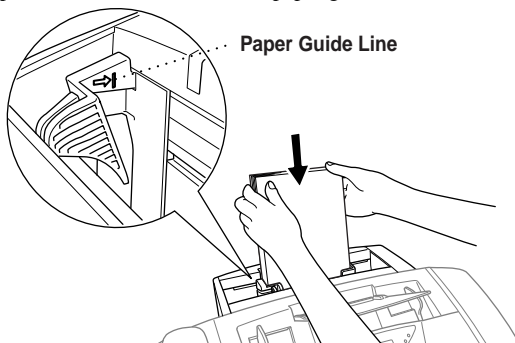

- ② Adjust the guide to fit the paper width.

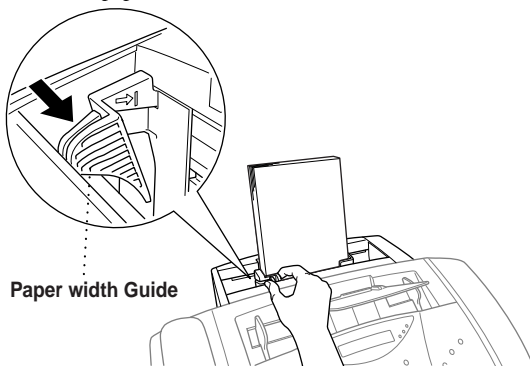

5 Install the ink cartridges.

- ① Make sure that the power is on. The screen alternately displays



- ② Open the control panel cover by pulling it toward you (①), then lift the top cover toward the back (②). After a few seconds, the print head will move left to its replacement position.

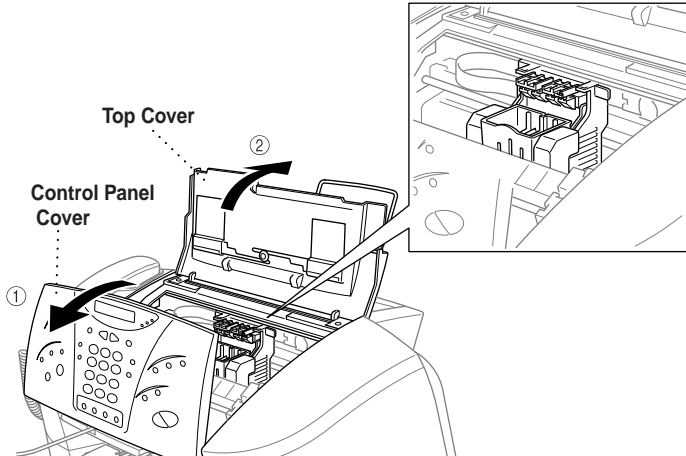

- ③ Remove the yellow shipping cover by pulling it toward you and lifting it up and out.



The bottom of the yellow shipping cover may have a small amount of wet ink so it should be wiped after removal.

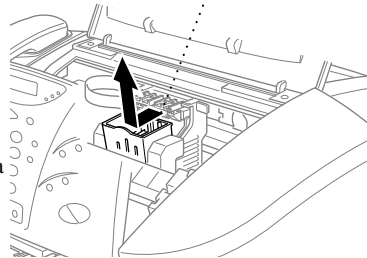

We recommend that you install the ink cartridges from left to right in this order: Black, Yellow, Cyan, Magenta.

- ④ Open the Black ink cartridge bag and remove the ink cartridge.

- ⑤ Carefully remove the sealing tape from the side of the ink cartridge. Be sure to peel the tape in the direction away from you.

Important

To prevent spilling ink and staining your hands and clothing, peel the sealing tape gently and slowly. Do not touch the ink opening on the cartridge or the removed tape.

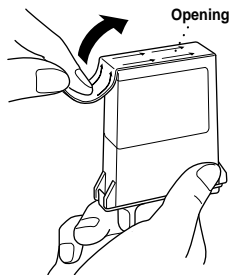

- ⑥ Each colour has its own correct position. Match the markings of the colour indicators on the cartridge holder as a guide. Then, gently insert the Black ink cartridge by tilting it toward you and then pressing it backward until it clicks into place.

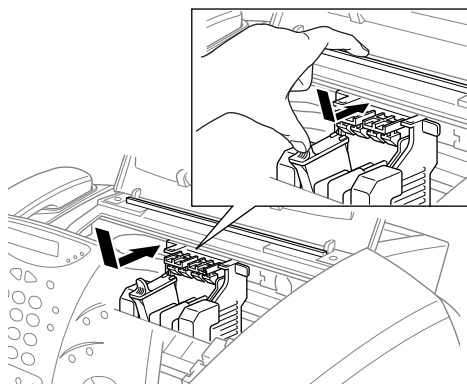

- ⑦ Repeat Steps 4 – 6 to install each colour ink cartridge.
- ⑧ After installing all ink cartridges, close the top cover and control panel cover until they click into place. Your MFC enters a “head cleaning” cycle for approximately 6 minutes. The dot counters for each colour are initialized and the machine goes online ready for printing.



Make sure the paper is loaded in the multi-purpose sheet feeder.

The LCD displays **CLEANING BLACK**.

After the cleaning cycle is finished, the LCD shows **THEN PRESS START**.

- ⑨ Press **Start** within one minute. The MFC starts printing the Test Sheet. (Only during initial ink cartridge installation) The LCD shows:

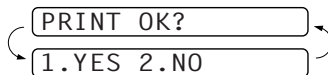

- ⑩ Check the print quality of the test sheet. If it is not good, clean the print head again by pressing **2**. The screen will ask you if the print quality is OK for each colour. Select **NO** for the colour(s) which have not printed correctly. After cleaning is finished, press **Start**. The MFC starts printing Test Sheet No. 2.
- ⑪ Adjust the Vertical Alignment by following the instructions printed on the Test Print page.



- If ink gets in your eyes, flush them with water immediately and seek medical attention if required.
- DO NOT remove ink cartridges if you do not need to replace them. If you do so, it may reduce the ink quantity and the MFC will not know the quantity of ink left in the cartridge.
- DO NOT shake the ink cartridges. If you do so, the ink may spill when you take off the sealing tape. If ink stains your body or clothing, wash with soap or detergent immediately.
- If you install an ink cartridge in the wrong colour position, you must clean the print head several times after correcting the cartridge installation and before you start printing because the colours were mixed.
- Once you open an ink cartridge, install it in the MFC and use it up within six months of installation. Use unopened ink cartridge by the expiry date printed on the box.
- DO NOT refill the ink cartridges. Attempting to use refilled cartridges may cause damage to the print head and will void your product warranty.

If the **INK EMPTY XXXX** error message is on the screen display after you have installed the ink cartridges, check and make sure that the ink cartridges are installed correctly.

6 Set the date and time

- ① Press **Menu, 1, 1, 2.**
- ② Enter the last two digits of the year, and press **Set.** "01" is registered as 2001 in the machine.
YEAR : XX
- ③ Enter two digits for the month and press **Set.**
MONTH : XX
- ④ Enter two digits for the day and press **Set.**
DAY : XX
- ⑤ Enter the time in 24 hour format and press **Set.**
TIME : XX : XX
- ⑥ Press **Stop** to exit. (See *Setting the Date and Time* in this Chapter.)

7 Set the station ID

- ① Press **Menu, 1, 1, 3.**
- ② Enter your fax number (up to 20 digits) and press **Set.**
FAX :
- ③ Enter your telephone number (up to 20 digits) and press **Set.**
TEL :
- ④ Enter your name (up to 20 characters) using the dial pad and the chart.
To enter a space press **▶**.
NAME :
- ⑤ Press **Set.**
- ⑥ Press **Stop.**
(See *Setting the Station ID* in this Chapter.)

Press Key	once	twice	three times	four times	five times
2	A	B	C	2	A
3	D	E	F	3	D
4	G	H	I	4	G
5	J	K	L	5	J
6	M	N	O	6	M
7	P	Q	R	7	P
8	T	U	V	8	T
9	W	X	Y	9	W

8 Select the Receive mode for receiving a fax or voice call.

Manual

You must answer all calls yourself. If you hear fax tones, press **Start**, then hang up.

Fax only

The MFC automatically answers every call as a fax call. You cannot receive a voice call, but you can dial out and make a voice call.

Fax/Tel

The MFC automatically answers every call. If the call is a fax, it prints the fax. If the call is not a fax, it signals you to pick up the call.

TAD

This is the only setting in which you can use an **external** answering machine. Your telephone answering device is connected to your machine, and answers every call. Once the external telephone answering device (TAD) answers, the machine listens for fax tones. If it detects fax tones, Fax messages are received.

The TAD setting works only with an external telephone answering device (TAD). Ring Delay and F/T Ring Time do not work in this setting. (See *Receiving a Fax* in Chapter 3.)

9 Manual Dialling

- ① Pick up the handset of an external telephone (for MFC-830)—**OR**—pick up the handset of the MFC (for MFC-840).
- ② When you hear a dial tone, dial the number, using the dial pad.
- ③ To hang up, replace the handset.

10 Sending a fax automatically.

- ① Insert the document face down in the feeder.
- ② Enter the fax number you want to call.
- ③ Press **Start**.

IMPORTANT : Do not pick up the handset.

11 Making a single copy

- ① Insert the document face down in the feeder.
- ② Press **Mono Copy** or **Colour Copy** once, and then press the same key again.
- ③ To stop copying, press **Stop**. Press **Stop** again to release the original document.
(See *Making Copies* in Chapter 10.)

12 Multiple Copies

- ① Insert the document face down in the feeder.
- ② Press **Mono Copy** or **Colour Copy**.
- ③ Using the dial pad, enter the number of copies you want.
For example, press **3, 8** for 38 copies.
- ④ Press **Mono Copy** or **Colour Copy** again.



To sort the copies, use Option key.
(See *Using the Options Key* in Chapter 10.)

13 Set up the MFC and your PC to Work Together.

- For Windows[®]95, 98, 98SE, WindowsNT[®] Workstation Version4.0 and Windows2000 Professional users, please see Chapter 13.
- For New Power Macintosh[®], G3, G4 or iMac[™]/iBook[™] users, please see Chapter 20.

Advice for Preparation and Simple Use Guide

Packing

Whenever you transport the MFC, use the packing materials that came with your MFC and pack the MFC correctly.

Choosing a Location

Place your MFC on a flat, stable surface, such as a desk. Select a place that is free of vibration and shocks. Locate the MFC near a telephone socket and a standard, earthed electrical socket. Choose a location where the temperature remains between 10°C and 32°C (50° – 90°F).

Avoid placing your MFC where it may be knocked. Do not place near heaters, air conditioners, water, chemicals or refrigerators. Do not expose the MFC to direct sunlight, excessive heat, moisture or dust. Do not connect your MFC to electrical outlets controlled by wall switches or automatic timers as disruption of power can wipe out information in the unit's memory. Do not connect your MFC to electrical outlets on the same circuit as large appliances or other equipment that might disrupt the power supply. Avoid interference sources, such as speakers or the base units of cordless phones.



Keep the MFC out of strong light such as direct sunlight.



- **Never touch telephone wires or terminals that are not insulated unless the telephone line has been disconnected at the network interface.**
- **Use caution when installing or modifying telephone lines.**

Connecting the Power Cord



- **Operating the MFC before you install the ink cartridges will permanently damage the print head.**
- **The MFC must be fitted with an earthed plug.**
- **Since the MFC is earthed via the mains plug, you can protect yourself from potentially hazardous electrical conditions on the telephone network by keeping the power to your MFC on when you connect it to a telephone line. Similarly, you can protect yourself when you want to move your MFC, by disconnecting the telephone line first, and then the power cord.**



If you need to remove the moulded mains plug in order to fit an appropriate type, you must discard the moulded plug immediately having cut it off, in order that it is not inadvertently inserted into a live socket, thus presenting a shock hazard. The wires in the mains lead of this appliance are coloured in accordance with the following code.

- **Green-and-yellow:** Earth
- **Blue:** Neutral
- **Brown:** Live

As the wires in the mains lead of this apparatus may not correspond with the coloured markings identifying the terminals in your plug, proceed as follows:

The wire which is coloured green-and-yellow must be connected to the terminal in the plug which is marked by the letter “E” or by the safety earth symbol \perp or coloured green or green-and-yellow.

The wire which is coloured blue must be connected to the terminal which is marked with the letter “N” or coloured black.

The wire which is coloured brown must be connected to the terminal which is marked with the letter “L” or coloured red.

Memory Storage

In the event of a power failure, all settings in the **INITIAL SETUP**, **SETUP RECEIVE**, **SET QUICK-DIAL**, **REMOTE FAX OPT**, plus the **COVERPG SETUP** and **COVERPAGE NOTE** (from **SETUP SEND**) functions are stored permanently.

Setting the Date and Time

Your MFC displays the date and time, and prints it on every fax you send.

In the event of a power failure, the MFC maintains date and time information for several hours. All other settings remain unaffected.

If you have a bad telephone line connection, the other party might hear your voice echoed during the call. Hang up and try the call again.

- 1 Press **Menu**, **1**, **1**, **2**.
- 2 Enter the two digits of the year, and press **Set**. “01” is registered as 2001 in the machine.
- 3 Enter two digits for the month and press **Set**.
- 4 Enter two digits for the day and press **Set**.
- 5 Enter the time in 24 hour format and press **Set**.
- 6 Press **Stop** to exit.

Setting the Station ID

You can store your name, fax number, and telephone number to be printed on the fax Cover Page, and on all fax pages that you send. (See *Electronic Cover Page* in Chapter 6.)

It is important that you enter the fax and telephone numbers in the internationally standardized format, i.e. in accordance with the following strict sequence:

- The “+” (plus) character (press * key)
- Your Country Code (e.g. “44” for the United Kingdom, “41” for Switzerland)
- Your local area code minus any leading “0” (“9” in Spain)
- A space
- Your number on the local exchange, using spaces to aid readability as appropriate.

As an example, if your MFC is installed in the United Kingdom, is to be used for both fax and voice calls, and your national telephone number is 0161 444 5555, then you must set the fax and telephone number parts of your station ID as: +44 161 444 5555

- 1** Press **Menu**, **1**, **1**, **3**.
- 2** Enter your fax number (up to 20 digits) and press **Set**.
- 3** Enter your telephone number (up to 20 digits) and press **Set**.
- 4** Enter your name (up to 20 characters) using the dial pad and the chart. To enter a space press ►.
- 5** Press **Set**.
- 6** Press **Stop**.



- When you enter your name, (See *Entering Text* in Chapter 23.)
- The telephone number you enter is used only for the Call Back Message and Cover Page features.
- If you do not enter a fax number, no additional information can be entered.
- To enter a space, press ► once between numbers and twice between characters.
- If your Station ID has already been programmed, the screen prompts “1” to make a change, or “2” to exit without changing.

Setting the Dialling Mode (Tone/Pulse)

Your MFC is initially set to **TONE**. If you are using a **PULSE** dial line, you can change the setting to **PULSE** by following the steps below.

- 1** Press **Menu**, **1**, **1**, **1**. The screen prompts you to select **TONE** or **PULSE**.
- 2** Use ◀ or ▶ to select the dialling mode.
- 3** Press **Set** when the screen displays the dialling mode you want.
- 4** Press **Stop** to exit.

Although this equipment can use either Pulse or Tone signalling, only the performance of the Tone signalling is subject to regulatory requirements for correct operation. It is therefore strongly recommended that the equipment is set to use the Tone signalling for access to public or private emergency services. The Tone signalling also provides faster call set up.

Setting the Document

- Documents must be between 14.8 and 21.6 cm wide, and 12.7 and 35.6 cm long. Your MFC can scan an image 20.8 cm wide, regardless of how wide the paper is.
- Make sure you insert documents **face down, top edge first**.
- Adjust the paper guides to fit the width of your document.

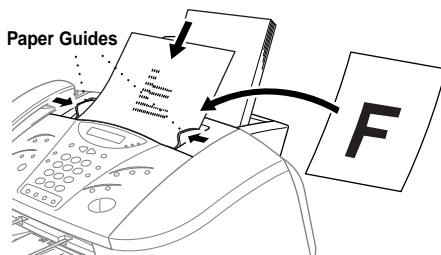

- The automatic document feeder (ADF) can hold up to 20 pages, feeding each one individually through the MFC. Use standard (75 g/m²) paper when using the ADF; if you are using heavier paper, feed each sheet individually to prevent paper jams.
- Press **Resolution** (before you send the fax) to select the resolution for the document you're sending.



- **DO NOT use curled, wrinkled, folded, ripped paper or paper with staples, paper clips, paste or tape attached. DO NOT use cardboard, newspaper, or fabric.**
- **Make sure documents written with ink are completely dry.**
- **To set different resolutions for each page of a multi page document, refer to "Multiple Resolution Transmission".**

Multi-Line Connections (PABXs)

Most offices use a central telephone system, or PABX. The MFC will work with most PABX or key systems that allow a two-wire analogue connection. However, we recommend that you have a separate telephone line for your MFC. You can then leave the MFC in Fax Mode to receive faxes any time of day or night.

If you are installing the machine to work with a PABX:

- 1** It is not guaranteed that the unit will operate correctly under all circumstances with a PABX. Any cases of difficulty should be reported first to the company that handles your PABX.
- 2** If all incoming calls will be answered by a switchboard operator, it is recommended that the Receive Mode be set to **MANUAL**. All incoming calls should initially be regarded as telephone calls.
- 3** The unit may be used with either pulse or tone dialling telephone service.

Using Extension Telephones

It may be that your premises are already wired with parallel extension telephones, or you intend to add extension telephones to your line, in addition to your machine. While the simplest arrangement is straightforward parallel connection, there are some reasons as to why this arrangement will cause unsatisfactory service, the most obvious of which is inadvertent interruption of a facsimile transmission by someone picking up an extension telephone in order to make an outgoing call. Additionally, remote activation may not operate reliably in such a simple configuration.

This machine may also be set to make a delayed transmission (i.e. a transmission at a pre-set time). This pre-set job may coincide with someone picking up an extension handset.

Such problems can easily be eliminated however, if you arrange modification of your extension wiring circuit, such that extension devices are connected “downstream” of your machine, in a master/slave configuration. In such a configuration, this machine can always detect whether a telephone is in use, thus it will not attempt to seize the line during that time. This is known as “telephone off-hook detection.”

The inadvisable configuration is shown in figure 1 below, and the recommended master/slave configuration is shown in figure 2.

This new connection configuration can be arranged by your contacting BT, Kingston upon Hull Telecommunications, your PABX maintainer or a qualified telephone installation company as appropriate. Simply explained, the extension telephone circuit should be terminated on a normal modular plug (BT 431A style), which in turn should be inserted into the modular socket of the white “T”-shaped connector provided as part of the line cord assembly.

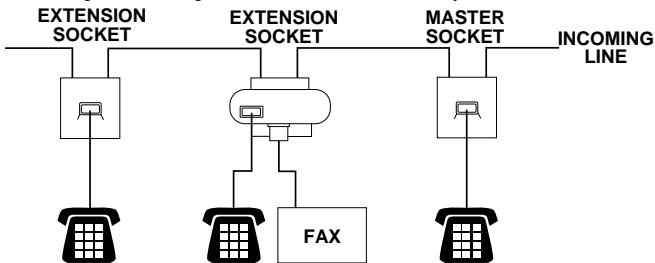

INADVISABLE CONNECTION OF EXTENSION SOCKETS
Fig. 1.

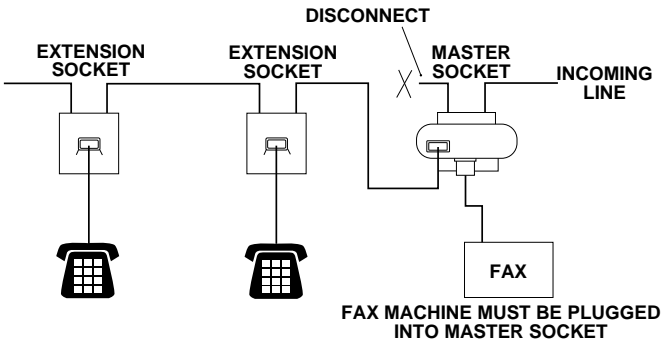

RECOMMENDED CONNECTION OF EXTENSION SOCKETS
Fig. 2.

Connecting an External Telephone Answering Device (TAD)

Sequence

You might choose to connect an additional answering machine. When you have an **external TAD** on the same telephone line as the machine, the TAD answers all calls. The MFC “listens” for fax calling (CNG) tones. If it hears them, the MFC takes over the call and receives the fax. If it does not hear the CNG tones, the machine will not answer the call, and messages can be left on the TAD by callers in the normal way.

The TAD must answer within a maximum of four rings. However, we recommend two rings as the TAD setting. The MFC cannot hear CNG tones until the TAD has answered the call, and with four rings there are only 8 – 10 seconds of CNG tones left for the fax “handshake.” Make sure you carefully follow instructions in this manual for recording your outgoing message. We do not recommend using the toll saver feature on your external answering machine if it exceeds 4 rings.



Do not connect a TAD elsewhere on the same phone line—your machine and TAD will both try to control the line.

Connections

- 1 You may connect an external TAD to your MFC, as shown below.

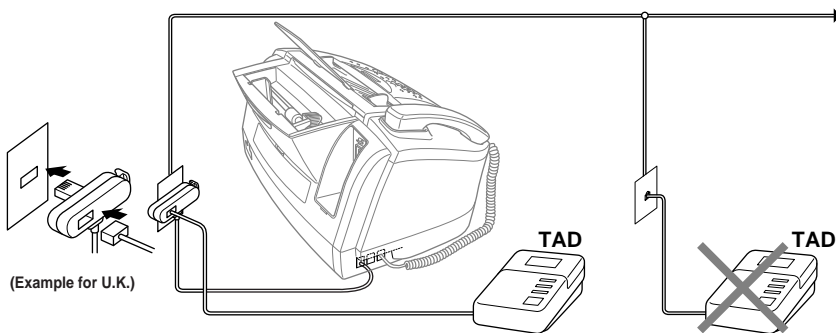

- 2 Set your external TAD to two rings or less. (The MFC’s Ring Delay setting does not apply.)
- 3 Record the outgoing message (see next page).
- 4 Set the TAD to answer calls.
- 5 Set the Receive Mode to TAD:ANSWER MACH.

Outgoing Message (OGM) of External TAD

Timing is important in recording this message. The message sets up the ways to handle both manual and automatic fax reception.

- 1 Limit your speaking to 20 seconds.
- 2 Record 5 seconds of silence at the beginning of your message.
(This allows your MFC time to listen for the fax CNG tones of automatic transmissions before they stop.)
- 3 End your 20-second message by giving your Remote Activation Code for people sending manual faxes. For example:
“After the beep, leave a message or send a fax manually by pressing * 5 1 and **Start.**”

Please note that some faxes that are sent manually cannot be received automatically because some fax machines do not send a fax tone in manual mode. In these cases you must inform callers that they must enter the remote activation code to send a fax.

Connecting an External Telephone

Your MFC is equipped with a handset that you can use as a regular phone. However, you can also connect a separate telephone to your MFC, as shown below.

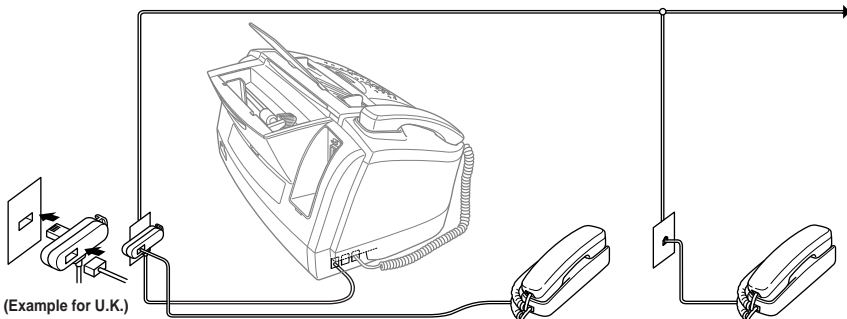

Whenever this external phone (or TAD) is in use, the screen displays **TELEPHONE** (For MFC-830) **EXT. TEL IN USE** (For MFC-840), and, if the MFC's handset is lifted, an alarm sounds.

To disconnect the call on the external phone and switch to the MFC, lift the handset and press **Tel** (for MFC-830).

Control Panel Overview

MFC-830

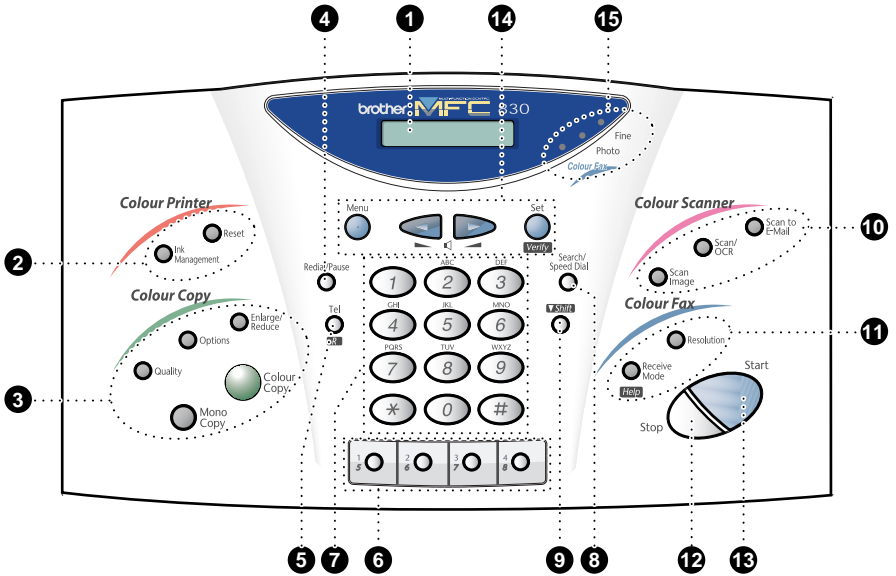

MFC-840

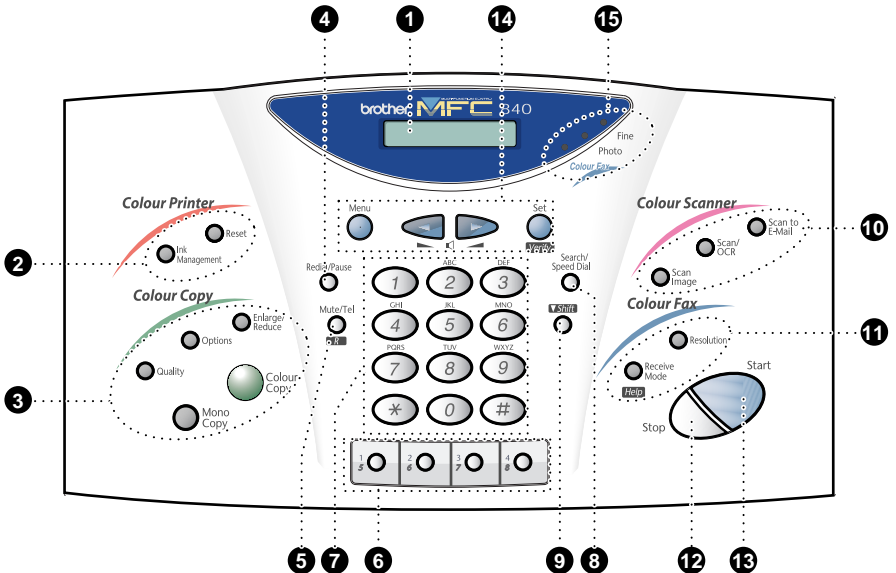

- 1 Liquid Crystal**
LCD displays messages to help you set and operate your MFC.
- 2 Colour Printer Function Keys: Reset**
Clears data from the printer memory, and then resets and restores to the factory default settings.
Ink Management
Cleans the ink print heads and/or resets the ink dot counter after replacing an ink cartridge.
- 3 Colour Copy Function Keys: Enlarge/Reduce**
Lets you reduce or enlarge copies depending on the ratio you select.
Options
You can change the setting of Copy, Video printing and *PhotoCapture Centre. (*...For MFC-840 only)
Quality
Use this key to temporarily change the quality for Copy and Video Printing and PhotoCapture Centre. (For MFC-840 only)
Colour Copy
Makes a full-colour copy.
Mono Copy
Makes a black-and-white or one-colour copy.
- 4 Redial/Pause**
Redials the last number called. Also inserts a pause in autodial numbers.
- 5 R (Recall)**
Press **Shift** and this key to gain access to an outside line and/or to recall the operator or transfer a call to another extension when it is connected to a PABX.
Mute (Only for MFC-840)
Use this key to put calls on hold.
Tel
This key is used to enter into a telephone conversation having picked up the handset in F/T pseudo-ringing mode (For MFC-830) or use to shuttle the line between handset and monitor speaker (For MFC-840).
- 6 One Touch Keys**
These 4 keys give you instant access to previously stored phone numbers.
- 7 Dial Pad**
Dials phone and fax numbers, and can be used as a keyboard for entering information into the MFC.
key lets you switch the dialling type during a telephone call from “PULSE” to “TONE”.
- 8 Search/Speed Dial**
Lets you dial stored phone numbers by pressing a **#** key and a two digit number. Also lets you look up numbers stored in the dialing memory.
- 9 Shift**
Use to access memory locations 5 through 8 in the One Touch keys. Press this key with **Receive Mode** key whenever you want a quick reference Help List printed.
- 10 Scanner Function Keys: Scan Image**
Press this key to scan a colour picture into your graphics application for viewing and editing.
Scan/OCR
Press this key to start scanning a text document. ScanSoft™ TextBridge® will convert it to editable text and display it in your word processor application for further editing.
Scan to E-mail
Press this key to start scanning an original into your E-mail application, setting it up automatically as an attachment.

11 Fax Function Keys:

Receive Mode

Use to select how the MFC will handle incoming calls.

Help

Press this key with **Shift** whenever you want a quick reference Help List printed. The Help List shows how to perform functions, how to register information, and how to get basic information.

Resolution

Sets the resolution when you send a fax.

12 Stop

Stops a fax, cancels an operation, or exits from function mode.

13 Start

Starts an operation, such as sending a fax.

14 Programming Keys:

◀ (Left Arrow)

▶ (Right Arrow)

Volume

Moves the LCD cursor to the left or right. Adjust speaker and ring volume.

Menu

Lets you access the function and programming mode.

Set

Stores a function setting in the MFC.

Verify

Press this key with **Shift** whenever you want to print the Transmission Verification Report for your last transmission.

15 Resolution indicator lights

These LEDs show the resolution mode you selected.

1 Setup

Custom Settings

Volume Settings

Beeper Volume

You can set the beeper to **LOW**, **HIGH** or **OFF**. The MFC comes set to **LOW**. When the beeper is set to **LOW** or **HIGH**, the MFC beeps every time you press a key or make an error, and at the end of sending or receiving a fax.

- 1 Press **Menu, 1, 1, 4**.
- 2 Press **◀** or **▶** to select your setting.
- 3 When the screen displays the setting you want, press **Set**.
- 4 Press **Stop** to exit.

Speaker Volume

You can adjust the speaker volume when your MFC has dialled (on hook dialing), the line is connected and **TELEPHONE** is on the display. You can turn the volume **OFF** or you can select a volume level.

Press **◀** or **▶** to adjust the volume level. The display shows the setting you are choosing. Each key press changes the volume to the next setting. The new setting will remain until you change it again.

Ring Volume

You can adjust the ring volume when your MFC is idle. The ring volume can be turned off for silent reception if required.

Press **◀** or **▶** to adjust the volume level. With each key press, the MFC rings so you can hear the current setting and the display shows the setting you are choosing. Each key press changes the volume to the next setting.

The new setting will remain until you change it again.

PABX and TRANSFER

Your MFC is initially set to be connected with PSTN (Public Switched Telephone Network) lines. However many offices use a central telephone system or Private Automatic Branch Exchange (PABX). Your MFC can be connected to most types of PABX. You can easily gain access to the outside line from your MFC connected to PABX by just pressing **Shift** and **R**.

Also, you can transfer a call to another extension by pressing **Shift** and **R**.

Setting PABX

If your MFC is connected to a PABX system, set **PBX:ON**. If not, set **OFF**.

- 1 Press **Menu, 1, 1, 5**. The screen displays
- 2 Press **◀** or **▶** to select **ON** (or **OFF**), and press **Set** when the screen displays your selection.
- 3 Press **Stop** to exit.

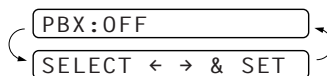



You can program an **R** keypress as part of a number stored in a One Touch or Speed Dial location. When programming the One Touch or Speed dial number (Function menu 1-5-1 or 1-5-2) press **Shift** and **R** first (the screen displays “!”), then enter the telephone number. If you do this, you do not need to press **Shift** and **R** each time before you dial using a One Touch or Speed Dial location. (See *Storing Numbers for Easy Dialling*, in this Chapter.) However, if PBX is set to OFF, you can't use the One Touch or Speed Dial number that a **Shift** and **R** keypress is programmed into.

Setting the Clock Change

You can easily let the MFC's clock gain or lose one hour by using this feature.

- 1 Press **Menu, 1, 1, 6**. The screen displays
- 2 Press **◀** or **▶** to select Summer Time to gain an hour or Winter time to lose an hour, and press **Set**.
- 3 Press **1** to change to Winter Time or Summer Time—**OR**—Press **2** to exit without changing.

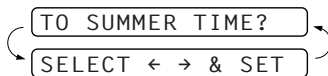

Storing Numbers for Easy Dialling

You can set up your MFC to do three types of easy dialling: One Touch, Speed Dial and Groups for Broadcasting of faxes.

Storing One Touch Dial Numbers

You can store 8 fax/phone numbers that you can dial by pressing one key. You can also store names with these numbers. Even if you lose electrical power, numbers stored in memory will not be lost. When you press a One Touch key, the screen displays the name or number as the call is dialled. (See *One Touch Dialling* in Chapter 4.)



One Touch Dial keys are not the dial pad keys. They are the 4 keys (numbers 1-4). One Touch Dial Numbers 5-8 are accessed by holding down **Shift** while you press the appropriate One Touch Dial key.

- 1 Press **Menu, 1, 5, 1**.
- 2 Press the One Touch Dial key where you want to store a number. The screen displays the location you selected.
- 3 Enter a number (up to 20 digits), and press **Set**. The screen prompts you to enter a name for this number.
- 4 Use the dial pad to enter the name (up to 15 characters). (See *Entering Text* in Chapter 23.)—**OR**—Go to Step 5 to store the number without a name.
- 5 Press **Set**. The screen prompts you to select the type of number this is. Use **◀** or **▶** to select the type you want.

FAX	a fax only number
TEL	a telephone (voice) number
F/T	both a fax and telephone (voice) number

6 Press **Set**. Return to Step 2 to store another One Touch dial number—**OR**—Press **Stop** to exit. When you dial a One Touch dial number, the screen displays the name you have stored or if you have not stored a name, the number you have stored.

Storing Speed Dial Numbers

You can store Speed Dial numbers, which you dial by pressing only four keys. There are 50 Speed Dial locations for MFC-830 and 100 Speed Dial locations for MFC-840. (See *One Touch Dialling* in Chapter 4.)

- 1** Press **Menu**, **1**, **5**, **2**. The screen prompts you to enter a location.
- 2** Use the dial pad to enter a two-digit location (01–50 for MFC-830, 00–99 for MFC-840), and press **Set**. The screen displays your entry, then prompts you to enter the number you're storing.
- 3** Enter the number (up to 20 digits), and press **Set**.
The screen now prompts you to store a name with this number.
- 4** Use the dial pad to enter the name (up to 15 characters). (See *One Touch Dialling* in Chapter 4. Also see *Speed Dialling* in Chapter 4.)—**OR**—go to Step 7 to store the number without a name.
- 5** Press **Set**. The screen prompts you to select the type of number this is. Use ◀ or ▶ to select the type you want.

- FAX** a fax number
- TEL** a telephone (voice) number
- F/T** both a fax and telephone number

6 Press **Set**. Return to Step 2 to store another Speed Dial number—**OR**—Press **Stop** to exit.

Changing One Touch and Speed Dial Numbers

If you try to store a One Touch or Speed Dial number in a location where a number is already stored, the screen displays the current name stored there, then prompts you to either change it or exit.

- 1** Press **1** to change the number stored, or press **2** to exit without making a change.
- 2** Enter a new number.
 - ◆ If you want to erase the number, press **Stop** when the cursor is to the far left of the digits.
 - ◆ If you want to change a digit, use ◀ or ▶ to position the cursor under the digit you want to change, then enter it.
- 3** Follow the directions in Storing One Touch Dial or Speed Dial Numbers.

Scanning Adjustment

Contrast

If your document is very light or very dark, you might want to set the contrast accordingly. Use **LIGHT** to send a light document. Use **DARK** to send a dark document.

- 1 Insert the document, face down, in the feeder.
- 2 Press **Menu, 1, 3, 3**.
- 3 Use **◀** or **▶** to select **AUTO, LIGHT, or DARK**.
- 4 When the screen displays your selection, press **Set**.
- 5 Press **2** if you are finished choosing settings, and go to Step 6—**OR**—Press **1** if you want to select additional settings. The display returns to Setup Send menu.
- 6 Enter a fax number and press **Start** to send a fax.

Resolution

When you have a document in the feeder, you can use the **Resolution** key. Press **Resolution** continuously until you see your selection on the screen. (See *Multiple Resolution Transmission (Not Available for Colour fax)* in Chapter 6.)

- Standard:** Suitable for most typed documents. (**No** lights)
- Fine:** Good for small print; transmits a little slower than Standard resolution.
- Photo:** Use when document has varying shades of grey; slow transmission time.
- Colour fax:** Use to send the original in colour.



You can also change the Fax resolution to S.Fine, please see *Multiple Resolution Transmission (Not Available for Colour fax)* Chapter 6.

Sending Operation

Automatic Transmission

This is the easiest way to send a fax.

IMPORTANT: Do **not** pick up the handset.

- 1 Insert the document face down in the feeder.
- 2 Enter the fax number using One Touch, Speed Dial, Tel-Index or the dial pad.
- 3 Press **Start**. The machine starts scanning the document and the display indicates the job number and how much memory is available. Then the machine will start dialling if it is not sending, receiving or printing the other documents.

Manual Transmission with an External Telephone connected to the Machine (For MFC-830)

Manual transmission lets you hear the dial tone, ringing and fax receiving tones before sending a fax.

- 1 Insert the document face down in the feeder.
- 2 Pick up the handset of the external telephone and listen for a dial tone.
- 3 Enter the fax number you want to call. (You can enter the digits using the dial pad or you can enter a One Touch or Speed Dial number or you can call from the Tel-Index.) (See *One Touch Dialling and Speed Dialling* in Chapter 4.)
- 4 When you hear the fax tone, press **Start**.
- 5 Return the handset to its cradle of the external telephone.

Manual Transmission (For MFC-840)

Manual transmission lets you hear the dial tone, ringing and fax receiving tones before sending the fax.

- 1 Insert the document face down in the feeder.
- 2 Pick up the handset and listen for a dial tone.
- 3 Enter the fax number you want to call. (You can enter the digits using the dial pad or you can enter a One Touch or Speed Dial number or you can call from the Tel-Index.) (See *One Touch Dialling and Speed Dialling* in Chapter 4.)
- 4 When you hear the fax tone, press **Start**.
- 5 To hang up, replace the handset.

Fax Redial

If you're sending a fax manually and the line is busy, you can retry the number by pressing **Redial/Pause**.

- 1 Press **Redial/Pause**.
- 2 Press **Start**.

If you're sending a fax automatically and the line is busy, the machine will automatically redial up to 4 times at 2 minute intervals.

Colour Fax transmission

Your Multi-Function Center allows you to transmit a colour fax.

- 1 Place the document face down in the feeder.
- 2 Press **Resolution** to select the Colour Fax.
- 3 Enter the fax number using the dial pad, One Touch, Speed Dial or Search.
- 4 Press **Start**.



When you send a colour fax, the MFC starts sending the fax without scanning the original into memory.

Dual Access (Not Available for Colour fax)

You can scan up to 50 messages into the fax memory, even while the machine is receiving or sending another fax (from the memory). You can set temporary settings for each fax you're scanning, except Timer and Polling.

If you get a **MEMORY FULL** message while scanning the first page of a fax, press **Stop** to cancel a scan. If you get a **MEMORY FULL** message while scanning in a subsequent page, you'll have the option to press **Start** to transmit the pages scanned so far, or to press **Stop** to cancel the operation.

- 1 Make sure the document feeder is empty.
- 2 Place the document in the feeder.
- 3 Enter the fax number.
- 4 Press **Start**. The machine starts scanning the document and the screen displays the job number (#XX) of the fax, and how much memory is available. When the machine starts dialling you can immediately repeat Steps 1 through 4 for the next fax.



Your machine normally operates in Dual Access mode. However, to send a colour fax, you must override Dual Access and use Real Time Transmission.

Real Time Transmission

When memory is full, the machine cannot continue to scan documents into memory before sending. However, you can turn on **REAL TIME TX**. Then place the documents in the feeder and enter the fax number. As soon as the phone line is free, the machine starts dialling and sending the fax.

- 1 Place the document in the feeder.
 - 2 Press **Menu, 1, 3, 9**.
The screen displays
-
- 3 To change the default setting, press **◀** or **▶** to select **ON** (or **OFF**) and press **Set**. Go to Step 6. —OR— For the next fax transmission only, press **◀** or **▶** to select **NEXT FAX ONLY**.
 - 4 Press **Set**.
 - 5 For the next fax only, press **◀** or **▶** to select **ON** (or **OFF**) and press **Set**.
 - 6 Press **1** if you want to select additional settings. The display returns to the **SETUP SEND** menu. —OR— Press **2** if you have finished choosing settings and go to Step 7.
 - 7 Enter the fax number and press **Start**.



This setting has no effect on Colour faxes.

3 Receiving a Fax

Receive Mode Settings

Setting the Ring Delay

The Ring Delay setting determines the number of times the MFC rings before it answers. See *Operation from an External or Extension Telephone* in Chapter 7. Also see *For Fax/Tel Mode Only* in Chapter 7.

- 1 Press **Menu**, **1**, **2**, **1** and press **Set**.
- 2 Press **◀** or **▶** to select how many times the line rings before the MFC answers (01-04).
- 3 Press **Set** when the screen displays your selection.
- 4 Press **Stop** to exit.

Setting the F/T (Fax/Tel) Ring Time (Fax/Tel Mode Only)

You need to determine how long the MFC will give its special F/T pseudo-ring when you have a voice call. This ringing happens after the initial ringing from the phone company. Only the MFC rings, for 20, 30, 40, or 70 seconds; no other phones on the same line ring the special F/T pseudo ring. However, you can answer the call on any extension phone on a separate wall socket on the same line as the MFC. (See *Operation from an External or Extension Telephone* in Chapter 7.)

- 1 Press **Menu**, **1**, **2**, **2**.
- 2 Press **◀** or **▶** to select how long the MFC will ring to alert you that you have a voice call, and press **Set** when the screen displays your selection.
- 3 Press **Stop** to exit.

Now, when a call comes in and the MFC is set to Fax/Tel Mode, all phones on this line will ring the number of times you selected in Ring Delay.

You can let the MFC pick up and detect if it's a fax or voice call. If it's a fax call, the MFC prints the fax. If it's a voice call, the MFC signals you with an F/T pseudo-ring for the length of time you selected in F/T Ring Time.



Even if the caller hangs up during the F/T pseudo-ringing, the MFC continues the F/T pseudo-ringing for the set time.

Please note that some faxes cannot be received automatically in Fax/Tel mode, because some fax machines do not send the standard Group 3 calling tone (“CNG”).



This MFC does not re-generate ringing conditions to any extension telephones. Any such extension telephones will only ring during the period set on ring delay.

Fax Detect

When you use this feature, it is not necessary to press **Start** when you answer a fax call and hear calling beeps. Just hold the handset and wait for several seconds. When you see **RECEIVE** on the MFC screen or when you hear “chirps” through the handset of an extension phone connected to another wall extension, just replace the handset, and your MFC does the rest. Selecting **ON** allows the MFC to receive fax calls automatically, even if you lift the handset of an extension or external phone. Selecting **SEMI** (Only for MFC-840) lets the fax machine receive the call only if you’ve answered it at the machine. Selecting **OFF** means you’ll have to activate the MFC yourself, by pressing **Start** or by pressing * 5 1 if you are not at your MFC. See *Operation from an External or Extension Telephone* in Chapter 7. Also see *For Fax/Tel Mode Only* in Chapter 7.

In case Fax Detect does not work, because of a poor phone line connection, just press **Start** or press the Activation Code * 5 1.

- 1 Press **Menu**, **1**, **2**, **3**.
- 2 Use ◀ or ▶ to select **ON**, **SEMI** (MFC-840) or **OFF**, and press **Set** when the screen displays your selection.
- 3 Press **Stop** to exit.

If you’ve set the feature to ON, but your MFC doesn’t automatically connect a fax call when you lift an external or extension phone handset, press * 5 1.

At the machine, lift the handset and press **Start**.

Receiving a Fax

Select Receive Mode



You’ll need to connect an external telephone to select Fax/Tel (**F/T**) or Manual Mode. (For MFC-830 only)

Receive Mode	For
1. Manual	Use this function if you receive many telephone calls and few fax messages. You must answer all calls yourself. If you hear fax tones, wait until the fax machine takes over the call automatically, then hang up (see Fax Detect function).
2. Fax Only	Use this function if you want to receive fax messages only (no telephone calls). The fax machine should be connected on its own line. The machine automatically answers every call as a fax call. You cannot receive a voice call, but, if you have connected an External telephone, you can still dial out and make voice calls. (This setting is recommended if the fax machine is on its own dedicated line.)

Receive Mode

For

3. Fax/Tel (F/T)

Use this function if you expect to receive many fax messages and few phone calls. The machine automatically answers every call. If the call is a fax, it prints the fax. If the call is not a fax, it signals you with an F/T pseudo-ring, different from the phone company ringing, to alert you to pick up the call. If you select this setting, you'll need to set the Ring Delay and F/T Ring Time features (on the following pages).

4. TAD

This is the only setting in which you can use an **external** answering machine. Your telephone answering device is connected to your machine, and answers every call. Once the external telephone answering device (TAD) answers, the machine listens for fax tones. If it detects fax tones, fax messages are printed.

The TAD setting works only with an external telephone answering device (TAD). Ring Delay and F/T Ring Time do not work in this setting.

To select or change your Receive Mode

1 Press **Receive Mode**. The screen displays your current selection.

2 Press the key again and the next selection appears. After 2 seconds, the screen returns to the date and time display, along with your new Receive Mode setting.

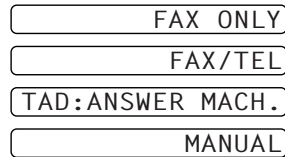

If you are changing the Receive Mode while in another operation, the screen returns to that operation.



Current Receive Mode.....

MNL: **MANUAL**
FAX: **FAX ONLY**
F/T: **FAX/TEL**
TAD: **EXTERNAL ANSWERING SYSTEM**

Manual Reception (Manual Mode)

When you set the Receive Mode to manual, you must answer each incoming call yourself. Select this mode by pressing **Receive Mode** key. Here is what you should do when using Manual Mode:

If You Get a...

1. Regular phone call
2. Phone call and request to send a fax
3. Fax tone...

Then You Should...

Talk as you normally would.
Press **Start** when finished talking, and replace the handset.
NOTE: Sender must also press Start.
Wait until the fax machine takes over the call or press **Start**.

Automatic Fax Only Reception (Fax Only Mode)

You can automatically receive all your faxes in Automatic Fax Reception mode. Select this mode by pressing **Receive Mode**.

Printing a Reduced Incoming Document

You can always reduce the size of an incoming fax to a fixed percentage with your MFC. If you choose **AUTO**, the MFC chooses the level of reduction for you regardless of the original size of the incoming document.

- 1 Press **Menu**, **1**, **2**, **5**. The screen displays
- 2 Use **◀** or **▶** to select the reduction ratio you want—**AUTO**, **100%**, **88%**, **83%**, or **70%**. Choose **100%** if you don't want a reduction.
- 3 Press **Set** when the screen displays your selection.
- 4 Press **Stop** to exit.

5. REDUCTION



If you receive faxes that are split on two pages, change the reduction to **AUTO**—**OR**—choose a lower reduction percentage.



- When you use Auto Reduction to reduce incoming documents to fit on one page of recording paper, you can do so only as long as the original document is not longer than 35 cm. If the original is longer than 35 cm, the data will not be reduced and will carry over to print on a second page.
- When you use Auto Reduction and you receive an incoming document that is smaller than your recording paper, no reduction will take place, and you will get the same size recorded as the original.

Reception into Memory

As soon as the paper cassette becomes empty during fax reception, the screen will display “**CHECK PAPER**”; please put some paper in the paper cassette. (See *Loading Paper* in Preparation and Simple Use Guide.)

If the MEMORY RECEPTION switch is ON at this time...

The current fax reception will continue, with the remaining page(s) being stored in memory, subject to available memory. Subsequent incoming faxes will also be stored into memory until the memory is full, following which no further incoming fax calls will be automatically answered; all data will be printed as soon as fresh paper is put in the paper cassette, then press **Start**.

If the MEMORY RECEPTION switch is OFF at this time...

The current fax reception will continue, with the remaining page(s) being stored in memory, subject to available memory. Subsequent incoming fax calls will not be automatically answered until fresh paper is put in the paper cassette. The last fax received will be printed as soon as fresh paper is put in the cassette, then press **Start**.

1 Press **Menu, 1, 2, 6**. The screen displays

6 . MEM . RECEIVE

2 Use ◀ or ▶ to select **ON** or **OFF**, and press **Set** when the screen displays your selection.

3 Press **Stop** to exit.

Printing a Fax from Memory

If you have fax storage ON for remote retrieval, you can still print a fax from the machine's memory when you are at your machine: (See *Setting Fax Storage* in Chapter 9.)

1 Press **Menu, 1, 7, 4**.

2 Press **Start**.

3 After all the data saved in the memory is printed out. Press **Stop**.

Making Voice Calls

You can use your machine to make voice telephone calls, by dialling manually or by using One Touch or Speed Dial memory.



USING THE UNIT WITH AN EXT. TEL (Only for MFC-830)

If you connect an external telephone to the unit, your fax machine can be used to make normal telephone calls.

Manual Dialling

Manual dialling is simply pressing all of the digits of the phone number.

- 1 Pick up the handset.
- 2 When you hear a dial tone, dial the number, using the dial pad.
- 3 To hang up, replace the handset.

One Touch Dialling

- 1 Pick up the handset.
- 2 When you hear a dial tone, press the One Touch Dial key of the location you want to call. (See *Storing One Touch Dial Numbers* in Chapter 1.)
- 3 To hang up, replace the handset.



If you try to use a One Touch location with no number stored in it, you hear a warning sound, and screen displays **NOT ASSIGNED**. The display returns to normal after 2 seconds.



If you are sending a fax, press **Start** after pressing the One Touch Dial key. If you picked up the handset, press **Start** when the receiving fax machine answers with fax tones.

Speed Dialling

- 1 Pick up the handset.
- 2 When you hear a dial tone, press **Search/Speed Dial**, then press **#** and the two-digit Speed Dial number. (See *Storing Speed Dial Numbers* in Chapter 1.)
- 3 To hang up, replace the handset.



If you are sending a fax, press **Start** after pressing the Speed Dial number. If you picked up the handset, press **Start** when the receiving fax machine answers with fax tone.

Mute (Only for MFC-840)

- 1 Press **Mute/Tel** to put a call on hold.
- 2 You can put down the handset without disconnecting the call.
- 3 Pick up the machine's handset to release the call from hold. Picking up an extension handset will not release the call from hold.

Pause

Press **Redial/Pause** to insert a pause between digits to be dialed.



If your fax machine is connected to a PABX, you may need to insert an additional number prefix (e.g. "9") and a "pause" before each fax or telephone number to gain access to the outside line. When you press **Redial/Pause**, a dash "-" will appear on the display. By storing a pause, you can create a delay of 3.5 seconds.

On Hook Dialling

- 1 Dial the number by using the dial pad or One Touch Dial key, or Speed Dial and # then two-digit **Speed Dial** number.
- 2 The number you are dialling, or the name you have stored for One Touch or Speed Dial is displayed on the LCD.
- 3 Press **Start**.
- 4 Pick up the handset (and press **Tel** for MFC-830) when you hear the other end from the monitor speaker.



When you make a call by pressing **Start** after dialling, you can listen to the other end of the line from the monitor speaker, but they can't hear you unless you pick up the handset (and press **Tel** for MFC-830).

If you accidentally press **Tel** before lifting the handset, the call will be disconnected.

Search

You can search for names you have stored in One Touch and Speed Dial memories. Names are stored alphabetically. (See *Storing One Touch Dial Numbers and Storing Speed Dial Numbers* in Chapter 1.)

- 1 Press **Search/Speed Dial**, then enter the first letter of the name you're looking for.
- 2 Press ◀ or ▶ to search the memory.
- 3 When the screen displays the name you want to call, press **Start** to begin dialling.
- 4 Pick up the handset (and press **Tel** for MFC-830) when the other party answers. (The speaker works only one way; the other party won't be able to hear you unless you pick up the handset.)
- 5 When the call is over, hang up.

Chain Dialling

You can store very long dialling sequences by dividing them and setting them up as One Touch and Speed Dial numbers. Then while dialling, you can combine two or more One Touch and/or Speed Dial numbers and even include manual dialling using the dial pad. You can use these numbers in any combination. The combined number will be dialled, in the order you entered it, as soon as you press **Start**.

For example:

You store “555” on One Touch Dial key **01** and “7000” on One Touch Dial key **02**. If you press One Touch **01**, **02** and **Start**, you can dial “555-7000”. To temporarily change a number, you can substitute part of the number with manual dialling using the dial pad. So, if you press One Touch **01** and press **7001** using the dial pad, you can dial “555-7001”.

Using access codes is easy. Sometimes you may want to choose from the among several long distance carriers when you make a call; rates may vary depending upon the time and destination. To take advantage of low rates, you can store the access codes or long-distance carriers as One Touch and Speed Dial numbers.

Call Reservation with an External Telephone (Only for MFC-830)

If you connect an external telephone to the unit, you can send a fax and then talk to the recipient using the Call Reservation feature. After your fax has been printed on the receiving end, the receiving fax machine will ring as if it were receiving a telephone call. When the recipient picks up the handset, your fax machine will ring. Then you can pick up your handset of the external telephone and press **Tel**, then start a conversation.

For further information on how to use this function, See chap.6.

Tone/Pulse

If you have pulse dialling service, but need to send tone signals (for telephone banking, for example), follow the directions below. If you have touch tone service, you do not need this feature to send tone signals.

- 1 Lift the handset.
- 2 Press **#**. Any digits dialled after this sends tone signals.
- 3 When you hang up, the machine returns to pulse dialling service.

Fax/Tel (F/T) Mode

When you share one line for your telephone and fax machine, in the Fax/Tel (F/T) Mode, the fax machine can determine whether an incoming call is a fax or a telephone call. (See *Select Receive Mode* in Chapter 3.)

Tel Key

Only for MFC-830

This key is used to enter into a telephone conversation having picked up the handset of an external telephone in F/T pseudo-ringing etc.

Only for MFC-840

If you press **Tel** when you are talking lifting the handset with the other end, you can hear the other end from machine’s monitor speaker, but the other end cannot hear you.

5 Printing Reports

Types of Reports

You can print the following lists and reports:

1. XMIT REPORT

Choose if Transmission Verification Report is printed after all Faxes are sent.

2. JOURNAL

Journal lists information about the last 50 incoming and outgoing faxes. TX means Transmit; RX means Receive.

3. QUICK-DIAL

Lists names and numbers stored in One Touch and Speed Dial memory, in numerical order.

4. TEL. INDEX

Quick-Dial list (above), in alphabetical order.

5. SYSTEM SETUP

Lists settings for **INITIAL SETUP**, **SETUP RECEIVE**, **SETUP SEND**, **PRINT REPORT**, **REMOTE FAX OPT** and **MISCELLANEOUS**.

6. MEMORY STATUS

Lists summary information and amount of occupied memory.

7. ORDER FORM

You can print an accessories order form to your Brother dealer for service.

Transmission Report

Transmission Verification (Xmit) Report

You can use the Xmit Report as confirmation that you sent a fax. This report lists the name or fax number of the receiving party, the time and date of transmission, and if the transmission was successful.

When the feature is **OFF**, the report is printed automatically only if an error occurred during transmission. If the report indicates **ERROR**, send the document again. If the report indicates you should check the readability of certain pages, resend those pages.

If you typically send multiple faxes to the same destinations, you may need a reminder to identify each fax transmission. You can select **OFF+IMAGE** or **ON+IMAGE** to print a portion of the first page of the fax message on the report.

1 Press **Menu**, **1**, **6**, **1**.

2 Press **◀** or **▶** to select **OFF**, **OFF+IMAGE**, **ON** and **ON+IMAGE**.

3 Press **Set**.

4 Press **Stop** to exit.



When the MFC is idle, you can print the Transmission Verification Report by pressing **Shift** and **Verify** when you wish to confirm the last transmission was successful or not.

Setting Reports

To Print a Report

- 1 Press **Menu, 1, 6**.
- 2 Enter the number of the report you want to print. For example, press **4** to print the **TEL INDEX**.
- 3 Press **Start**.
- 4 Press **Stop** to exit.

Journal Period

You can set the MFC to print activity reports at specific intervals (1, 3, 6, 12, 24 hours, 2, 4 or 7 days). If you set the interval to **OFF**, you can print the report by following the steps in the previous section.

- 1 Press **Menu, 1, 6, 2**.
- 2 Press **◀** or **▶** to display **JOURNAL PERIOD**, and press **Set**.
- 3 Press **◀** or **▶** to choose your setting. If you choose 7 days, the screen prompts you to choose a day at which to begin the 7-day countdown.
- 4 When the screen displays the setting you want, press **Set**.
- 5 Enter the time to begin printing, in 24-hour format (for example, enter 19:45 for 7:45 PM), and press **Set**.
- 6 Press **Stop** to exit.

6 Advanced Sending

Advanced Operations

Electronic Cover Page

The cover page is sent to the receiving party's machine. Your cover page includes the name stored in the One Touch or Speed Dial memory, if you have used this feature to start the call.

The cover page indicates the fax is from your Station ID, and the number of pages you're sending. If you have **COVERPG SETUP** set to **ON** (Function menu 1-3-1), the number of pages remains blank.

You can select a comment to include on your cover page, or you can select **1. NOTE OFF** if you do not wish to include a comment. (See *Entering Text* in Chapter 23.)

1 . NOTE OFF

As well as using one of the comments above, you can also enter up to two customized messages, each 27 characters long. (See *Entering Text* in Chapter 23.)

2 . PLEASE CALL

Most of the **SETUP SEND** functions are temporary settings that allow you to make adjustments for each document you send. However, so you can set up your cover page and cover page comments in advance, the Cover Page Setup and Cover Page Message functions will change their default settings.

3 . URGENT

4 . CONFIDENTIAL

Cover Page for Next Fax Only

Make sure Station ID is set up (See *Setting the Station ID* in Preparation and Simple Use Guide.)

This feature does not work without the Station ID.

You can set the MFC to send a cover page with a particular document. This cover page will include the number of pages in your document.

- 1 Insert the document in the feeder.
- 2 Press **Menu, 1, 3, 1**.
- 3 Press **Set** when the screen displays **NEXT FAX ONLY**.
- 4 Press **◀** or **▶** to select **ON** (or **OFF**), and press **Set**.
- 5 Press **◀** or **▶** to view the comment selections.
- 6 Press **Set** when the screen displays your selection.
- 7 Enter two digits to indicate the number of pages you are sending. (Enter 00 to leave the number of pages blank.) If you make a mistake, press **◀** to back up and re-enter the number of pages.
- 8 Press **Set**. The screen prompts you to continue.
- 9 Press **1** if you want to select additional settings. The display returns to the **SETUP SEND** menu—**OR**—Press **2** if you are finished choosing settings, and go to Step 10.
- 10 Enter the fax number and then press **Start**.

Always Send Cover Page

Make sure Station ID is set up. (See *Setting the Station ID* in Preparation and Simple Use Guide.) This feature does not work without the Station ID.

You can set the MFC to send a cover page whenever you send a fax. The number of pages in your fax is not included when you use this setting.

- 1 Press **Menu, 1, 3, 1**.
- 2 Press **◀** or **▶** to select **ON** or **OFF**.
- 3 Press **Set** when the screen displays **COVERPAGE:ON**. (If you select **ON**, a coverpage is always sent when you send a fax.)
- 4 If you selected **ON**, the screen displays the cover page comment options. Press **◀** or **▶** to view comment selections.
- 5 Press **Set** when the screen displays your selection. The screen prompts you to continue.
- 6 Press **1** if you want to select additional settings. The display returns to the **SETUP SEND** menu—**OR**—Press **2** to exit if you are finished choosing settings.

Using a Printed Cover Page

If you prefer using a printed cover page that you can write on, you can print the sample page and attach it to your fax.

- 1 Press **Menu, 1, 3, 1**.
- 2 Press **◀** or **▶** to select **PRINT SAMPLE**, and press **Set** when the screen displays your selection.
- 3 Press **Start**. Your MFC prints a copy of your cover page.

Composing Your Own Comments

- 1 Press **Menu, 1, 3, 2**. The screen displays: **COVERPAGE NOTE**.
- 2 Use **◀** or **▶** to choose position 5 or 6 for your customized comment, and press **Set**.
- 3 Use the dial pad to enter your customized comment. (See *Entering Text* in Chapter 23.)
- 4 Press **Set**. The screen prompts you to continue
- 5 Press **1** if you want to select additional settings. The display returns to the **SETUP SEND** menu—**OR**—Press **2** to exit.

Overseas Mode

Sometimes, when sending a fax to overseas numbers, problems may be experienced. This mode makes the MFC work better for such calls.

After you send a fax using this feature, the feature turns itself off.

- 1 Insert the document.
- 2 Press **Menu, 1, 3, 5**.
- 3 Press **◀** or **▶** to select **ON** (or **OFF**), and press **Set** when the screen displays your selection.
- 4 Press **1** if you want to select additional settings. The display returns to the **SETUP SEND** menu—**OR**—Press **2** if you are finished choosing settings and go to Step 5.
- 5 Enter the fax number you're calling, and press **Start**.

Call Reservation

You can send a fax and let the other party know that you want to speak to them after the fax transmission is complete. The other fax machine will ring as if it were receiving a telephone call; if the other party picks up the handset, your MFC will ring. Lift the handset (and press **Tel** for MFC-830) to have a conversation.

If you set Call Reservation and Call Back message to **ON**, your machine leaves a message if the other party does not answer.

- 1 Insert the document in the feeder.
- 2 Press **Menu, 1, 3, 6**. The screen displays the current setting for Call Reservation.
- 3 Press **◀** or **▶** to select **ON** (or **OFF**).
- 4 If you set Call Reservation to **ON**, press **Set** when the screen displays your selection. The screen displays the current setting for Call Back Message.
- 5 Press **◀** or **▶** to select **ON** (or **OFF**), and press **Set** when the screen displays your selection.
- 6 Press **1** if you want to select additional settings. The display returns to the **SETUP SEND** menu—**OR**—Press **2** if you are finished choosing settings, and go to Step 7. The screen prompts you to enter the fax number you want to call.
- 7 Enter the fax number, and press **Start**.
- 8 If you've set Call Reservation to **ON**, pick up your handset if the MFC rings.



You cannot use auto redial with Call Reservation. You cannot use Call Reservation with Delayed Transmission or with Polling. You must register your Station ID to set Call Back Message to **ON**.

Print Sample Call Back Message

- 1 Press **Menu, 1, 3, 6**.
- 2 Press **◀** or **▶** to select **PRINT SAMPLE**, and press **Set**.
- 3 Press **Start**.

Delayed Transmission (Timer) (Not Available for Colour Fax)

You can use this function to send a fax up to 24 hours later.

- 1 Insert the document in the feeder.
- 2 Press **Menu, 1, 3, 7**.
- 3 Enter the time you want the fax to be sent, in 24-hour format (for example, enter 19:45 for 7:45 PM), and press **Set**.
- 4 Press **1** to select **DOC**—**OR**—Press **2** to select **MEMORY**. If you select **1.DOC**, the MFC will not start scanning the document until the time it is due to be sent, so the document must be left in the feeder.
- 5 Press **1** if you want to select additional settings. The display returns to the **SETUP SEND** menu—**OR**—Press **2** if you are finished choosing settings and go to Step 6. The screen prompts you to enter the fax number.
- 6 Enter the fax number, and press **Start**. The MFC will wait until the time you have entered to send the fax.

Delayed Batch Transmission

Before sending the delayed faxes, your Brother machine will economize by sorting all the documents in memory by destination and scheduled time. All delayed faxes scheduled at the same time to the same fax number will be sent as one transmission.

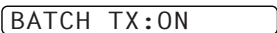
- 1 Press **Menu, 1, 3, 0**.
- 2 Press **◀** or **▶** to select **ON** (or **OFF**) and press **Set**.
- 3 Press **Stop** to exit.

Broadcasting (Not Available for Colour Fax)

Broadcasting is automatically sending the same fax message to multiple fax numbers. Using the **Set** key, you can include up to 8 One Touch locations, up to 50 Speed Dial locations (MFC-830) and 100 Speed Dial locations (MFC-840), and up to 50 manually dialled numbers (maximum of 108 locations for MFC-830 and 158 locations for MFC-840) if you did not use up any locations for Groups, access codes or credit card numbers). Real Time Transmission needs to be set to **OFF**. However, available memory will vary with the types of jobs in memory and numbers of locations used for broadcasting. If you broadcast to more than the maximum locations available, you will not be able to setup transmissions using dual access and the timer.

The easiest way to broadcast is to first combine frequently used One Touch and Speed Dial numbers as a Group, which uses up a One Touch Key. (Remember, you can have up to six Groups and Quick-Dial numbers can be included in more than one Group). Then by pressing **Set** between each location, you can include One Touch, Speed Dial, Groups, and manual dialling (using the dial pad) in the same broadcast. Use the **Search** to help you choose the numbers easily.

After the broadcast is completed, a Broadcast Report will be printed automatically to let you know the results.

- 1 Insert the document into the feeder.
- 2 Enter a number using One Touch, Speed Dial, Group number, Search or the dial pad. (See *Setting Groups for Broadcasting* in Chapter 6.)
Example: Group number
- 3 Press **Set**. You will be prompted to press the next number.
- 4 Enter the next number.
Example: Speed Dial
- 5 Press **Set**.
- 6 Enter the next fax number.
Example: Manual dialling, using the dial pad.
- 7 Press **Start**.

Your MFC will read the documents into memory and then start sending faxes to all the numbers you entered.



- To stop the broadcasting in progress, press **Stop**. The display asks if you want to cancel all locations or just the location that is being sent to.
- Enter the long dialling sequence numbers as you normally would, but keep in mind that each key counts as one location, so the number of locations you can call becomes limited.
- If the line is busy or a connection could not be made for some other reasons while broadcasting, the MFC will redial the number automatically.
- If the memory is full, press **Stop** to abort the job or press **Start** to send the portion that is in the memory (if more than one page has been scanned).

Setting Groups for Broadcasting

Groups allow you to send the same fax message to many fax numbers by pressing only one One Touch Dial key (This is called Broadcasting.). **First**, you'll need to store each fax number as a One Touch or Speed Dial number. **Then**, you can combine them into a Group. Each Group uses up a One Touch Dial key. Finally, you can have up to 6 small Groups, or you can assign up to 57 numbers (MFC-830) and 107 numbers (MFC-840) to one large Group. (See *Storing One Touch Dial Numbers* in Chapter 1. Also see *Storing Speed Dial Numbers* in Chapter 1.)

- 1 Press **Menu**, **1**, **5**, **3**. The screen displays **SELECT ONE-TOUCH**.
- 2 Select a One Touch Dial key where you wish to store the number. (For example, press One Touch Dial key **02** to use as a Group.)
- 3 Use the dial pad to enter the Group Number (for example, press **1** for Group 1).
- 4 Press **Set**. To include One Touch or Speed Dial numbers in the Group, enter them as if you were dialling. For example, for One Touch Dial key **5**, press One Touch Dial key **5**. For Speed Dial location 09, press **Search/Speed Dial**, then press **0**, **9** on the dial pad. The LCD shows *05, #09.

G01:*05#09_
- 5 Press **Set**. The screen prompts you to enter a name.
- 6 Use the dial pad to enter a name for the group (for example, NEW CLIENTS) and press **Set**. (See *Entering Text* in Chapter 23.)
- 7 Press **Stop** to exit.



You can print a list of all One Touch and Speed Dial numbers. Group numbers will be marked in the column of “**GROUP**”. (See *Printing Reports* in Chapter 5.)

Cancelling a Scheduled Job in Memory

You can cancel tasks you’ve scheduled, such as Delayed Fax, Delayed Polling Receive or Polling Transmit.

If the MFC is idle,

1 Press **Menu, 1, 4**.

Any waiting jobs appear on the display. If nothing is waiting, the screen displays **NO JOB WAITING**.

2 If you have more than two jobs waiting, use ◀ or ▶ to select the job you want to cancel. Press **Set** when the screen displays your selection.—**OR**—If you have only one job waiting, go to step 3.

3 Press **1** to cancel—**OR**—Press **2** to exit without cancelling.

To cancel another job, return to step 2.

4 Press **Stop** to exit.



- If the MFC is busy, press **Stop**, then follow Steps 2 through 4 to cancel a job.
- You can check which jobs are remaining in memory by following Steps 1 and 2 above.

Multiple Resolution Transmission (Not Available for Colour fax)

Use this feature to select separate resolution settings for each page of the fax you’re sending. This could be useful if you’re sending a fax with photos and letters, or some pages with small print and others with normal print. Resolution settings return to **STANDARD** after the fax is sent.

1 Insert documents in feeder, then press **Menu, 1, 3, 4**.

2 Use ◀ or ▶ to select resolution for page 1, and press **Set**.

3 Repeat Step 2 for subsequent pages. Press **Stop** when you’re finished.

4 Press **1** if you want to select additional settings. The display returns to the Setup Send menu—**OR**—Press **2** if you are finished choosing settings, and go to Step 5. The screen prompts you to enter the fax number you want to call.

5 Enter the fax number you’re calling, and press **Start**.

Standard—For most typed documents.

Fine—Good for small print; transmit slower than standard resolution,

S.Fine—Good for small print or art work; transmits slower than fine resolution.

Photo—Use when document has varying shade of grey; slowest transmission time.

TX Lock

This feature allows you to prevent unauthorised access to the fax machine. When switched ON, TX Lock prohibits most functions. The following functions listed are available while TX Lock is switched ON.

- Receiving faxes
- Scheduled Delayed Transmission*
- Polling*
- Fax Forwarding*
- Remote Retrieval

* Provided it was set before TX Lock was switched ON.

Using TX Lock

You must use a password to switch TX Lock ON and OFF.

Setting Up the TX Lock for the First Time

- 1** Press **Menu, 1, 0, 2**.
The screen prompts you to enter the password, and then press **Set**.
- 2** Enter a 4-digit number as a password.
- 3** Press **Set**.
The screen prompts you re-enter the password.
- 4** Re-enter the password and press **Set**.
- 5** The screen displays
- 6** Press **◀** or **▶** to choose **SET TX LOCK**.
- 7** Press **Set**. The screen prompts you to enter the password.
- 8** Enter a 4-digit password, followed by **Set**.
This is the same as the security password of your machine already stored.

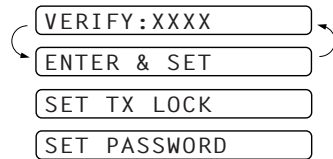
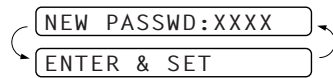

The screen displays **ACCEPTED** for 2 seconds, followed by **TX LOCK MODE** - TX Lock is now switched ON.



If the password you enter at Step 8 is incorrect, the screen would display **WRONG PASSWORD**. After 2 seconds the display will then return to normal (displaying the date & time). You must then start from Step 1 to set TX Lock.

Changing the TX Lock Password

- 1 Press **Menu**, **1**, **0**, **2**.
- 2 Press **◀** or **▶** to choose **SET PASSWORD**.
- 3 Press **Set**.
The screen prompts you to enter the old password.
- 4 Enter the current password.
- 5 Press **Set**.
The screen prompts you to enter the new password.
- 6 Enter a 4-digit number as a new password.
- 7 Press **Set**.
The screen prompts you to re-enter the new password.
- 8 Enter the new password again and press **Set**.
- 9 Press **Stop** to exit.

SET TX LOCK

SET PASSWORD

OLD PASSWD: XXXX
ENTER & SET

NEW PASSWD: XXXX
ENTER & SET

VERIFY: XXXX
ENTER & SET

Switching TX Lock ON

- 1 Press **Menu**, **1**, **0**, **2**. The screen displays
- 2 Press **◀** or **▶** to choose **SET TX LOCK**.
- 3 Press **Set**. The screen prompts you to enter the password.
- 4 Enter a 4-digit password, followed by **Set**.
This is the same as the security password of your machine already stored.

SET TX LOCK

SET PASSWORD

PASSWORD: XXXX
ENTER & SET

The screen displays **ACCEPTED** for 2 seconds, followed by **TX LOCK MODE** - TX Lock is now switched ON.



If the password you enter at Step 4 is incorrect, the screen would display **WRONG PASSWORD**. After 2 seconds the display will then return to normal (displaying the date & time). You must then start from Step 1 to set TX Lock.

Switching OFF TX Lock

- 1 When TX Lock is switched ON, press **Menu**.
The screen Prompts you to enter the password, followed by **Set**.
- 2 Enter a 4-digit password and press **Set**.
The screen displays **ACCEPTED**, then after 2 seconds the display reverts to normal. TX Lock is now switched OFF.

PASSWORD: XXXX
ENTER & SET



If the password you enter at Step 2 is incorrect, the screen would display **WRONG PASSWORD**. After 2 seconds the display will then return to displaying **TX LOCK MODE**. You must then start from Step 1 to switch OFF TX Lock.

If you forget the TX Lock password, please contact your Brother dealer for assistance.

Operation from an External or Extension Telephone

An external phone is a telephone that is plugged into your MFC (either into the MFC's EXT socket or into the back of the connector that plugs into the telephone wall socket).

An extension phone is another phone on the same phone number as your MFC, but plugged into a different telephone wall socket. For example, your MFC may be connected to a phone line in your study, and you may have another phone on the same line (and same phone number) in your kitchen. This feature enables you to answer the phone in the kitchen if it rings while you are making a coffee, knowing that you can transfer the call to your MFC if the incoming call is a fax.

If you answer a fax call on an external or extension phone, you can make your MFC take over by using the Activation Code. When you press the Activation Code * 5 1, the MFC starts to receive a fax.

If the MFC answers a voice call and F/T pseudo-rings for you to take over, use the Deactivation Code # 5 1 to take the call at an extension phone. The Deactivation Code is used only in Fax/Tel mode. (See *Setting the F/T (Fax/Tel) Ring Time (Fax/Tel Mode Only)* in Chapter 3.)

If you answer a call, and no one is on the line, assume you are receiving a fax. At the MFC phone, press **Start**, then hang up. At an extension phone, press * 5 1, wait for fax receiving tones (chirps), then hang up. At an external phone, press * 5 1 and wait for the phone to be disconnected (the screen displays **RECEIVE**) before you hang up. (Your caller will have to press Start to send the fax.)



If you accidentally pick up an extension phone when a fax message is being received, you may disrupt the transmission or render some portions unreadable.

The Remote Activation Code also can be used by your callers. When you are using an external TAD, your outgoing message (OGM) should end with the statement "to send a fax, press * 5 1". (See *Outgoing Message (OGM) of External TAD* in Preparation and Simple Use Guide.)

For Fax/Tel Mode Only

When the MFC is in F/T mode, it will use the F/T Ring Time (F/T pseudo-ringing) to alert you to a voice call. If you're at the machine, you can pick up the handset (for MFC-840) or lift the external telephone's handset and press **Tel** (for MFC-830) to answer.

If you are at an extension phone, you'll need to lift the handset during the F/T Ring Time and press # 5 1 between the F/T pseudo-rings. If no one is on the line, or if someone wants to send you a fax, send the call back to the MFC by pressing * 5 1.

Changing Remote Codes

Remote Codes might not work with some telephone systems. The preset Activation Code is * 5 1. The preset Deactivation Code is # 5 1.



If you are always disconnected when accessing your external TAD remotely, try changing the Activation Code from * 5 1 to ### and the Deactivation Code from # 5 1 to 1 1 1. You cannot use the same number for the Activation Code and the Deactivation Code.

To change Remote Codes

- 1 Press **Menu**, **1**, **2**, **4**.
- 2 Press ◀ or ▶ to select **ON** (or **OFF**), and press **Set** when the screen displays the setting you want.
- 3 If you want to, enter a new Remote Activation Code, then press **Set**.
- 4 If you want to, enter a new Remote Deactivation Code, then press **Set**.
- 5 Press **Stop** to exit.

Telephone Services

BT Call Sign (For U.K. Only)

This machine feature lets you use the BT Call Sign subscriber service which allows you to have at least two separate telephone numbers on one phone line. Each phone number has its own distinctive ringing pattern, so you know which phone number is ringing. This is one way you can have a separate phone number for your machine.

Your machine has a BT Call Sign compatible distinctive ringing function, allowing you to dedicate a second phone number (on the same phone line) just for receiving faxes.



You can switch it off temporarily, then turn it back on. When you get a new fax number, make sure you reset this function.



- To have your external TAD answer only the main number, the machine must be in Manual Mode.
- In FAX mode, the machine will answer all numbers on the phone line.

To enable the machine to work with BT Call Sign

- 1 Set the machine to **MANUAL** mode.
- 2 Press **Menu**, **1**, **0**, **1**. The screen displays the current setting of this feature.
- 3 Press ◀ or ▶ to select **ON** (or **OFF**).
- 4 Press **Set**.
- 5 Press **Stop** to exit.



Polling is the process of retrieving faxes from another machine. You can use your MFC to “poll” other machines, or you can have someone poll your MFC.

All parties involved in polling need to set up their machines to accommodate polling. When someone polls your MFC to receive a fax, they pay for the call; if you poll someone’s fax machine to receive a fax, you pay for the call. (See *Polling Transmit (Not Available for Colour Fax)* in this Chapter.)

Polling Receive

Secure Polling

Secure Polling is a way to keep your documents and others’ from falling into the wrong hands while the MFC is set up for polling. You can use Secure Polling only with another Brother fax machine. Your four-digit ID number must be entered on the fax machine that polls for your documents.



Some machines do not respond to the polling function.

Setup for Polling Receive

Polling Receive is when you call another fax machine to receive a fax from it.

- 1 Press **Menu, 1, 2, 7**. The screen displays
- 2 Press **◀** or **▶** to choose **STANDARD**, and press **Set**.
The screen prompts you to enter the fax number you want to poll, and then to press **Start**.
- 3 Enter the fax number you are polling, and press **Start**.
The screen displays **DIALING #XX**.



Setup for Polling Receive with Secure Code

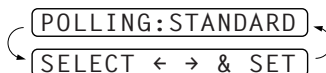

You need to make sure you are using the same ID number as the other party.

- 1 Press **Menu, 1, 2, 7**. The screen displays
- 2 Press **◀** or **▶** to choose **SECURE**, and press **Set**.
- 3 Enter a four-digit number.
This is the same as the security code of the fax machine you are polling.
- 4 Press **Set**.
The screen prompts you to enter the fax number you want to poll, and then to press **Start**.
- 5 Enter the fax number you are polling.
- 6 Press **Start**.

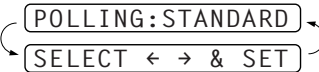

Setup Delayed Polling Receive

You can set your MFC to begin Polling Receive at a later time.

- 1 Press **Menu, 1, 2, 7**. The screen displays 
- 2 Press **<** or **>** to choose **TIMER**, and press **Set**.
- 3 The screen prompts you to enter the time you want to begin polling.
- 4 Enter the time (in 24-hour format) you want to begin polling.
For example, enter 21:45 for 9:45 PM.
- 5 Press **Set**. The screen prompts you to enter the fax number you are polling and then to press **Start**.
- 6 Enter the fax number, and press **Start**.
The MFC makes the polling call at the time you entered. 



You can set up only one Delayed Polling.

Sequential Polling

Your MFC can request documents from several fax units in a single operation. You just specify several destinations in Step 4. Afterwards, a Sequential Polling Report will be printed.

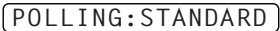
- 1 Press **Menu, 1, 2, 7**. The screen displays 
- 2 Press **<** or **>** to choose **STANDARD, SECURE** or **TIMER**, and press **Set** when the screen displays the setting you want.
- 3 If you selected **STANDARD**, the screen prompts you to enter the fax number you want to poll, and then to press **Start**.
 - If you selected **SECURE**, enter a four-digit number and press **Set**.
 - If you selected **TIMER**, enter the time (in 24-hour format) you want to begin polling and press **Set**.
- 4 Specify the destination fax machines, which you wish to poll by using One Touch, Speed Dial, a Group, Tel-Index or the dial pad. You must press **Set** between each location.
- 5 Press **Start**.
Your MFC polls each number or group number in turn for a document.

Polling Transmit (Not Available for Colour Fax)

Polling Transmit is when you set up your MFC to wait with a document so another fax machine can retrieve it.

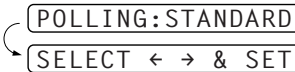
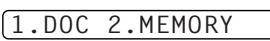
- 1 Place document to be retrieved in feeder.
- 2 Press **Menu, 1, 3, 8**. The screen displays 
- 3 Press **<** or **>** to choose **STANDARD**, and press **Set**. The screen displays 
- 4 Press **1** to select **DOC** if you want your MFC to scan the printed document at the time it is polled—**OR**—Press **2** to select **MEMORY**.
- 5 Press **1** if you want to select additional settings. The display returns to the **SETUP SEND** menu—**OR**—Press **2** if you choosing setting and go to Step 8.
- 6 Press **Start**.

Setup for Polling Transmit with Secure Code

When you set **POLLING:SECURE** to on, anyone who polls your MFC must enter the polling ID number.

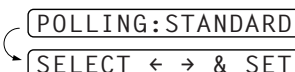
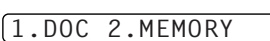
- 1 Place document in feeder.
- 2 Press **Menu, 1, 3, 8**. The screen displays 
- 3 Press **<** or **>** to choose **SECURE**.
- 4 Enter a four-digit number, and press **Set**.
- 5 Press **1** to select **DOC** if you want your MFC to scan the printed document as it is polled—**OR**—Press **2** to select **MEMORY**. 
- 6 Press **1** if you want to select additional settings. The display returns to the **SETUP SEND** menu—**OR**—Press **2** if you are finished choosing settings and go to Step 7.
- 7 Press **Start** and wait for the fax to be polled.



You can use Secure Polling only with another Brother fax machine.

Cancelling a Job While Scanning the Document

You can cancel a job while you are scanning it into memory by pressing **Stop**. Eject the document by pressing **Stop** again.

Checking Job Status

You can check which jobs are in memory waiting to be sent. Press **Menu, 1, 4** to check it. While the MFC is sending or receiving a fax, press **Stop**. The screen display job numbers. Press **<** or **>** to see them.

Fax Forwarding



You cannot use Fax Forwarding when "Fax Storage" is set to **OFF**.

Setting Fax Storage

If you set Fax Storage to **ON**, you will be able to retrieve fax messages from another location, using Fax Forwarding or Remote Retrieval functions. The screen will indicate when you have a fax stored in memory. Fax storage only works with black and white fax messages. It is not possible to receive colour faxes with fax storage function switched to **ON**.

- 1 Press **Menu**, **1**, **7**, **2**. The screen prompts you to choose a fax setting.
- 2 Press **◀** or **▶** to select **ON** (or **OFF**), and press **Set** when the screen displays your selection.
- 3 Press **Stop** to exit.



If there are faxes in memory when you turn the Fax Storage **OFF**, the screen prompts you to erase any faxes in memory.

If you press **1**, all fax data is erased and Fax Storage is turned **OFF**. If the fax data in memory has not been printed before, it will be printed first, and then erased. If you press **2**, data is not erased, and Fax Storage remains **ON**.

Programming a Fax Forwarding Number

When Fax Forwarding is set to **ON**, your fax machine stores the received fax in memory, then dials the fax machine phone number you've programmed, and forwards the fax message. (See *Changing the Fax Forwarding Number* in this Chapter.)

- 1 Press **Menu**, **1**, **7**, **1**.
- 2 Press **◀** or **▶** to select **ON** (or **OFF**), and press **Set**.
The screen prompts you to enter the number of the fax machine where faxes will be forwarded.
- 3 Enter the forwarding number (up to 20 digits), and press **Set**.
- 4 Press **Stop** to exit.

Remote Retrieval

You can also dial into your machine from a remote location to switch this feature on, or to change the number you want your faxes forwarding to.

Changing the Remote Access Code

Enter your Remote Access Code when the fax machine picks up your call, so you can access features remotely. The access code is preset to 1 5 9 *, but you can change this.

- 1 Press **Menu, 1, 7, 3**.
- 2 Enter a three-digit number from 000 to 998, and press **Set**.
The * cannot be changed. Do not use the same digits that appear in your Remote Activation or Deactivation Code.
- 3 Press **Stop** to exit.

Using Your Remote Access Code

To receive faxes at your location, you must call from a fax machine using touch tone. For convenience, you can retrieve faxes from a touch tone phone by having them sent to a fax machine. For example, if your hotel room does not have a fax machine, you can enter the number of the fax machine at the hotel's Front Desk.

- 1 Dial your fax number from a touch tone phone.
- 2 When your fax machine answers and beeps, immediately enter your Remote Access Code (The factory setting is 1 5 9 *).
- 3 The fax machine signals the kinds of messages received:
1 long beep — Fax message(s)
No long beep — No messages
- 4 The fax machine prompts you with two short beeps to enter a command. If you wait longer than 30 seconds to enter a command, the machine hangs up. If you enter an invalid command, the machine beeps three times.
- 5 Press **9 0** to reset the machine when you finish.
- 6 Hang up.

Remote Commands

Follow the commands below to access features remotely. When you call the fax machine and enter your Remote Access Code (The factory setting is 1 5 9 *), the system will signal you with two short beeps to enter a remote control command.

Change Fax Forwarding Setting

Press **9 5**

then to

Turn Fax Forwarding OFF—Press **1**.

Turn Fax Forwarding ON—Press **2**.

Program Fax Forward Number—Press **4**. Automatically turn on Fax Forwarding **ON**.

Turn Fax Storage ON—Press **6**.

Turn Fax Storage OFF—Press **7**. (This is only possible if there are no faxes stored in the memory, or if all faxes have been erased using Remote Control **9 6 3**).

Retrieve a Fax

Press **9 6**

then to

Retrieve a Memory Status List—Press **1**, then enter the number of remote fax machine and then press **# #**. After the beep, hang up and wait.

Retrieve all faxes—Press **2**, then enter the number of remote fax machine and then press **# #**. After the beep, hang up and wait.

Erase all fax messages—Press **3**. If the data stored in the memory has not been printed before, it will be printed first and then erased.

Check the Receiving Status

Press **9 7**

then for

Fax messages—Press **1**.

1 long beep — Received messages.

3 short beeps — No messages.

Change Receive Mode

Press **9 8**

then for

TAD—Press **1**.

Fax/Tel (F/T)—Press **2**.

Fax—Press **3**.

Exit Remote Operation

Press **9 0**

Retrieving the Memory Status List

You can retrieve the Memory Status List from a remote fax machine to see if you have any fax messages.

- 1 Dial your fax machine's number.
- 2 When you hear the beep, immediately enter your Remote Access Code (the factory setting is 1 5 9 *).
- 3 When you hear two short beeps, use the dial pad to press **9 6 1**.
- 4 Using the dial pad, enter the number (up to 20 digits) of the remote fax machine where you want the Memory Status List forwarded, and then press **# #**.



You cannot use * and # as dial numbers. However, if you want to store a pause, press #.

- 5 After you hear your fax machine beep, hang up and wait.
Your fax machine calls the remote fax machine. Your fax machine then sends the Memory Status List to the fax machine that you are calling from.

Retrieving Fax Messages

- 1 Dial your fax machine's number.
- 2 When you hear the beep, immediately enter your Remote Access Code (the factory setting is 1 5 9 *).
- 3 As soon as you hear two short beeps, use the dial pad to press **9 6 2**.
- 4 Using the dial pad, enter the number (up to 20 digits) of the remote fax machine where you want your fax messages forwarded, and then press **# #**.



You cannot use * and # as dial numbers. However, if you want to store a pause, press #.

- 5 After you hear your fax machine beep, hang up and wait.
Your fax machine calls the remote fax machine. The fax machine that you are calling from prints your fax messages.

Changing the Fax Forwarding Number

You can change the default setting of your fax forwarding number from a remote fax machine.

- 1 Dial your fax machine's number.
- 2 When you hear the beep, immediately enter your Remote Access Code (the factory setting is 1 5 9 *).
- 3 When you hear two short beeps, use the dial pad to press **9 5 4**.
- 4 Enter the new number of the remote fax machine where you want your fax messages forwarded, and then press **# #**.



You cannot use * and # as dial numbers. However, if you want to store a pause, press #. Also, if your fax machine is connected to a PABX, you can press # first before the fax machine's number. The # works as well as R key.

- 5 To retrieve the Memory Status List, when you hear two short beeps, use the dial pad to press **9 6 1**.
- 6 Use the dial pad to enter the number of the remote fax machine (up to 20 digits), and then press **# #**.
- 7 After you hear your fax machine beep, hang up and wait.
Your fax machine calls the remote fax machine. Your fax machine then sends the Memory Status List showing the new forwarding number to the fax machine that you are calling from.
- 8 Check the forwarding number.
If the forwarding number is incorrect, return to Step 1 to reset it.

10 Making Copies

Basic Copy Operations

Making a Copy

Your Multi-Function Centre allows you to make high-quality photocopies and transparencies. Copies can be in black and white, one colour, or full colour. Always make sure you have paper in the cassette before making copies.

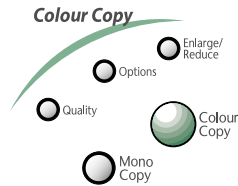

Do NOT pull on the paper while copying is in progress. To cancel, press Stop.

Making a Single Copy

- 1 Place the document face down in the feeder.
- 2 Press **Mono Copy** or **Colour Copy** to copy.
- 3 Press **Mono Copy** or **Colour Copy** again. (Make sure it's the same key you pressed in Step 2.)
- 4 To stop, press **Stop** to release the original document.

COPYING P.01

Making Multiple Copies

You can make multiple copies in black and white or one colour using your MFC.

- 1 Place the document face down in the feeder.
- 2 Press **Mono Copy** or **Colour Copy**.
- 3 Using the dial pad, enter the number of copies you want.
For example, press **3, 8** for 38 copies.
- 4 Press **Mono Copy** or **Colour Copy**.

NOTE: You must press the same button you pressed in Step 2.



To sort copies, see Using the **Options** Key in this chapter.
After you press **Mono Copy** or **Colour Copy**, you can use the **Enlarge/Reduce**, **Quality** and **Options** keys to try different combinations of settings for best results.

Memory Full Message

If the memory becomes full while you're making copies, the screen displays

MEMORY FULL P.02

followed by

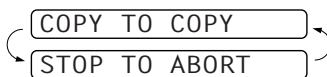

If you were scanning the first page of your document, press **Stop** to cancel the job and restart to make a single copy. If you were scanning a subsequent page, press **Mono Copy** or **Colour Copy** to print the pages already scanned—**OR**—Press **Stop** to cancel.

You'll need to clear some fax messages to make some additional memory available before you can continue.



To gain extra memory, you can turn off Fax Storage in Chapter 9—**OR**—Print fax messages in memory in Chapter 3.

Temporary Copy Setting

You can quickly improve the copy quality by using the **Enlarge/Reduce**, **Quality** and **Options** keys. These settings are temporary, and the MFC returns to its default settings when you finish copying. You might want to try different combinations of settings to see which best suits your needs.



After you press **Mono Copy** or **Colour Copy**, you can use **Enlarge/Reduce**, **Quality** and **Options** to try different combinations of settings for best results.

Making Enlarged or Reduced Copies (Temporary Setting)

1 Insert the document face down in the feeder.

2 Press **Enlarge/Reduce**. The screen displays

3 Press ◀ or ▶ to choose an enlargement or reduction ratio.

You can reduce to **93%**, **87%**, **75%**, **50%** or **25%** of the original size

—**OR**—

You can enlarge to **120%**, **125%**, **150%**, **200%** or **400%**

—**OR**—

You can select **MANUAL** and press **Set**, then use the dial pad to enter an enlargement or reduction ratio between **25%** and **400%**. For example, press **5, 3** to enter **53%**.

4 Press **Set**.

5 Press **Mono Copy** or **Colour Copy**.

6 Using the dial pad, enter the number of copies—**OR**—Keep the default (01).

7 Press **Set**.

ELG/RDC: 100%

THEN COPY OR SET

Using the Quality Key

The **Quality** key changes the settings for quality (**DRAFT**, **NORMAL**, **HIGH** or **PHOTO**).

- DRAFT:** Fast copy speed and lowest ink consumption. Use DRAFT to save time (documents to be proof-read, large documents, or many copies).
- NORMAL:** Recommended mode for ordinary printouts. Good copy quality with adequate copy speed.
- HIGH:** Better copy quality than normal and faster copy speed than PHOTO.
- PHOTO:** Use this mode to copy precise images such as photographs. PHOTO uses the highest resolution and slowest speed.

- 1 Place the document to be copied in the feeder.
- 2 Press **Quality**. The screen displays the default setting.
- 3 Press ◀ or ▶ to select copy quality resolution.
QUALITY:NORMAL
QUALITY:HIGH
QUALITY:DRAFT
QUALITY:PHOTO
- 4 When the screen displays your selection, press **Set**.

Using the Options Key

The **Options** key changes the settings for paper type, brightness and special copy options **for the next fax only**. These options will be displayed in the order of the chart below.

Press **Options**.

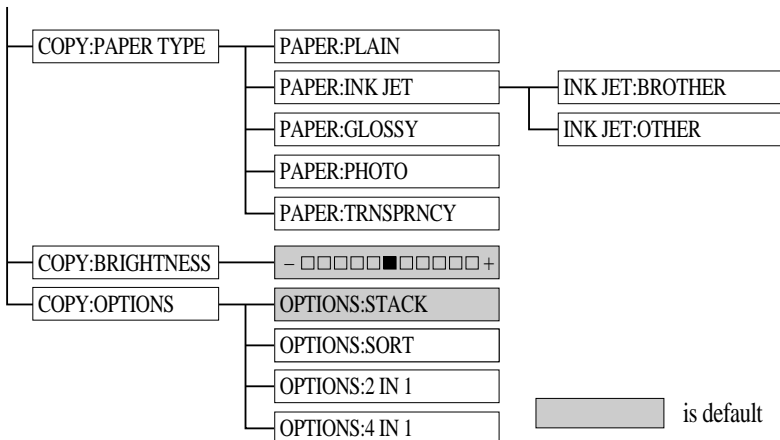

- 1 Place the original face down in the ADF.
- 2 Press **Options**.

- 3** Press ◀ or ▶ to select **COPY:PAPER TYPE**, **COPY:BRIGHTNESS**, or **COPY:OPTIONS**, and press **Set**.

If you selected the **COPY:PAPER TYPE**:



If you use premium paper, the copy quality will be improved. For best results, we recommend using Brother special paper.

- 4** Press ◀ or ▶ to select the type of paper you are using (**PLAIN**, **INKJET**, **GLOSSY**, **PHOTO** or **TRNSPRNCY**), and press **Set**.



Brother coated paper is ink jet paper.



If you are using non-Brother ink jet paper or Brother coated paper, select **INK JET**.

If you selected **INK JET**:

- 5** Press ◀ or ▶ to select **BROTHER** (BP72CA) or **OTHER** (non-Brother ink jet) paper type, and press **Set**.

To select **COPY:BRIGHTNESS**:

- 6** Repeat Step 3.

- 7** Press ◀ to make a lighter copy—**OR**—press ▶ to make a darker copy, and press **Set**.

To select special **COPY:OPTIONS**:

- 8** Repeat Step 3.

- 9** Press ◀ or ▶ to select **STACK**, **SORT**, **2 IN 1** or **4 IN 1**, and press **Set**.

2 in 1

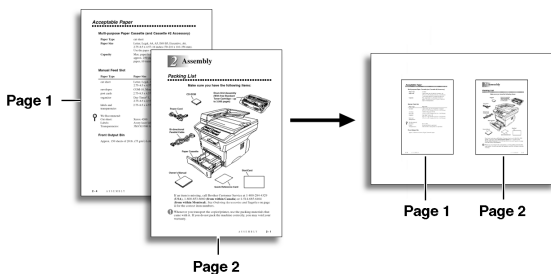

4 in 1

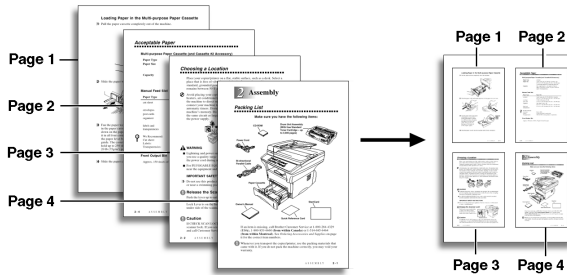

SORT, 2in1 or 4in1 print in black and white.

10 Press **Mono Copy** or **Colour Copy**.

11 Using the dial pad, enter the number of copies you want.
For example, press **3, 8** for 38 copies.

12 Press **Mono Copy** or **Colour Copy**.

Copy Quality – Default Settings

Changing Default Settings

Press **Menu, 3** to change default settings for Copy mode. These settings will remain until you change them again by pressing **Menu**. Adjust the colours using the Colour Adjustment, and Contrast settings.

By pressing a number, you can adjust copy settings as shown in the following chart. Press ◀ or ▶ to move through the selections for each setting. Press **Set** to save your selection. Press **Stop** to exit—**OR**—Press ▶ to select the next setting you want to change.

Press **Menu** and **3**.

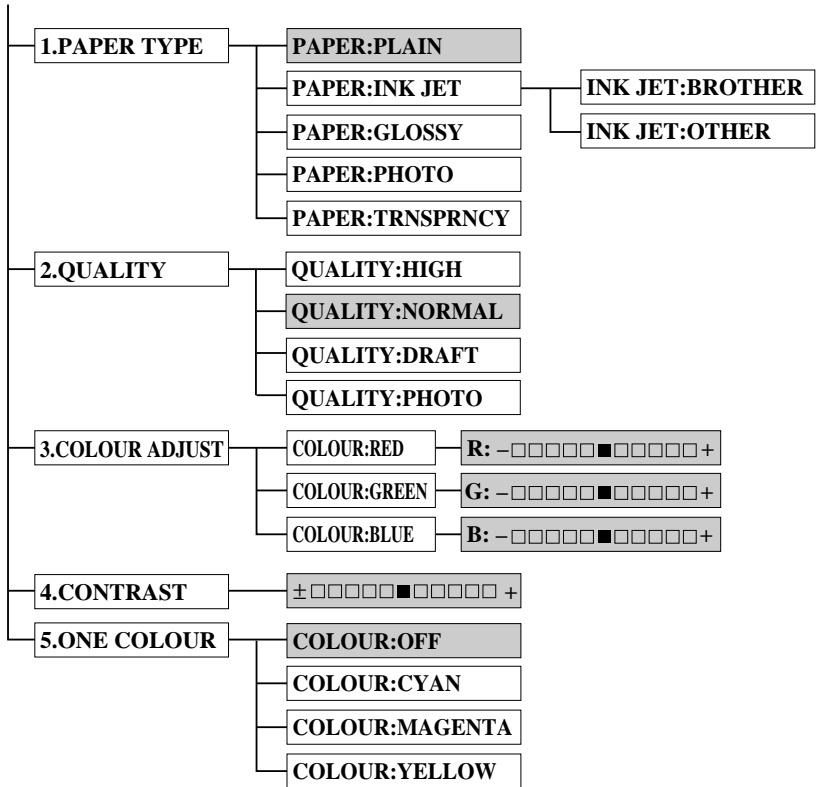

 : is default

Select Paper Type

1 Press **Menu, 3, 1**. The screen displays

1. PAPER TYPE

2 Press **Set**.

3 Press **◀** or **▶** to select your paper setting.

4 Press **Set** when the screen displays your selection.

If you use Brother coated paper, select **INK JET**, then select **BROTHER** (BP72CA). If you use non-Brother ink jet paper, select **INK JET**, then select **OTHER**. If you did not select **INK JET**, skip to Step 6. (For information on ordering Brother paper, see the page before the Table of Contents.)

5 Press **◀** or **▶** to select **BROTHER** or **OTHER**, and press **Set**.

6 Press **Stop** to exit.



The MFC ejects paper with printed surfaces face up into the paper tray at the front of the MFC. When you use transparencies, remove each sheet immediately, to prevent a paper jam or curled sheets.

Select Copy Quality

1 Press **Menu, 3, 2**.

2 Press **◀** or **▶** to select copy quality and press **Set** when the screen displays your selection.

3 Press **Stop** to exit.

Colour Adjustment

1 Press **Menu, 3, 3**.

2 Press **◀** or **▶** to select **RED**, **GREEN**, or **BLUE**, and press **Set**.

Light Dark

R: -□□□□□■□□□□□+

G: -□□□□□■□□□□□+

B: -□□□□□■□□□□□+

3 Press **◀** or **▶** to adjust the degree of colour, and press **Set**.

4 Return to Step 2 to select the next colour—**OR**—Press **Stop** to exit.

Copy Contrast

You can choose the contrast setting for a copy. Greater contrast can help an image look sharper and more vivid. This feature is available only for colour copying.

1 Press **Menu, 3, 4**.

2 Press **◀** to decrease contrast—**OR**—Press **▶** to increase contrast.
Press **Set** when the screen displays your setting.

3 Press **Stop** to exit.

Selecting a Single Colour (One Colour)

For black and white originals, you can select a single colour, instead of black, as the default to be used when you press **Mono Copy**. **OFF** is the default setting for Black printing.

- 1 Press **Menu**, **3**, **5**.
- 2 Press **◀** or **▶** to select a copy colour: The options are OFF, CYAN, MAGENTA, and YELLOW.
- 3 Press **Set** when the screen displays your selection.
- 4 Press **Stop** to exit.

Legal Limitations

Colour reproductions of certain documents are illegal and may result in either criminal or civil liability. This Notice is intended to be a guide rather than a complete listing of every possible prohibition. In case of doubt we suggest that you consult with the legal authorities in your individual country as to the legality of any particular questionable documents.

The following are examples of documents which should not be copied:

- Paper money.
- Bonds or other certificates of indebtedness.
- Certificates of Deposit.
- Armed Forces Service or Draft papers.
- Passports.
- Postage stamps (cancelled or uncanceled).
- Immigration papers.
- Welfare documents.
- Cheques or Drafts drawn by Governmental Agencies.
- Identification Documents, badges or insignias.
- Licences and Certificates of Title to motor vehicles.

Copyrighted works cannot be copied: however, sections of a copyrighted work can be copied for “personal use”. Multiple copies would indicate improper use.

Works of art should be considered the equivalent of copyrighted works.

11 Walk-Up Video Printing

Walk-Up Video Printing lets you use your MFC, connected to your camcorder, digital camera, video game, or VCR, to view a video on the attached equipment. The input is compatible with PAL video signal only.

Getting Started

With no documents in the feeder, plug the cable from your video camera's Video Out jack into the MFC's RCA pin jack. Play the video.

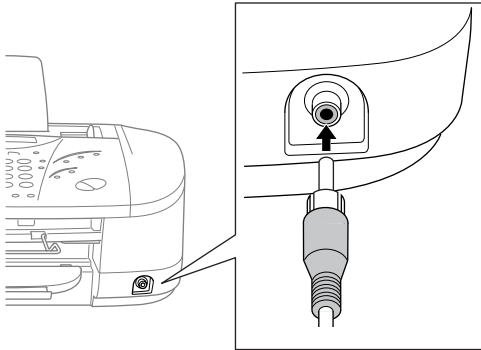

Some camcorders, digital cameras, video games or VCRs do not **correctly** conform with PAL standards. If they are not 100% PAL compatible then printing problems may be experienced.

Auto Switch

Whenever you connect video equipment to the MFC and turn the video signal on, the MFC **Copy** keys automatically switch to video printing mode

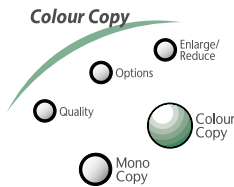

and the screen displays



As soon as you turn off the video equipment or disconnect it, the Colour Copy keys return to normal copy mode. You cannot access video printing mode if you have too much in memory. Print the documents in the memory.

Colour Video Printing

- 1 With no documents in the feeder, plug the cable from your video camera's Video Out jack into the MFC's RCA pin jack.
- 2 Play the video. When the MFC begins receiving the video signals, the MFC screen displays
- 3 Press **Colour Copy** when you see the picture you want to capture and print. The MFC begins printing, and beeps when printing is complete.



If the MFC is not receiving video signals, **Colour Copy** will not work. However, if there is a document in the feeder, the MFC will print a colour copy of the document.

Black & White Video Printing

For Black and white video printing, follow the steps for Colour Video Printing, using **Mono Copy** instead of **Colour Copy**.

Temporary Video Print Setting

You can quickly improve the copy quality of video printouts by using the **Quality** key and **Options** key. These settings are temporary, and the MFC returns to its default settings when you finish printing. You might want to try different combinations of settings to see which best suits your needs.

Using the Quality Key

Your MFC allows you to customize the quality of your video copies by letting you select the video print quality and paper type. You might want to try different combinations of settings to see which best suits your needs. The settings are temporary.

- 1 **Make sure there is no document in the feeder.** Plug the cable from your video camera's Out jack into the MFC's RCA pin jack.
- 2 Press **Quality**. The screen displays the current setting.
- 3 Use ◀ or ▶ to select copy quality.
QUALITY:NORMAL
QUALITY:HIGH



If there is too much in memory, the print quality will be reduced.

- 4 When the screen displays your selection, press **Set**.
The screen displays
- 5 Press **Mono Copy** or **Colour Copy**.
The screen shows

PRESS COPY KEY

PRINTING

Using the Options Key

The **Options** key changes the settings for paper type, video type, print size, quality and brightness *for the next video printing only*. These options will be displayed in the order of the chart below.

Press **Options**.

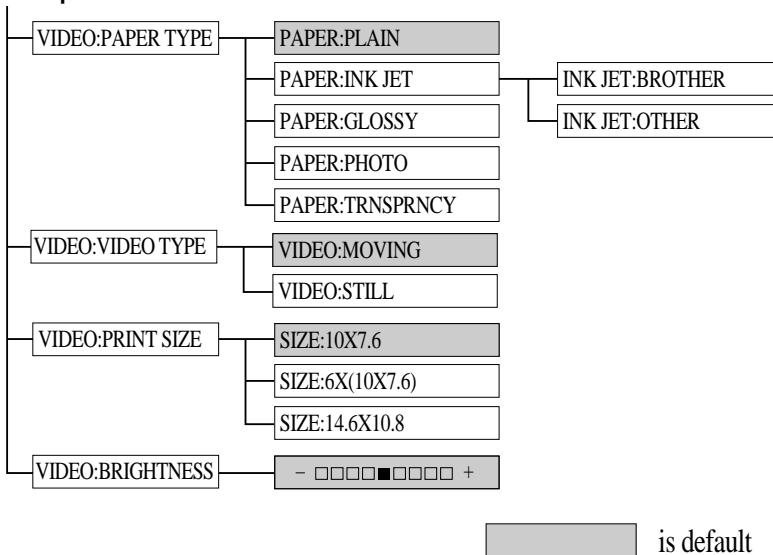

- 1 Make sure the ADF is empty. Plug the cable from your video camera's Out jack into the MFC's RCA pin jack.
- 2 Press **Options**.
- 3 Press **◀** or **▶** to select **VIDEO: PAPER TYPE**, **VIDEO: VIDEO TYPE**, **VIDEO: PRINT SIZE**, or **VIDEO: BRIGHTNESS** and press **Set**.

If you selected the **VIDEO: PAPER TYPE**:



If you use premium paper, the copy quality will be improved. For best results, we recommend using Brother special paper.

- 4 Press **◀** or **▶** to select paper type you are using (**PLAIN**, **INK JET**, **GLOSSY**, **PHOTO** or **TRNSPRNCY**), and press **Set**.



Brother coated paper is ink jet paper.



If you are using non-Brother ink jet paper or Brother coated paper, select **INK JET**.

If you selected **INK JET**:

- 5 Press ◀ or ▶ to select **BROTHER** (BP72CA) or **OTHER** (non-Brother ink jet) paper type, and press **Set**.

To select **VIDEO:VIDEO TYPE**:

- 6 Repeat Step 3.
- 7 Press ◀ or ▶ to select **MOVING** or **STILL**, and press **Set**.

To select **VIDEO:PRINT SIZE**:

- 8 Repeat Step 3.
- 9 Press ◀ or ▶ to select **14.6X10.8**, **10X7.6** or **6X(10X7.6)**, and press **Set**.

To select **VIDEO:BRIGHTNESS**:

- 10 Repeat Step 3.
- 11 Press ◀ to make a lighter copy—**OR**—press ▶ to make a darker copy, and press **Set**.
- 12 Press **Mono Copy** or **Colour Copy**.
- 13 Using the dial pad, enter the number of copies you want.
For example, press **3, 8** for 38 copies.
- 14 Press **Mono Copy** or **Colour Copy**.

Changing Default Settings

Press **Menu** and **4** to change default settings for video printing.

By pressing **Menu**, **4** and a number, you can adjust video printing settings as shown in the following chart. Press ◀ or ▶ to move through the selection for each setting. Press **Set** to save your selection.

Press **Menu** and **4**.

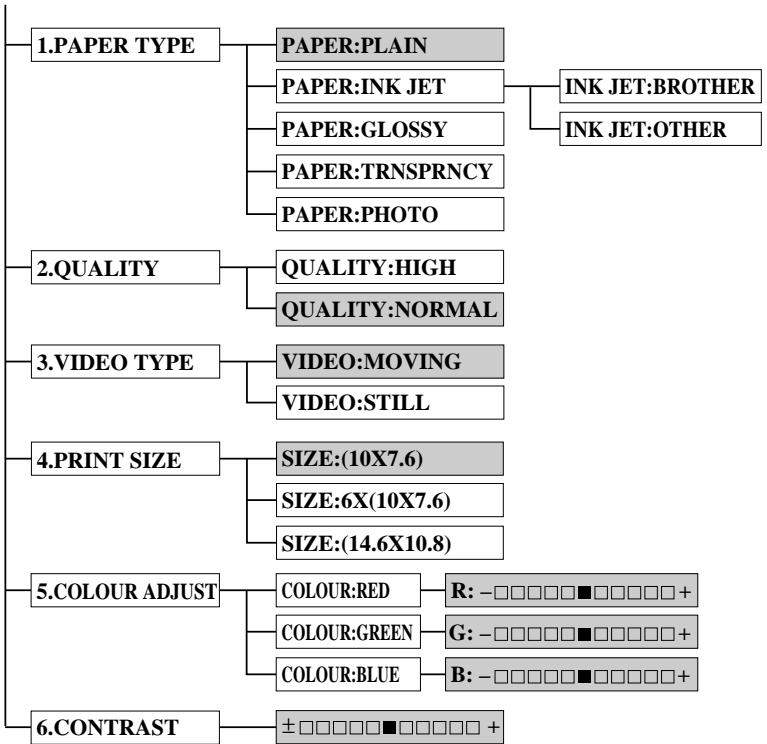

 is default

Setting Paper Type

- 1 Press **Menu**, **4**, **1**.
- 2 The screen displays
PAPER:PLAIN
PAPER:INK JET
PAPER:GLOSSY
PAPER:TRNSPRNCY
PAPER:PHOTO
- 3 Press **◀** or **▶** to select a paper type, and press **Set** when the screen displays your selection.
If you are using Brother coated paper, select **INK JET**, then select **BROTHER** (BP72CA).
If you are using non-Brother ink jet paper, select **OTHER**.
- 4 Press **Stop** to exit.

Setting Video Printing Quality

- 1 Press **Menu**, **4**, **2**. The screen displays **2. QUALITY**.
- 2 Press **◀** or **▶** to select a quality.
QUALITY:NORMAL
QUALITY:HIGH
- 3 Press **Set** when the screen displays your selection.
- 4 Press **Stop** to exit.

Setting Video Type

Before you turn on the video signal, you must set the MFC to receive either a moving or a still image. You can watch the video play on the video camera and press **Mono Copy** or **Colour Copy** when you see the frame you want to print.

- 1 Press **Menu**, **4**, **3**.
- 2 Press **◀** or **▶** to select video type, and press **Set** when the screen displays your selection.
- 3 Press **Stop** to exit.



If you don't have enough memory to process the selected video image, the print quality may be poor even for a still frame.

Setting Print Size

- 1 Press **Menu**, **4**, **4**.
- 2 Press **◀** or **▶** to select print size:
SIZE: (14.6 X 10.8)
SIZE: (10 X 7.6)
SIZE: 6 X (10 X 7.6)
- 3 Press **Set** when the screen displays your selection.
- 4 Press **Stop** to exit.

Printed Position

① 14.6cm x 10.8cm
(5.75" x 4.25")

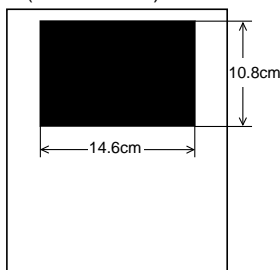

② 10cm x 7.6cm
(4" x 3")

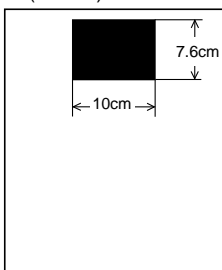

③ 6 x (10cm x 7.6cm)
(6 x (4" x 3"))

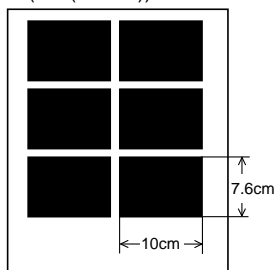

Video Printing Colour Adjustment

- 1 Press **Menu**, **4**, **5**.
- 2 Press ◀ or ▶ to select **RED**, **GREEN**, or **BLUE**, and press **Set**.

Light Dark

R: -□□□□□■□□□□□+

G: -□□□□□■□□□□□+

B: -□□□□□■□□□□□+

- 3 Press ◀ or ▶ to adjust the degree of colour, and press **Set**.
- 4 Return to Step 2 to select the next colour—**OR**—Press **Stop** to exit.

Video Printing Contrast

You can choose contrast setting before making a copy.

- 1 Press **Menu**, **4**, **6**.
- 2 Press ◀ to decrease contrast—**OR**—Press ▶ to increase contrast, and press **Set** when the screen displays your setting.
- 3 Press **Stop** to exit.

-□□□□□■□□□□□+

General Description

Your Brother MFC includes two media drives for use with popular digital camera media: Compact Flash™ and SmartMedia™. The PhotoCapture Centre™ feature of your MFC enables you to print digital photos from your digital camera at high resolution for photo quality printing. You can also print colour video frames from VCR, camcorder or digital camera using standard PAL video port connection.

This unique feature of your Brother MFC allows you to capture video frames to be stored on your PC, as well as to print, fax, save or integrate images into other files quickly and easily.

Getting Started

- 1 Insert the media card into the media drive (PhotoCapture Centre™).



Please note that there are two slots on your MFC, one is for a CompactFlash™ card, and the other is for a SmartMedia™ card. Please note to use the media cards for 3.3 volts only.



The top slot is for a CompactFlash™ Card, the bottom is for a SmartMedia™ Card. Insert the card by positioning the top of the card pointing to the left. Firmly insert the card into the appropriate slot.

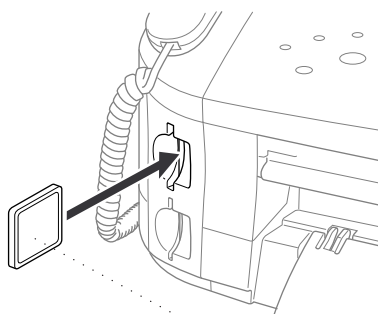

For Compact Flash™ card

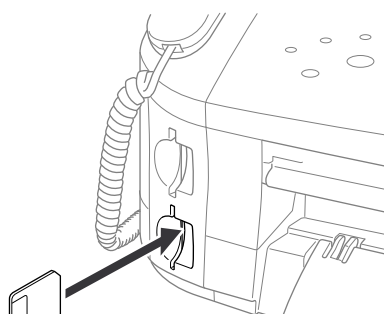

For SmartMedia™ Card

Media Card Indicator Lights:

- **LED** light is on when the media card is inserted properly.
- If **LED** is not on, the media card is not properly inserted.
- If **LED** is blinking, the media card is being read or written.



Do not unplug the power cord or remove the SmartMedia™ or CompactFlash™ card from the PhotoCapture Centre™ while the MFC is reading the card (LED is flashing), you can loose your data or damage the card.



If both media cards are inserted at the same time, the PhotoCapture Centre™ (will only read the card that was installed first.



To have access to the other card, you must first remove both cards, then insert only the media card.

User settings are kept until the media card is removed.

DPOF Printing

DPOF stands for Digital Print Order Format. Major Digital Camera manufacturers (Canon Inc, Eastman Kodak Company, Fuji Photo Film Co., Ltd. and Matsushita Electric Industrial Co., Ltd.) created this standard to make it easier to print images from a digital camera.

If your digital camera supports DPOF printing, you will be able to select on the Digital Camera display the images and number of copies you wish to print. When the memory card (CompactFlash™ or SmartMedia™) with DPOF information is inserted into your Brother MFC, the images you selected will be printed automatically.

- 1 Insert your media card into the appropriate slot.

The LCD shows:

S MEDIA ACTIVE

PRESS COLOUR CPY

If there a DPOF file on the card,

The LCD shows:

DPOF PRINT: YES?

SELECT ← → & SET



You can use the Quality key to adjust the quality of your output. if you want to change the settings for paper type, print size and colour enhancement, press **Options**. (See *Using the Options Key* in this Chapter.)

- 2 Press ◀ or ▶ to select **DPOF PRINT: YES?** and press **Set**.

The LCD shows:

—OR—

PRINTING

If you want to print an Index (thumbnails) or choose the images and their print option now, select **DPOF PRINT:NO?** and press **Set**.

(For details, see *Insert your media card into the appropriate slot.* below and *Printing Images* in this Chapter.)

Printing the index (Thumbnails)

The PhotoCapture Centre™ assigns numbers for images (ie. 001, 002, 003, etc.) It does not recognize any other numbers or files names that your digital camera or PC have used to identify the pictures. You can print a thumbnail page (Index) that shows all the pictures on the media card. Or, you can select only the images you want to print and use the **Options** key to select paper type, print size and colour enhancement.

The LCD shows:

- 1 Press **Colour Copy**.

The LCD shows:

- 2 Press **1** to print the Index (thumbnails) of all the images on your media card.

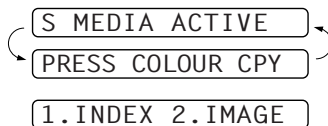

1. INDEX 2. IMAGE

Printing Images

The LCD shows:

- 1 Press **Colour Copy** to select whether you want to print a thumbnail page, or the images from your media card.
- 2 Press **2** to select individual images.
- 3 Enter the image number. You can select more than one image at the same time:

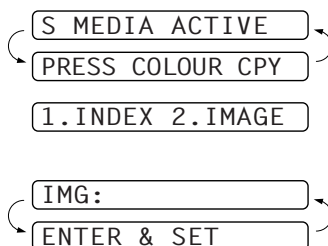

1. INDEX 2. IMAGE

IMG:
ENTER & SET

Press ***** for comma, (**1*3*6** - meaning image 1, 3 and 6),
Press **#** to print in sequence (**1#5** - meaning images 1 through 5).
You can press **Quality** to adjust the quality of your output.
(Default setting)

Press **◀** or **▶** to select the copy quality:

- 4 If you want to change the paper type, print size or colour enhancement, press **Options**.
(See *Using the Options Key* in this Chapter.)
—OR—

If you are ready to print, press **Colour Copy**.

- 5 Enter the number of copies you want, then press **Colour Copy** again.

QUALITY : NORMAL
THEN COPY OR SET
QUALITY : NORMAL
QUALITY : HIGH
QUALITY : PHOTO

PAPER TYPE
SELECT : < > & SET
NO. OF COPIES : 01
ENTER & COPY KEY

Using the Options Key

The **Options** key changes the settings for paper type, print size and colour enhancement. These options will be displayed in the order of the chart below.

Press **Options**.

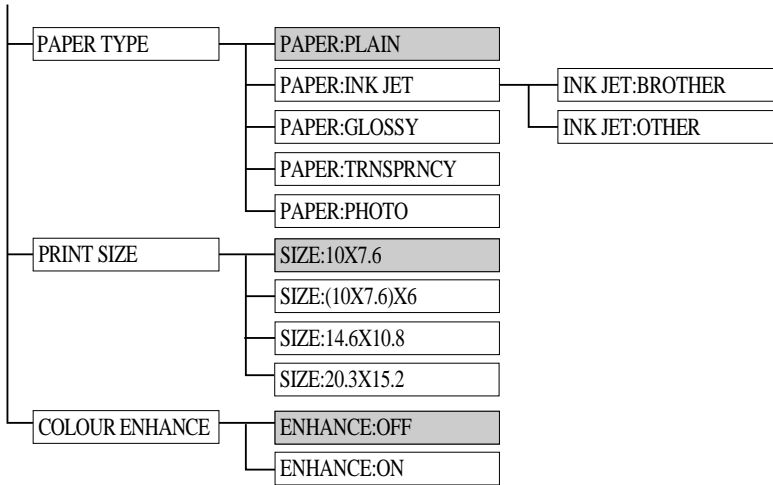

 is default

1 Press **Options**.

2 Press ◀ or ▶ to select **PAPER TYPE**, **PRINT SIZE** or **COLOUR ENHANCE**, and press **Set**.

If you selected the **PAPER TYPE**:



If you use premium paper, the copy quality will be improved. For best results, we recommended using Brother specials paper.

3 Press ◀ or ▶ to select the type of paper you are using (**PLAIN**, **INK JET**, **GLOSSY**, **PHOTO** or **TRNSPRNCY**), and press **Set**.



Brother coated paper is ink jet paper.



If you are using non-Brother ink jet paper or Brother coated paper select **INK JET**.

If you selected **INK JET**:

- 4 Press ◀ or ▶ to select **BROTHER** (BP72CA) or **OTHER** (non-Brother ink jet) paper type, and press **Set**.

To select **PRINT SIZE**:

- 5 Repeat Step 3.
- 6 Press ◀ or ▶ to select **14.6x10.8**, **10x7.6**, **(10x7.6)x6** or **20.3x15.2** and press **Set**.

To select **COLOUR ENHANCE**:

- 7 Repeat Step 3.
- 8 Press ◀ or ▶ to select **ENHANCE:ON** or **ENHANCE:OFF**, and press **Set**.

The MFC allows you to customize the colour enhance is set by using Function key if you select **ENHANCE:ON**. (See *Colour Enhancement* in this Chapter.)

- 9 Press **Colour Copy** to return to the screen:

Select the number of copies you wish to make and press

NO.OF COPIES:01

Colour Copy.



- The PhotoCapture Centre™ only prints in colour, no Black & White printing is available when using this feature.
- Enlargement or reduction is not available while using the PhotoCapture Centre™.
- User settings are kept until media card is inserted. The PhotoCapture Centre™ automatically goes back into its default setting after the media card is removed.

Changing Default Settings

By pressing **Menu, 5** and a number, you can adjust the Photo Capture Centre™ settings as shown in the following chart. Press the arrow (◀ or ▶) keys to move through the options for each setting. Press **Set** to save your selection.

Press **Menu, 5**.

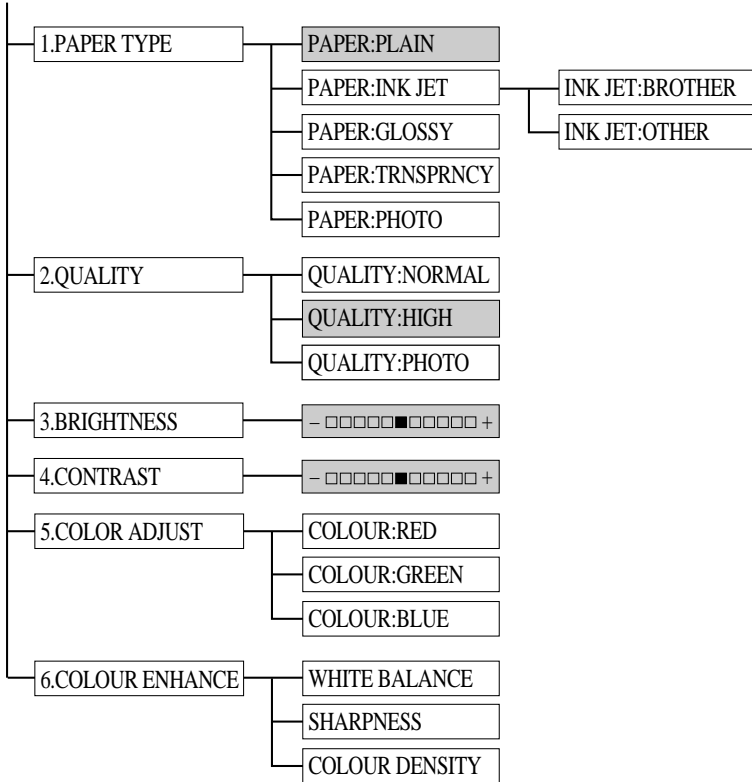

 : is default

Paper Type

- 1 Press **Menu, 5, 1**.

The screen displays:

- 2 Press ◀ or ▶ to select a paper type, and press **Set**.

- If you are using Brother coated paper, select **INK JET**, then select **BROTHER**.
- If you are using non-Brother ink jet paper, select **OTHER**.

- 3 When the screen displays the type of **INK JET** paper, press **Set**. If you did not select **INK JET**, go to Step 4.

- 4 Press **Stop** to exit.

1. PAPER TYPE

PAPER: PLAIN

PAPER: INK JET

PAPER: GLOSSY

PAPER: PHOTO

PAPER: TRNSPRNCY

Setting PhotoCapture Centre™ Quality

- 1 Press **Menu, 5, 2**. The screen displays **2. QUALITY**.

- 2 Press ◀ or ▶ to select a quality, and press **Set**.

- 3 Press **Stop** to exit.

2. QUALITY

QUALITY: NORMAL

QUALITY: HIGH

QUALITY: PHOTO

Photo Brightness

You can adjust the brightness setting before making a copy.

- 1 Press **Menu, 5, 3**.

- 2 Press ◀ to make a darker copy and press **Set**—OR—
Press ▶ to make a lighter copy and press **Set**.

- 3 Press **Stop** to exit.

Photo Contrast

You can choose the contrast setting for a copy. Greater contrast can help an image look sharper and more vivid.

- 1 Press **Menu, 5, 4**.

- 2 Press ◀ to decrease contrast and press **Set**—OR—Press ▶ to increase contrast and press **Set**.

- 3 Press **Stop** to exit.

Colour Adjustment

- 1 Press **Menu**, **5**, **5**.
- 2 Press ◀ or ▶ to select **RED**, **GREEN**, or **BLUE** and press **Set**.
- 3 Press ◀ or ▶ to adjust the degree of colour and press **Set**.
- 4 Return to Step 2 to select the next colour —**OR**— Press **Stop** to exit.



Colour Enhancement

- 1 Press **Menu**, **5**, **6**.
- 2 Press ◀ or ▶ to select **WHITE BALANCE** and press **Set**.
To skip White Balance, press ▶ to select **SHARPNESS** or **COLOUR DENSITY**.
- 3 Press ◀ or ▶ to adjust the degree of White Balance and press **Set**.
- 4 Repeat Step 2 and Step 3 to adjust the degree of Sharpness and Colour Density —**OR**— Press **Stop** to exit

■ White Balance

This setting adjusts the hue of the white sections of an image. Lighting, camera settings and other influences will effect the appearance of white. The white parts of a picture may appear to be slightly pink, yellow or some other colour. By using this adjustment you can correct this effect and bring the white sections back to pure white.

■ Sharpness

This setting enhances the detail of an image. This is similar to adjusting the fine focus on a camera. If the focus is off a small amount you can not clearly, see the fine details of an image.

■ Colour Density

This setting adjusts the total amount of colour in the image. You can increase or decrease the amount of colour in an image to improve a picture which may appears washed out or weak.

Understanding Error Messages

Once you are familiar with the types of errors that might occur while you're using the PhotoCapture Centre™, you can easily identify and troubleshoot difficulties. When an error message appears on the LCD, the MFC will beep to get your attention.

MEDIA ERROR—This message appears when you insert a media card that is either bad or not formatted, or if there is a problem with the media drive. To clear this error, remove the media card.

NO FILE—After you press the Colour Copy key, this message will appear if the media card in the media drive does not contain a .JPG file, or if the DPOF print file on the media card selects a .JPG image that is not on the card.

MEMORY FULL—This message appears when you are working with images that are too large for the MFC's memory.

PhotoCapture Centre™ Requirements

To avoid error conditions, please remember:

- The DPOF file on the media card must be in a valid format.
- The image file extension must be .JPG (JPEG, TIF and other image file extensions will not be recognized).
- Walk-Up PhotoCapture Centre™ printing must be performed separately from PhotoCapture Centre™ operations using the PC. (Simultaneous operation is not available.)



When printing the INDEX or IMAGE, the PhotoCapture Centre™ will print all the valid images, even if one or more images has been corrupted. Depending on where the bad data occurs, a portion of a corrupted image may be printed.

13 Setting Up the MFC and PC to Work Together

Using the Brother Machine with Your PC

Multi-Function Link[®] Pro software (MFL Pro) turns your Brother machine into a multi-function centre, by enabling you to use your fax machine as a printer and a scanner and to use it from Windows[®] applications in your computer.

The MFC-830 is a 5 in1 multi-function centre and the MFC-840 is a 6in1 multi-function centre. Install the Multi-Function Link[®] Pro and other Brother software from the enclosed CD-ROM.



If you have previously installed Brother Multi-Function Link[®] Pro software for another machine, uninstall it first.

Before You Install Multi-Function Link[®] Pro



If you have a USB cable (For Windows[®] 98, 98SE and Windows[®] 2000 Professional users only), see *Using a USB Cable to Connect the MFC to the PC (Using Windows[®] 98, 98SE and Windows[®] 2000 Professional Only)* in this Chapter.



If you have a bi-directional IEEE-1284 compliant parallel cable, see *Using a bi-directional IEEE-1284 compliant parallel cable to Connect the MFC to the PC (Using Windows[®] 95, 98, 98SE, Windows NT[®] Workstation Version 4.0 and Windows[®] 2000 Professional)* in this Chapter.



It is important that you connect your MFC to your computer **before** you install the software.

Computer Requirements

The following are the minimum computer requirements you need to set up and operate the MFC drivers.

COMPUTER REQUIREMENTS				
Windows® Operating System	Speed (or Higher)	RAM	HD Space	CD-ROM Speed
95, 98, 98SE	Pentium 75MHz	24MB (32MB rec.)	50MB	2X
NT 4.0 Workstation	Pentium 75MHz	32MB (64MB rec.)	50MB	2X
2000 Professional	Pentium 133MHz	64MB (128MB rec.)	50MB	2X



Use only a shielded parallel interface cable that is IEEE-1284 compliant and/or a USB cable that is no longer than 6 feet long (1.8 meters).

Using a bi-directional IEEE-1284 compliant parallel cable to Connect the MFC to the PC (Using Windows® 95, 98, 98SE, Windows NT® Workstation Version 4.0 and Windows® 2000 Professional)

IMPORTANT

To install the software using Windows NT® Workstation Version 4.0 or Windows® 2000 Professional, you must be logged on as the Administrator.

- 1 ▶ Unplug the MFC power cord from the electrical outlet before connecting the parallel interface cable.
- 2 ▶ Make sure the computer is turned off and unplugged from the electrical power before you connect the interface cable.
- 3 ▶ Connect the parallel interface cable to the parallel interface port of the MFC and secure the wire clips.



When you connect the MFC to your computer you must use the included Brother bi-directional IEEE-1284 compliant parallel cable.

- 4** Connect the interface cable to the printer port of the computer and secure it with the two screws.

For the location of your computer's parallel printer port, see the User's Guide for your computer.

- 5** Before plugging in your computer and turning it on, plug in the AC cord of the Brother machine, then turn on your PC.

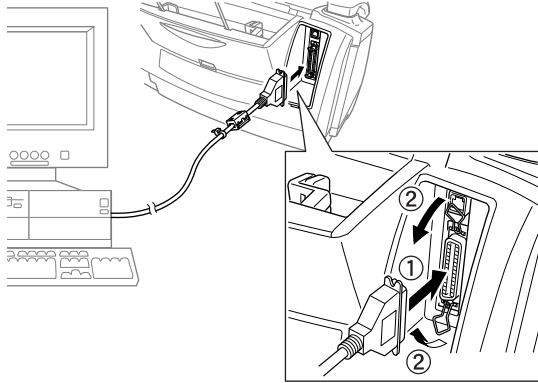

Please follow the instructions for the operating system you are using.

Using Windows® 95, 98 and 98SE



Now begin the installation of the Brother Drivers:

- If you are using Windows® 2000 Professional, go to “*Using Windows® 2000 Professional*” on page 82.
- If you are using Windows NT® Workstation Version 4.0, go to “*Using Windows NT® Workstation Version 4.0*” on page 86.

For Windows® 95 OSR2, 98, 98SE user:

- 6** When the Add New Hardware Wizard screen appears, click **Next**.



Each operating system has different dialog box. Some text may be different depending on which operating system you are using.

For Windows® 95 user:



The instructions in Steps 7 to 16 are samples for Windows® 98SE.

- 7 Select **(Recommended)** and click **Next**.



- 8 Insert the **MFL Pro CD-ROM** into your CD-ROM drive.

- 9 Select **Specify a location** and remove the other check marks, then click **Browse** to locate the file.



10 Double-click the CD icon and click the “x:\eng\w9x\para” folder. (X:is the drive letter for your CD-ROM drive), then click **OK**.

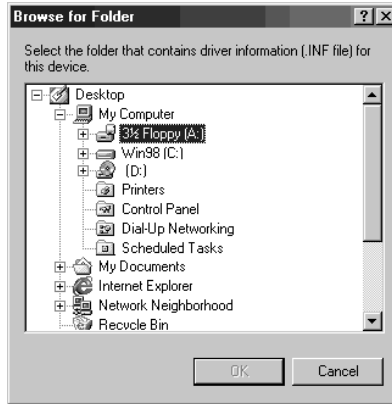

11 Make sure **Specify a location** is selected and click **Next**.



12 Make sure your printer driver name is displayed and click **Next**.



- 13** You can type a name for this printer, or you can use the name supplied on screen. When you have finished, click **Finish**.



- 14** When the Add New Hardware Wizard displays click **Finish**.



- 15** When the Setup Window appears, and the status bar reaches 100%, the remaining drivers will be copied.

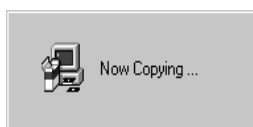
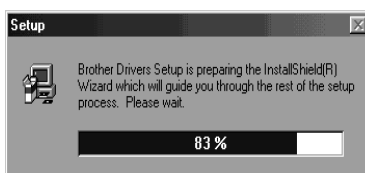

- 16** Click **OK**.



- 17** All the drivers have been installed. Now you can print and scan.



If you want to install PaperPort® or Multi-Function Link® Pro, go to the CD section.
(See *Installing the Brother Software* in this Chapter.)

Using Windows® 2000 Professional

- 6 When the Found New Hardware Wizard screen appears, click **Next**.



- 7 Select **(Recommended)** and click **Next**.



- 8 Insert the **MFL Pro CD-ROM** into your CD-ROM drive.

- 9 Select **Specify a location** and remove the other check marks, then click **Next**.

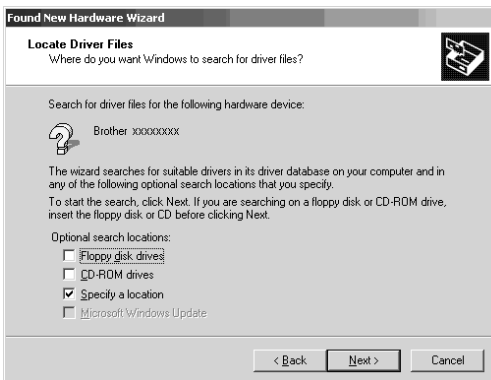

- 10 Click **Browse** to locate the file.



- 11 Double-click on the CD icon and click on the "x:\eng\w2k\para" (x is the drive letter for your CD-ROM drive.) folder, then click **OK**.

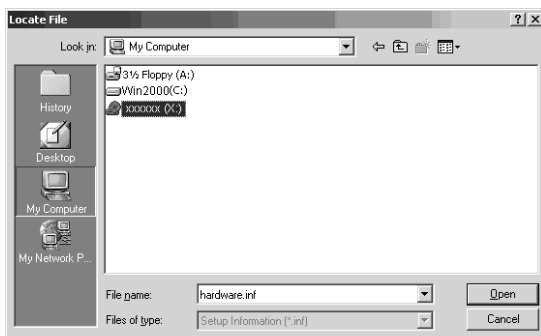

12 Make sure **Specify a location** is selected and click **Next**.

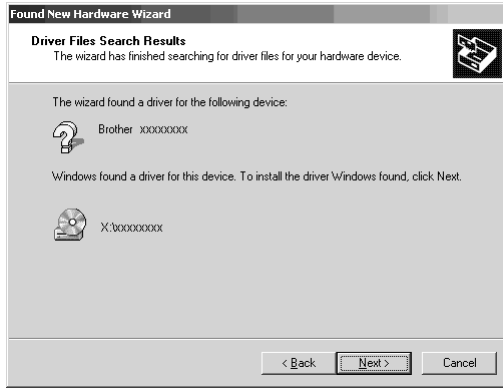

13 Click **Finish**.



14 Repeat Steps 6 - 13 to install the Printer and Scanner drivers.





You might see “Digital Signature Not Found” dialog during installation. If you see it, click **Yes** to install the driver.



15 Click **Finish**.



16 When the Setup window appears, and the status bar reaches 100%, the remaining drivers will be copied.

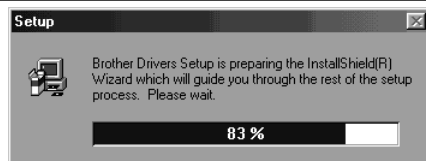

17 Click **OK**.



18 All the drivers have been installed. Now you can print and scan.



If you want to install PaperPort® or Multi-Function Link® Pro, go to the CD section. (See *Installing the Brother Software* in this Chapter.)

Using Windows NT® Workstation Version 4.0

- 6 Windows NT® Workstation 4.0 does not have Plug & Play, so you have to install the drivers manually. Click the **Start** button in the Task bar, and select **Setting**, then **Printer**. Then double click **Add Printer**.

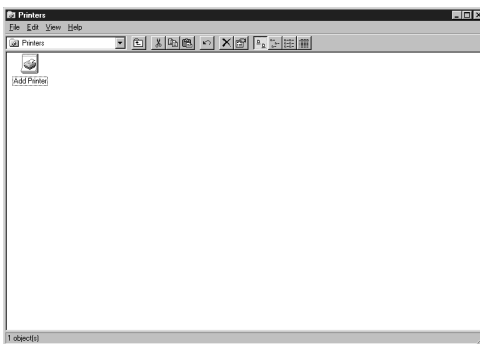

- 7 Select **My Computer** and click **Next**.



- 8 Select **LPT1:** and click **Next**.

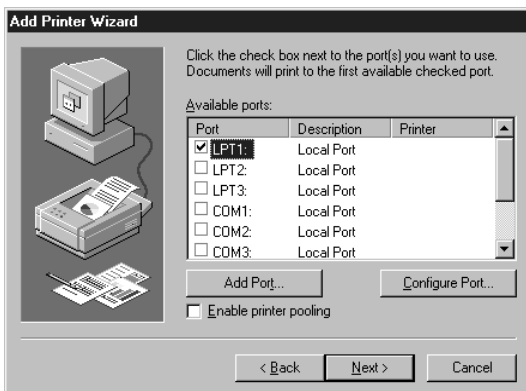

- 9 Insert the **MFL Pro CD-ROM** into your CD-ROM drive. Click **Have Disk...**

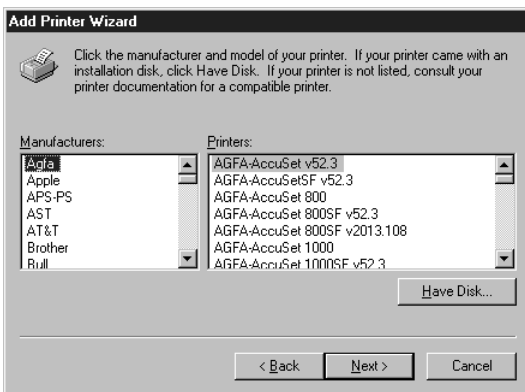

- 10 Click **Browse** to locate the file.

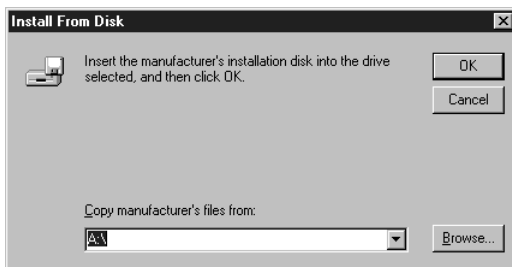

- 11 Double-click on the CD icon and click on the "**x:\eng\nt40**" (x: is the drive letter for your CD-ROM drive.) folder, then click **Open**.

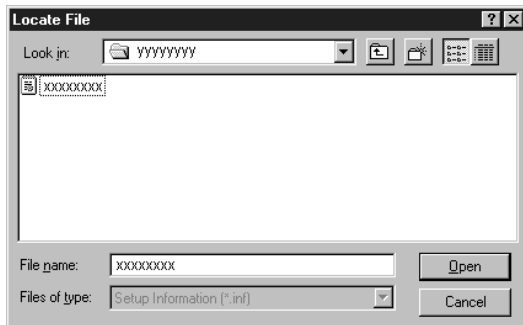

- 12 Make sure **Specify a location** is selected and click **OK**.



13 Select your printer model, then click **Next**. This dialog box may not be displayed on some MFC models.

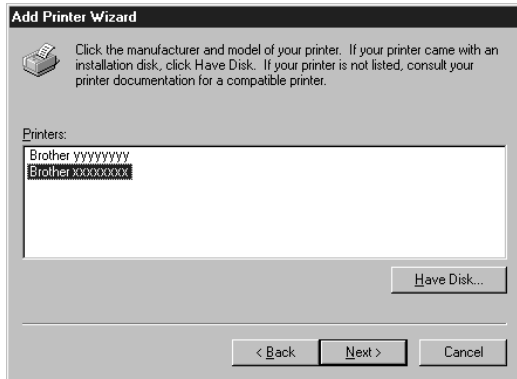

14 Click **Next**.



15 Select **Not Shared**, then click **Next**.

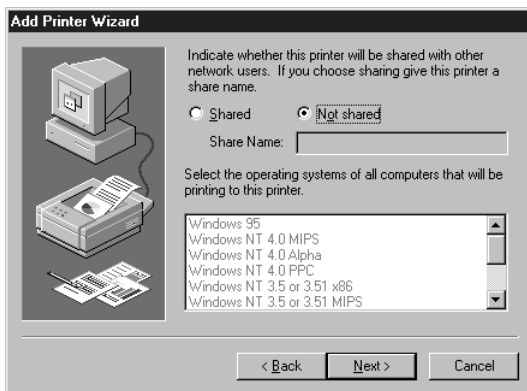

- 16** Select **Yes (Recommended)** to Print a Test Page and click **Finish**.



- 17** After the test page has been printed, click **Yes**.

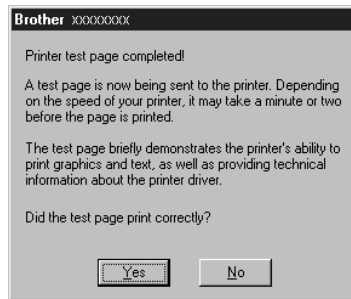

- 18** Now the printer driver has been installed, and you can see the driver in the Printer list.

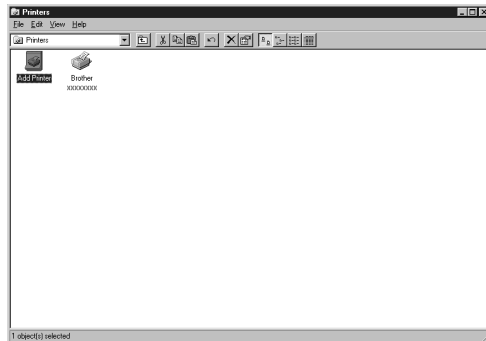

- 19** The rest of the Brother drivers, will have to be installed manually. Click the **Start** button in the task bar, then select **Run**. Enter **x:\eng\nt40\setup\setup.exe** and click **OK**.



- 20** When the Setup Window appears, and the status bar reaches 100%, the remaining drivers will be copied.

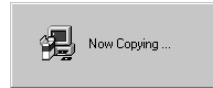
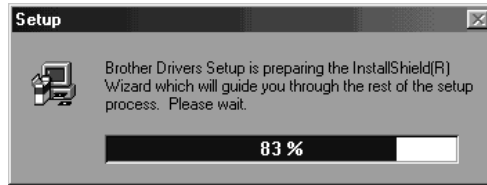

- 21** Click OK.



- 22** All the drivers have been installed. Now you can print and scan.



If you want to install PaperPort® or Multi-Function Link® Pro, go to the CD section. (See *Installing the Brother Software* in this Chapter.)

Using a USB Cable to Connect the MFC to the PC (Using Windows® 98, 98SE and Windows® 2000 Professional Only)

IMPORTANT

To install the software using Windows® 2000 Professional, you must be logged on as the Administrator.



Before you can connect the MFC to your computer, you must purchase a USB cable that is no longer than 6 feet (1.8 meters).

Notice to Computer Users

A small filter core and cable tie are enclosed in a vinyl bag with your MFC. **PLEASE SAVE THESE PARTS.** You will need them in the future if you connect the MFC to a Computer. For optimal performance, use a USB Cable with the enclosed Filter core and Cable tie.

When you use a Computer with your MFC, please attach the enclosed Filter core to a USB Cable.

- 1 Attach the cable tie 50mm or less from the end of the USB Cable that will be connected to the MFC.

- 2 Attach the filter core between the USB Cable Connector and the Cable Tie by pressing until you hear a click.

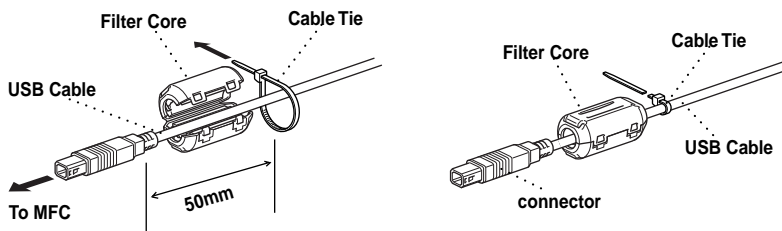

- 3 After you have set up the MFC and checked that it is working properly, make your PC is turned off.
- 4 Connect the USB cable to both the MFC and the PC.

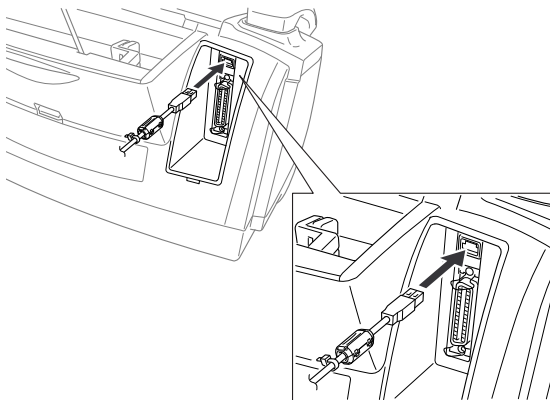

- 5 Turn on your PC.

Using Windows® 98, 98SE



Now begin the installation of the Brother Drivers:
If you are using Windows® 2000 Professional, go to "*Using Windows® 2000 Professional*" on page 97.

- 6 For Windows® 98, 98SE users:

When the Add New Hardware Wizard screen appears, click **Next**.



Each operating system has different dialog. Each driver may be installed in different order depending on which operating system you are using.



- 7 Select **(Recommended)** and click **Next**.



- 8 Insert the **MFL Pro CD-ROM** into your CD-ROM drive.

- 9 Select **Specify a location** and remove the other check marks, then click **Browse** to locate the file.



- 10 Double-click the CD icon and click the “**x:\eng\W98\usb**” folder for Windows® 98, 98SE user, then click **OK**.



11 Make sure **Specify a location** is selected and click **Next**.



Make sure the location is "x:\englw98\usb" for Windows® 98/98SE.



12 Click **Next**.



If the Insert Disk Wizard appears, remove the **MFL Pro CD-ROM** and insert the **Windows® 98/98SE CD-ROM** (to get the Windows® standard driver) and click **OK**.

13 Click **Finish**.

(If you inserted the **Windows® 98/98SE CD-ROM**, remove the **CD-ROM** and reinsert the **MFL Pro CD-ROM**)



- 14** After the **Composite USB Device** is installed and the Add New Hardware Wizard reappears, click **Next**.



- 15** Select **(Recommended)** and click **Next**.



- 16** Select **Specify a location** and click **Next**.



17 Click **Next**.



18 When the Add New Hardware Wizard displays the message that installation is completed, click **Finish**.



To install all the drivers, repeat Steps 6 to 12.

19 After the USB Composite Device, PhotoCapture Centre™ (For MFC-840 only) Fax Modem, Scanner and Printer Drivers have been installed, select **BRUSB: USB Printer Port** as the printer port and click **Next**.

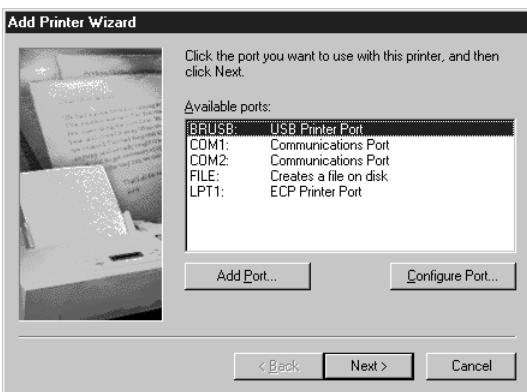

- 20** Enter a name for the printer, or you can use the name supplied. When you have finished, click **Next**.



- 21** Select **Yes (Recommended)** to print a Test Page and click **Finish**.

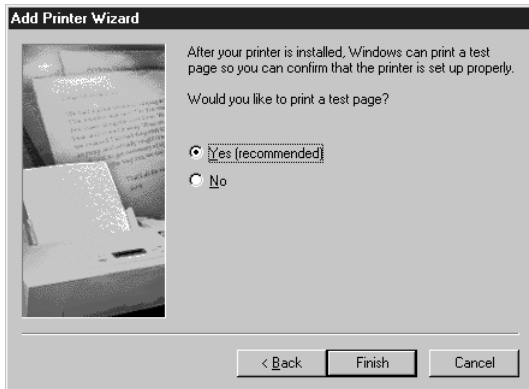

- 22** After the test page has been printed, click **Yes**.

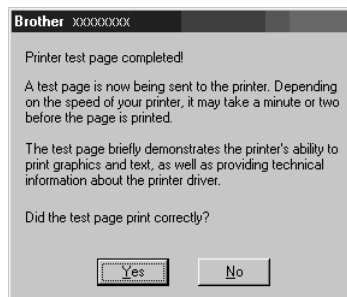

- 23** When the Add New Hardware Wizard displays the message that the software has been installed, click **Finish**.



- 24** All the drivers have been installed. Now you can print and scan.



If you want to install PaperPort® or Multi-Function Link® Pro, go to the CD section. (See *Using Windows® 2000 Professional* in this Chapter.)

Using Windows® 2000 Professional

- 6** When the Found New Hardware Wizard screen appears, then click **Next**.



- 7** Select **(Recommended)** and click **Next**.



8 Insert the **MFL Pro CD-ROM** into your CD-ROM drive.

9 Select **Specify a location** and remove the other check marks, then click **Next**.

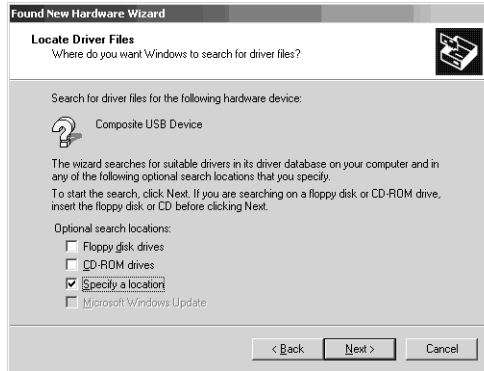

10 Click **Browse** to locate the file.



11 Double-click on the CD icon and click on the **"x:\eng\w2k\usb"** (x: is the driver letter for your CD-ROM drive) folder, then click **OK**.

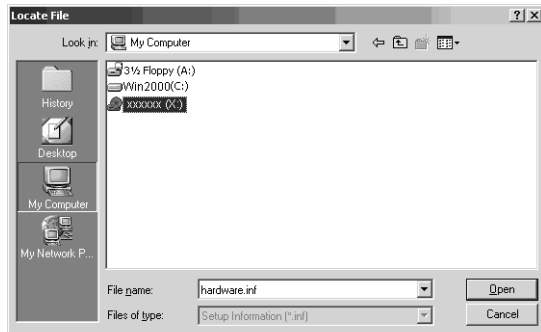

12 Make sure **Specify a location** is displayed.



13 Click Next.



14 Click Finish.



15 To install the other drivers, repeat Steps 6 to 14.



You might see "Digital Signature Not Found" dialog during installation. If you see it, click **Yes** to install the driver.



16 All the drivers have been installed. Now you can print and scan.



If you want to install PaperPort[®], or Multi-Function Link[®] Pro, go to the CD section. (See *Installing the Brother Software* in this Chapter.)

Installing the Brother Software

IMPORTANT

You must install drivers for Printer and Scanner before you install the software (MFL Pro). See *the beginning of this chapter.*

- 1 Insert MFL Pro CD-ROM into your CD-ROM drive.

The Language Selection Screen appears. Click on your language menu.

(If this window does not appear, please use Windows Explorer to run the setup.exe program from the root directory of the Brother CD.)

The main CD-ROM screen appears:



If you are using Windows® 2000 Professional or NT®4.0, you must be logged on as the Administrator, before you can install the software.

To install Multi-Function Link® Pro (Main Application):

- 1 Click on the first button “Install MFL-Pro”.
- 2 Follow the instructions on the screen. ScanSoft™ PaperPort® will be installed first, then MFL-Pro will be installed. After the installation, you must restart your PC.



Clicking **Install MFL-Pro**, will install the Multi-Function Link® Pro, ScanSoft™ PaperPort®, and ScanSoft™ TextBridge® OCR applications.



Multi-Function Link® Pro includes, Remote Setup and True Type fonts. PaperPort® is a document management application for viewing incoming faxes and scanned documents. ScanSoft™ TextBridge® is an OCR application that converts an image into text and integrates it into PaperPort®.

To view On-Line Documentation:

- 1 When you click “*View On-Line Documentation*” from the main menu, the following screen appears:



- 2 To view documentation, click on the appropriate button.
If you do not have Adobe Acrobat Reader on your system at this time, you can install it now by clicking **Install Adobe Acrobat Reader**. The latest English language Adobe Acrobat Reader has been included on the enclosed CD, For further information, and other language, contact : <http://www.adobe.com>. This software is free to download.
- 3 When you are finished viewing On-Line Documentation, click **Back** to return the main CD-ROM screen.

To View Brother Home Page:

From the main screen you can access the Brother Home Page, by clicking **Brother Home Page**.

To access our web site at www.brother.com, where you will find additional information about Brother products and services, such as specification sheets and Frequently Asked Questions (FAQs), click **Brother Home Page**.

Helpful Hints for Windows® 95/98/98SE/ 2000 Professional or Windows NT® 4.0

The installer automatically sets the printer port to the parallel interface, BRMFC (for Windows® 95/98/98SE) and BMFC (for Windows NT® Workstation 4.0 and Windows® 2000 Professional).



To uninstall Multi-Function Link® Pro, click the Uninstall icon in the Brother MFL Pro Program group and follow the instructions on the screen.

14 Using the MFC as a Printer

Features

The Multi-Function Centre offers you many features you will find in a high quality ink jet printer.

Fast Printing Speed—Using Draft mode, you can print up to 10 pages per minute in full colour.

Brilliant 4-Colour Output at 300 dpi—Printing at 300 dpi resolution gives you normal resolution output.

Brilliant 4-Colour Output at 600 dpi—Printing at 600 dpi resolution on special coated paper or glossy paper gives you high resolution output.

Brilliant 4-Colour Output at 1200 dpi—Printing at 1200 dpi resolution on special coated paper or glossy paper gives you highest resolution output.

Low Running Cost—Whenever you run out of a particular colour ink, you will replace only the cartridge that's empty.

Bi-directional Parallel Interface—The parallel interface allows bi-directional (IEEE 1284 compliant) communication with your computer.

USB—Universal Serial Bus Interface allows for fast communication with your computer.

Straight Paper Path—The MFC can use various types of paper: plain paper, Ink Jet Paper (Coated Paper), glossy paper, transparencies, and envelopes. Using the appropriate paper reduces the occurrence of paper jams. For complete information about what kinds of paper to use with the MFC, please read "*Brother Paper*", in chapter 23.

Printer Driver

You can change the following printer settings when you print from your computer:

- Quality (Speed) /Media
- Colour Matching
- Halftone/Colour Enhance

Choosing the Right Kind of Paper

To achieve high quality printing using your MFC, it's very important to select the right kind of paper. Be sure to read "Brother Paper", Chapter 23 in this manual, before selecting and purchasing paper for the MFC.

Multi-purpose Sheet Feeder

The multi-purpose sheet feeder can feed plain paper, coated paper, glossy paper, transparencies, envelopes, and organizer paper (K, L). When the MFC receives data from your computer, it begins the print process by loading paper from the multi-purpose sheet feeder.

- 1 Select the print command from your PC.
- 2 Your PC sends a print command and data to the MFC. The screen displays RECEIVING DATA.
- 3 If there are more pages, the MFC begins to print the next page automatically.
- 4 When the MFC finishes printing all data, it returns to display the date and time.



You can select paper source, paper size, and orientation in your application software. If your application software does not support your custom paper size, select the next larger paper size. Then adjust the print area by changing the right and left margins in your application software.

Loading Paper

You can use plain paper, coated paper, transparencies, glossy paper, envelopes and organizer (K, L) in the multi-purpose sheet feeder. (See Chapter 3 for more information about paper types.)

- 1 Open the control panel cover by pulling it toward you, then lift the top cover toward the back. When you want to print on regular paper, keep the purple paper thickness adjustment lever up. When you want to use thick paper, press the lever down. Then, close the top cover and the control panel cover.
- 2 Remove any paper in the Feeder, and load the new paper. Fan the stack of paper before loading.
- 3 Load the paper stack with the printing (coated) side facing up. Adjust the paper guide. Make sure the paper is stacked below the arrow. You can load up to approximately 100 sheets of 20 lb (75g/m²) plain paper.

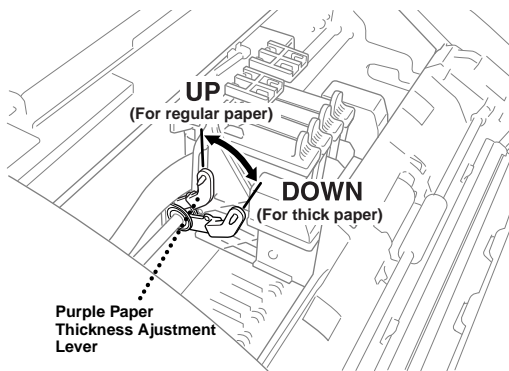

If you see ink smudges on the top centre of the printed pages, press the purple thickness adjustment lever down.

Simultaneous Printing/Fax

Your MFC can print data from your computer while sending or receiving a fax, or while scanning information into the computer. However, when the MFC is copying or receiving a fax on paper, it pauses the PC printing operation, and resumes when copying or fax receiving is complete. Fax sending will continue during PC printing.

Printer Operation Keys



Reset Key

If the screen displays **REMAINED DATA**, you can clear data remaining in the printer memory by pressing **Reset**.

Ink Management Key

When you press **Ink Management**, the LCD displays:

If you are having trouble with one of the ink colours, you may need to clean the print head. (See *Troubleshooting and Maintenance* in Chapter 21.)

1. CLEANING

2. REPLACE INK

If you got an error message **NEAR EMPTY XXXX** or **INK EMPTY XXXX**, you will need to replace the ink cartridge for the appropriate colour. (See *Troubleshooting and Maintenance* in Chapter 21.)

Turning Off Bi-directional Printing

You can further improve print quality by turning off bi-directional printing and setting the MFC to print in one direction only. However, this will reduce print speed by one half.

1 Press **Menu**, **2**, **3**.

3. BI-DIR PRINT

2 Press ◀ or ▶ to select **OFF**.

15 Printer Driver Settings

Using the Brother MFC-830/MFC-840 Printer Driver

The Brother MFC-830/MFC-840 printer driver enables you to change settings and override defaults as you change your paper, document type, and colours for printing. In the Brother MFC-830/MFC-840 on BRMFC: Properties dialog box there are two tabs: Paper and Quality/Colour, so you can change print properties as needed.

The Paper Tab

The paper tab screen allows you to set up the Paper Size, Paper Source, Orientation, Scaling, and Copies.

To access the Brother printer driver, select **Print** from the File menu. In the Print dialog box, select Brother MFC 830/Brother MFC 840 from the Name drop down list. Click the Properties button. The Brother MFC 830/MFC 840 on BRMFC: Properties dialog box will appear:

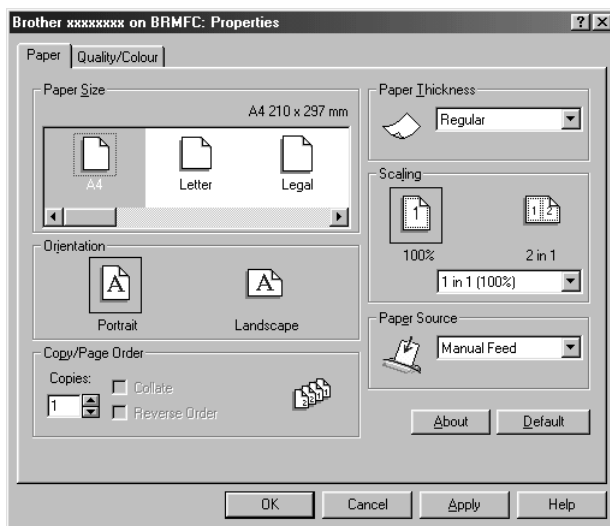

Select the **Apply** button to apply your selected settings.

To return to the default settings, click the **Default** button, then click the **Apply** button.

Paper Size

You can select from the following sizes of paper and envelopes:

Letter (US)	215.9 x 279.4 mm (8 1/2 x 11 inches)
Legal (US)	215.9 x 355.6 mm (8 1/2 x 14 inches)
Executive (US)	184.2 x 266.7 mm (7 1/4 x 10 1/2 inches)
A4	210 x 297mm
A5 (International)	148 x 210 mm (5.8 x 8.3 inches)
Post Card (US)	127 x 177.8 mm (5 x 7 inches)
Photo Card (US)	101.6 x 152.4 mm (4 x 6 inches)
Envelopes	
B5 (International envelope)	176 x 250 mm (6.9 x 9.8 inches)
C5 (International envelope)	162 x 229 mm (6.4 x 9 inches)
COM-10	104.8 x 241 mm (4 1/8 x 9 1/2 inches)
DL (International envelope)	110 x 220 mm (4.3 x 8.7 inches)
Monarch (US envelope)	98.4 x 190.5 mm (3 7/8 x 7 1/2 inches)
Organizer K	95.3 x 171.5 mm (3 3/4 x 6 3/4 inches)
Organizer L	139.7 x 215.9 mm (5 1/2 x 8 1/2 inches)

User Defined Paper Size

The printer can handle any paper size within the following range:

Minimum	90 x 127 mm	(3.5 x 5 inches)
Maximum	216 x 355.6 mm	(8.5 x 14 inches)

In this option, you can specify a custom paper size and save it by following this procedure:

- 1 Measure the paper size you want to use.
- 2 Select User Defined... in the paper size option.
- 3 Enter a unique name for your paper in the Custom Paper Size Name box.
- 4 Select either inch or mm for the unit of measure.
- 5 Type in the length and width.
- 6 Click the **Save** button to store the size. If necessary, you can delete a preset size by choosing the Delete button.



Your Windows application software may override this setting. Make sure you have set the proper paper size in your application software. In addition, check the margin settings when you select the smallest paper size. If they are too large, it may result in nothing being printed.

Orientation

Print orientation may be **Portrait** or **Landscape**. Portrait orientation means the page is taller than it is wide when you view the printed text upright. Landscape orientation means the page is wider than it is tall when you view the printed text upright.

Copies

The **Copies** selection tells Windows how many copies you want to print from a software application.



This setting is independent of the “copies selection” that may be available within the print menus of your software application.

Do not use the two selections simultaneously!

Collate

In multiple page jobs that are **uncollated**, several copies of Page 1 are printed followed by several copies of Page 2, followed by several copies of Page 3, etc. For example, for 2 copies of a 3 page document, the MFC prints Page 1, Page 1, Page 2, Page 2, Page 3, and Page 3 in order.

In multiple page jobs that are **collated**, a complete set of pages in a job are printed followed by another complete set of pages. For example, printing 2 copies of a 3 page document, the MFC prints Page 1, Page 2, Page 3, then Page 1, Page 2, and Page 3 in order. In this case, the MFC starts printing after processing all the print data so that it takes a longer time for collated printing than uncollated printing.

Reverse Order

The MFC normally prints Page 1 and ejects it face-up so that the following pages are stacked on top of previous pages. (Page 5, Page 4, Page 3 Page 1) When you want to get correct-ordered printouts, use this function. The MFC spools the job in your computer and sends the data starting from the last page to the printer. Since the MFC prints from the last page forward, the printouts are stacked Page 1, 2, 3, ...Page 5. Please note that this function takes more time.

Paper Thickness

To insure that the paper moves through the MFC without slipping (thin paper) or jamming (thick paper), be sure to select the appropriate paper thickness setting.

Regular — Select for ordinary plain paper.

Thin — Select when the paper is thinner than plain paper (for example organizer)

Thick — Select for thick paper. (for example 321b, Postcard)

Thicker — Select for thicker paper. (for example envelopes)

Scaling

Use this function to reduce or enlarge your document, from 50% to 200%.

2 in 1

Two pages are printed on one sheet at a reduced size. If you checked the “2 in 1 box”, you cannot specify the scaling percentage manually.



If your application software contains a similar function to this, both settings will be effective. **Do not use the two selections simultaneously!**

Paper Source

Feeder

The **multi-purpose sheet feeder** is primarily used for printing on standard-size paper and envelopes.

The Quality/Colour Tab

The Quality/Colour tab enables you to select the print quality, media, colours (matched to PC monitor, custom colours, or mono), and document type.

Click the Quality/Colour tab to display this screen:



Select the **Apply** button to apply your selected settings.

To return to the default settings, click the **Default** button, then click the **Apply** button.

Quality

Select the print quality. The print quality and speed are related. Higher quality takes a longer time to print.

- Draft:** 300 x 150 dpi. The fastest print mode (approximately two to four times faster than normal mode) and gives lower ink consumption. Use this mode to print large volume documents or a document for proofing.
- Normal:** 300 x 300 dpi. Recommended mode for ordinary printouts. Good print quality with comfortable printing speed.
- Fine:** 600 x 600 dpi. Better print quality than normal and faster print speed than Super Fine.
- Super Fine:** 1200 x 1200 dpi. Use this mode to print precise images such as photographs. Since the print data is much larger than normal mode, processing time, data transfer time, and printing time will be longer.

Media

Select the media (type of paper). The MFC changes the way it places dots depending on the selected media type. To get the best print output, make sure to select the correct media type.

Selecting media type changes the print quality selection to the most suitable one as listed below. We recommend that you print with the preset quality for best printing result.

Paper Type	Suitable print quality
Plain Paper	Normal
Ink Jet Paper (Coated Paper)	Fine
Glossy Paper	Super Fine
Photo Graphic Paper	Super Fine
Transparency	Normal
Transparency (mirror)	Normal



Use only genuine Brother Ink Jet Paper (Coated Paper), Glossy Paper, or Transparencies to get the best print quality. Non-Brother special paper may not produce the best quality.

Document

The printer driver will select the most suitable colour matching method depending on your document type. Generally, text and business graphics are printed vividly and photographic images are printed softly.

■ Auto

The printer driver automatically selects the document type. In most cases, we recommend using the Auto setting.

■ Photo

Select this mode for Photographic images.

■ Graphics

Select this mode for documents that contain text or business graphics (charts or clip art).

■ Custom

If you want to select the colour matching method and halftone method manually, select this mode and press the Colour Matching and the Custom Setting button to access further settings.

Colour/Mono

Colour

When your document contains colour and you want to print it in colour, select this mode. Only generic colours will appear on the printout (unless you also select colour matching).

Mono

Select this mode if your document has only black and grey scale text and/or objects. Mono mode makes the print processing speed faster than colour mode. If your document contains colour, selecting Mono mode prints it in 256 levels of grey scale.

Colour Matching

You can select the colour matching method manually. Select the best one for your document.

■ Match Monitor

Suitable for photographic images. Colour is adjusted to get the closest colour match to the PC monitor.

■ Vivid Colour

Suitable for business graphics such as charts, graphs, and text. The colour is adjusted to give more vivid colour.

Bi-Directional Printing

The MFC prints by moving its print head. Normally, it prints in both directions. By turning this option OFF (default setting is ON), the MFC prints (uni-directional) so that the print speed will be reduced to half.

Sometimes the moving speed of the print head may not be stable due to temperature changes, etc., and the printed vertical line may not be aligned exactly. If you encounter this problem, turn this option off or use the **Quality/Colour** menu and adjust the vertical line.

Custom Setting

You can customize your settings by selecting the type of Halftone or Colour Enhance.

Halftone Pattern

The MFC can use several methods to arrange where to place dots to express halftones. There are some predefined patterns used to place dots and you can select which one is used for your document. Select the appropriate method.

■ Photo

This method creates smooth halftones so that this is suitable for photographic images. It takes more time to process data, but this can express more levels of halftones and creates more natural images.

■ Cluster

This is suitable for business graphics such as charts, graphs and drawings, since this creates more sharp printouts. Moreover, the processing time is shorter.

Colour Enhance

■ COLOUR ENHANCE:ON

Adjusts the colour in the image for better print quality. Print time will be longer with Colour Enhance set to ON.

■ Sharpness

This setting enhances the detail of an image. This is similar to adjusting the fine focus on a camera. If the focus is off a small amount you can not clearly see the fine details of an image.

■ Colour Density

This adjusts the total amount of colour in the image. You can increase or decrease the amount of colour in an image to improve a picture which may appear washed out or weak.

■ White Balance

This adjusts the hue of the white sections of an image. Lighting, camera settings and other influences will effect the appearance of white. The white parts of a picture may appear to be slightly pink, yellow or some other colour. By using this adjustment you can correct this effect and bring the white sections back to pure white.

■ Brightness

Change the brightness of the whole image lighter or darker. Moving the scroll bar to the left makes your image darker and moving the scroll bar to the right makes your image lighter.

■ Contrast

Change the contrast of an image. Darker sections will be more dark and lighter sections will be more light as you increase the contrast. Increase the contrast when you want an image to be clearer. Decrease the contrast when you want an image to be more subdued.

■ Red

Increase the intensity of the Red colour to add red to the whole image.

■ Green

Increase the intensity of the Green colour to add green to the whole image.

■ Blue

Increase the intensity of the Blue colour to add blue to the whole image.

Brother Control Centre

The Brother Control Centre is a software utility that pops up on the PC screen whenever paper is placed in the ADF. This allows you to access the most frequently used scanning applications only with a few mouse clicks. Using the Control Centre eliminates the need to manually launch the specific applications.

The Brother Control Centre provides three categories of functions:

- 1 Scan directly to a file, E-mail, word processor or graphic application of choice
- 2 Enhanced copy functions, such as Two on One Copying

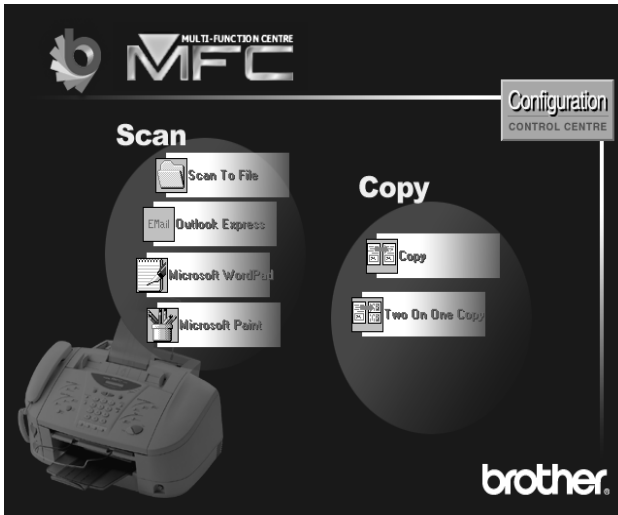



AutoLoad the Brother Control Centre

The Control Centre is initially configured to automatically load each time Windows® is started. When the Control Centre is loaded, the Control

Centre  icon will appear in the task bar. If you don't want the Control Centre to load automatically, you can turn off AutoLoad.

How to Turn Off AutoLoad

- 1 Left click the Control Centre  icon and click **Show**.
- 2 When the Control Centre icon appears, left click on the Configuration  Control Centre button. A dialogue box with a check box labeled “AutoLoad Pop-up” will appear:

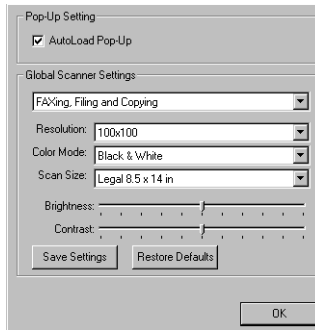

- 3 Uncheck the AutoLoad Pop-Up option.

Using the Scan Keys with PC Windows



If you have connected a Macintosh, the control panel keys will not work with your computer. Please see *Using the Brother MFC with a New Power Macintosh® G3, G4 or iMac™/iBook™* in Chapter 20.

You can use the Scan keys on the control panel to scan originals into your word processing, graphics or E-mail applications. The advantage of using the Scan keys is that you avoid the mouse clicks required to scan from your PC.

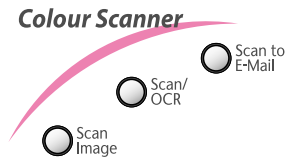

Using the Control Panel Keys

Before you can use the Scan keys on the control panel, you must have connected the MFC to your Windows® based PC and loaded the appropriate Brother Drivers for your version of Windows®. When you are ready to use the Scan keys, make sure the Brother Control Centre application is running on your PC. (For details about how to configure the Brother Control Centre buttons to launch the application of your choice using the Scan keys, see Brother Control Centre in Chapter 15.)

Scan Image

You can scan a colour picture into your graphics application for viewing and editing.

- 1 Place your original face down in the ADF.
- 2 Press **Scan Image**.
- 3 The MFC will scan the original and send a colour image to your graphics application.

Scan/OCR

If your original is text, you can have it automatically converted by ScanSoft™ TextBridge® to an editable text file and then displayed in your word processing application for further editing.

- 1 Place your original face down in the ADF.
- 2 Press **Scan/OCR**.
- 3 The MFC will scan the original perform OCR in ScanSoft™ TextBridge®, and then display the result in your word processing application for viewing and editing.

Scan to E-mail

You can scan either a black and white or a colour original into your E-mail application as a file attachment. Although the Brother Control Centre can be configured to send only black and white or colour file attachments at one time, you can easily change this setting. (For details see *Send Scan to E-mail* in this Chapter.)

- 1 Place the original face down in the ADF.
- 2 Press **Scan to E-mail**.
- 3 The MFC will scan the original, create a file attachment, and launch your E-mail application, displaying the new message waiting to be addressed.

Brother Control Centre Features

Auto Configuration

During the installation process the Control Centre checks your system to determine the default applications for E-mail, word processing and graphics viewer/editor. For example, if you are using Outlook as your default E-mail application, the Control Centre automatically will create a link and a scanning application button for Outlook.

You can change a default application by right clicking on any of the scan buttons in the Control Centre and selecting a different application. For example,

you can change a scan button from MS Word  to MS Word Pad  by changing the application that is listed for the Word Processor.



Scanning Operations

Scan to File—allows you to scan directly to a disk file with two mouse clicks. You can change the file type, destination directory and file name, as needed.

Scan to E-mail—enables you, with just two mouse clicks, to scan a picture or text document directly into an E-mail application as a standard attachment. You have the option of selecting the file type and resolution for the attachment.

Scan to Word Processor—enables you to scan a text document, run ScanSoft TextBridge OCR and insert the text original (not graphic image) into a word processing file with just two mouse clicks. You have the option of selecting the destination word processing program, such as Word Pad, MS Word, Word Perfect, etc.

Scan to Graphic Application—allows you to scan an image directly into any graphic viewer/editor application. You can select the destination application, such as MS Paint or Corel PhotoPaint.

Copy Operations

Copy—allows you to use the PC and any Windows® printer driver for enhanced copy functions. You can scan the page on the Brother MFC and print the copies using any of the features of the Brother MFC printer driver—**OR**—you can direct the copy output to any standard Windows® printer driver installed on the PC.

Two on One Copy—allows you to use the Two on One page feature of the Brother printer driver to copy two original pages onto a single output page. This feature creates a thumbnail of each page and prints both images on a single page.

Scanner Settings for Scan and Copy Buttons

When the Pop-Up screen is displayed, you can access the Scanner Settings window.

Click the Configuration  icon at the top right of the Brother Control Centre screen—**OR**—Click the **Modify Settings...** button on any of the Configuration screens.

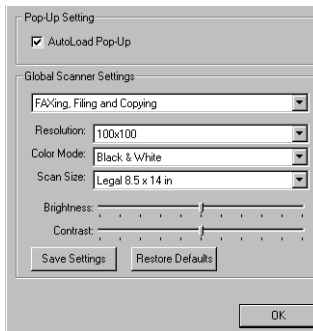

Global Settings

AutoLoad Pop-Up—Click this checkbox if you want Brother MFL Control Centre to load when you boot your computer.

Setting Up the Scanner Configurations

The Pop-Up application stores eight different scanning modes. Each time you scan an original, you will choose the most appropriate scanning mode from the following:

- Filing and Copying
- Text for OCR
- Photos
- Photos (High Quality)
- Photos (Quick Scan)
- Custom
- Draft Copy
- Fine Copy

Each mode has its own set of stored settings. You can keep the factory default settings or change them at any time:

- Resolution*—Select the scanning resolution you most frequently use.
- Colour Mode*—From the pull-down list.
- Scan Size*—From the pull-down list.
- Brightness*—Slide the adjuster from 0% to 100%
- Contrast*—Slide the adjuster from 0% to 100%

Click **OK** to save your changes. If you make a mistake or later decide to return to the original default setting, just click the **Restore Defaults** button when the scanning mode is displayed.

To access the Scanner Configurations screen:

- 1 Place the original in the ADF.
- 2 Right-click the appropriate Control Centre button to display *Configurations...*, then click it. The configuration screen for that **Control Centre** button will appear.
- 3 To save your settings, press the **OK** button—**OR**—To return to the factory default settings, press the **Restore Defaults** button.

Perform an Operation from the Control Centre Screen

If you see this screen it means you left-clicked a button in the Control Centre window without first placing an original in the ADF.

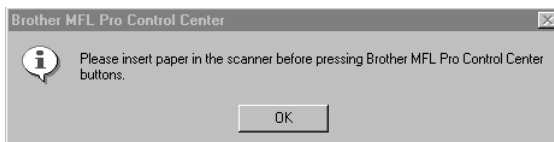

Place the original in the Brother machine's ADF, then click **OK** to return to the Control Centre screen.

Scan to File

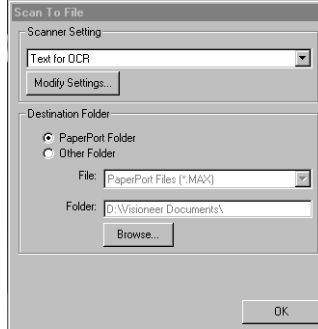

Scanner Settings

From the pull-down list, select the scanning mode that is appropriate for the type of file: Filing and Copying; Text for OCR; Photos; Photos (High Quality); Photos (Quick Scan); Custom; Draft Copy or Fine Copy.

To change any of the settings for that mode, click the **Modify Settings...** button.

Destination Folder

PaperPort Folder—Select this checkbox to scan the original into your PaperPort folder.

Other Folder—Select this checkbox, to scan the original as another file type and/or into another directory/folder.

File—If you selected Other Folder, from the pull-down list select the type of file:

- PaperPort Files (*.MAX)
- Self Viewing Files (*.EXE)
- PaperPort 5.0 Files (*.MAX)
- PaperPort 4.0 Files (*.MAX)
- PaperPort 3.0 Files (*.MAX)
- Windows Bitmap (*.BMP)
- PC Paintbrush (*.PCX)
- Multi-page PCX (*.DCX)
- JPEG Image Files (*.JPG)
- TIFF-Uncompressed (*.TIF)
- TIFF Group 4 (*.TIF)
- TIFF Class F (*.TIF)
- Multi-Page TIFF-Uncompressed (*.TIF)
- Multi-Page TIFF Group 4 (*.TIF)
- Multi-Page TIFF Class F (*.TIF)
- PDF Files (*.PDF)
- Portable Network Graphics (*.PNG)
- FlashPix (*.FPX)
- HFX Fax Files (*.HFX)

To Search your system for the directory and folder you want, click the **Browse...** button. Click **OK** to save your settings.

Send Scan to E-mail

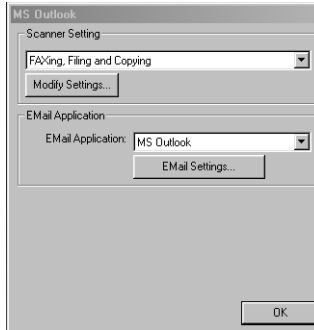

Scanner Settings

From the pull-down list, select the scanning mode that is appropriate for the type of file: Filing and Copying; Text for OCR; Photos; Photos (High Quality); Photos (Quick Scan); Custom; Draft Copy or Fine Copy.

To change any of the settings for that mode, click the **Modify Settings...** button.

Email Application

Email Package—From the pull-down list, select your E-mail application.

Email Settings—Click the **EMail Settings...** button to set up links.

The Links Preferences window will appear:

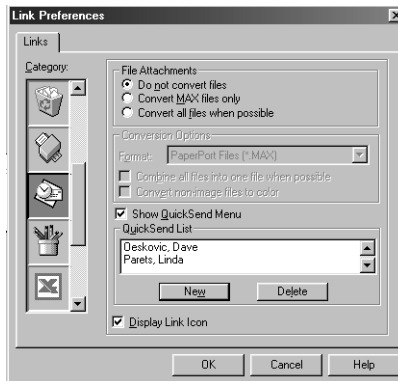

File Attachments

Do not convert files—Click this checkbox if you do not want to change the file type of attachments. The Conversion Options will not be available (grayed).

Convert MAX files only—Click this checkbox if you want to convert only attachments that are PaperPort files.

Convert all files when possible—Click this checkbox if you want to change the file type of all attachments.

Conversion Options

Format

Combine all files into one file when possible—Click this checkbox to combine all files of the same type into one file.

(For Brother Colour Models Only) *Convert non-image files to colour*—Click this checkbox to convert all files that have been processed through OCR to colour.

Show QuickSend Menu

Click this checkbox if you want the Select QuickSend Recipient window to be displayed when you choose Scan to E-mail. This feature works only with MAPI type E-mail applications, such as Microsoft Exchange, Microsoft Outlook and Eudora.

QuickSend List

You can create a list of Email names and addresses for quick selection.

Click the **New** button to add a name(s) to your QuickSend list. Your Email phone book listing is displayed, so you can select stored names or create new ones:

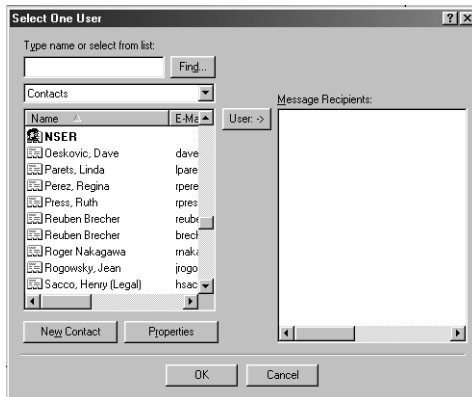

Highlight the name(s) you want to add to your list, click the **User** button, then click **OK** to return to the Link Preference window.

From the Link Preference window, you can remove a name from the QuickSend list, by highlighting the name and clicking the **Delete** button.

Send Scan to Word Processor

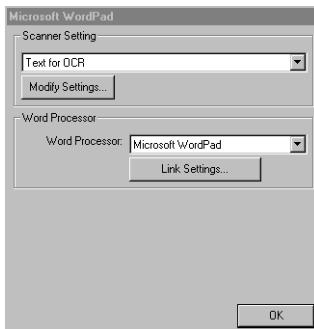

Scanner Settings

From the pull-down list, select the scanning mode that is appropriate for the type of file: Filing and Copying; Text for OCR; Photos; Photos (High Quality); Photos (Quick Scan); Custom; Draft Copy or Fine Copy.

To change any of the settings for that mode, click the **Modify Settings...** button.

Word Processor

Word Processor—From the pull-down list, select the word processor you want to use.

Click the **Link Settings...** button to display a screen to set up a link to the version of OCR and document format that you want to use:

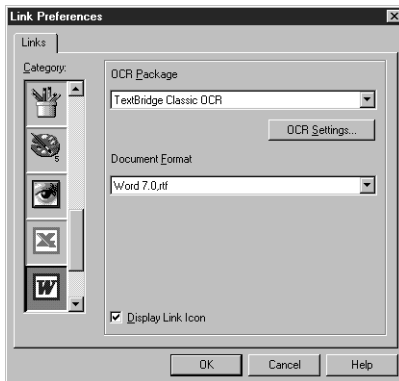

OCR Package—From the pull-down list, select *TextBridge Classic OCR* if you want to use the OCR package that was installed with the Brother software.

Click the **OCR Settings...** button to choose how the OCR application will read the pages you scan into your word processor application.

The Preferences window will appear:

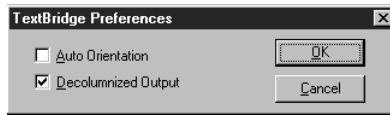

Select your setting and click **OK**.

- ◆ *Auto Orientation*—Check this checkbox if you want your word processor application to read the page as it is set up.
- ◆ *Decolumnized Output*—Check this checkbox if you want your word processor application to read across the entire page from left to right.
- ◆ *Document Format*—From the pull-down list, select the file format you want to use for your word processor or text documents.

User Defined Button

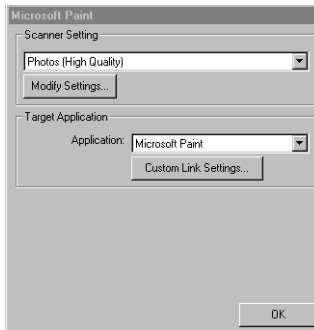

Scanner Settings

From the pull-down list, select the scanning mode that is appropriate for the type of file: Filing and Copying; Text for OCR; Photos; Photos (High Quality); Photos (Quick Scan); Custom; Draft Copy or Fine Copy.

To change any of the settings for that mode, click the **Modify Settings...** button.

Target Application

Application—From the pull-down list, select the application you want to add to this Pop-Up screen. Click the **Custom Link Settings...** button to set up links for your user-defined application.

Copy/Two on One Copy

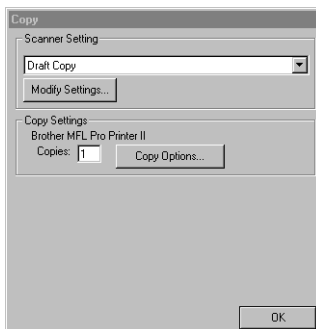

Scanner Settings

From the pull-down list, select the scanning mode that is appropriate for the type of file: Filing and Copying; Text for OCR; Photos; Photos (High Quality); Photos (Quick Scan); Custom; Draft Copy or Fine Copy.

To change any of the settings for that mode, click the **Modify Settings...** button.

Copy Settings

Brother MFC-830/MFC-840

Copies—Enter the number of copies you want to print.

To change the copy options, click the **Copy Options...** button.

Click the **OK** button to save your Copy settings.

Using ScanSoft™ PaperPort® and TextBridge®

ScanSoft™ PaperPort® for Brother is a document management application. You will use PaperPort® to view and scanned documents. PaperPort® has a sophisticated, yet easy-to-use, filing system that will help you organize your graphics and text documents. It allows you to combine or “stack” documents of different formats for printing, or filing. ScanSoft™ PaperPort® can be accessed through the ScanSoft™ PaperPort® program group. See On-Line Documentation for Multi-Function Link® Pro on the CD-ROM.

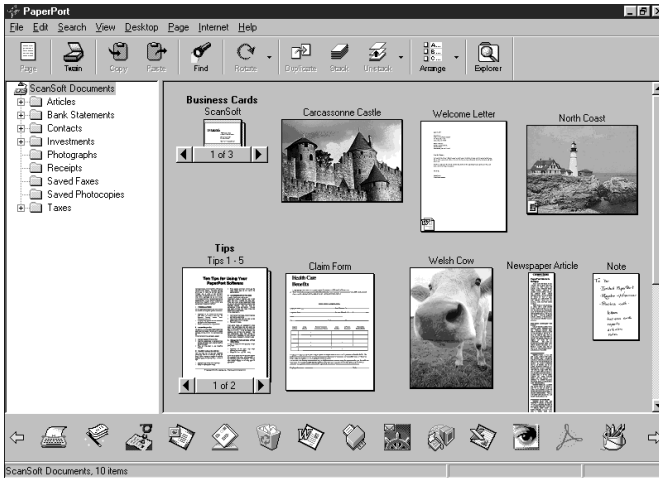

The complete ScanSoft™ PaperPort® Owner’s Manual, including ScanSoft™ TextBridge® OCR, is in the On-Line Documentation on the CD-ROM. This chapter is only an introduction to the basic operations.

Viewing Items in ScanSoft™ PaperPort®

ScanSoft™ PaperPort® provides several ways to view items: **Desktop View** displays a **thumbnail**, a small graphic that represents each item in a Desktop or folder. Items in the selected folder appear on the PaperPort® Desktop. You can see PaperPort® items (MAX files) and non-PaperPort® items (files created using other applications). Non-PaperPort® items include an icon that indicates the application that was used to create the item; a non-PaperPort® item is represented by a small rectangular thumbnail and not an actual image.

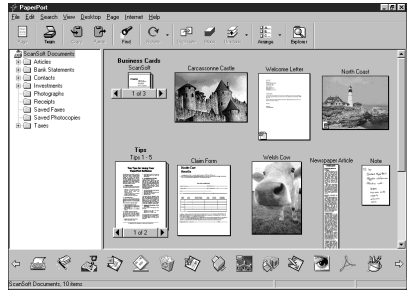

Desktop View displays items as thumbnails

Page View displays a close-up of a single page and you can open a PaperPort® item by double-clicking on it. As long as you have the appropriate application on your computer to display it, you can also double-click a non-PaperPort® item to open it.



Page View displays each item as a full page

Organizing Your Items in Folders

PaperPort® has an easy-to-use filing system for organizing your items. The filing system consists of folders and items that you select to view in Desktop View. An item can be a PaperPort® item or a non-PaperPort® item:

- Folders are arranged in a “tree” structure in the Folder View. You use this pane to select folders and view their items in Desktop View.
- You can simply drag and drop an item onto a folder. When the folder is highlighted, release the mouse button and the item is stored in that folder.
- Folders can be “nested”—that is, stored in other folders.
- When you double-click a folder, its items (both PaperPort® MAX files and other files) appear on the Desktop.
- You can also use Windows® Explorer to manage the folders and items shown in Desktop View.

Links to Many Other Applications

ScanSoft™ PaperPort® automatically recognizes many other applications on your computer and creates a “working link” to them. The Link Bar at the bottom of Desktop view shows icons of those linked applications. To use a link, drag an item onto one of the icons to start the application represented by the icon. This sample Link Bar shows several applications with links to PaperPort®.



If PaperPort® does not automatically recognize one of the applications on your computer, you can manually create a link using the **Create New Link** command. (See PaperPort® in the On-Line-Documentation on the CD-ROM for more information about creating new links.)

Using ScanSoft™ TextBridge® OCR (Converting Image Text to Text You Can Edit)

Software by:  ScanSoft™

ScanSoft™ TextBridge® OCR is automatically installed when you install ScanSoft™ PaperPort® on your computer.

ScanSoft™ PaperPort® can quickly convert the text on a ScanSoft™ PaperPort® item (which is really just a picture of the text) into text that you can edit with a word processing application. PaperPort® uses the optical character recognition application ScanSoft™ TextBridge®, which comes with PaperPort®—**OR**—PaperPort® uses your application if it is already on your computer. You can convert the entire item, or by using the **Copy As Text** command, you can select only a portion of the text to convert.

Dragging an item onto a word-processing link icon starts PaperPort®’s built-in OCR application, or you can use your own OCR application.



Importing Items from Other Applications

In addition to scanning items, you can bring items into PaperPort® in a variety of ways and convert them to PaperPort® (MAX) files in several different ways:

- Print to the Desktop View from another application, such as Microsoft Excel.
- Import files saved in other file formats, such as Windows® Bitmap (BMP) or Tag Image File Format (TIFF).

Exporting Items in Other Formats

You can export or save PaperPort® items in several popular file formats, such as BMP, JPEG, TIFF, or self-viewing. For example, to create a file for an Internet Web site, export it as a JPEG file. Web pages often use JPEG files for displaying images.

Scanning a Document

TWAIN COMPLIANT

The Brother Multi-Function Link[®] Pro software includes a TWAIN compliant scanner driver. TWAIN drivers meet the standard universal protocol for communicating between scanners and software applications. This means that not only can you scan images directly into the PaperPort[®] viewer that Brother included with your MFC, but you can also scan images directly into hundreds of other software applications that support TWAIN scanning. These applications include popular programs like Adobe Photoshop, Adobe PageMaker, CorelDraw and many more.

To choose Brother Multi-Function Link[®] Pro as your scanner driver, select it under the Select scanner—**OR**—Select source option in your software.

Accessing the Scanner

From the PaperPort[®] window, select the **Scan** or **TWAIN** button or from the File drop-down menu choose Acquire. Multi-Function Link[®] Pro's TWAIN dialog box will appear:

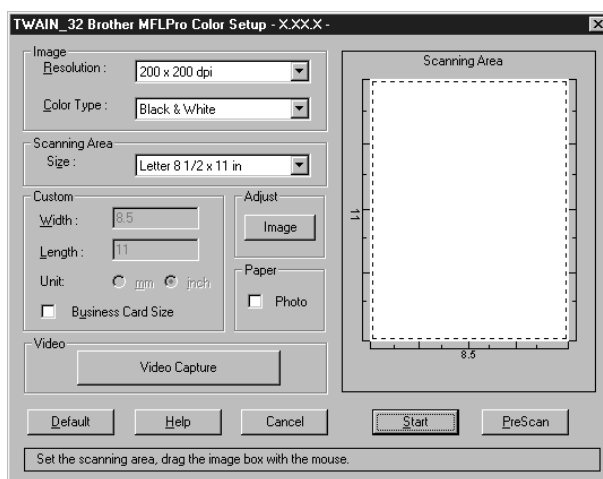

Scanning a Document into the PC

- 1 Place the original face down in the ADF.
- 2 Adjust the following settings, if needed, in the Scanner window:
 - ◆ Resolution
 - ◆ *Colour Type* (Black & White, Grey [Error Diffusion], True Grey, 256 Colour or 24-bit colour)
 - ◆ Size
- 3 Select the **Start** button from the scanner window.
When scanning is completed, press **Cancel** to return to the PaperPort[®] window.

Settings in the Scanner Window

Resolution:

Resolution: Select the scanning resolution from the Resolution drop down list. Higher resolutions take more memory and transfer time, but can achieve a finer scanned image. You can choose:

- ◆ 100 x 100 dpi
- ◆ 150 x 150 dpi
- ◆ 200 x 200 dpi
- ◆ 300 x 300 dpi
- ◆ 400 x 400 dpi
- ◆ 600 x 600 dpi
- ◆ 1200 x 1200 dpi (Black & white, Grey [Error Diffusion]. True Grey and 24-bit colour only)
- ◆ 2400 x 2400 dpi (Black & white, Grey [Error Diffusion]. True Grey and 24-bit colour only)

Colour Type:

Black & White: Set the Colour Type to Black & White for text or line art.

Grey Scale: For photographic images, set the Colour Type to Grey (Error Diffusion) or True Grey.

Colours: Choose either 256 Colour, which scans up to 256 colours, 24-bit colour which scans up to 16.8 million colours. Although using 24-bit colour creates an image with the most accurate colours, the image file will be approximately three times larger than a file created with 256 Colour.

Size:

Set the Size to one of the following:

- ◆ Letter (8 1/2 x 11 in.)
- ◆ A4 (210 x 297 mm.)
- ◆ Legal (8 1/2 x 14 in.)
- ◆ A5 (148 x 210 mm.)
- ◆ B5 (182 x 257 mm.)
- ◆ Executive (7 1/4 x 10 1/2 in.)
- ◆ Business Card (90 x 60 mm.)
- ◆ Custom (User adjustable from 0.35 x 0.35 in. to 8.5 x 14 in.)

After you select a custom size, you can adjust the scanning area further by using the left mouse button to drag the dotted outline of the scanning area. This is required when you want to crop an image when scanning.

To scan business cards, select the Business Card (90 x 60 mm.) size setting and place the business card at the top centre of a carrier sheet.

When scanning photographs or other images for use in a word processor or other graphics application, you should try different settings for the contrast, mode and resolution to see which settings best suit your needs.

Custom:

This section displays the size you selected. To adjust the scanning area size to business card size automatically, check the Business Card Size box.

Adjust:

In the Adjust section, click the **Image** button. The Image screen will appear:

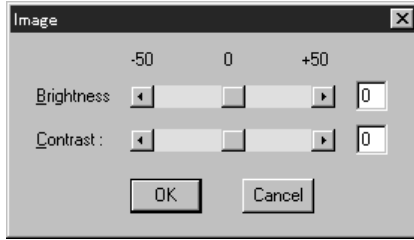

Use the cursor to drag the indicator buttons to the left or right to adjust the Brightness and the Contrast, as needed.

Paper:

Check the Photo box if the image is a photograph.

Video Capture:

The Video Capture button displays the video frame grabber window.

(See *Video Capture from the PC* in this Chapter for details.)

PreScanning an Image

PreScanning allows you to scan an image quickly at a low resolution. A thumbnail version of the image will appear in the Scanning Area. This is only a preview of the image so you can see how it will look. The PreScan button is used to preview an image for cropping any unwanted portions from the image. When you are satisfied with the preview, select the **Start** button from the scanner window to scan the image.

How to use PreScan to adjust an image:

- 1 Insert the original face down in the ADF.
- 2 Select the **PreScan** button.

The entire original will be scanned into the PC and will appear in the Scanning Area of the Scanner window.

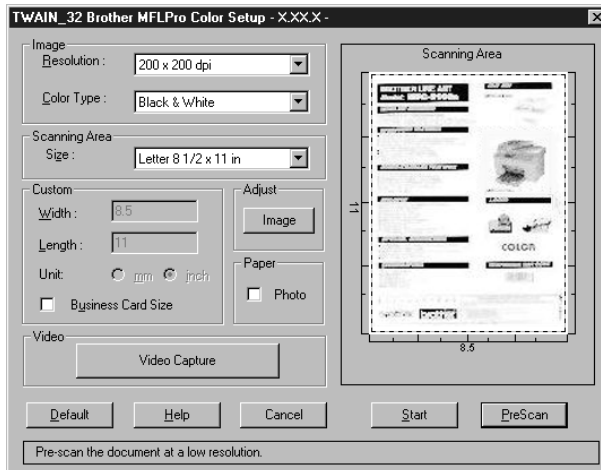

- 3 To crop a portion of the original to be scanned, drag any side or corner of the dotted outline in the Scanning Area with the left mouse button. Adjust the dotted outline until it surrounds only the portion of the original you wish to scan.
- 4 Place the original face down in the ADF.
- 5 Adjust the settings for Resolution, Colour Type and Size in the Scanner window, as needed.
- 6 Select the **Start** button.

This time only the selected area of the original will appear in the PaperPort® window.

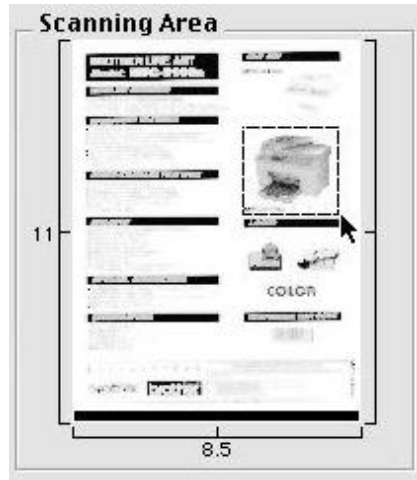

- 7 In the PaperPort® window, use the options available to refine the image. (See PaperPort® for Brother Online Documentation on the CD-ROM for details.)

Video Capture from the PC

Video Capture is the process of isolating a single frame (or picture) from media played on video equipment (such as a video camera or VCR) and then converting that frame into an image file on your PC. Once the frame is an image file, it can be saved, printed, faxed, and inserted into other files.

Connecting Your Video Equipment

Before you can begin to capture a video frame, you must first connect your video equipment to the MFC.

To connect your video equipment:

- 1 Connect your video cable to the connector on your video equipment labeled **VIDEO OUT**.
- 2 Connect the RCA male plug on the other end of the video cable to the RCA female jack on the front of the MFC.

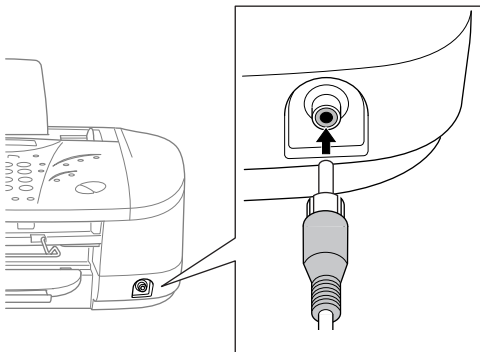

Capturing An Image

You can access Multi-Function Link[®] Pro's TWAIN dialog box from the ScanSoft[™] PaperPort[®] for Brother viewer or from any application that is compatible with TWAIN scanning devices.



It is important that you connect your MFC to your computer before you install the software.

To capture a frame as an image:

- 1 Connect your video equipment to the MFC.
- 2 From PaperPort[®], select **Acquire** from the **File** menu, or click on the

Scan (TWAIN)



icon.

Multi-Function Link[®] Pro's TWAIN dialog box will appear:

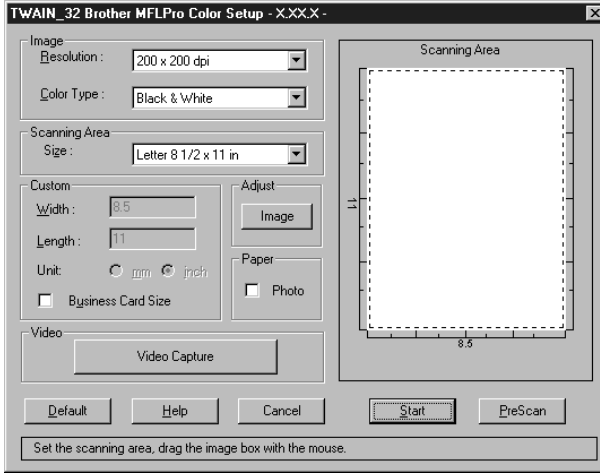

- 3 In the Multi-Function Link[®] Pro Setup (TWAIN) dialog box, click the **Video Capture** button. The Video Capture dialog box will appear:



- 4 Select the **Source** of the video:
- ◆ Live Camera
 - ◆ Tape/VCR
 - ◆ Laser Disc[®]
 - ◆ Digital Camera

- 5 Select the **Type** of video:
 - ◆ Auto-is the most common choice, since the system will determine the Type for you.
 - ◆ Moving
 - ◆ Still
 - ◆ High Quality
 - ◆ Pro Quality-is the highest quality.
- 6 Select the **Preview** type:
 - ◆ B & W-Black and White displays approximately four frames per second.
 - ◆ Colour-displays approximately one frame every two seconds because colour images contain much more data.
- 7 Select the **Size** (dots per inch) of the image file to be created:
 - ◆ 1280 x 960-is the best quality. The image file will be large and take more space on your PC.
 - ◆ 750 x 562
 - ◆ 640 x 480-is suitable for most images.
 - ◆ 320 x 240
- 8 Turn on your video equipment and start running the video.
- 9 When you see the frame you want to capture, click the **Pause** button. The frame will be displayed in the viewer screen section of Multi-Function Link[®] Pro's TWAIN dialog box.
- 10 If you wish to capture the displayed frame, click the **OK** button—**OR**—
If you are not satisfied with the frame that is displayed, resume running the video by clicking the **Pause** button a second time.
The video will resume running.
- 11 Click the **Quit** button to exit the Video Capture dialog box.
- 12 Run PaperPort[®], where a thumbnail image of your frame will be displayed. (See ScanSoft[™] PaperPort[®] Online Documentation on the CD-ROM for details).

18 Using Multi-Function Link® Pro Software

Introduction

This chapter outlines the basics of the Brother software, so you can get started using the Multi-Function Link® Pro software. Detailed installation and setup instructions are in the On-Line Documentation section of the Brother CD-ROM that is included with your MFC.

Multi-Function Link® Pro software for your MFC includes ScanSoft™ PaperPort® for Brother and ScanSoft™ TextBridge®. (See *Using ScanSoft™ PaperPort® for Brother/TextBridge®* in Chapter 17.)

Brother Resource Manager

The Brother Resource Manager application must be running for you to use your MFC with your Windows® computer. Multi-Function Link® Pro software and the MFL Pro Printer Driver automatically load the Resource Manager, as needed. The Resource Manager allows the single bi-directional Parallel port on the MFC to simulate a Communications port for faxing and scanning and to simulate a Parallel port for Windows® GDI printing.

MFC Remote Setup

The MFC Remote Setup application allows you to quickly set up your MFC by taking advantage of the ease and speed of programming on your PC. When you access this application, the settings on your MFC will be downloaded automatically to your PC and displayed on your computer screen. If you change the settings, you can upload them directly to the MFC.

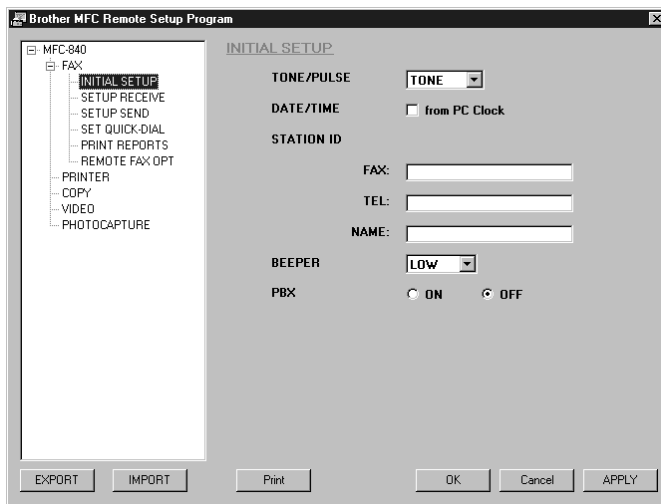

OK

This starts the process of uploading the data to the MFC and exiting the remote setup program. If an error message is displayed enter the correct data again, then click **OK**.

CANCEL

This exits the remote setup application without uploading the data to the MFC.

APPLY

This uploads the data to the MFC, but does not exit the remote setup application.

PRINT

This command prints the selected items on the MFC. You can not print the data until it is uploaded to the MFC. Click **APPLY** to upload the new data to the MFC and click **PRINT**.

EXPORT

This command saves the current configuration settings to a file.

IMPORT

This command reads the settings from a file.

Introduction



The PhotoCapture Centre™ feature requires a USB cable to connection to your PC and will work only with Windows® 98, 98SE, and 2000 Professional.

- 1 Insert a SmartMedia™ or CompactFlash™ card into your MFC.
- 2 In Windows® Explorer on your PC, double-click the Removable Disk icon.
The files and folders that are on the media card will be displayed on your PC screen.

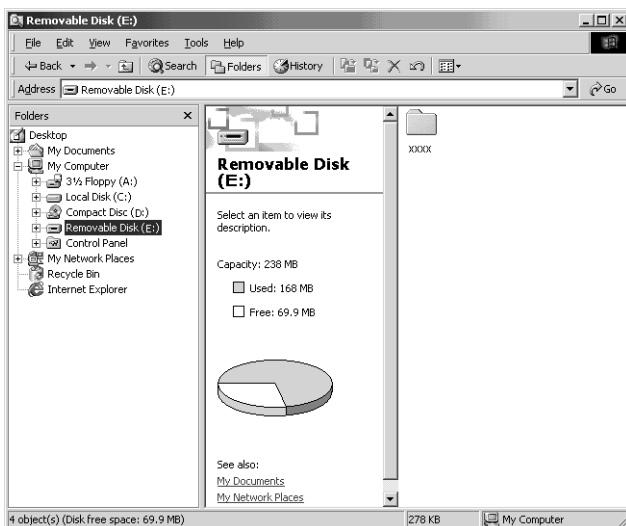

If both media cards are inserted at the same time, the PhotoCapture Centre™ will read only the card that was installed first. To have access to the other card, you must first remove both cards, then insert the media card you wish to access.



Do not unplug the power cord, USB cable or remove a SmartMedia™ or CompactFlash™ card from the MFC while the MFC is reading the card (LED is flashing). You can loose data or damage the card.



While the MFC is printing from the PhotoCapture Centre™ function, the PC can not access the PhotoCapture Centre™ for another operation.

Set up Your USB Equipped Apple® Macintosh® G3, G4 or iMac™ with Mac OS 8.5/8.51/8.6/9.0



Before you can connect the MFC to your Macintosh®, you must purchase a USB cable that is no longer than 6 feet (1.8 meters). Attach the bundle filter core and cable tie to it.

To work with your MFC, your USB-Equipped Apple® Macintosh® must be set up with Mac OS 8.5/8.51/8.6/9.0. (The Brother Scanner Driver works only with Mac OS 8.6/9.0)

Notice to Computer Users

A small filter core and cable tie are enclosed in a vinyl bag with your MFC. **PLEASE SAVE THESE PARTS.** You will need them in the future if you connect the MFC to a Computer. For optimal performance, use a USB Cable with the enclosed Filter Core and Cable Tie.

When you use a Macintosh® with your MFC, please attach the enclosed Filter Core to a USB Cable. (See *Using a USB Cable to Connect the MFC to the PC (Using Windows® 98, 98SE and Windows® 2000 Professional Only)* in Chapter 13.)

Installing the Brother Printer and Scanner Drivers

- 1 Turn on the power to your Macintosh and wait for the startup process to be completed.
- 2 Insert the Brother CD-ROM into your CD-ROM drive. The window below will appear automatically.
- 3 To install the Printer and Scanner Drivers, click **MFL Pro Driver Installer**.
- 4 After installation is completed, connect a standard USB cable to both the MFC and the Macintosh.

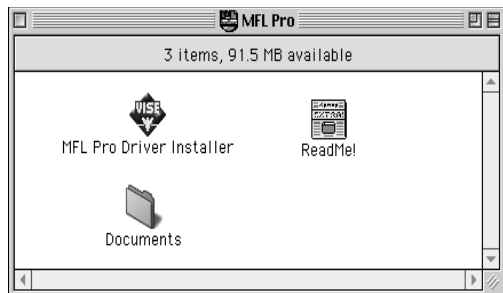

Restart your Macintosh® so it can recognize the new drivers.

Using Brother Printer Driver with your Apple® Macintosh®

To select the Printer:

- 1 From the Apple menu, open the **Chooser**.

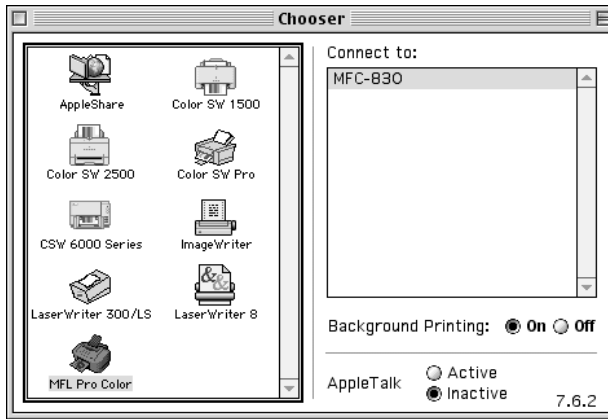

- 2 Click the printer driver you installed to highlight it. On the right side of the Chooser, click the printer to which you want to print. Close the Chooser.

To print the document:

- 3 From application software such as PaperPort®, click **File** menu and select **Page Setup**. You can change the settings for **Paper Size**, **Paper Thickness**, **Paper Source**, **Orientation**, and **Scaling**, then click **OK**.

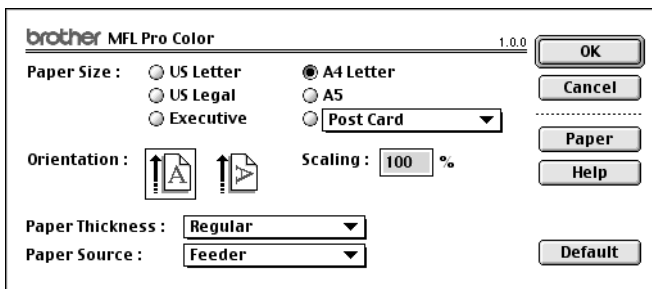

- 4 From application software such as PaperPort, click **File** menu and select **Print**. Click **Print** to start printing.

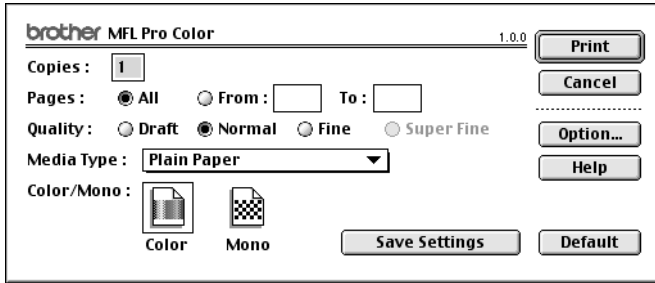

If you want to change **Copies**, **Pages**, **Quality**, **Media Type** and **Colour/Mono**, select your settings before clicking **Print**. Set **Option** allows you to change **Document**.

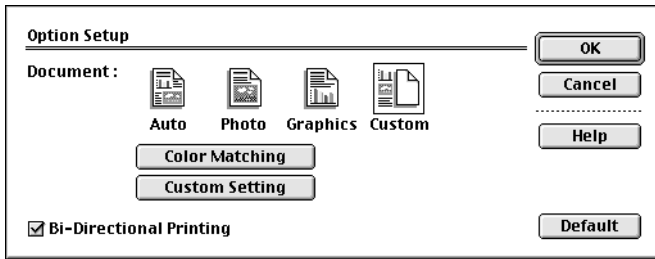

Using Brother TWAIN Scanner Driver with Your Apple® Macintosh®

The Brother MFC software includes a TWAIN Scanner driver for Macintosh®. This Macintosh® TWAIN Scanner driver can be used with application that supports the TWAIN specification. You can use PaperPort for scanning.

Accessing the Scanner

Run your PaperPort® software. You will see the PaperPort® icon in the upper right hand corner of your screen. The first time you use the Brother TWAIN driver, set it as the default by choosing the “**Select Source**”, then click the **PaperPort** icon. Afterward, for each original you scan choose “**Acquire Image**” by clicking the **PaperPort** icon. The Scanner setup dialog box will appear.

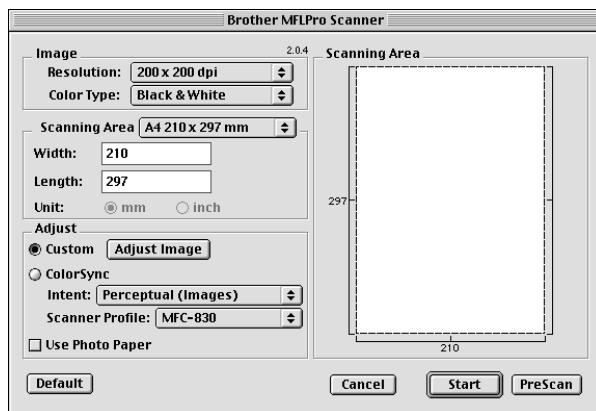

Scanning a Document into Your Macintosh G3, G4 or iMac

- 1 Place the original in the ADF.
- 2 Adjust the following settings, if needed, in the scanner setup dialog box:
 - Resolution*
 - Colour Type*
 - Brightness*
 - Contrast*
 - Scanning Area*
- 3 Click **Start**.

When scanning is finished, the image will appear in your graphics application.

Settings in the Scanner Window

Image

Resolution

Choose the scanning resolution from the Resolution pop-up menu. Higher resolutions take more memory and transfer time, but can achieve a finer scanned image. (Each model has different resolutions. See Specification in Chapter 23.)

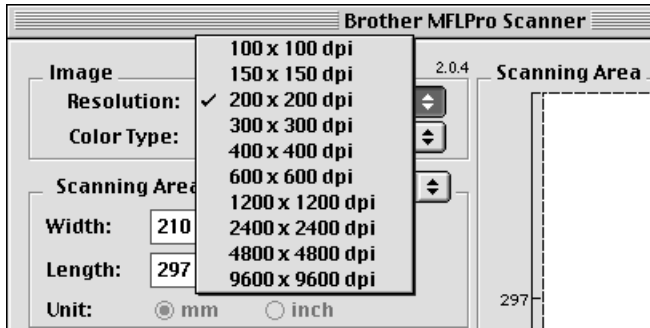

Colour Type

Black & White—Set the image Type to Black&White for text or line art. For photographic images, set the image type to Grey (Error diffusion) or True Grey.

Grey (Error Diffusion)—is used for documents that contain photographic images or graphics. (Error Diffusion is a method for creating simulated grey images by placing black dots in a specific matrix instead of true grey dots.)

True Grey—also is used for documents containing photographic images or graphics. This mode is more exact because it uses up to 256 shades of grey. It requires the most memory and longest transfer time.

Colours: Choose either 8 Bit Colour, which scans up to 256 colors, 24-bit colour which scans up to 16.8 million colors. Although using 24-bit colour creates an image with the most accurate colours, the image file will be approximately three times larger than a file created with 256 Colour.

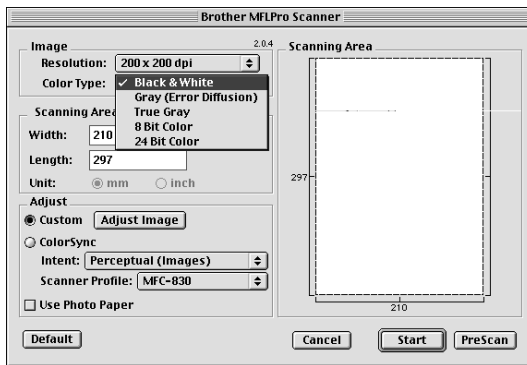

Scanning Area

Set the **Size** to one of the following:

- ◆ Letter (8.5 x 11 inches)
- ◆ A4 (210 x 297 mm)
- ◆ Legal (8.5 x 14 inches)
- ◆ A5 (148 x 210 mm)
- ◆ B5 (182 x 257 mm)
- ◆ Executive (7.25 x 10.5 inches)
- ◆ Business Card (90 x 60 mm)
- ◆ Custom (User adjustable from 0.35 x 0.35 inches to 8.5 x 14 inches)

After you choose a custom size, you can adjust the scanning area. Click and hold the mouse button as you drag the mouse to crop the image.

Width: Enter the width of the custom size.

Length: Enter the length of the custom size.

Adjust Image

Brightness

Adjust the brightness settings to obtain the best image. The Brother TWAIN Scanner driver offers 100 brightness settings (-50 to 50). The default value is 0, representing an “average” setting.

You can set the brightness level by dragging the sliderbar to the right to lighten the image or to the left to darken the image. You can also type a value in the box to set the setting. Click **OK**.

If the scanned image is too light, set a lower brightness value and scan the document again.

If the image is too dark, set a higher brightness value and scan the document again.

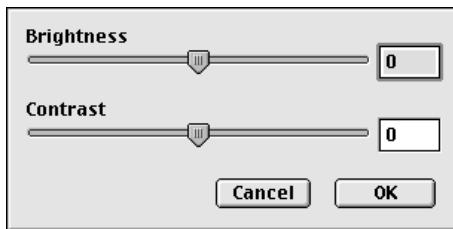

Contrast

The contrast setting is adjustable only when you have selected one of the grey scale settings, but it is not available when Black & White is selected as the grey scale.

Increasing the contrast level (by dragging the sliderbar to the right) emphasizes dark and light areas of the Image, while decreasing the contrast level (by dragging the sliderbar to the left) reveals more detail in grey areas. Instead of using the sliderbar, you can type a value in the box to set the contrast. Click **OK**.

Colour Sync

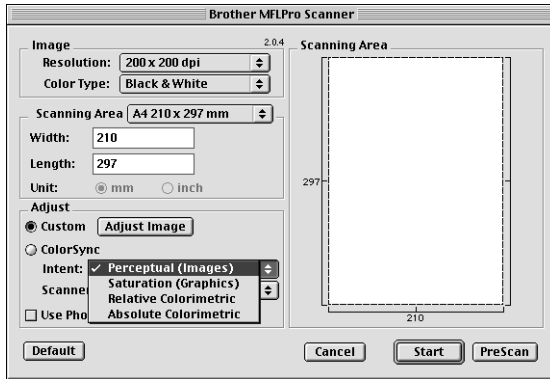

Perceptual (Images) Matching—All the colours of a given gamut are scaled proportionally to fit within another gamut. This intent pretty much maintain the balance between the colours in the image. This intent is the best choice for realistic images, such as scanned photographs.

Saturation (Graphics) Matching—The relative saturation of colours is maintained from gamut to gamut. So basically the colours are shifted to the edge of the gamut to get the most saturated colour possible. Rendering the image using this intent gives the strongest colours and is the best choice for bar graphs and pie charts, in which the actual colour displayed is less important than its vividness.

Relative Colourimetric Matching—The colours that fall within the gamuts of both devices are left unchanged. Some colours in both images will be exactly the same, a useful outcome when colours must match quantitatively. What that means is that if the colour is inside the gamut, it will stay the same colour. However, if the colour is outside the gamut, it will be mapped to the edge of the gamut. This intent is best suited for logos or “spot colours” where colour must match.

Absolute Colourimetric Matching—A close appearance match may be achieved over most of the tonal range, but if the minimum density of the idealized image is different from that of the output image, the areas of the image that are left blank will be different. Colours that fall within the gamuts of both devices are left unchanged.

Scanner Profile

Select your Brother MFC.

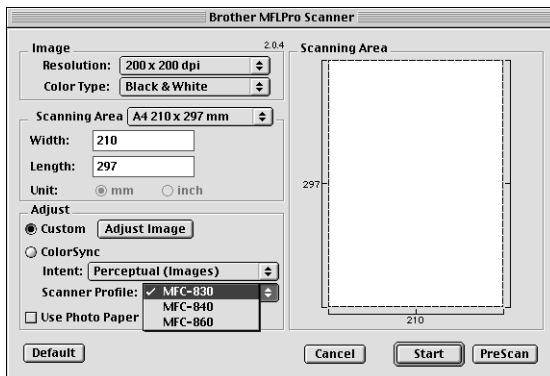

PreScanning an Image

PreScanning allows you to scan an image quickly at a low resolution. A thumbnail version will appear in the Scanning Area. This is only a preview of the image, so you can see how it will look. The PreScan button is used to preview an image for cropping any unwanted portions from the image. When you are satisfied with the preview, click Start to scan the image.

1 Insert the original face down in the ADF.

2 Click **PreScan**.

The entire original will be scanned into your Macintosh G3 or iMac and will appear in the Scanning Area of the Scanner dialog box:

3 To scan a portion of the prescanned image, click and drag the mouse to crop it.

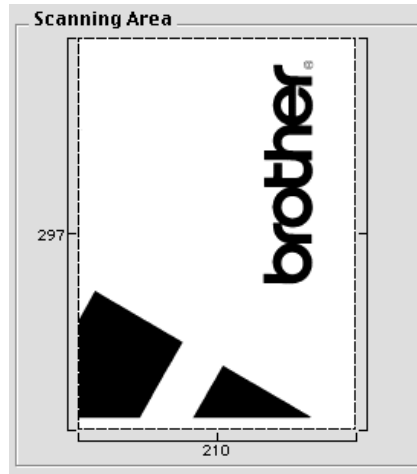

4 Insert original in the ADF of the Brother MFC again.

5 Adjust the settings for Resolution, Colour Type (Grey Scale), Brightness, Contrast, and Size in the Scanner Setup dialog box, as needed.

6 Click **Start**.

This time only the selected area of the original will appear in the Scanning Area.

7 In your editing software application, refine the image as usual.

Error Messages

As with any sophisticated office product, errors may sometimes occur. If this happens, your MFC often identifies the problem and displays an error message. The table below explains the most common error messages.

ERROR MESSAGE	CAUSE	ACTION
CHECK PAPER	MFC is out of paper.	Add paper to cassette, or install cassette properly then press Start .
COMM.ERROR	Poor phone line quality caused communication error.	Try the call again. If problem continues, call Telephone Company to check your phone line.
CONNECTION FAIL	You tried to poll a fax machine that is not in Polled Waiting mode.	Verify the other party's polling setup.
COOLING DOWN	The print head has overheated.	Unplug the MFC and wait 30 minutes for it to cool.
COVER OPEN	Control panel cover or top cover is not closed completely.	Open, then close the covers.
DISCONNECTED	The other party or other party's fax machine terminated the call.	Try to transmit, calling the other party to see what happened or receive again.
DOCUMENT JAM	Documents were not inserted or fed properly, or document was longer than 90cm.	See Document Jam in this chapter.
INK EMPTY XXXX	One or more of the ink cartridges is out of ink.	Replace the ink cartridges. See Replacing the Ink Cartridges in this chapter.
MACHINE ERROR XX	MFC has a mechanical problem	Cut the power off. Then contact your Brother dealer for service.
MEDIA ERROR	You inserted a media card that is either bad or not formatted or there is a problem with the media drive.	Remove the media card. (See <i>Walk-Up Photo Capture Centre™ (For MFC-840 only)</i> in Chapter 12.).
MEMORY FULL	The data is too large for the MFC's memory.	(See <i>Memory Full Message</i> in Chapter 10.)
NEAR EMPTY XXXX	One or more of the ink cartridges is running out of ink where XXXX shows the colour.	Order a new ink cartridge now.
NO FILE	The media card in the media drive does not contain a .JPG file, or the DPOF print file on the media card selects a .JPG image that is not on the Card.	(See <i>PhotoCapture Centre™ Requirements</i> in Chapter 12.)

ERROR MESSAGE	CAUSE	ACTION
NO RESPONSE/ BUSY	The number you dialled does not answer or is busy.	Verify the number and try again.
NOT ASSIGNED	You tried to access a One Touch or Speed Dial number that is not programmed.	Set up the One Touch or Speed Dial number. (See <i>One Touch Dialling</i> in Chapter 4. Also see <i>Speed Dialling</i> in Chapter 4.)
PRINTER JAM	The recording paper is jammed in the MFC.	See Printer Jam in this chapter.
SET CARTRIDGES	An ink cartridge is not installed properly.	Re-install the ink, seating it properly. (See <i>Replacing the Ink Cartridges</i> in this Chapter.)
WARMING UP	The print head detects low temperature.	Wait until the MFC warms up.

Clearing Jams

Document Jam

If the original is jammed, follow the steps as below.

Document Jam inside front of control panel.

- 1** Remove any paper from the ADF that is not jammed.
- 2** Pull the jammed original out toward the front of the MFC.
- 3** Press **Stop**.

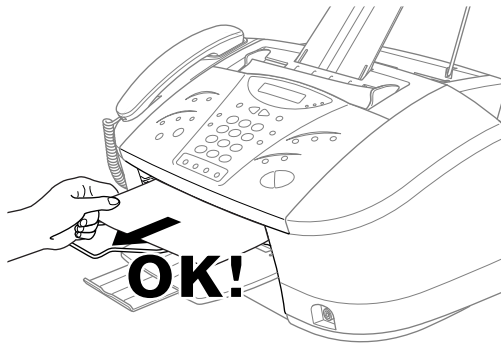

Document Jam inside back of control panel.

- 1 Remove any paper from the ADF that is not jammed.
- 2 Lift the control panel cover.
- 3 Pull the jammed document out toward the back of the MFC.
- 4 Close the control panel cover.

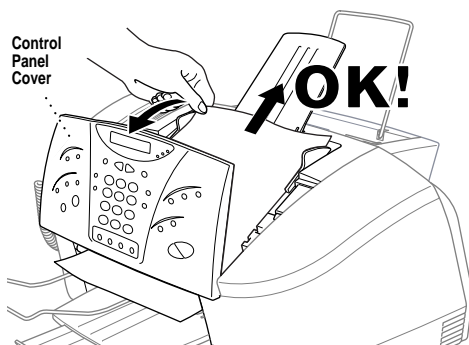

Printer Jam or Paper Jam

Remove the jammed paper depending on where it is jammed in the MFC.

Paper is jammed in the multi-purpose sheet feeder.

- 1 Remove any paper from the multi-purpose Sheet Feeder that is not jammed.
- 2 Pull the jammed paper upward and remove it.

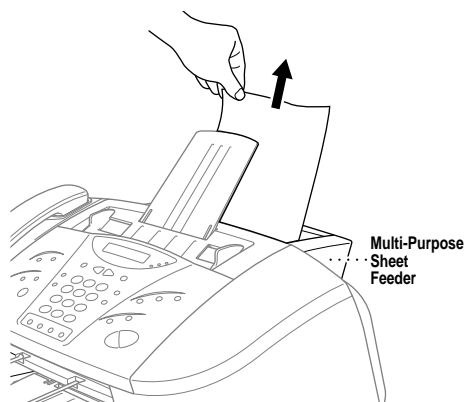

Paper is jammed inside the MFC.

- 1 Open the control panel cover by pulling it toward you, then lift the top cover toward the back.
- 2 Remove the jammed paper.
- 3 Close the control panel cover and top cover.

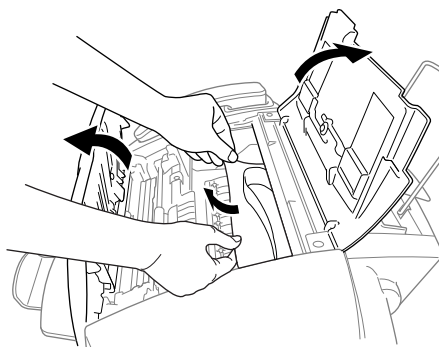

Paper is jammed inside front of MFC.

- 1** Pull the paper toward you.

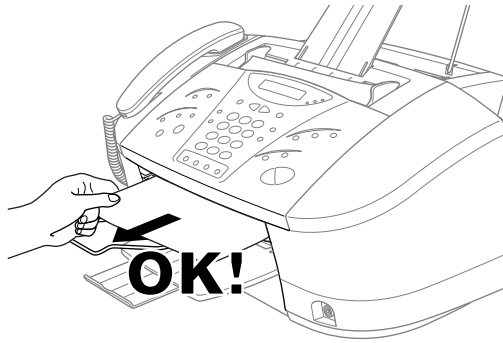

Paper is jammed inside back of MFC.

- 1** Open the jam clear cover.
- 2** Pull the paper out of the back of the MFC.
- 3** Close the jam clear cover.
- 4** Press **Stop**, then press **Start**.

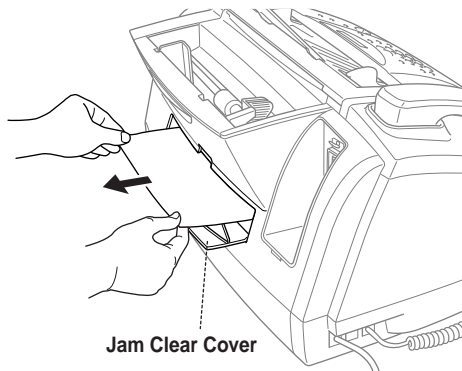

Difficulty with Operation

If you think there is a problem with your MFC, make a copy first. If the copy looks good, the problem is probably not your MFC. Check the chart below and follow the troubleshooting tips.

DIFFICULTY	SUGGESTIONS
Printing or Receiving Faxes	
Condensed Print and Horizontal Streaks / Top and Bottom of Sentences Are Cut Off	If your copy looks good, you probably had a bad connection, with interference on the phone line.
Poor Quality Print	Make sure the Printer Driver matches the type of paper you are using (See <i>The Quality/Colour Tab</i> in Chapter 15.) If you are using plain paper, try using recommended special paper. (See <i>Brother Paper</i> in Chapter 23.) Don't handle the paper until the ink is dry. Adjust the Vertical Alignment. (See <i>Aligning Ink Cartridges</i> in this Chapter.)
Smudged Stain on the top centre of the printed page.	Press the purple paper thickness adjustment lever down. (See <i>Load paper in the paper cassette</i> in Preparation and Simple Use Guide.)
Printing Too Dark or Too Light	Make sure your ink cartridges are fresh and within their expiry dates. Cartridge expiry dates are printed on the package. Make sure the Printer Driver matches the type of paper you are using (See <i>The Quality/Colour Tab</i> in Chapter 15.) Try using recommended special paper (See <i>Brother Paper</i> in Chapter 23.) The recommended environment for your MFC is between 15 °C to 30 °C.
Printing Appears Dirty or Ink Seems to Run	Make sure you are using the recommended paper (See <i>Brother Paper</i> in Chapter 23.) Don't handle the paper until the ink is dry. The recommended environment for your MFC is between 15 °C to 30 °C.
White Lines in Text or Graphics	Clean the print head (See <i>Cleaning the Print Head</i> in Chapter 21.)
Stains Appear on the Reverse Side or at the Bottom of the Page	Make sure the Printer Platen and Pick Up Roller are not dirty with ink mist. (See <i>Regular Maintenance</i> in Chapter 21.)
Vertical Black Lines When Receiving	The sender's scanner may be dirty. Ask the sender to make a copy to see if the problem is with the sending machine. Try receiving from another fax machine.
Received colour fax prints only in B & W.	Replace the colour ink cartridges that are empty or nearly empty. (See <i>Replacing the Ink Cartridges</i> in this Chapter.)

DIFFICULTY	SUGGESTIONS
Phone Line or Connections	
MFC Does Not Answer When Called	Make sure the MFC is in the correct receiving mode for your setup (either Fax, Fax/Tel). Check for dial tone. If possible, call your MFC to hear it answer. If there is still no answer, check the telephone line cord connection. Connect a standard telephone handset to the MFC telephone socket. If there is no ringing when you call your MFC, call your Telephone Company to check the line.
No Dial Tone on the Handset	Lift the handset. If you hear no dial tone, check telephone line cord connections at the MFC and wall socket. Check that the handset is connected to the MFC's handset socket. Test the wall socket with another single line telephone. If no dial tone on the wall socket, call your Telephone Company.
Sending Faxes	
Poor Transmitting Quality	Try changing your resolution to FINE or S.FINE . Make a copy to verify your MFC's scanner operation.
Transmission Verification Report says "Result:NG" again.	There is probably temporary noise or static on the line. Try sending the fax. If the problem continues, call the Telephone Company to check your phone line.
Handling Incoming Calls	
Pseudo Ring in F/T Mode	The MFC knows the incoming call is not a fax so it is signaling you to answer the telephone call. Pick up the MFC handset or answer from an extension phone and press your MFC's Remote Deactivation Code (default setting is #51).
Transferring a Fax Call to the MFC	If you answered at the MFC, press Start and hang up immediately. If you answered at an extension phone, press your Remote Activation Code (default setting is *51). When your MFC answers, hang up.
Custom Features on a Single Line	If you have, Voice Mail, alarm system or any other on a single phone line with your MFC, it may create a problem sending or receiving fax data. For example: If you are sending or receiving a fax message while a custom feature signal comes through on the line, the signal can temporarily interrupt or disrupt the fax data. Brother's ECM feature should help overcome this problem. This condition is related to the telephone system industry, and is common to all devices that send and receive information on a single, shared line with custom features. If avoiding a slight interruption is crucial to your business, a separate line with no custom features is recommended.
Printer Difficulties	
Horizontal lines appear in Text or Graphics.	Clean the print head (See <i>Cleaning the Print Head</i> in Chapter 21.)

DIFFICULTY	SUGGESTIONS
An image from the PhotoCapture Center™ can be printed only partially or not at all.	Make sure the image is not corrupted and that it has a .JPG extension that is compliant with Exif version 2. (See <i>PhotoCapture Centre™ Requirements</i> in Chapter 12.)
Scanning Difficulties	
TWAIN Errors appear while scanning.	Make sure the Brother TWAIN Driver is selected as the primary source. In PaperPort®, click File Select Source, highlight the Brother TWAIN Driver and click Select.
Software Difficulties	
Cannot perform '2 in 1' printing.	Check if the paper size setting in the application and in the printer driver are the same.
Cannot print when using Paint Brush.	Try setting the Display setting to '256 colours'.
Cannot print when using Adobe Illustrator.	Try to reduce the printing resolution.
Thick line and thin line appear alternately.	Turn OFF 'Bi-Directional Printing' from the 'Quality/Colour' tab in the printer driver.
There are some dense lines.	Turn ON 'Reverse Order' from the 'Paper' tab in the printer driver.
When using ATM fonts, some characters are missing or some are printed in the same place.	If you are using Windows®95/98, select 'Printer Settings' from the 'Start' menu. Open 'Brother XXXX' properties. Click 'Spool Setting' on the characters 'Details' tab. Select 'RAW' from 'Spool Data Format'.
When using Power Point or Excel, hatch pattern is not what you are expecting.	Open the 'Quality/Colour' tab in the printer driver, and change the 'Document' type to 'Photo'.
Printing is slow.	In the Quality/Colour tab of the Print dialog box, select Auto in the Document section.
Colour enhance is not working correctly.	If the image data is not full colour (Such as 256 colour) in your application, Colour enhance does not function. Please use at least 256 colour data with the Colour enhance feature.

DIFFICULTY	SUGGESTIONS
<p>“Unable to write to LPT1” or “LPT1 already in use” Error Message appears.</p>	<p>1. Make sure the MFC is on (plugged into the AC outlet) and that it is connected directly to the computer using the IEEE-1284 bi-directional parallel cable. The cable must not go through another peripheral device (such as a Zip Drive, External CD-ROM Drive, or Switch box).</p>
<p>“MFC is Busy” or “MFC Connect Failure” Error Message appears.</p>	<p>2. Make sure the MFC is not displaying an error message on the LCD Display.</p> <p>3. Make sure no other device drivers, which also communicate through the parallel port, are running automatically when you boot up the computer (such as, drivers for Zip Drivers, External CD-ROM Drive, etc.) Suggested areas to check: (Load=, Run=command lines in the winanl file or the Statup Group).</p> <p>4. Check with you computer manufacturer to confirm that the computer’s parallel port settings in the BIOS are set to support a bi-directional machine, i.e., Parallel Port Mode-ECP</p>
<p>Video Capture</p>	
<p>LCD does not show “VIDEO: PRESS COPY CAPTURE READY”</p>	<p>Check the video cable connection to the MFC’s RCA pin jack. Check that the video equipment is sending a signal (video equipment is turned on and set to the correct setting).</p>

How to Improve Print Quality

Test Print

If the quality is not satisfactory, first print a test page to help you identify settings you may want to change.

- 1 Press **Menu**, **2**, **1**, and press **Set**.
- 2 Press **Start**. The MFC begins printing.
- 3 Press **Stop** to exit.

Cleaning the Print Head

Clean the print head if you get a horizontal line in the text or graphics on your printed documents. You can clean the four colour (black, cyan, yellow, magenta) print heads (or a single colour) using the Ink Management key.



Do NOT clean the print head by touching it with your hand or a cloth.

- 1 Press **Ink Management**.
- 2 Press **1** to choose **1.CLEANING**.
- 3 Press **◀** or **▶** or to choose the colour you want to clean.
- 4 Press **Set** to clean the print head automatically.

When cleaning is finished, the MFC will go back online automatically.



Do NOT touch the print head. Touching the print head may cause permanent damage and may void the print head's warranty.

Aligning Ink Cartridges

This feature allows you to check and align the ink cartridges to assure best print quality. Make sure there is paper in the cassette before you start the alignment procedure.

- 1 Press **Menu**, **2**, **2**.
- 2 Press **Start**. The MFC prints a sample page.

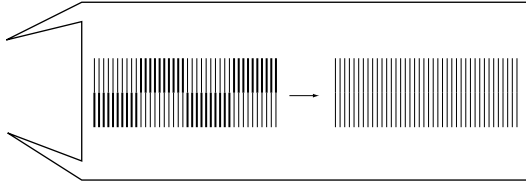
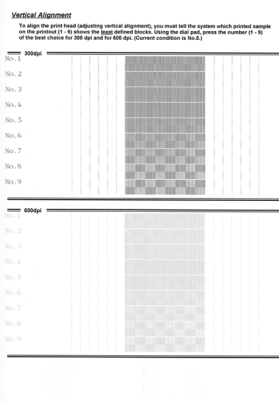

Study the alignment page and decide which sample numbers show the most evenly printed ink lines for 300 and 600 dpi. The screen displays

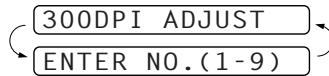

- 3 Using the dial pad, enter the level of adjustment needed for 300 dpi (1 to 9).
- 4 The screen displays
- 5 Using the dial pad, enter the level of adjustment needed for 600 dpi (1 to 9).
- 6 Print another sample Test Print and check it (See *Test Print* in this Chapter.)
- 7 Press **Stop** to exit.

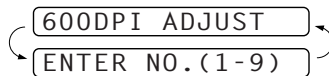

Packing and Shipping the MFC

Whenever you transport the MFC, use the packing materials that came with your MFC. If you do not pack the MFC correctly, you could void your warranty.

- 1 Unplug the MFC from telephone wall socket.
- 2 Unplug the MFC from the AC outlet.



Do not unplug the MFC after a print job until you hear the final click.

- 3 Remove the recording paper wire extension, recording paper support, document tray, document plastic extension, and handset, and pack them.



Please remove the ink cartridges and fit the yellow shipping cover. Damage to your print head resulting from packing without the yellow shipping cover will invalidate your warranty.

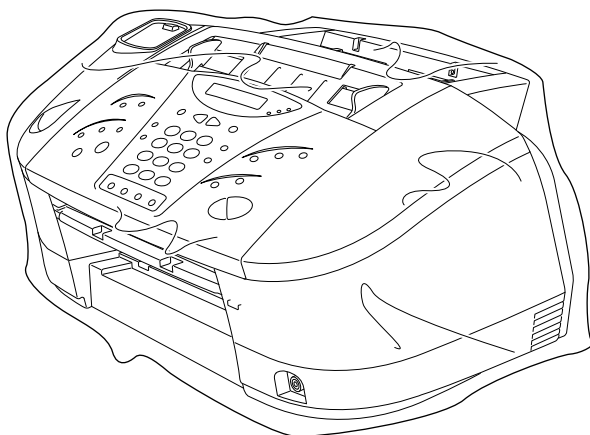

- 4** Wrap the MFC in the plastic bag and place it in the original carton with the original packing material.

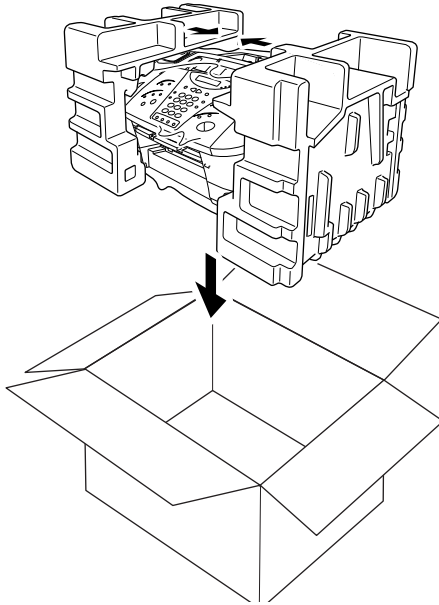

- 5** Place additional parts (such as cords and trays) and documents (such as your manual) into the carton.

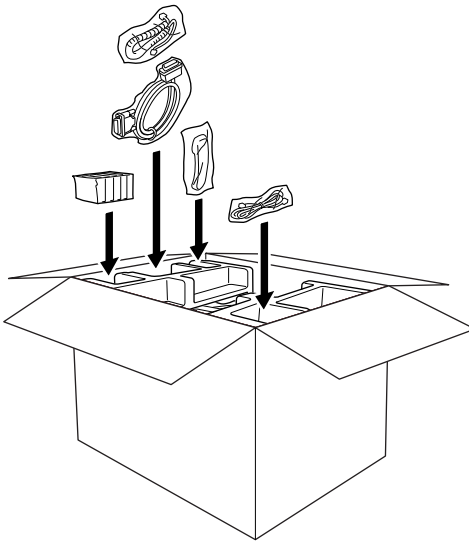

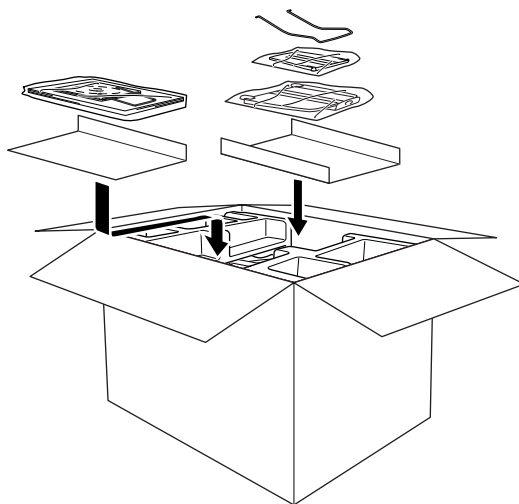

6 Close the carton.

Regular Maintenance

Cleaning the Scanner

Unplug the MFC and open the control panel cover and lift the top cover. Clean the flat white pressure bar and the glass strip under the bar with isopropyl alcohol on a lint-free cloth. If the screen still displays a scanner error, please contact your Brother dealer for service.

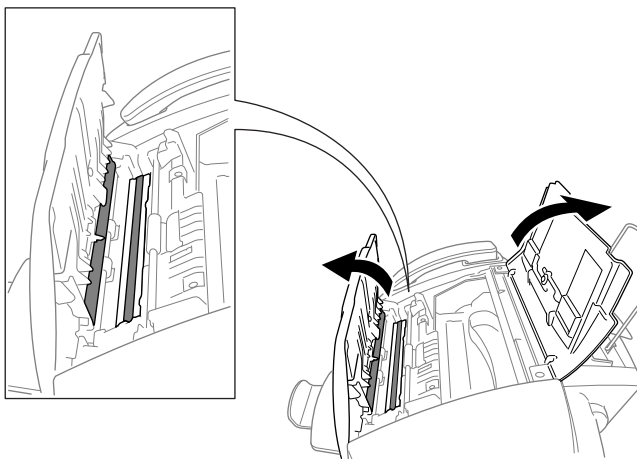

Cleaning the MFC Printer Platen

When you want to clean your MFC printer platen, wipe it with a lint free cloth that is dry or lightly moistened with isopropyl alcohol.

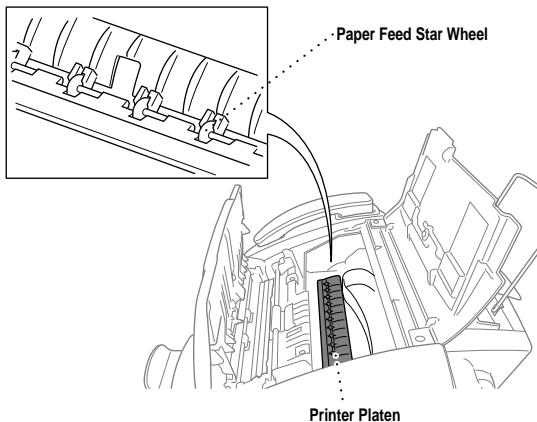

- Be sure to unplug the MFC from the main power outlet before cleaning the printer platen.
- Be careful not to touch the paper feed star wheels and flat cable.

Replacing the Ink Cartridges

Your MFC is equipped with an ink dot counter that automatically monitors the ink level in each colour cartridge. When the counter detects an ink cartridge is running out of ink, the MFC will notify you with a message on the LCD.

The display shows you which colour cartridges are low or empty. Be sure to follow the display prompts so you replace the colour cartridges in the appropriate order.

When the ink cartridges are running low, you must use Ink Management to begin the cartridge replacement (Steps 1–3). If the ink is empty, skip to Step 4.

1 Press **Ink Management**.

2 Press ◀ or ▶ to choose **2. REPLACE INK**, and press **Set**.

If one or more ink cartridges are empty, for example Black, the screen displays **INK EMPTY BLACK** and **PLS OPEN COVER**.

3 Open Control panel cover and lift the top cover.

- 4 Remove the ink cartridge by pulling it toward you and lifting it up and then out of the print head.

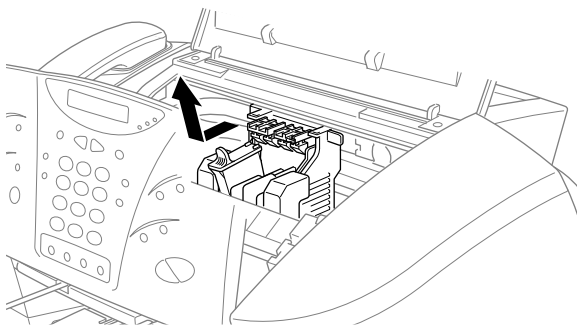

- 5 Open the new ink cartridge bag for the colour on the display and remove the ink cartridge.
- 6 Hold the ink cartridge as shown in the illustration, and remove the sealing tape from the side of the ink cartridge. Carefully peel the tape in the direction away from you.

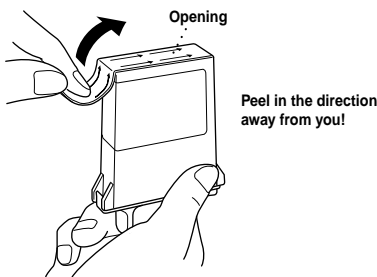

To prevent spilling ink and staining your hands and clothing, remove the sealing tape gently.

- 7 Each colour has its own correct position. Insert each new ink cartridge into the carriage using the colour indicator on the cartridge holder as a guide.
- 8 After installing the ink cartridges, close the top cover and control panel cover. Your MFC prepares for a “head cleaning” and goes online. The display screen prompts you to verify a new ink cartridge was inserted for each colour you removed. Example: **DID YOU CHANGE BLACK 1. YES 2. NO.**
- If the ink cartridge you installed is not a brand new one, please be sure to select **2.**
- 9 For each new cartridge, press **1** on the keypad to reset the ink dot counter for that colour automatically. (The ink dot counter enables the MFC to notify you when a colour is running low.)
- The MFC will enter a cleaning cycle for approximately three minutes for each replaced cartridge. The display screen alternately shows **CLEANING.**
- When the MFC completes the cleaning cycle, the display returns to Standby mode (date and time).



If ink gets in your eyes, irrigate them with water immediately and consult a doctor if you are concerned.



- **DO NOT** remove ink cartridges if you do not need to replace them. If you do so, it may reduce the ink quantity and the printer will not know the quantity of ink left in the cartridge.
- **DO NOT** shake the ink cartridges, because, the ink may spill when you take off the sealing tape.
- If ink stains your body or clothing, wash with soap or detergent immediately.
- If you install an ink cartridge in the wrong colour position, you must clean the print head several times before you start printing, after correcting the cartridge installation, because the colours were mixed.
- Once you open an ink cartridge, install it in the MFC and use it up within six months of installation. Use unopened ink cartridges within two years of production.
- **DO NOT** refill the ink cartridges. Attempting to use refilled cartridges may cause damage to the print head and will void your warranty.



If the **INK EMPTY XXXX** error message is on the display after you have installed ink cartridges, check that the ink cartridges are installed correctly.

Important Safety Instructions

- 1** Read all of these instructions.
- 2** Save them for later reference.
- 3** Follow all warnings and instructions marked on the product.
- 4** Unplug this product from the wall outlet before cleaning. Do not use liquid or aerosol cleaners. Use a damp cloth for cleaning.
- 5** Do not place this product on an unstable surface, stand, or table. The product may fall, causing serious damage to the product.
- 6** Slots and openings in the cabinet and the back or bottom are provided for ventilation; to ensure reliable operation of the product and to protect it from overheating, these openings must not be blocked or covered. The openings should never be blocked by placing the product on a bed, sofa, rug, or other similar surface. This product should never be placed near or over a radiator or heater. This product should not be placed in a built-in installation unless proper ventilation is provided.
- 7** This product should be operated from the type of power source indicated on the label. If you are not sure of the type of power available, consult with your dealer or local power company.
- 8** This machine is designed to be used only with a suitable earthed power outlet. This product is equipped with a 3-wire earthed plug. This plug will fit into only an earthed socket. This is a safety feature. If you are unable to insert the plug into the outlet, contact your electrician to replace your obsolete socket. Do not defeat the purpose of an earthed plug.
- 9** Do not allow anything to rest on the power cord. Do not locate this product where people can walk on the cord.
- 10** Do not place anything in front of the machine that will block received faxes. Do not place anything in the path of received faxes.
- 11** Do not touch a document during printing.
- 12** Never push objects of any kind into this product through cabinet slots, since they may touch dangerous voltage points or short out parts resulting in a risk of fire or electric shock. Never spill liquid of any kind on the product.
- 13** Do not attempt to service this product yourself, because opening or removing covers may expose you to dangerous voltage points and/or other risks. Refer all servicing to service personnel.
- 14** This product has no mains ON/OFF switch. It is therefore highly important that access to the mains plug and the mains socket to which the plug is connected, is never obstructed, in case for some reason the mains power to the machine must be quickly disconnected.

- 15** Unplug this product from the mains power and telephone line sockets, and refer servicing to qualified Service Personnel under the following conditions:
- ◆ When the power cord is damaged or frayed.
 - ◆ If liquid has been spilled into the product.
 - ◆ If the product has been exposed to rain or water.
 - ◆ If the product does not operate normally when the operating instructions are followed. Adjust only those controls that are covered by the operating instructions. Improper adjustment of other controls may result in damage and will often require extensive work by a qualified technician to restore the product to normal operation.
 - ◆ If the product has been dropped or the cabinet has been damaged.
 - ◆ If the product exhibits a distinct change in performance, indicating a need for service.
- 16** We do not advise the use of an extension lead.

IMPORTANT-For Your Safety

To ensure safe operation the three-pin plug supplied must be inserted only into a standard three-pin power point which is effectively grounded through the normal household wiring.

Extension cords used with the equipment must be three-conductor and be correctly wired to provide connection to ground. Incorrectly wired extension cords are a major cause of fatalities.

The fact that the equipment operates satisfactorily does not imply that the power is grounded and that the installation is completely safe. For your safety, if in any doubt about the effective grounding of the power, consult a qualified electrician.

Fax Specifications

Compatibility	ITU-T Group 3 / ITU-T. 30-E (for Colour Fax Function)
Coding system	MH/MR/MMR/JBIG (For MFC-840 only)/JPEG
Modem speed	14400/12000/9600/7200/4800/2400; Automatic Fallback
Document input width	90 mm to 216 mm
Document input length	127 mm to 356 mm
Scanning/Printing width	208 mm
Paper Cassette	100 Sheets (75 g/m ²)
Printer type	Ink Jet
Grey scale	256 levels (Error Diffusion)
Display	LCD, 16 characters
Polling types	Standard, Secure, Delayed, Sequential
Contrast control	Automatic/Light/Dark (manual setting)
Resolution	<ul style="list-style-type: none"> • Horizontal 8 dot/mm • Vertical Standard—3.85 line/mm <ul style="list-style-type: none"> Fine, Photo—7.7 line/mm Superfine, Photo (copy)—15.4 line/mm
Memory Capacity	2MB (up to 100 pages) (MFC-830) 4MB (up to 200 pages) (MFC-840)
One Touch Dial	4 x 2 stations
Speed Dial	50 stations (MFC-830) 100 stations (MFC-840)
Automatic redial	4 times at 2 minute intervals
Auto answer	1, 2, 3 or 4 rings
Communication source	Public switched telephone network
Operating environment	10-35°C (50-95°F)
Best Print Quality	20-33°C (68-91°F)
Power source	220 ~ 240V AC 50/60 Hz
Power consumption	Standby: under 10 watts Peak: under 45 watts
Dimensions	468 x 352 x 228 (mm)
Weight	8kg

* Using ITU-T chart, with JBIG coding (For MFC-840 only) and Standard Resolution.

Printer Specifications

Printing

Print method	Piezo with 64 x 4 nozzles
Resolution	Monochrome/Colour Printing: 1200 x 1200 dots per inch (DPI), 600 x 600 dots per inch (DPI) 300 x 300 dots per inch (DPI), 300 x 150 dots per inch (DPI)
Print speed	up to 12 pages / minute (Mono) up to 10 pages /minute (Colour)
Print width	203.2 mm (8 inches)
Disk-based fonts	35

Controller

Interface	A shielded cable to IEEE 1284 (bi-directional) specification less than 2 m (6.5 feet) long should be used. USB (Universal Serial Bus) Interface that is no longer than 2m (6.5feet).
------------------	---

Print Media

Paper input	Automatic loading from the Feeder or manual loading from the Manual Feed Slot <ul style="list-style-type: none">■ Paper type: Plain paper, coated paper, glossy paper, transparencies, organizer paper and envelopes.■ Paper size: A4, A5, B5, Letter, Legal Executive, envelopes (commercial No. 10, DL, C4, C5) organizer (K, L), Postcard, Photo Width: 148–216 mm (5.8–8.5") Length: 127–356 mm (5–14") Weight: 64–120 g/m² (17–32 lb)■ Maximum feeder capacity: Approx. 100 sheets of 75 g/m² plain paper.
Paper output	Approximately 50 sheets of plain paper (Face up print delivery to the paper output tray) It is recommended that printed sheets are taken from the paper output tray immediately after printing.
Ink	Black and 3 individual colour ink cartridges separate from the print head
Service life of ink cartridge	Approximately 850 pages/Black cartridge at 5% coverage Approximately 410 pages/Colour cartridge at 5% coverage

Compilation and Publication Notice

Under the supervision of Brother Industries Ltd., this manual has been compiled and published, covering the latest product's descriptions and specifications.

The contents of this manual and the specifications of this product are subject to change without notice.

Brother reserves the right to make changes without notice in the specifications and materials contained herein and shall not be responsible for any damages (including consequential) caused by reliance on the materials presented, including but not limited to typographical and other errors relating to the publication.

Trademarks

Multi-Function Link Pro and PhotoCapture Centre are registered trademarks of Brother Industries, Ltd.

Brother is a registered trademark of Brother Industries, Ltd.

Windows and Windows NT are registered trademark of Microsoft in the U.S. and other countries.

Microsoft is registered trademarks of Microsoft in the U.S. and other companies.

Macintosh is a registered trademark, and iMac is a trademark of Apple Computer, Inc.

PaperPort and TextBridge are registered trademarks of ScanSoft, Inc.

Each company whose software title is mentioned in this manual has a Software License Agreement specific to its proprietary programs.

The brother logo is a registered trademark of Brother Industries, Ltd.

IBM, IBM PC and Proprinter are registered trademarks of International Business Machines Corporation.

SmartMedia is a trademark of Toshiba Corporation.

All other brand and product names mentioned in this User's Guide are registered trademarks of their respective companies.

Ordering Accessories and Supplies

For the best quality results use only genuine Brother accessories. These are available from most Brother dealers or alternatively you can contact our mail order department on telephone number 0161 931 2258 or fax number 0161 931 2218.

Description	Item
Ink Cartridge <black>	LC50BK
Ink Cartridge <cyan>(blue)	LC50C
Ink Cartridge <magenta>(red)	LC50M
Ink Cartridge <yellow>	LC50Y
720 dpi High Quality Coated Paper (200 sheets)	BP72CA
Glossy Paper (20 sheets)	BPGLA
Transparencies (ink jet compatible)	BRTRA



Brother Coated Paper is Ink Jet Paper.

Brother Paper

The quality of your document can be affected by the kind of paper you use in the MFC. You can use plain paper, coated paper, transparencies, glossy paper, organizer paper, and envelopes. We recommend testing various papers before purchasing large quantities. For best results, use Brother special coated paper, glossy paper, and transparencies. (See the page next to front page for information about ordering Brother accessories).



When you print on coated paper, transparencies, and glossy paper, be sure to select the correct media in the “Quality/Colour” tab in the printer driver. When using coated paper, transparencies or glossy paper, avoid stacking by removing each page after copying or printing.

Brother paper is manufactured specifically for this MFC, to provide you with optimum print quality.

High Quality Coated Paper for 720 dpi Colour Ink Jet printing—super fine mode (BP72CA for A4)

Colour Ink Jet Transparencies— fine mode (BPTRA for A4)

Colour Ink Jet Glossy Paper— superfine mode (BPGLA for A4)

- Brother coated (ink jet) paper is coated only on one side. Therefore, when loading paper in the paper cassette, make sure that the whiter side (the coated side) is facing up.
- The coated side of glossy paper is shiny. Do not touch the shiny side. Load glossy paper in the feeder with the shiny side facing up toward you.
- DO NOT touch the coated side of the paper or either side of transparencies, because the media absorbs water and perspiration easily, and this might cause decreased output quality.
- For optimum output quality, be sure to use paper appropriate for your resolution setting.
- Store paper in the original bag, and keep it sealed. Keep the paper flat and away from moisture and direct sunlight and heat.
- Transparencies designed for laser printers/copiers may stain your next document. Use only recommended transparencies for ink jet printer.

Paper Specifications for Cassette

Paper Type	Paper Size	Cassette Capacity
Cut Sheet	A4, Letter, Executive	100 Sheets of 75 g/m ²
	Legal	100 Sheets of 75 g/m ²
Coated Paper	A4, Letter	50 Sheets
Transparencies	A4, Letter	20
Glossy Paper	A4, Letter	20
Envelopes	DL, COM-10, C5, B5, Monarch	10
Organizer	K, L	10
Photo	127 X 177.8 mm	10
Post card	106.1 X 152.4 mm	30
Paper Capacity for Feeder Cut Sheet Paper Weight 64 to 120 g/m ² Sheet Feeder: Up to 11 mm/Approximately 100 Sheets of 75 g/m ² Output Stacker: Approximately 50 Sheets of 75 g/m ² Transparencies and glossy paper must be picked up from the paper tray page by page.		



- **Curled or damaged paper may cause paper jams and misfeeds. If the paper is curled, straighten it as much as possible by rolling it in the opposite direction to the curl.**
- **For optimum output quality, we recommend you use only genuine Brother paper.**

Print Area

The Print Area depends on the settings in the application you are using. The figures below show the unprintable areas on cut sheets and envelopes.

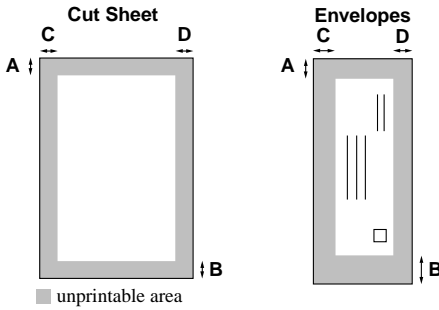

Paper Type	Paper Size		A	B	C	D
Cut Sheet	A4	Fax	3mm	11mm	3.4mm	3.4mm
		Mono Copy				
		Colour Copy				
		Printer	3mm	11mm	2mm	4.8mm
	Executive	Printer	3mm	11mm	3.4mm	3.4mm
Organizer	K, L	Printer	3mm	11mm	3.4mm	3.4mm
Envelopes		Printer	10mm	20mm	3.4mm	3.4mm

Printer depends on the Printer driver.



Do not use the following types of paper and envelopes:

- Damaged, curled, wrinkled, or irregularly shaped paper and envelopes
- Extremely shiny or highly textured paper and envelopes
- Envelopes with clasps
- Envelopes of baggy construction
- Envelopes not sharply creased
- Embossed envelopes
- Paper and envelopes already printed with a laser printer
- Envelopes preprinted on the inside
- Paper and envelopes that cannot be arranged uniformly when stacked

Entering Text

When you are setting certain functions, such as the Station ID, you may need to enter text into the MFC. Most keys on the dial pad have three or four letters printed above them. The keys for 0, #, and * don't have printed letters because they are used for special characters.

By pressing the appropriate number on the dial pad the correct number of times, you can access the character you want.

Press Key	one time	two times	three times	four times	five times
2	A	B	C	2	A
3	D	E	F	3	D
4	G	H	I	4	G
5	J	K	L	5	J
6	M	N	O	6	M
7	P	Q	R	7	P
8	T	U	V	8	T
9	W	X	Y	9	W

Inserting spaces

If you want to enter a blank space, press ► twice.

Making corrections

If you entered a letter incorrectly and want to change it, press ◀ to move the cursor after the last correct letter. Then press **Stop**; all letters above and to the right of the cursor are deleted. Re-enter the correct text and/or digits. You can also back up and type over incorrect letters.

Repeating letters

If you need to enter a character assigned to the same key as the previous character, press ► to move the cursor to the right.

Special characters and symbols

Press the *, #, or 0 key, until the cursor appears under the character/symbol you want to enter. Then press ► or enter the next letter.

0 key Ä Æ Ö Ü À Ç È É 0

* key (space) ! " # \$ % & ' () * + , - . / €

key ; < = > ? @ [] ^ _

Menu Selection Table

If you have a basic understanding of how to program your MFC, you can perform most of the programming settings without the Owner's Manual. To help you understand the function selections, options, and settings that are available, use the Menu Selection Table below.

1. Fax Menus

1. INITIAL SETUP

Function	Description	Factory Set	Chapter
1. TONE/PULSE	Selects the dialling mode.	TONE	Preparation and Simple Use Guide
2. DATE/TIME	Enter date and time for LCD display and to print on transmissions.	01/01 2001 00:00	
3. STATION ID	Program the name, fax number to appear on each transmitted page.	—	
4. BEEPER	Adjust the volume level of the beeps when you press a key, an error occurs or a document is sent or received.	LOW	1
5. PBX	Turn on if PABX (Private Automatic Branch Exchange) is connected to your MFC.	OFF	1
6. CLOCK CHANGE	Adjust the MFC's clock by one hour for summer/winter time.	—	1

2. SETUP RECEIVE

Function	Description	Factory Set	Chapter
1. RING DELAY	Number of rings before the MFC answers in Fax/Tel, Fax or TAD mode.	RING DELAY:02	3
2. F/T RING TIME	Sets the time for "F/T pseudo ring" in Fax/Tel mode.	30	3
3. FAX DETECT	Receive fax messages without pressing the Start key.	ON	3
4. REMOTE CODE	Enter code to activate or deactivate your MFC from a remote location.	OFF (* 51, #51)	7
5. REDUCTION	Reduces size of image.	AUTO	3
6. MEM. RECEIVE	Automatically stores any incoming faxes in its memory if it runs out of paper.	ON	3
7. POLLING RX	You call another fax machine to receive a fax from it.	STANDARD	8

3. SETUP SEND

Function	Description	Factory Set	Chapter
1. COVERPG SETUP	Automatically sends a programmable cover page or prints a sample coverpage.	OFF	6
2. COVERPAGE NOTE	Program customized message for fax cover page.	—	6
3. CONTRAST	Change the lightness or darkness of a fax you are sending.	AUTO	2
4. RESOLUTION	Allows you to change resolutions page by page.	STANDARD	6
5. OVERSEAS MODE	Special setting for international transmissions.	OFF	6
6. CALL RESERVE	You can send a fax, then speak to the person operating the other fax machine or print a sample call back message.	OFF	6
7. TIMER	Set the MFC to send documents later.	—	6
8. POLLED TX	Set Polled Transmission for someone to poll your MFC to receive a fax from you.	STANDARD	8
9. REAL TIME TX	When memory is full, you can send faxes in real time.	OFF	2
0. BATCH TX	Sends all delayed faxes that are to the same fax number and at the same time as one transmission.	OFF	6

4. REMAINING JOBS

Function	Description	Factory Set	Chapter
	Check which jobs are in memory or cancel a delayed fax (timer) or polling job.		6, 8

5. SET QUICK-DIAL

Function	Description	Factory Set	Chapter
1. ONE-TOUCH DIAL	Dial numbers stored in memory by pressing only one key.	—	1
2. SPEED-DIAL	Dial numbers stored in memory by pressing only three keys.	—	1
3. SETUP GROUPS	Set up a Group number for broadcasting.	—	6

6. PRINT REPORTS

Function	Description	Factory Set	Chapter
1. XMIT REPORT	Print confirmation of transmission after each document is sent.	ON+IMAGE	5
2. JOURNAL	Lists information about the last 50 incoming and outgoing faxes.	JOURNAL: OFF	5
3. QUICK-DIAL	Lists names and numbers stored in One Touch and Speed Dial memory (in numerical order).	—	5
4. TEL. INDEX	Alphabetical lists of stored numbers.		5
5. SYSTEM SETUP	Lists various system settings.	—	5
6. MEMORY STATUS	Lists information about memory use.	—	5
7. ORDER FORM	Print accessories order form to your dealer.		5

7. REMOTE FAX OPT

Function	Description	Factory Set	Chapter
1. FAX FWD	Set your fax machine to forward faxes.	OFF	9
2. FAX STORAGE	Store incoming faxes into memory for remote retrieval.	OFF	9
3. REMOTE ACCESS	Set code for retrieving faxes.	159 *	9
4. PRINT DOCUMENT	Print incoming faxes stored in the memory.	—	3

0. MISCELLANEOUS

Function	Description	Factory Set	Chapter
1. BT CALL SIGN	Use with BT Call Sign.	OFF	7
2. TX LOCK	Prohibits most functions except Receiving faxes.	OFF	6

2. Printer Menus

Function	Description	Factory Set	Chapter
1. TEST PRINT		—	21
2. VERTICAL ALIGN	Use these functions when you need to adjust the print quality.	—	21
3. BI-DIR PRINT		ON	14

3. Copy Menus

Function	Description	Factory Set	Chapter
1. PAPER TYPE	Identify the type of paper in the cassette.	PLAIN	10
2. QUALITY	Select Draft, Normal or High copy quality.	NORMAL	10
3. COLOUR ADJUST	Adjust the amount of Red, Green, or Blue in copies.	—	10
4. CONTRAST	Adjust the contrast.	—	10
5. ONE COLOUR	Select a single colour to use, instead of Black, when you use Mono Copy key.	OFF=Black	10

4. Video Menus

Function	Description	Factory Set	Chapter
1. PAPER TYPE	Identify the type of paper in the cassette.	PLAIN	11
2. QUALITY	Select NORMAL or HIGH print	NORMAL	11
3. VIDEO TYPE	Select MOVING or STILL video signal.	MOVING	11
4. PRINT SIZE	Select the size you want the captured frame to print.	(10x7.6)	11
5. COLOUR ADJUST	Adjust the amount of Red, Green, or Blue in Copies.	—	11
6. CONTRAST	Adjust the contrast.	—	11

5. PhotoCapture Centre Menus (Only for MFC-840)

Function	Description	Factory Set	Chapter
1. PAPER TYPE	Identify the type of paper in the cassette.	PLAIN	12
2. QUALITY	Select Normal, High or Draft print.	HIGH	12
3. BRIGHTNESS	Adjust the brightness.	—	12
4. CONTRAST	Adjust the contrast.	—	12
5. COLOUR ADJUST	Adjust the amount of Red, Green or Blue in colour printing.	—	12
6. COLOUR ENHANCE	Adjust the White balance, Sharpness and Colour density of an image.	—	12

About Fax Machines

If you are a first-time fax machine user, fax operation might seem a little mysterious. You will soon get used to the unusual fax tones on your phone line, and be able to send and receive faxes easily.

Fax Tones and Handshake

When someone is sending a fax, the MFC sends fax calling tones, (CNG tones)—soft, intermittent beeps at 4-second intervals. You will hear them when you dial and press **Start**, and they continue for about 40 seconds after dialling. During that time, the sending machine must begin the “handshake” with the receiving machine. Each time you use automatic procedures to send a fax, you are sending CNG tones over the phone line. You will soon learn to listen for these soft beeps each time you answer a phone on your MFC line, so you can know if you are about to receive a fax message.

The receiving fax responds with fax receiving tones—loud, chirping sounds. A receiving fax chirps for about 40 seconds over the phone line, and the screen displays **RECEIVE**. If your MFC is set to the Fax mode, it will answer every call automatically with fax receiving tones. Even if the other party hangs up, your MFC continues to send the “chirps” for about 40 seconds, and the screen continues to display **RECEIVE**. To cancel the receiving mode, press **Stop**.

When your MFC is in Fax/Tel mode, it answers with a short beep. After this beep, the fax machine listens for CNG tones, and then responds with receiving tones if the CNG tones are present. If it is a voice incoming call, the MFC makes an attention sound.

The fax “handshake” is the time in which the sending machine’s CNG tones and the receiving machines “chirps” overlap. This must be for at least 2 to 4 seconds, so the fax machines can understand how each is sending and receiving the fax. The handshake cannot begin until the call is answered, and the CNG tones only last for about 40 seconds after the number is dialled. Therefore, it is important for the receiving machine to answer the call in as few rings as possible. We suggest 2 rings as the standard setting.



When you have an external telephone answering device (TAD) on your MFC line, your TAD will determine the number of rings before the call is answered. Pay special attention to the directions in the Installation chapter for connecting a TAD (or answering machine) to your MFC.

ECM (Error Correction Mode)

The Error Correction Mode (ECM) is a way for the MFC to check the integrity of a fax transmission while it is in progress. ECM transmissions are possible only between machines that both have the ECM feature. If they do, you may send and receive fax messages that are continuously checked for their integrity. Because of this you should send and receive error free documents, thus avoiding the need to resend. Sufficient memory must be available in your MFC for this feature to work.

Glossary

- ADF (Automatic Document Feeder Capacity)** Refers to the number of pages that can be placed in the document feeder and fed one at a time automatically.
- Automatic Fax Transmission** Sending a fax without picking up the handset.
- Automatic Redial** A feature that enables your fax machine to redial the last fax number if the original fax did not go through because the line was busy or there was no answer.
- Backup Print** Sets your MFC to print a copy of faxes that are received and stored in memory.
- Beeper** The sound the keys make when they are pressed, an error occurs or a document has been received or transmitted.
- Beeper Volume** Volume setting for the beep when you press a key or make an error.
- Brightness** Changing the Brightness makes the whole image lighter or darker.
- Broadcasting** The ability to send the same fax message to more than one location.
- Call Back Message** Allows you to send a fax and then leave a message for the other party to call you back.
- Call Reservation** Allows you send a fax and then at the end of transmission, you can talk with the other party.
- Cancel Job** Cancels a programmed job, like Delayed Fax or Polling.
- CNG tones** The special tones (beeps) sent by fax machines during automatic transmission to tell the receiving machine that they are from a fax machine.
- COMM. ERROR (Communication error)** An error during fax sending or receiving, usually caused by line noise or static.
- Coding Method** Method of coding the information contained in a document. All fax machines must use a minimum standard of Modified Huffman (MH). Your fax machine is capable of greater compression method, Modified Read (MR) and Modified Modified Read (MMR), if the receiving machine has the same capability.
- Compatibility Group** The ability of one fax unit to communicate with another. Compatibility is assured between ITU-T Group.
- Contrast** Setting to compensate for dark or light documents, by lightening dark documents or darkening light documents.
- Cover Page** Prints a page at the other party's machine, that contains the sender and recipient's name and fax number, number of pages and comment. You can generate an electronic cover page at the other end with pre-programmed information from memory or you can print a sample cover page to fax with your document.
- Cover Page Message** The comment that is on the Cover Page. This is a programmable feature.
- Delayed Transmission (Not available for Colour fax)** Sends your fax at a later time that day.
- Dual Access (Not available for Colour fax)** Your machine can scan outgoing faxes or scheduled jobs into memory at the same time it is sending a fax or receiving or printing an incoming fax.
- ECM (Error Correction Mode)** Detects errors during fax transmission and resends the parts of the document that had errors.

Electronic Cover Page A preprogrammed cover page that is transmitted from the fax machine's memory, eliminating the need for making up cover pages manually.

Extension Phone A telephone on the fax number that is plugged into a separate wall jack.

External Phone A TAD (telephone answering device) or telephone that is plugged into the socket on the telephone line cord of your MFC.

F/T Ring Time The length of time the MFC rings (when the answer mode setting is Fax/Tel) to notify you to pick up a voice call that has been automatically answered.

Fax/Tel mode You can receive faxes and telephone calls. Do not use Fax/Tel if you are using an external answering machine.

Fax Forwarding (Not available for Colour fax) Sends a fax received in memory to another preprogrammed fax number.

fax tones The signals sent by sending and receiving fax machines while communicating information.

Fine Mode Resolution is 196 x 203 dpi. It is used for small print and graphs.

grey scale The shades of grey available for copying and faxing photographs.

group number A combination of One Touch and/or Speed Dial numbers that are stored on a One Touch Dial key for Broadcasting.

Ink Management button Cleans the print head and / or resets the ink dot counter after replacing an ink cartridge.

Journal Lists information about the last 50 incoming and outgoing faxes. TX means Transmit. RX means Receive.

Journal Period The preprogrammed time period between automatically printed Journal Reports. You can print Journal on demand without interrupting this cycle.

LCD (Liquid crystal display) The display screen on the MFC that shows interactive messages during On-Screen Programming and defaults to the date and time when the machine is idle.

manual fax When you lift the MFC's/external telephone's handset so you can hear the receiving fax machine answer before you press **Start** to begin transmission.

Memory Status List Shows how much memory is being used, how much is left, and the type of messages in memory.

Menu Mode The programming mode for changing the setting of your MFC.

One Touch Dial Keys on the MFC control panel where you can store numbers for easy dialling. You must use a separate key for each number.

Out of Paper Reception Receives faxes into the MFC's memory when the machine is out of paper.

Overseas Mode Makes temporary changes to the fax tones to accommodate noise and static on overseas phone lines.

Pause Allows you to place a 3.5 second delay in the dialling sequence stored.

Photo Mode A resolution setting that uses varying shades of grey for the best representation of photographs.

Polling The process of a fax machine calling another fax machine to retrieve waiting fax messages.

Pulse A form of dialling on a telephone line.

Print reduction Reduces the size of incoming faxes.

- Quick-Dial List** A listing of names and numbers stored in One Touch and Speed Dial memory, in numerical order.
- Real Time transmission** When memory is full, you can send documents in real time.
- Remaining Jobs** You can check which jobs are waiting in memory and cancel jobs individually.
- Remote access** The ability to access your MFC remotely from a touch tone phone.
- Remote activation** allows you to transfer a fax call, answered at an extension phone, to the MFC.
- Remote access code** The four-digit code that allows you to call and access your MFC from a remote location.
- Resolution** The number of vertical and horizontal lines per inch. See: Standard, Fine, Super Fine, Photo, Colour Fax.
- Ring Delay** The number of telephone rings before the MFC answers a call in F/T or Fax mode.
- Ring Volume** Volume setting for the fax machine's ring.
- Scanning** The process of sending an electronic image of an original paper document into your computer.
- Speaker Volume** You can set the volume when your machine is on hook.
- Speed dial** A preprogrammed number for easy dialling. You must press the **Search/Speed Dial** key and #, then two digit code to start the dialling process.
- Standard resolution** 98 x 203 dpi. It is used for regular size text and quickest transmission.
- Station ID** The stored information that appears on the top of faxed pages. It includes the sender's name and fax number.
- Super fine resolution** 392 x 203 dpi. Best for very small print and line art.
- System Setup List** A printed report that shows the current setting of your machine.
- Tel-Index** An electronic, alphabetical listing of stored One Touch, Speed Dial and Group numbers.
- Temporary Setting** You can select certain options for each fax transmission without changing the default settings.
- Timer (Not available for Colour fax)** A feature that lets you program a fax to go out at a certain time, such as Delayed Fax or Delayed Polling Receive.
- Tone** A form of dialling on the telephone line used for Touch Tone telephones.
- Transmission** The process of sending documents over the phone lines from your MFC to the receiving fax machine.
- Xmit Report (Transmission Report)** A listing of each transmission, showing caller ID, date, time, and number of pages.

Index

A

Activation Code	42
Alternating Displays	iii
Answering Machine	13
Assembly	2
Automatic Transmission	7, 21

B

Beeper Volume	18
BI-DIR PRINT	104
Bi-directional	78
Bi-directional Parallel Cable	77
Brightness	62
Broadcasting (Set Up Group)	38
Brother Control Center	112-113
Brother Home Page	101
Brother Paper	166
BT Call Sign	43

C

Call Back Message (Print)	36
Call Reservation	36
Cancelling Job	46
Cassette Capacity	167
Chain Dialling	31
CHECK PAPER	145
Cleaning (Print Head)	153
Clock Change	19
Coated Paper	166
Collate	107
Colour Adjustment	58
COLOUR ENHANCE	70
Colour Enhance	74
Colour Fax	22
COMM.ERROR	145
Computer Requirements	77

Connect (External Telephone Answering Machine)	13
Connect (External Telephone)	14
Connect (Handset)	1
Connect (Power cord)	1
Connect (Telephone line cord)	1
Contrast	21
Control Panel Overview	15
Controller	164
COOLING DOWN	145
Copies	107
Copy (2in1, 4in1, Poster)	55, 56
Copy (Enlarging/Reducing)	53
Copy (Multiple)	52
Copy (Single Colour)	59
Copy Brightness	58
Copy Contrast	58
Copy Operations	52
Copy Quality	53, 56, 58
Copy/Two on One Copy	123
Corrections	169
COVER OPEN	145
Cover Page Message	35

D

Date and Time	6, 9
Deactivation Code	42
Delayed Batch Transmission	37
Dialling Mode (Tone/Pulse)	10
Difficulty	149
Document (Size)	11
Document Jam	146
Document Wire Extension	2
DPOF Printing	68
Dual Access	23

E	
ECM (Error Correction Mode)	174
Entering Text	169
Error Messages	145
Extension Telephone	42
Extension Telephones	12
External Telephone	14, 42
External Telephone Answering Device (TAD)	13
F	
F/T (FAX/TEL) Mode	7
F/T (Fax/Tel) Ring Time	24
F/T Ring Time	42
Fax Detect	25
Fax Forwarding	47
Fax Mode	7, 27
Fax Redial	22
Fax Strage	47
Fax Tones and Handshake	174
Filter Core	90
Fine (Resolution)	21
Function Selection Table	170
G	
Glossary	175
Glossy Paper	166
Grey scale	163
H	
Help	ii
I	
iMac	137
Important Safety Instructions	161
Importing	126
Ink Cartridges	4, 158
Ink Management Key	104
Inserting Spaces	169
Install MFL-Pro	100
Installing Brother Drivers (for Machintosh [®] G3, G4 or iMac)	137
International Calls	36
Interrupting	39
J	
Job Cancel	39
Job Status	46
JOURNAL	32
Journal Period	33
L	
Legal Limitations	59
Loading Paper	3
M	
Macintosh [®] G3, G4 or iMac [™]	137
Maintenance	145, 157
Manual Dialing	7
Manual Mode	7
MEMORY FULL	145
Memory Full Message	53
MEMORY STATUS	32
Memory Storage	9
Menu Mode	iii
Multi-Function Link [®] Pro	76, 134
Multi-Line Connections	11
Multiple Resolution Transmission	39
Multi-Purpose Paper Cassette	103
Multi-purpose Sheet Feeder	2
Mute	16, 30
N	
NO FILE	145

NO RESPONSE/BUSY	146
NOT ASSIGNED	146

O

One Touch Dial (Changing)	20
One Touch Dial (Storing)	19
On-Line Documentation	101
On-Screen Programming	iii
Options Key for Copy	54
Options Key for PhotoCapture Centre ...	70
Options Key for Video Printing	62
Order Form	32
Orientation	107
Outgoing Message	14
Overseas Mode	36

P

PABX	11, 18
Packing and Shipping	155
Paper (Loading)	3
Paper Jam	147
Paper Size	106, 167
Paper Specifications	167
Paper Tab	105
Paper Thickness	107
Paper Type	58, 167
PaperPort	124
Pause	30
Photo (Resolution)	21
PhotoCapture Centre™	67, 136
PhotoCapture Centre™ Requirements ...	75
Polling (Receive)	44
Polling (Transmit)	46
Power Cord	8
Print a Report	33
Print Area	168
Print Media	164

Print Quality	153
Print Size	62
Printer Driver Settings	105
PRINTER JAM	146
Printer Operation Keys	104
Printer Platen	158
Printing Images	69
Product Description	163

Q

Quality/Colour Tab	108
QUICK-DIAL (list)	32

R

Real Time Transmission	23
Receive Mode	25
Reception into Memory	28
Reduction (Printing)	27
Remote Access Code	48
Remote Code (Changing)	43
Remote Commands	49
Remote Retrieval	48
Remote Setup	135
Reports	32
Reset Key	104
Resolution	21
Resolution (Multiple)	39
Ring Delay	24
Ring Volume	18

S

Safety Instructions	161
Scan Image	114
Scan Keys	113
Scan to E-mail	114
Scan to File	118
Scan to Word Processor	121

Scan/OCR	114
Scanning into PC	127
ScanSoft™ PaperPort®	124
Scroll	iii
Search	16, 30
Simultaneous Printing/Fax	104
Speaker Volume	18
Special characters	169
Specifications	163
Speed Dial	20
Speed Dial (Changing)	20
Standard (Resolution)	21
Station ID	6, 10
Storing Telephone number	19
SYSTEM SETUP	32

T

TAD	7
TEL. INDEX	32
TextBridge® OCR	124
Thumbnails	69
To change Remote Codes	43
Tone/Pulse	10
Trademarks	165
Transmission Verification (Xmit) Report	32
Transparencies	166
Troubleshooting	145
TWAIN COMPLIANT	127
TX Lock	40

U

USB Cable	90
User Defined Button	122

V

Vertical Black Lines	149
Video Capture	131

Video Printing	60
Video Printing (Black & White)	61
Video Printing (Brightness)	63, 66
Video Printing (Changing Default Settings)	63
Video Printing (Colour Adjustment)	66
Video Printing (Colour)	61
Video Printing (Setting Paper Type)	64
Video Printing (Setting Print Size)	65
Video Printing (Setting Quality)	65
Video Printing (Setting Video Type)	65
Video Type	62

W

WARMING UP	146
Windows® 2000 Professional	82
Windows® 95,98,98SE,2000 Professional or NT® WS 4.0	77
Word Processor	121

X

XMIT REPORT	32
-------------------	----

Change Answer ModePress **9 8***then for* **TAD**, press **1**.**Fax/Tel (F/T)**, press **2**.**Fax**, press **3**.**Exit Remote Operation**Press **9 0**.**Change Remote Access Code**

- 1** Press **Menu**, **1**, **8**, **3**.
- 2** Enter the 3-digit number. The * cannot be changed.
- 3** Press **Set**.
- 4** Press **Stop** to exit.

REMOTE CONTROL ACCESS CARD**Using Remote Access Code**

- 1** Dial your MFC phone number from a touch tone phone.
- 2** Enter your Remote Control Access Code (159*) after the beep.
- 3** Your machine signals the kinds of messages received:
 - 1 long beep — Fax message(s)**
 - No beeps — no messages**
- 4** After 2 short beeps, enter a command.
- 5** Press **9 0** to reset your machine when you finish.
- 6** Hang up.

4

1

Remote Commands

Change Fax Forwarding Setting

Press **9 5**

then to **Turn feature off** press **1**.

Enter Fax Forwarding press **2**.

Program Fax Forward Number press **4**.

Enter the new number of the remote fax machine where you want your fax message forwarded and then press **##**.

Press **9 6 1** after two short beeps, then enter the number of remote fax machine, and then **##** to retrieve Memory Status para recuperar la Lista de List.

Turn Fax Storage on press **6**.

Turn Fax Storage off press **7**.

2

Retrieve Fax

Press **9 6**

then to **Print a Memory Status List** press **1**,

then enter the number of remote fax machine, and then **##**. After the beep, hang up and wait.

Retrieve all faxes press **2**, then enter the number of remote fax machine, and then **##**. After the beep, hang up and wait.

Erase all fax messages press **3**.

Check the Receiving Status

Press **9 7 1**.

1 long beep — Fax message(s)

3 short beeps — no messages

3



EC Declaration of Conformity for Facsimile machines under R & TTE DIRECTIVE.

Manufacturer

Brother Industries, (johor) Sdn. Bhd.
No.6 Jalan Firma 1, kawasan Perindustrian
Tebrau, 81100 Johor Bahru, Johor Darul
Takzim, Malaysia
Telephone: 60-7-3533-331 (4 Lines)
Facsimile: 60-7-3533-332

Authorised Representative

Brother International Europe Ltd.,
Brother House, 1 Tame Street,
Audenshaw, Manchester, M34 5JE, UK.

Herewith declare that:

Products description : Brother Fax Machines
Type : Group 3 Ink Jet
Model Name : MFC-830 / MFC-840

Are in conformity with provisions of the R & TTE DIRECTIVE (99/5/EC)

Standards applied:

Harmonized : Safety : EN 60950 : up to Amd 11, 1997
: EMC : EN55022 / 1998 Class B
: MFC-830 EN55024
: MFC-840 EN50082-1 / 1997
(valid through 30 Jun. 2001)
EN55024
(effective from 1 July 2001)
: EN61000-3-2 /1995 + A2 / 1998
: EN61000-3-3 / 1995

Year in which CE marking was First affixed : 2000

brother®

This machine is approved for use in the country of purchase only, local Brother companies or their dealers will only support fax machines purchased in their own countries.

UK/IRE
LE3534004①
Printed in Malaysia