



This recycle mark indicates that the packaging conforms to the environmental protection legislation in Germany.

Esta marca de reciclaje indica que el empaquetado se ajusta a la legislación de protección ambiental en Alemania.

CASIO®

CASIO COMPUTER CO.,LTD.
6-2, Hon-machi 1-chome
Shibuya-ku, Tokyo 151-8543, Japan

MA9910-A (英) (西) Printed in China
CTK651-ES-1

P.

CTK-651

USER'S GUIDE GUÍA DEL USUARIO

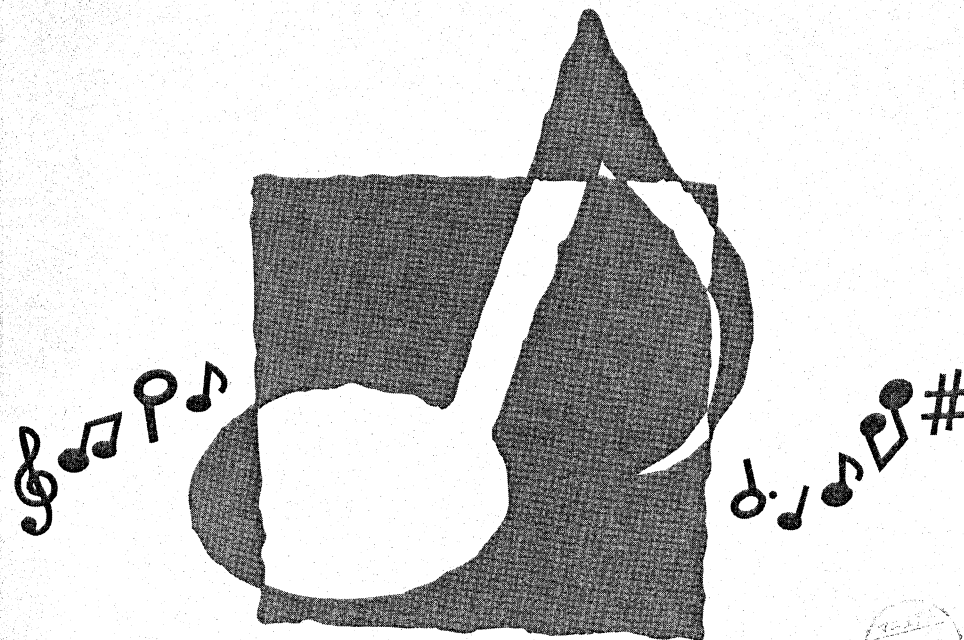

YAMAHA

CASIO®

P.
CTK651-ES-1

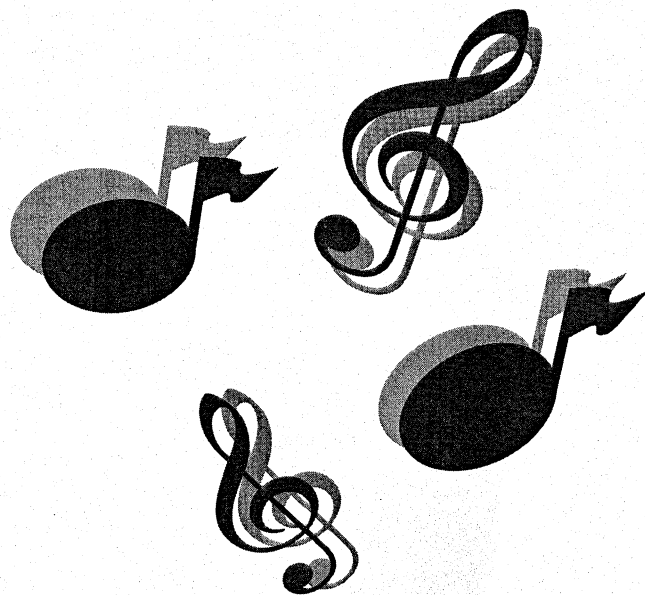
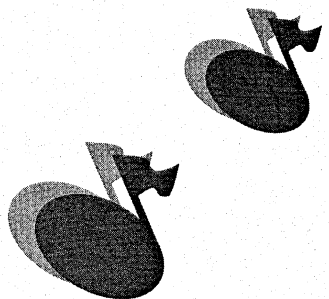

Welcome...

To the happy family of satisfied CASIO electronic musical instrument owners! To get the most out of the many features and functions of the keyboard, be sure to carefully read this manual and keep it on hand for future reference.

Important!

When using batteries, be sure to replace them or shift to one of the alternate power sources whenever you notice any of the following symptoms.

- Dim power supply indicator
- Instrument does not turn on
- Display that is flickering, dim, or difficult to read
- Abnormally low speaker/headphone volume
- Distortion of sound output
- Occasional interruption of sound when playing at high volumes
- Sudden power failure when playing at high volumes
- Flickering or dimming of the display when playing at high volume
- Continued sound output even after you release a key
- A totally different tone may sound
- Abnormal rhythm pattern and demo tune play
- Loss of power, sound distortion, or low volume when playing from a connected computer or MIDI device

GUIDELINES LAID DOWN BY FCC RULES FOR USE OF THE UNIT IN THE U.S.A. (not applicable to other areas).

NOTICE

This equipment has been tested and found to comply with the limits for a Class B digital device, pursuant to Part 15 of the FCC Rules. These limits are designed to provide reasonable protection against harmful interference in a residential installation. This equipment generates, uses and can radiate radio frequency energy and, if not installed and used in accordance with the instructions, may cause harmful interference to radio communications. However, there is no guarantee that interference will not occur in a particular installation. If this equipment does cause harmful interference to radio or television reception, which can be determined by turning the equipment off and on, the user is encouraged to try to correct the interference by one or more of the following measures:

- Reorient or relocate the receiving antenna.
- Increase the separation between the equipment and receiver.
- Connect the equipment into an outlet on a circuit different from that to which the receiver is connected.
- Consult the dealer or an experienced radio/TV technician for help.

FCC WARNING

Changes or modifications not expressly approved by the party responsible for compliance could void the user's authority to operate the equipment.



CASIO ELECTRONICS CO., LTD.
Unit 6, 1000
North Circular Road
London NW2 7JD, U.K.

This mark is valid in the EU countries only.
Please keep all information for future reference.

Introduction

Congratulations upon your selection of this CASIO musical instrument. This keyboard provides you with the following features and functions.

□ 200 tones

- An entire orchestra of 168 preset musical instrument sounds, synthesized sounds, drum sounds and more at your fingertips! You can even store up to 32 of sounds you create yourself for instant recall when you need them.

□ 100 rhythms

- 100 versatile rhythms help to add plenty of life to all your keyboard performances.

□ Auto Accompaniment

- Simply play a chord and the corresponding rhythm, bass and chord parts play automatically. One-touch Presets instantly recalls the most suitable tone and tempo settings to match the rhythm you are using.

□ Big, Information-packed Display

- A big built-in display shows chord names, tempo setting, keyboard information, staff notation of notes played, and more for full support of all your keyboard play. A built-in backlight keeps the display easy to read, even in total darkness.

□ Memory Function

- Record up to six parts in memory and their tone, volume, pan position, and other parameters for later playback. Realistic ensemble play can also be created using the Auto Accompaniment function.

□ Synthesizer Mode

- Edit built in sounds to produce your own original creations. Up to 32 of your own sounds can be stored in memory for recall just like the built-in tones.

□ General MIDI compatibility

- The General MIDI tones of this keyboard let you connect to a personal computer to enjoy "desktop music" capabilities. This keyboard can be used as a desktop music input device or sound source, and it's just the thing for playback of commercially available pre-recorded General MIDI music software.

□ Reverb Function

- A built-in reverb function lets you select from among studio, stage, or concert hall effects to suit just about any music you might want to play.

□ Mixer

- You can specify tone, volume, pan position, and other parameters for each built-in Auto Accompaniment part. You can also control the same parameters for each channel during MIDI input.

□ Registration Memory

- Keyboard setups can be stored in memory for later recall and instant settings whenever you need them. Up to 32 setups (4 setups x 8 banks) can be stored in registration memory.

Safety Precautions

Symbols

Various symbols are used in this operating manual and on the product itself to ensure that the product is used safely and correctly, and to prevent injury to the user and other persons as well as damage to property. Those symbols along with their meanings are shown below.

⚠ WARNING

This indication stipulates matters that have the risk of causing death or serious injury if the product is operated incorrectly while ignoring this indication.

⚠ CAUTION

This indication stipulates matters that have the risk of causing injury as well as matters for which there is the likelihood of occurrence of physical damage only if the product is operated incorrectly while ignoring this indication.

Symbol Examples



This triangle symbol (\triangle) means that the user should be careful. (The example at left indicates electrical shock caution.)



This circle with a line through it (\odot) means that the indicated action must not be performed. Indications within or nearby this symbol are specifically prohibited. (The example at left indicates that disassembly is prohibited.)



The black dot (\bullet) means that the indicated action must be performed. Indications within this symbol are actions that are specifically instructed to be performed. (The example at left indicates that the power plug must be unplugged from the electrical socket.)

⚠ WARNING

Please use caution regarding the handling of the AC adaptor.



- Do not use a voltage other than the indicated power supply voltage. Use of a voltage other than that indicated may cause fire or electrical shock.
- If the power cord should become damaged (exposed wires, disconnection, etc.), purchase a new AC adaptor. Use of a damaged power cord may cause fire or electrical shock.

- Do not cut or damage the power cord. Also do not place heavy objects on top of it or subject it to excessive heat. Damage to the power cord may cause fire or electrical shock. 
- Do not attempt to shape the power cord or subject it to excessive bending, twisting or pulling. This may cause fire or electrical shock.
- Please use the adaptor specified for this instrument. Use of another adaptor may cause fire, electrical shock, or malfunction.

Do not locate the instrument or its stand on an uneven or unstable surface.

- Locating the instrument or its stand on an uneven or unstable surface can cause it to fall, creating the danger of personal injury.

Do not place containers containing water or other liquids on the instrument.

- Do not place the following objects on the instrument. Placing such objects on the instrument may cause fire or electrical shock if they spill and get inside the instrument. 
 - Containers filled with water or other liquids (including vases, potted plants, cups, cosmetics and medicines) 
 - Small metal objects (including hairpins, sewing needles and coins)
 - Flammable objects

In the event a foreign object should happen to get inside the instrument, please take the following actions:

1. Turn power off.
2. Unplug the AC adaptor from the wall outlet. 
3. If there are any batteries loaded in the keyboard, remove them.
- Do not touch the batteries directly with your hands when removing them. They may be hot or battery fluid may be leaking from them.
4. Consult with the dealer where you purchased the keyboard or with an authorized CASIO service provider.

Do not disassemble or modify the instrument.

- Never attempt of take apart or modify the instrument, its accessories, or separately sold options. Doing so may cause fire, electrical shock or malfunction. Consult your dealer concerning all inspection, adjustment or repair of internal components. 

Do not use if there is an abnormality or malfunction.

- Do not use the instrument if there appear to be abnormalities such as the presence of smoke or abnormal odor. Also do not use the instrument if there appear to be malfunctions such as the power not coming on or sound not being produced. Use under such conditions may cause fire or electrical shock. In such cases, take the following actions immediately. Never attempt to repair the instrument yourself.



1. Turn power off.
2. Unplug the AC adaptor from the wall outlet.
3. If there are any batteries loaded in the keyboard, remove them.
- Do not touch the batteries directly with your hands when removing them. They may be hot or battery fluid may be leaking from them.
4. Consult with the dealer where you purchased the keyboard or with an authorized CASIO service provider.



When the instrument has been dropped:

- In the case the instrument has been dropped or damaged, take the following actions. Continued use may cause fire or electrical shock.



1. Turn power off.
2. Unplug the AC adaptor from the wall outlet.
3. If there are any batteries loaded in the keyboard, remove them.
- Do not touch the batteries directly with your hands when removing them. They may be hot or battery fluid may be leaking from them.
4. Consult with the dealer where you purchased the keyboard or with an authorized CASIO service provider.



Be careful of the bags around children.

- Never allow anyone to place the plastic bags of the instrument, its accessories, and its separately sold options over their heads. Doing so may cause suffocation. Particular caution is required in homes with small children.

CAUTION

AC Adaptor

- Do not locate the power cord in close proximity to heaters or other heating appliances. This may cause the cord to melt leading to possible fire or electrical shock.
- When unplugging the AC adaptor from an electrical outlet, always make sure to pull on the adaptor itself and not the cord. Pulling excessively on the cord may cause it to be damaged or break leading to possible fire or electrical shock.
- Do not touch the AC adaptor with wet hands when it is plugged in. This may cause electrical shock.
- When not using the instrument for an extended period such as when traveling, always make sure to unplug the AC adaptor from the electrical outlet for safety reasons.
- After use turn off the power switch of the instrument and unplug the AC adaptor from the electrical outlet.
- At least once a year, unplug the AC adaptor from the power outlet and clean the area around the prongs of the plug. Dust build up around the prongs can create the danger of fire.



Batteries

- Improper battery use may cause batteries to rupture and leak. This may cause injury, malfunction of the instrument or discoloration of furniture and other articles that come into contact with battery fluid. Take care to observe the following.
 - Install batteries so their polarity (+/-) matches that indicated on the instrument.
 - For safety and to prevent possible leakage of battery fluid, always make sure to remove batteries from the instrument when you do not plan to use it for a long time.
 - Always make sure that the batteries making up a set are all of the same type.
 - Never combine new batteries with old ones.
 - Never dispose of batteries by incinerating them. Never short or disassemble batteries, and do not expose them to excessive heat.
 - Replace dead batteries as soon as possible.
 - Never attempt to recharge batteries.

Transport

- When transporting the instrument, always make sure to unplug the AC adaptor from the electrical outlet and confirm that all other external connections have been disconnected. Only then should the instrument be transported. If the above is not done, the cord may be damaged leading to possible fire or electrical shock.



Care

- Whenever caring, make sure to first unplug the AC adaptor from the electrical outlet. Also remove the instrument's batteries if battery power is being used.



Location

- Never locate the instrument in areas subject to high humidity or heavy accumulation of dust. Doing so may cause fire or electrical shock.
- Never locate the instrument in areas subject to grease splatters or steam, such as in a kitchen or near a humidifier. Doing so may cause fire or electrical shock.



Do not place keyboard on lacquered furniture.

- The instrument's silicone rubber feet may eventually blacken or scar lacquered surfaces. Use felt cloth pads to insulate the feet or preferably use a CASIO musical instrument stand designed for your keyboard.

Do not place heavy objects on the instrument.

- Do not place heavy objects on the instrument. This may cause the instrument to tip over or break resulting in injury.

Volume

- Very high volume levels can damage hearing. Avoid using the instrument at very high volume settings for long periods. Consult with a physician immediately if you experience impaired hearing or ringing in the ears.

Liquid Crystal Display (LCD) Precautions

- Avoid subjecting the keyboard's LCD to strong impact, which can crack or break the LCD's glass creating the danger of personal injury.
- Should the LCD glass ever crack or break, do not allow the liquid inside the LCD to come into contact with your skin, which can cause inflammation and reddening.
 - *Should the LCD liquid get into your mouth, immediately wash out your mouth with water and then consult a physician.
 - *Should the LCD liquid get in your eyes or on your skin, immediately flush with water for at least 15 minutes and then consult a physician.

Do not get onto the instrument or stand.*

- Do not crawl on top of the instrument or its optional stand. Particular caution is required in homes having small children. This may cause the instrument or stand to tip over and break resulting in injury.

Optional Stand*

- Carefully assemble the stand following the assembly instructions that come with it. Securely tighten all bolts, nuts, and fasteners, and make sure that you mount the instrument correctly onto the stand. Incorrectly or insufficiently tightening screws, or incorrectly mounting the instrument onto the stand can cause the stand to tip over or the instrument to fall off the stand, possibly leading to injury.

* The stand is available as an option.

Care of your keyboard

Avoid heat, humidity or direct sunlight.

Do not overexpose the instrument to direct sunlight, or place it near an air conditioner, or in any extremely hot place.

Do not use near a TV or radio.

This instrument can cause video or audio interference with TV and radio reception. If this happens, move the instrument away from the TV or radio.

Do not use lacquer, thinner or similar chemicals for cleaning.

Clean the keyboard with a soft cloth dampened in a weak solution of water and a neutral detergent. Soak the cloth in the solution and squeeze until it is almost dry.

Avoid use in areas subjected to temperature extremes.

Extremely high or low temperature can cause figures on the LCD screen to become dim and difficult to read. This condition should correct itself when the keyboard is brought back to normal temperature.

NOTE

You may notice lines in the finish of the case of this keyboard. These lines are a result of the molding process used to shape the plastic of the case. They are not cracks or breaks in the plastic, and are no cause for concern.

Contents

Welcome	E-1
Introduction	E-2
Safety Precautions	E-3
Care of your keyboard	E-6
Contents	E-6
General Guide	E-8
About the display	E-10
Power Supply	E-11
Using batteries	E-11
Using the AC Adaptor	E-12
Auto Power Off.....	E-12
Memory Contents	E-12
Connections	E-13
Basic Operations	E-14
To play the keyboard.....	E-14
Selecting a Tone	E-14
Using Reverb	E-15
Using Pitch Bend	E-15
Using the Drum Pads.....	E-15
Auto Accompaniment	E-16
Selecting a Rhythm.....	E-16
Playing a Rhythm.....	E-16
Adjusting the Tempo	E-17
Using Auto Accompaniment	E-17
Using an Intro Pattern.....	E-19
Using a Fill-in Pattern	E-20
Using a Rhythm Variation	E-20

Using a Fill-in Pattern with a Variation Rhythm	E-20
Synchro Starting Accompaniment with Rhythm Play	E-20
Finishing with an Ending Pattern	E-20
Using One-touch Preset	E-21
Adjusting the Accompaniment Volume	E-21
Deleting an Auto-accompaniment Part	E-21

Mixer Function.....

What you can do with the Mixer	E-22
Using the Channel Edit Mode	E-22
Using the Parameter Edit Mode	E-23

Synthesizer Mode.....

Synthesizer Mode Functions	E-25
Creating a User Tone	E-27
Naming a User Tone and Storing It In Memory	E-29

Registration Memory.....

Registration Memory Features	E-31
To Save a Setup in Registration Memory ...	E-32
To Recall a Setup from Registration Memory	E-32

Memory Function.....

Tracks	E-33
Basic Memory operations	E-33
Using Real-time Recording	E-33
Touch Response Setting.....	E-34
Mixer Mode Settings	E-34
Playing Back From Memory	E-35
Recording Melody and Chords with Step Recording	E-36
Recording Multiple Tracks	E-38
Correcting Mistakes While Step Recording ...	E-40
Editing Memory Contents	E-41
Deleting Individual Data Items from Memory	E-43

Deleting All of the Data in a Specific Track	E-43
--	------

Keyboard Settings.....

Using Layer	E-44
Using Split.....	E-45
Using Layer and Split Together	E-45
Using Touch Response	E-46
Transposing the Keyboard.....	E-47
Tuning the Keyboard	E-47

MIDI.....

What is MIDI?	E-48
General MIDI	E-48
Changing MIDI Settings	E-50
Dumping Internal Data	E-52

Troubleshooting.....

Specifications.....

Appendix.....

Note Table	A-1
Drum Assignment List.....	A-2
Fingered Chord Chart	A-3

MIDI Implementation Chart

General Guide

• Key, button, and other names are indicated in the text of this manual using bold type.

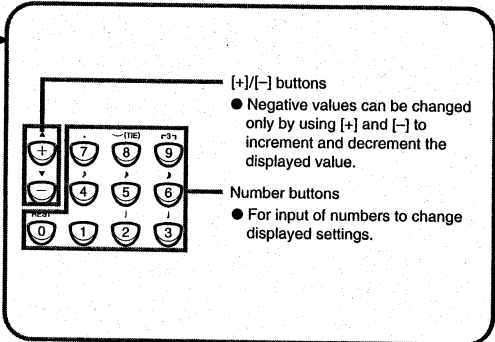
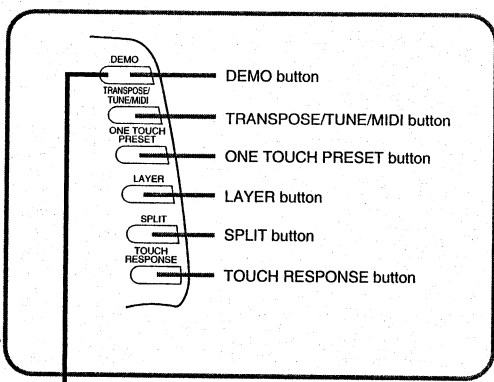
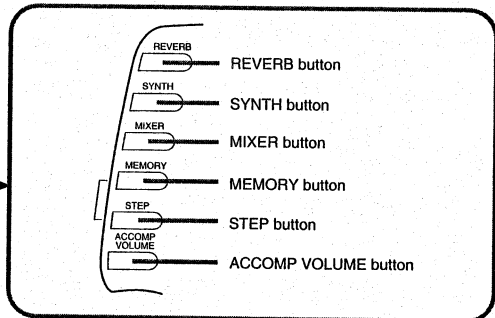
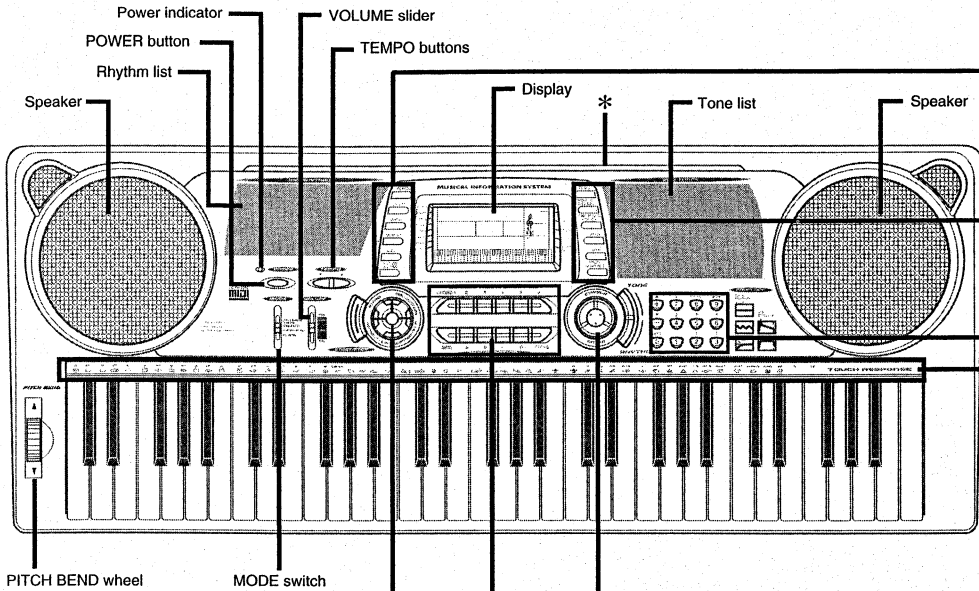

Playing a Demo Tune

Pressing the DEMO button starts demo tune play. There are two demo tunes, which continuously play in sequence. To stop demo tune play, press either the DEMO button or the START/STOP button.

NOTES

- Pressing the [+]/[-] button skips to the next demo tune.
- You can select a tone for the keyboard (page E-14) before starting demo tune play, and then use that tone to play along with the demo tune.
- MIDI, Layer, and Split are disabled while a demo tune is playing.

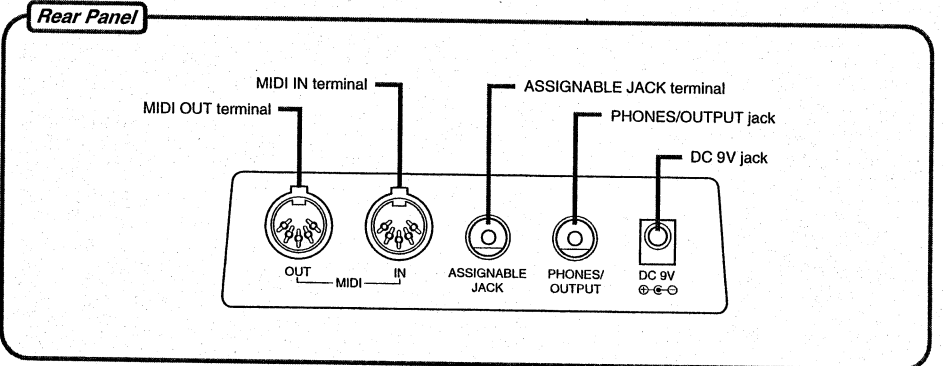
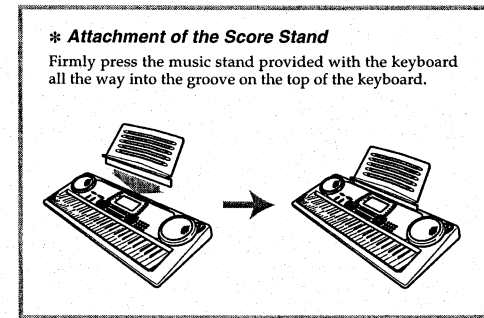
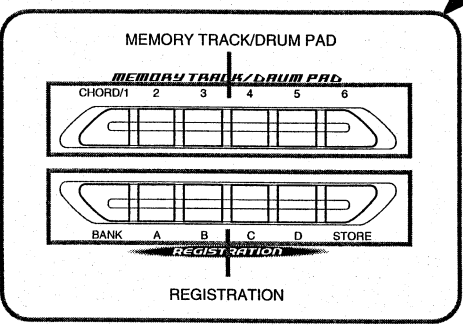
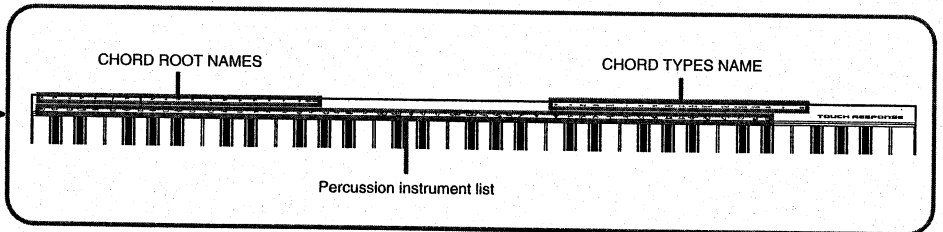
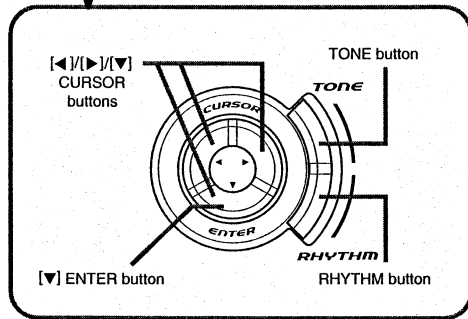
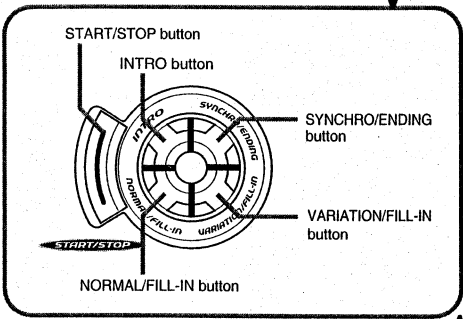

About the display

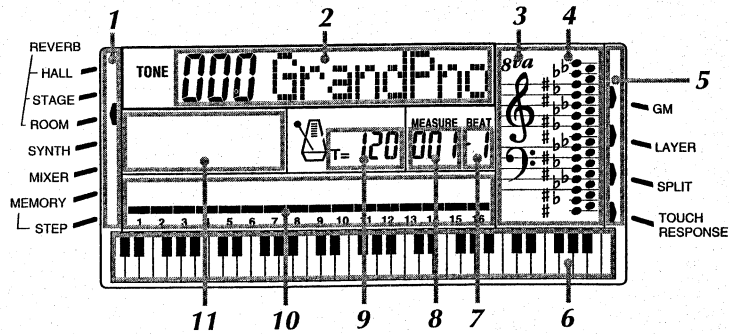

1. A bar appears to indicate the function (reverb, synthesizer, mixer, memory) currently in use. In this example, the display indicates that ROOM setting of the Reverb function is being used.
2. Tone number/Tone name
The tone number/ tone name area is also used to indicate the rhythm number and rhythm name, and to indicate various functions in the Synthesizer Mode, Mixer Mode, Registration Mode, and Memory Mode.
3. Octave Symbol
Appears when the note produced by the keyboard is one octave higher than the note indicated on the staff.
4. Notes you play on the keyboard, notes being played back from memory, chord forms, and received MIDI data are shown in the staff on the display.
5. A bar appears to indicate the function (General MIDI Mode, Layer, Split, Touch Response) currently in use.
6. This display shows the note played on the keyboard, notes being played back from memory, chord forms, and received MIDI data.
7. The beat number is indicated while a rhythm, Auto-accompaniment, or Memory Mode is being used.
The number of measures/beat area is also used to indicate the mixer channel, and Synthesizer Mode's parameters.
8. The measure number is indicated while a rhythm, Auto-accompaniment, or Memory Mode is being used.
9. The number of beats per minute are indicated while a rhythm, Auto-accompaniment, or Memory Mode is being used.
The tempo area is also used to indicate the mixer setting value, and the Memory function's clock.
10. Level Meter
The velocity of each channel is indicated as one of three levels. This display also shows the Mixer functions on/off status.
11. The name of the chord being played is shown on the display while Auto Accompaniment is being used.

NOTES

- Display examples shown in this User's Guide are intended for illustrative purposes only. The actual text and values that appear on the display may differ from the examples shown in this User's Guide.
- Backlight brightness may appear somewhat unstable immediately after the keyboard is turned on. This does not indicate malfunction, and brightness will stabilize after a few seconds.

The back light that illuminates the LCD screen can lose intensity after very long. When this happens, contact your original retailer or CASIO service provider to have the backlight replaced. You will be charged for this replacement.

Power Supply

This keyboard can be powered by current from a standard household wall outlet (using the specified AC adaptor) or by batteries. Always make sure you turn the keyboard off whenever you are not using it.

Using batteries

Always make sure you turn off the keyboard before loading or replacing batteries.

To load batteries

1. Remove the battery compartment cover.

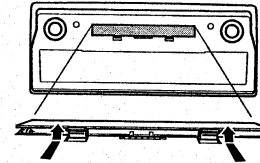

2. Load six D-size batteries into the battery compartment.

- Make sure that the positive (+) and negative (-) ends are facing correctly.

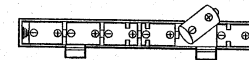

3. Insert the tabs on the battery compartment cover into the holes provided and close the cover.

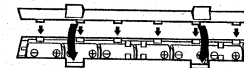

The keyboard may not function correctly if you load or replace batteries with power turned on. If this happens, turning the keyboard off and then back on again should return functions back to normal.

Important Battery Information

- The following shows the approximate battery life.
 - Standard battery life: Approximately 4 hours (UM-1/R20)
 The above value is standard battery life at normal temperature, with the keyboard volume at a medium setting. Temperature extremes or playing at very loud volume settings can shorten battery life.
- Any of the following symptoms indicate low battery power. Replace batteries as soon as possible whenever any of the following occurs.
 - Dim power supply indicator
 - Instrument does not turn on
 - Display that is flickering, dim, or difficult to read
 - Abnormally low speaker/headphone volume
 - Distortion of sound output
 - Occasional interruption of sound when playing at high volumes
 - Sudden power failure when playing at high volumes
 - Flickering or dimming of the display when playing at high volume
 - Continued sound output even after you release a key
 - A totally different tone may sound
 - Abnormal rhythm pattern and demo tune play
 - Loss of power, sound distortion, or low volume when playing from a connected computer or MIDI device

IMPORTANT!

Improper handling of batteries can cause them to burst and leak, which creates the danger of personal injury or damage due to contact with battery acid. Be sure to note the following important precautions.

- Always make sure that the positive (+) and negative (-) poles are facing correctly as indicated near the battery compartment.
- To avoid damage caused by leaking batteries, be sure to remove batteries from the keyboard whenever you leave it unattended for long periods (such as when leaving on a trip).
- Never mix batteries of different types.
- Never mix old batteries with new ones.
- Never discard batteries by incinerating them, do not allow their poles to be shorted (connected to each other), never take batteries apart, and do not expose batteries to direct heat.
- Replace batteries as soon as possible after any sign they are getting weak.
- Never attempt to recharge batteries.

Using the AC Adaptor

Make sure that you use only the AC adaptor specified for this keyboard.

Specified AC Adaptor: AD-5

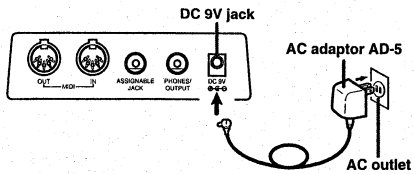

Also note the following important warnings and precautions when using the AC adaptor.

WARNING!

- Take care to avoid any damage to or breakage of the power cord. Never place any heavy objects on the power cord or expose it to direct heat. Doing so creates the danger of power cord damage, fire, and electrical shock.
- Use only the specified AC adaptor. Use of another type of adaptor creates the danger of fire and electrical shock.

CAUTION!

- For safety sake, be sure to unplug the AC adaptor from the wall outlet whenever leaving the keyboard unattended for a long time (such as when leaving on a trip).
- Always turn off the keyboard and unplug the AC adaptor from the wall outlet when you are not using the keyboard.

IMPORTANT!

- Make sure that the keyboard is turned off before connecting or disconnecting the AC adaptor.
- Using the AC adaptor for a long time can cause it to become warm to the touch. This is normal and does not indicate malfunction.

Auto Power Off

When you are using battery power, keyboard power turns off automatically whenever you leave it on without performing any operation for about 6 minutes. When this happens, press the POWER button to turn power back on.

NOTE

Auto Power Off is disabled (it does not function) when you are using the AC adaptor to power the keyboard.

To disable Auto Power Off

Hold down the TONE button while turning on the keyboard to disable Auto Power Off.

- When Auto Power Off is disabled, the keyboard does not turn off automatically no matter how long it is left with no operation being performed.
- Auto Power Off is automatically enabled whenever you turn on keyboard power.

Settings

Tone, rhythm, and other "main keyboard settings" in effect when you turn off the keyboard manually by pressing POWER or when Auto Power Off turns off power are still in effect the next time you turn power back on.

Main Keyboard Settings

Tone number, layer, split, split point, touch response, reverb, rhythm number, tempo, Mixer Mode settings (channel, on/off/solo, program change number, volume, pan pot), General MIDI Mode on/off, basic channel, MIDI in chord judge on/off, accomp MIDI out on/off, navigate track, pitch bend range, assignable jack setting, accompaniment volume, user area tones (Synthesizer Mode).

Memory Contents

In addition to the above settings, data stored in the Registration Mode and Memory Mode is also retained when keyboard power is turned off.

Electrical Power

The settings and memory data described above are retained as long as the keyboard is being supplied with electrical power. Unplugging the AC adaptor when batteries are not loaded or when loaded batteries are dead cuts off the keyboard's electrical power supply. This causes all settings to be initialized to their factory defaults and clears all data stored in memory.

Power Requirements

Note the following precautions whenever you want to ensure that current keyboard settings and memory contents are not lost.

- Make sure the keyboard is being supplied power through the AC adaptor before replacing its batteries.
- Before unplugging the AC adaptor, make sure that fresh batteries are loaded in the keyboard.
- Make sure that keyboard power is turned off before replacing batteries or unplugging the AC adaptor.

Remember that you can also dump the memory contents of this keyboard to another MIDI device using the procedure described under "Dumping Internal Data" on page E-52.

Resetting the Keyboard

Use the following reset procedure to return the keyboard to its factory default settings (the settings it had when you purchased it).

IMPORTANT!

The following procedure deletes all data stored in the Synthesizer Mode and the Memory Mode. Make sure you no longer need the data before performing the following procedure.

To reset the keyboard

1. Remove all batteries from the keyboard and disconnect the AC adaptor.
2. Hold down the POWER button for about 20 seconds.

Connections

Phones/Output Terminal

Before connecting phones or other external equipment, be sure to first turn down the volume settings of the keyboard and the connected equipment. You can then adjust volume to the desired level after connections are complete.

[Rear Panel]

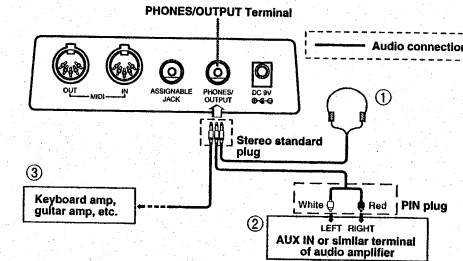

Connecting Phones (Figure ①)

Connecting phones cuts off output from the keyboard's built-in speakers, so you can play even late at night without disturbing anyone.

Audio Equipment (Figure ②)

Connect the keyboard to a audio equipment using a commercially available connecting cord with a standard plug on one end and two PIN plugs on the other end. Note that the standard plug you connect to the keyboard must be a stereo plug, otherwise you will be able to output only one of stereo channels. In this configuration, you normally set the input selector of the audio equipment to the terminal (usually marked AUX IN or something similar) where the cord from the keyboard is connected. See the user documentation that comes with your audio equipment for full details.

Musical Instrument Amplifier (Figure ③)

Use a commercially available connecting cord to connect the keyboard to a musical instrument amplifier.

NOTE

Be sure to use a connecting cord that has a stereo standard plug on the end you connect to the keyboard, and a connector that provides dual channel (left and right) input to the amplifier to which you are connecting. The wrong type of connector at either end can cause one of the stereo channels to be lost.

When connected to a musical instrument amplifier, set the volume of the keyboard to a relatively low level and make output volume adjustments using the amplifier's controls.

Connection Example

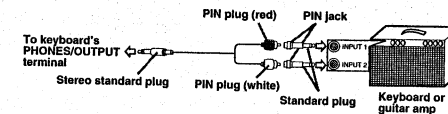

NOTE

You can also connect the keyboard to a computer or sequencer. See "MIDI" on page E-48 for details.

Assignable jack Terminal

You can connect an optional sustain pedal (SP-2 or SP-10) to the ASSIGNABLE JACK terminal to enable the capabilities described below.

For details on how to select the pedal function you want, see "ASSIGNABLE JACK TERMINAL" on page E-51.

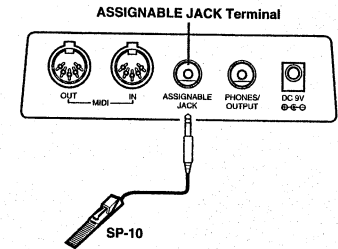

Sustain Pedal

- With piano tones, depressing the pedal causes notes to linger, much like a piano's damper pedal.
- With organ tones, depressing the pedal causes notes to continue to sound until the pedal is released.

Sostenuto Pedal

- As with the sustain pedal function described above, depressing the sostenuto pedal causes notes to be sustained.
- This difference between a sostenuto pedal and sustain pedal is the timing. With a sostenuto pedal, you press the keys and then depress the pedal before you release the keys. Only the notes that are sounding when the pedal is depressed are sustained.

Soft Pedal

Depressing the pedal softens the sound of the notes being played.

Rhythm Start/Stop Pedal

In this case, the pedal performs the same functions as the START/STOP button.

Accessories and Options

Use only the accessories and options specified for this keyboard. Use of non-authorized items creates the danger of fire, electrical shock, and personal injury.

Basic Operations

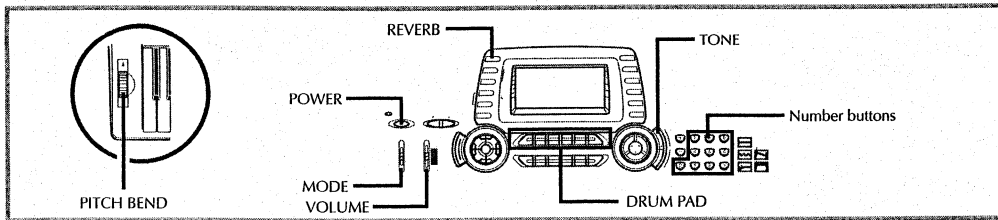

This section provides information on performing basic keyboard operations.

To play the keyboard

1. Press the **POWER** button to turn the keyboard on.
2. Set the **MODE** switch to **NORMAL**.
3. Use the **VOLUME** slider to set the volume to a relatively low level.
4. Play something on the keyboard.

Selecting a Tone

This keyboard comes with 200 built-in tones. Use the following procedure to select the tone you want to use.

To select a tone

1. Find the tone you want to use in the keyboard's **tone list** and note its tone number.
2. Press the **TONE** button.



3. Use the **number buttons** to input the three digit tone number for the tone you want to select.
Example: To select "032 ACOUSTIC BASS", input 0, 3 and then 2.



NOTES

- Always input all three digits for the tone number, including leading zeros (if any). If you input one or two digits and stop, the display will automatically clear your input after a few seconds.
- You can also increment the displayed tone number by pressing [+] and decrement it by pressing [-].
- When one of the drum sets is selected (tone numbers 160 through 167), each keyboard key is assigned a different percussion sound. See page A-2 for details.
- The names of tone numbers 128 through 199 are not marked on the keyboard console. Consult the following table when selecting a tone in this range.

Names of tone numbers 128 through 199

No.	Tone list	No.	Tone list	No.	Tone list
128	SYNTH-PAD 1	144	ECHO P.ORGAN	160	DRUM SET 1
129	SYNTH-PAD 2	145	ROTARY ORGAN	161	DRUM SET 2
130	OCTAVE PIANO	146	CHORUSED EP	162	DRUM SET 3
131	OCTAVE HARPSI	147	STRINGS GT	163	DRUM SET 4
132	12 STR GUITAR 1	148	PAD ENS 1	164	DRUM SET 5
133	OCT JAZZ GUITAR	149	PAD ENS 2	165	DRUM SET 6
134	OCTAVE SAX	150	SEQUENCE 1	166	DRUM SET 7
135	TOUCH BASS*	151	SEQUENCE 2	167	DRUM SET 8
136	STRINGS PIANO*	152	SYNTH-PAD 3	168	
137	E.PIANO STRINGS*	153	SYNTH-PAD 4	169	See page E-26
138	STEREO PIANO	154	SYNTH-PAD 5	199	
139	12 STR GUITAR 2	155	SYNTH-PAD 6		
140	BRASS FALL	156	SYNTH-PAD 7		
141	BASS SLIDE	157	SYNTH-PAD 8		
142	FEEDBACK GT	158	REVERSE ECHO		
143	PIANO → STRINGS	159	FAST TREMOLO		

- * What you hear differs according to how strongly you press the keyboard.

Polyphony

The term polyphony refers to the maximum number of notes you can play at the same time. The keyboard has 24-note polyphony, which includes the notes you play as well as the rhythms and auto-accompaniment patterns that are played by the keyboard. This means that when a rhythm or auto-accompaniment pattern is being played by the keyboard, the number of notes (polyphony) available for keyboard play is reduced. Also note that some of the tones offer only 12-note polyphony.

- When rhythm or auto accompaniment is playing, the number of sounds simultaneously played is reduced.

Digital Sampling

A number of the tones that are available with this keyboard have been recorded and processed using a technique called digital sampling. To ensure a high level of tonal quality, samples are taken in the low, mid, and high ranges and then combined to provide you with sounds that are amazingly close to the originals. You may notice very slight differences in volume or sound quality for some tones when you play them at different positions on the keyboard. This is an unavoidable result of multiple sampling, and it is not a sign of malfunction.

Using Reverb

Reverb creates ambience effects by causing the sound to linger and reverberate.

To use reverb

Use the **REVERB** button to select the type of reverb you want to use. Each press of **REVERB** selects cycles through the available settings. The current setting is indicated by the bar on the keyboard's display.

HALL

This setting creates a concert hall effect.

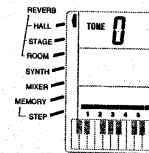

STAGE

With this setting, you get the acoustics of a small club.

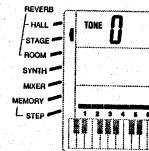

ROOM

This setting adds the acoustics of a studio to the sound.

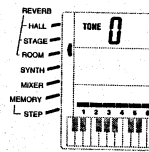

REVERB OFF

Reverb is off when there is no bar on the display indicating a reverb effect.

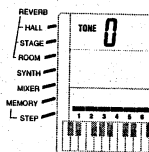

Using Pitch Bend

Pitch bend lets you "bend" a note by altering its pitch. It helps to create realistic effects for saxophone and other reed instrument tones.

To use pitch bend

1. Select a tone.
Example: "065 ALTO SAX"
2. While holding down a keyboard key with your right hand, rotate the **PITCH BEND** wheel up or down.
Example: Upward rotation of the **PITCH BEND** wheel.
 - The pitch of the **ALTO SAX** you are playing slides smoothly upwards.
 - Releasing the **PITCH BEND** wheel returns the note to its original pitch.

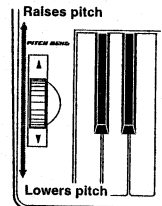

NOTES

- The most realistic effect is obtained with saxophone and electric guitar tones if you rotate the **PITCH BEND** wheel at about the same instant you press the keyboard key.
- See page E-51 for details on controlling the amount of pitch change produced with the **PITCH BEND** wheel.

Using the Drum Pads

This keyboard has a total of six drum pads that can be used to play drum sounds independent of the keyboard keys.

To play a drum pad

Simply tap on a drum pad to play the percussion sound currently assigned to it.

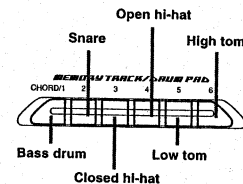

Drum Pad Sounds

This keyboard features a total of **eight different drum sets**.* Selecting a drum set automatically assigns the sounds of the set to the drum pads. To change the drum set setting, use the **Mixer** to change the tone (**drum set**)* assigned to Channel 10. See page E-22 for details on using the **Mixer**.

*Tone numbers: 160 to 167

NOTE

The drum set also is changed by changing the rhythm number, by playing back data stored in memory, and by receipt of MIDI program change data.

Auto Accompaniment

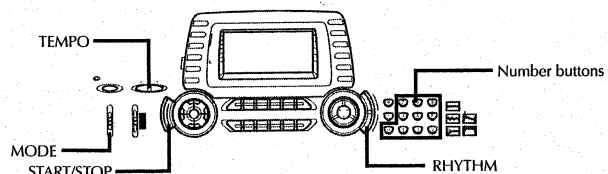

This keyboard automatically plays bass and chord parts in accordance with the chords you finger. The bass and chord parts are played using sounds and tones that are automatically selected to select the rhythm you are using. All of this means that you get full, realistic accompaniments for the melody notes you play with your right hand, creating the mood of an one-person ensemble.

Selecting a Rhythm

This keyboard provides you with 100 exciting rhythms that you can select using the following procedure.

To select a rhythm

1. Find the rhythm you want to use in the keyboard's **rhythm list** and note its rhythm number.
2. Press the **RHYTHM** button.

Number and Name of selected rhythm



Appears when RHYTHM button is pressed

3. Use the **number buttons** to input the two digit rhythm number for the rhythm you want to select.
Example: To select "31 ROCK", input 3 and then 1.



NOTE
You can also increment the displayed rhythm number by pressing [+], and decrement it by pressing [-].

Playing a Rhythm

Use the following procedure to start and stop rhythm play.

To play a rhythm

1. Set the **MODE** switch to **NORMAL**.
2. Press the **START/STOP** button to start play of the currently selected rhythm.
3. To stop rhythm play, press the **START/STOP** button again.

NOTE
All of the keyboard keys are melody keys while the **MODE** switch is set to **NORMAL**.

Adjusting the Tempo

You can adjust the tempo of rhythm play within a range of 40 to 255 beats per minute. The tempo setting is used for Auto Accompaniment chord play, and Memory operations.

To adjust the tempo

Press one of the **TEMPO** buttons (▲ or ▼).
▲ : Increments displayed value (increases tempo)
▼ : Decrements displayed value (decreases tempo)



- The flashing tempo value automatically clears from the display if you do not input anything within about five seconds.

NOTES

- While the tempo setting is flashing, you can use either the number buttons or [+], and [-] buttons to change the tempo setting. When using the number buttons, be sure to input all three digits, including leading zeros if necessary. To specify a value of 90, for example, you would input: 090.
- Pressing both **TEMPO** buttons (▲ and ▼) at the same time resets the tempo to the default value of the currently selected rhythm.

Using Auto Accompaniment

The following procedure describes how to use the keyboard's Auto Accompaniment feature. Before starting, you should first select the rhythm you want to use and set the tempo of the rhythm to the value you want.

To use Auto Accompaniment

1. Set the **MODE** switch to **CASIO CHORD**, **FINGERED**, or **FULL RANGE CHORD**.
2. Press the **START/STOP** button to start play of the currently selected rhythm.
3. Play a chord.
 - The actual procedure you should use to play a chord depends on the current **MODE** switch position. Refer to the following pages for details on chord play.

CASIO CHORD Page E-18
FINGERED Page E-18
FULL RANGE CHORD Page E-19

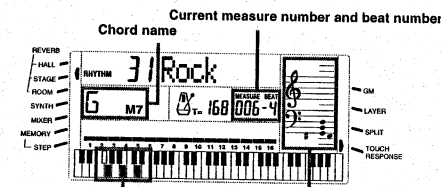

Basic fingering of current chord
(May be different from chord actually being played on the keyboard.)

4. To stop Auto Accompaniment play, press the **START/STOP** button again.

CASIO CHORD

This method of chord play makes it possible for anyone to easily play chords, regardless of previous musical knowledge and experience. The following describes the CASIO CHORD "Accompaniment keyboard" and "Melody keyboard", and tells you how to play CASIO CHORDS.

CASIO CHORD Accompaniment Keyboard and Melody Keyboard

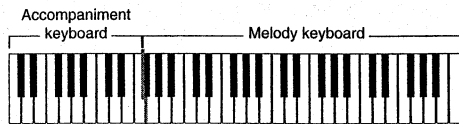

NOTE

The accompaniment keyboard can be used for playing chords only. No sound will be produced if you try playing single melody notes on the accompaniment keyboard.

Chord Types

CASIO CHORD accompaniment lets you play four types of chords with minimal fingering.

Chord Types	Example
Major chords Major chord names are marked above the keys of the accompaniment keyboard. Note that the chord produced when you press an accompaniment keyboard does not change octave, regardless of which key you use to play it.	C Major (C)
Minor chords (m) To play a minor chord, keep the major chord key depressed and press any other accompaniment keyboard key located to the right of the major chord key.	C minor (Cm)
Seventh chords (7) To play a seventh chord, keep the major chord key depressed and press any other two accompaniment keyboard keys located to the right of the major chord key.	C seventh (C7)
Minor seventh chords (m7) To play a minor seventh chord, keep the major chord key depressed and press any other three accompaniment keyboard keys located to the right of the major chord key.	C minor seventh (Cm7)

NOTE

It makes no difference whether you press black or white keys to the right of a major chord key when playing minor and seventh chords.

FINGERED

FINGERED provides you with a total of 15 different chord types. The following describes the FINGERED "Accompaniment keyboard" and "Melody keyboard", and tells you how to play a C-root chord using FINGERED.

FINGERED Accompaniment Keyboard and Melody Keyboard

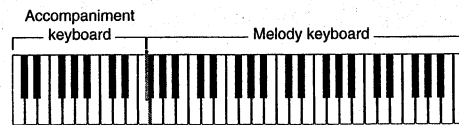

NOTE

The accompaniment keyboard can be used for playing chords only. No sound will be produced if you try playing single melody notes on the accompaniment keyboard.

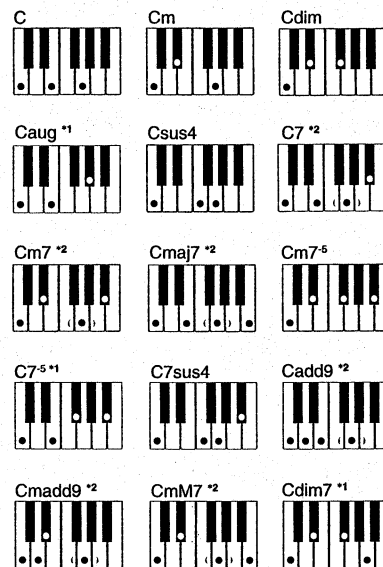

See the "Fingered Chord Chart" on page A-3 for details on playing chords with other roots.

- *1: Inverted fingerings cannot be used. The lowest note is the root.
- *2: The same chord can be played without pressing the 5th G.

NOTES

- Except for the chords specified in note*1 above, inverted fingerings (i.e. playing E-G-C or G-C-E instead of C-E-G) will produce the same chords as the standard fingering.
- Except for the exception specified in note*2 above, all of the keys that make up a chord must be pressed. Failure to press even a single key will not play the desired FINGERED chord.

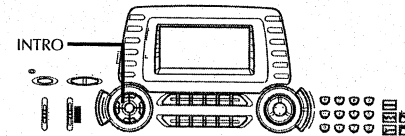

FULL RANGE CHORD

This accompaniment method provides a total of 38 different chord types: the 15 chord types available with FINGERED plus 23 additional types. The keyboard interprets any input of three or more keys that matches a FULL RANGE CHORD pattern to be a chord. Any other input (that is not a FULL RANGE CHORD pattern) is interpreted as melody play. Because of this, there is no need for a separate accompaniment keyboard, so the entire keyboard, from end to end, functions as a melody keyboard that can be used for both melody and chords.

FULL RANGE CHORD Accompaniment Keyboard and Melody Keyboard

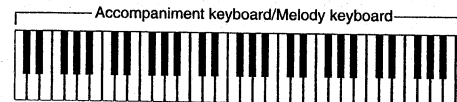

Chords Recognized by This Keyboard

The following table identifies patterns that are recognized as chords by FULL RANGE CHORD.

Pattern Type	Number of Variations
FINGERED	The 15 chord patterns shown under FINGERED on page E-18. See the FINGERED CHORD Chart on page A-3 for details on playing chords with other roots.
Standard Fingerings	23 standard chord fingerings. The following are examples of the 23 chords available with C as the bass note. C ₆ • C _{m6} • C ₆₉ $\frac{C^{\#}}{C} \cdot \frac{D}{C} \cdot \frac{E}{C} \cdot \frac{F}{C} \cdot \frac{G}{C} \cdot \frac{A^{\flat}}{C} \cdot \frac{B^{\flat}}{C}$ $\frac{B}{C} \cdot \frac{C^{\flat}m}{C} \cdot \frac{Dm}{C} \cdot \frac{Fm}{C} \cdot \frac{Gm}{C} \cdot \frac{Am}{C} \cdot \frac{B^{\flat}m}{C}$ $\frac{Dm7^{\flat 5}}{C} \cdot \frac{A^{\flat 7}}{C} \cdot \frac{F7}{C} \cdot \frac{Fm7}{C} \cdot \frac{Gm7}{C} \cdot \frac{A^{\flat add9}}{C}$

Example: To play the chord C major.

Any of the fingerings shown in the illustration below will produce C major.

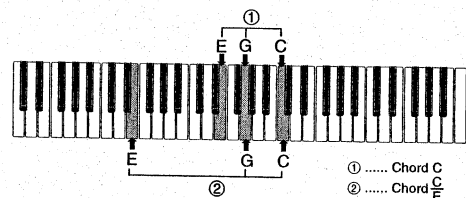

- ① Chord C
- ② Chord C_E

NOTES

- As with the FINGERED mode (page E-18), you can play the notes that form a chord in any combination (①).
- When the lowest notes of a chord are separated from its neighboring note by six or more semitones, the lowest note becomes the bass note (②).

< Music Example >

Tone: 016
Rhythm: 04
Tempo: 070



Using an Intro Pattern

This keyboard lets you insert a short intro into a rhythm pattern to make startup smoother and more natural.

The following procedure describes how to use the Intro feature. Before starting, you should first select the rhythm you want to use, and set the tempo.

To insert an intro

Press the **INTRO** button to start the selected rhythm with an intro pattern.

- With the above setup, the intro pattern is played and the auto accompaniment with intro pattern starts as soon as you play chords on the accompaniment keyboard.

NOTE

The standard rhythm pattern starts to play after the intro pattern is complete.

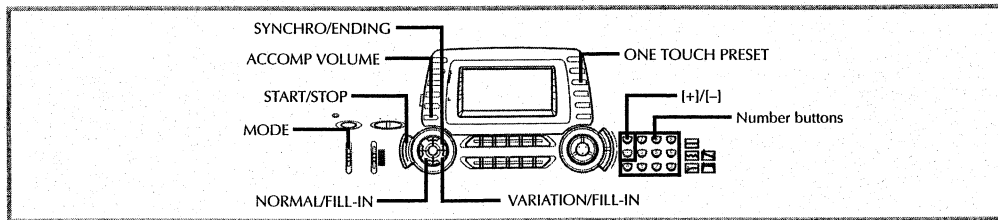

Using a Fill-in Pattern

Fill-in patterns let you momentarily change the rhythm pattern to add some interesting variation to your performances.

The following procedure describes how to use the Fill-in feature.

To insert a fill-in

1. Press the **START/STOP** button to start rhythm play.
2. Press the **NORMAL/FILL-IN** button to insert a fill-in pattern for the rhythm you are using.

NOTE

The fill-in pattern does not play if you press the **NORMAL/FILL-IN** button while an intro pattern is playing.

Using a Rhythm Variation

In addition to the standard rhythm pattern, you can also switch to a secondary "variation" rhythm pattern for a bit of variety.

To insert the variation rhythm pattern

1. Press the **START/STOP** button to start rhythm play.
2. Press the **VARIATION/FILL-IN** button to switch to the variation pattern for the rhythm you are using.

NOTE

To switch back to the standard rhythm pattern, press the **NORMAL/FILL-IN** button.

Using a Fill-in Pattern with a Variation Rhythm

You can also insert a fill-in pattern while a variation rhythm pattern is playing.

To insert a fill-in into a rhythm variation

While a variation rhythm pattern is playing, press the **VARIATION/FILL-IN** button to insert a fill-in pattern for the variation rhythm you are using.

Synchro Starting Accompaniment with Rhythm Play

You can set up the keyboard to start rhythm play at the same time you play the accompaniment on the keyboard.

The following procedure describes how to use synchro start. Before starting, you should first select the rhythm you want to use, set the tempo, and use the **MODE** switch to select the chord play method you want to use (**NORMAL**, **CASIO CHORD**, **FINGERED**, **FULL RANGE CHORD**).

To use synchro start

1. Press the **SYNCHRO/ENDING** button to put the keyboard into synchro start standby.



2. Play a chord and the rhythm pattern starts to play automatically.

NOTES

- If the **MODE** switch is set to **NORMAL**, only the rhythm plays (without a chord) when you play on the accompaniment keyboard.
- If you press the **INTRO** button before playing anything on the keyboard, the rhythm starts automatically with an intro pattern when you play something on the accompaniment keyboard.
- To cancel synchro start standby, press the **SYNCHRO/ENDING** button one more time.

Finishing with an Ending Pattern

You can end your performances with an ending pattern that brings the rhythm pattern you are using to a natural-sounding conclusion. The following procedure describes how to insert an ending pattern. Note that the actual ending pattern played depends on the rhythm pattern you are using.

To finish with an ending pattern

While the rhythm is playing, press the **SYNCHRO/ENDING** button. This causes the ending pattern to play which brings rhythm accompaniment to an end.

- The timing when the ending pattern starts depends on when you press the **SYNCHRO/ENDING** button. If you press the button before the second beat of the current measure, the ending pattern starts playing immediately. Pressing the button at any point in the measure after the second beat results in the ending pattern playing from the beginning of the following measure.

Using One-touch Preset

One-touch preset automatically makes the settings listed below in accordance with the rhythm pattern you are using.

- Keyboard tone
- Tempo

To use one-touch preset

1. Select the rhythm you want to use.
2. Use the **MODE** switch to select the accompaniment mode you want to use.
3. Press the **ONE TOUCH PRESET** button.
 - This automatically makes the one-touch preset settings in accordance with the rhythm you selected.
4. Start rhythm and Auto Accompaniment, and play something on the keyboard.
 - Accompaniment is played using the one-touch preset settings.

Adjusting the Accompaniment Volume

You can adjust the volume of the accompaniment parts as a value in the range of 000 (minimum) to 127.

1. Press the **ACCOMP VOLUME** button.

Current accompaniment volume setting

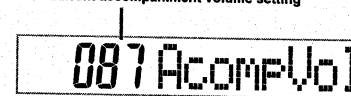

2. Use the **number buttons** or the **[+]/[-]** buttons to change the current volume setting value.

Example: 110

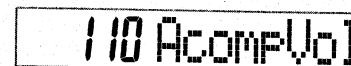

NOTES

- The current accompaniment volume value that appears in Step 1 automatically clears from the display if you do not input anything within about five seconds.
- Any channel balance settings you make with the Mixer are maintained when you change the accompaniment volume setting.
- Pressing **[+]** and **[-]** buttons at the same time automatically sets an accompaniment volume of 87.

Deleting an Auto-accompaniment Part

The auto-accompaniment patterns of this keyboard are made up of four parts: Chord 1, Chord 2, Bass, and rhythm. You can use the Mixer (page E-22) to delete any of the parts that you don't want to sound during accompaniment.

NOTE

With some rhythms, an auto-accompaniment part may contain all rests (nothing is played).

Mixer Function

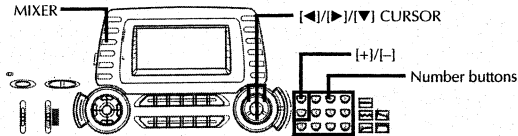

What you can do with the Mixer

This keyboard lets you play multiple different musical instrument parts at the same time during auto-accompaniment play, memory playback, receipt of data through the MIDI terminal, etc. The Mixer assigns each part to a separate channel (1 through 16) and lets you control the channel on/off, volume, and pan pot parameters of each channel.

Channel Assignments

The following shows the parts that are assigned to each of the 16 channels.

Channel Number	Part
Channel 1	Main tone
Channel 2	Layered tone
Channel 3	Split tone
Channel 4	Layered/split tone
Channel 5	No sound*
Channel 6	No sound*
Channel 7	Auto Accompaniment chord part 1
Channel 8	Auto Accompaniment chord part 2
Channel 9	Auto Accompaniment bass part
Channel 10	Auto Accompaniment rhythm part, drum pad
Channel 11	Memory track 1
Channel 12	Memory track 2
Channel 13	Memory track 3
Channel 14	Memory track 4
Channel 15	Memory track 5
Channel 16	Memory track 6

* Channels 5 and 6 produce sounds only when they receive MIDI signals.

See page E-44 and E-45 for information on layered, split, and layered/split tones.

See page E-33 for information on the memory.

NOTES

- Normally, keyboard play is assigned to Channel 1, while drum pads are assigned to Channel 10. When Auto Accompaniment is being used, each part of the accompaniment is assigned to Channels 7 through 10.
- When this keyboard is being used as the sound source for an externally connected computer or other MIDI device, all 16 channels are assigned musical instrument parts. In this case, Channel 10 is reserved for drum parts only. The notes played over the channel selected by steps 1 and 2 under "To make channel Edit Mode Settings" in the right column of this page are shown on the displayed keyboard and staff.

Using the Channel Edit Mode

The Channel Edit Mode can be used to change the status setting (on, off, solo) of a channel, to delete a specific part, or to play a specific part by itself.

To make Channel Edit Mode Settings

- Press the MIXER button.
 - This enters the Channel Edit Mode.

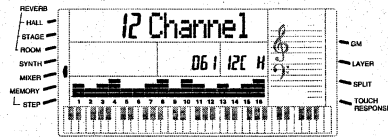

- Use the [+]/[-] buttons to select a channel.

Example: To select Channel 2.

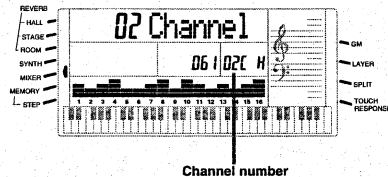

- Press [▶] to display the on, off, and solo selection screen.

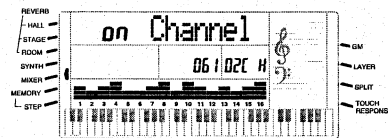

- Use the [+]/[-] buttons to select on, off, or solo.

Example: To turn the channel off.

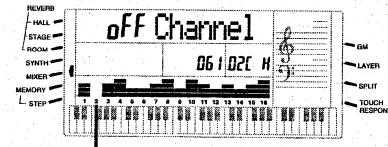

Bottom bar disappears when off

- Press the [◀] to return to the channel selection screen.
- Press the MIXER button to exit the Channel Edit Mode.

NOTE

The MIDI data display shows only the data for the channels selected with the Mixer.

About Channel Edit Mode settings

The following describes in detail what happens with each of the available Channel Edit Mode settings (on, off, SoL).

On (on)

This setting turns on the currently selected channel, which is indicated by a bar appearing at the bottom of the level meter for that channel. This is also the default setting for all channels when the keyboard is turned on.

Off (off)

This setting turns off the currently selected channel, which is indicated by the absence of the bar at the bottom of the level meter for that channel.

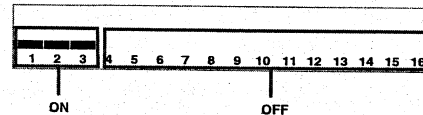

Solo (SoL)

Selecting this option turns on the currently selected channel and turns off all the other channels, which is indicated by a bar only at the bottom of the level meter for the channel that is turned on.

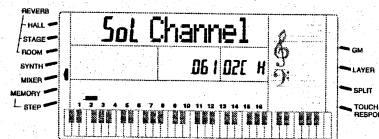

Using the Parameter Edit Mode

In the Parameter Edit Mode, you can change the settings of six different parameters (including tone, volume, and pan pot) for the channel you selected in the Channel Edit Mode.

To change parameters

- Use the Channel Edit Mode to select the channel whose parameters you want to change.

Example: Select Channel 3.

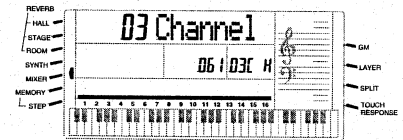

- Use [▼] to enter the Parameter Edit Mode.

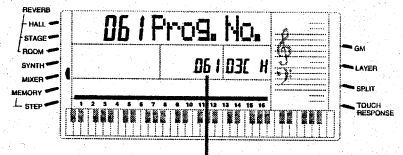

The program change number is also shown here.

- Use [◀] and [▶] to select the parameter whose setting you want to change.

Example: Select volume setting by displaying "Volume".

 - Each press of [◀] or [▶] cycles through the parameters.

Indicates channel volume of 127

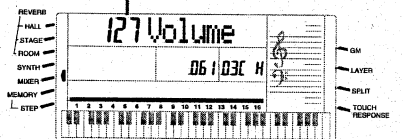

- Use the number buttons or [+]/[-] to change the parameter setting.

Example: Change the setting to "060".

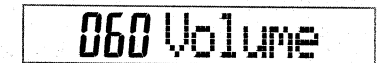

- Pressing the MIXER button exits the parameter edit mode.
- Pressing [▼] returns to the channel selection screen.

How parameters work

The following are the parameters whose settings can be changed in the Parameter Edit Mode.

■ Program Change Number (000 to 199)

This parameter controls the tone assigned to the channel.

06 Prog. No.

■ NOTES ■

- The tones assigned to Channels 7, 8, and 9 cannot be changed.
- Only tone numbers 160 (DRUM SET 1) through 167 (DRUM SET 8) can be selected for Channel 10.

■ Volume (000 to 127)

This is the parameter that controls the volume of the selected channel.

127 Volume

■ Pan Pot (000 to 127)

This parameter controls the pan pot, which is the center point of the left and right stereo channels. Setting 64 specifies center, a value less than 64 moves the point left, and a value greater than 64 moves it right.

064 Pan

■ Fine Tune (-50 to +50)

This parameter controls the fine tuning of the selected channel's pitch in cent units.

00 FineTune

■ Coarse Tune (-12 to +12)

This parameter controls the coarse tuning of the selected channel's pitch in semitone units.

00 C. Tune

■ Expression (000 to 127)

This parameter controls the volume of the selected channel. Though this parameter is identical to the volume parameter, it provides greater control over channel volume for desktop music applications.

127 Express

■ NOTE ■

Changing Mixer settings causes the corresponding MIDI messages to be output from the MIDI terminal.

Synthesizer Mode

The Synthesizer Mode of this keyboard provides the tools for creating your own original tones. Simply select one of the built-in tones and change its parameters to create your own original sound. You can even store your sounds in memory and select it using the same procedure as that used to select a preset tone.

Synthesizer Mode Functions

The following describes how to use each of the functions available in the Synthesizer Mode.

Synthesizer Mode Parameters

The preset tones that are built into this keyboard consist of a number of parameters. To create a user tone, you first recall a General MIDI tone (000 to 127) or a synthesized tone (128 to 159) and then change its parameters to change it to your own tone. Note that drum set tones (160 through 167) cannot be used as the basis of a user tone.

The illustration below shows the parameters that make up the preset tones and what each parameter does. As can be seen in the illustration, these parameters can be divided into four groups, each of which is described in detail below.

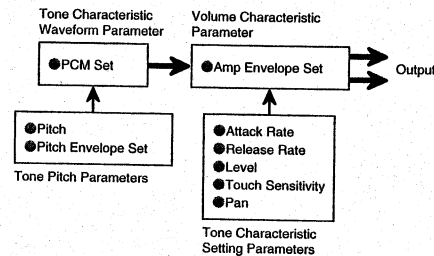

(1) Tone Characteristic Waveform Parameter

■ PCM Set

This parameter determines the characteristic of a tone by switching its digitally sampled waveform. You can select a piano, guitar, synthesizer, or any other of a variety of digitally sampled waveforms.

(2) Volume Characteristic Parameter

■ Amp Envelope Set

This set gives you a choice of a variety of different volume envelopes: slow attack when a key is pressed strongly, quick attack when a key is pressed, continued sound while a key is depressed, etc.

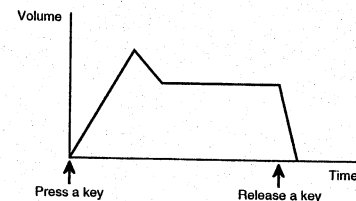

⊗ Gradual attack, followed by a lingering tone. ⊗

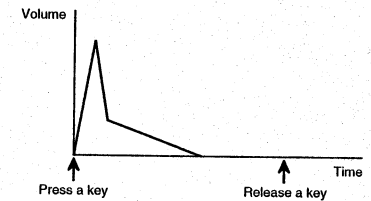

⊗ Sudden attack, followed by a gradual decay. ⊗

■ NOTE ■

Amp envelope set values in the range of 000 to 048 are for volume envelopes for a decaying note, while values in the range of 049 to 137 are for volume envelopes that sustain the note.

(3) Tone Pitch Parameters

■ Pitch

This parameter controls the overall pitch of the tone.

■ Pitch Envelope Set

This parameter provides a variety of pitch envelopes from which you can choose.

■ NOTE ■

A value of 00 specifies no change, a value from 01 to 19 changes the vibrato, and a value of 20 to 49 changes a parameter other than the vibrato.

(4) Tone Characteristic Setting Parameters

■ Attack Rate

This parameter lets you set the speed of the attack (the period from the point when you press a key to the point that the tone reaches its maximum volume). Use this parameter to make fine adjustments to the tone characteristics of the amp envelope you are using.

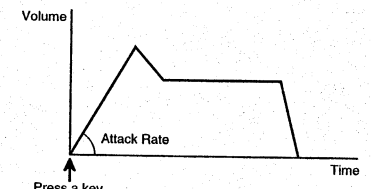

⊗ Tone with slow attack ⊗

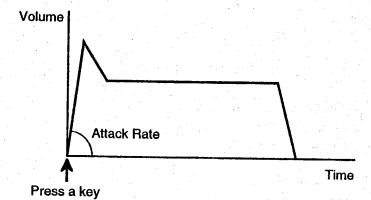

⊗ Tone with quick attack ⊗

■ NOTE ■

The attack becomes slower as the attack rate approaches 001 and faster as it approaches 127.

Release Rate

This parameter controls the speed of a tone's release (the period from the point when you release a key to the point that the tone stops sounding). Use this parameter to make fine adjustments to the tone characteristics of the amp envelope you are using.

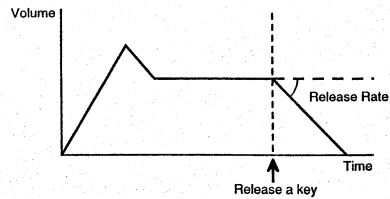

● Tone with slow release ●

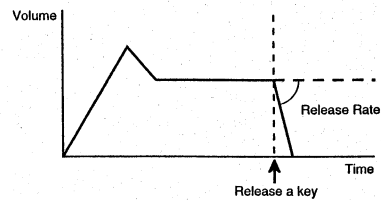

● Tone with quick release ●

NOTE

The release becomes slower as the release rate approaches 001 and faster as it approaches 127.

Level

This parameter controls the overall volume of the tone.

Touch Sensitivity

This parameter controls changes in the volume of the tone in accordance with the pressure applied to the keyboard keys. You can specify more volume for stronger pressure and less volume or a lighter pressure, or you can specify the same volume regardless of how much pressure is applied to the keys.

Pan

This parameter controls the stereo center point when using the keyboard's built-in speakers and when otherwise producing stereo output.

1DCO* and 2DCO Tones

"DCO" stands for the minimum unit of sound output for this keyboard. Some of the built-in tones are simple tones (1DCO), and some are layered tones (2DCO). Whenever you select a 2DCO tone as the basis for creating a user tone, remember that you must change the parameters of both of the tones (DCO1 and DCO2) that make up the layered 2DCO tone.

* DCO = Digital Controlled Oscillator

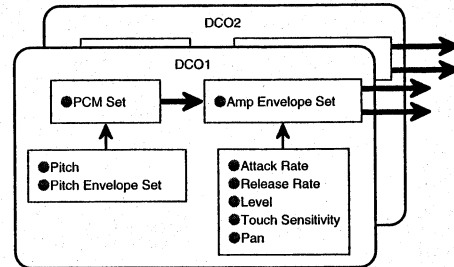

Saving User Tones

The group of tone numbers from 168 through 199 (USER01 through USER32) is called the "user area" because they are reserved for storage of user tones. After you recall a preset tone and change its parameters to create your own user tone, you can store it in the user area for later recall. You can recall your tones using the same procedure that you use when selecting a preset tone.

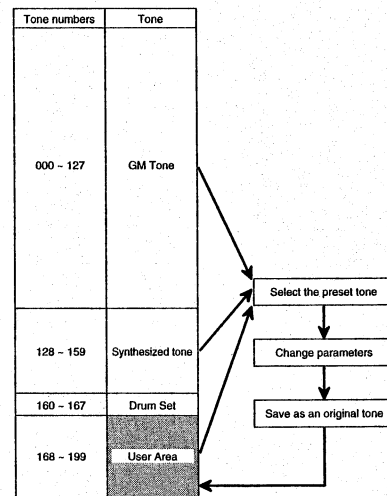

NOTES

- The keyboard is shipped from the factory with the same tones as the synthesized tone set (128 to 159) assigned to the user area.
- Note that creating a user tone does not change the preset tone. It creates a new version of the preset for storage in the user area.
- You cannot use a drum set tone (160 to 167) as the basis of a user tone.

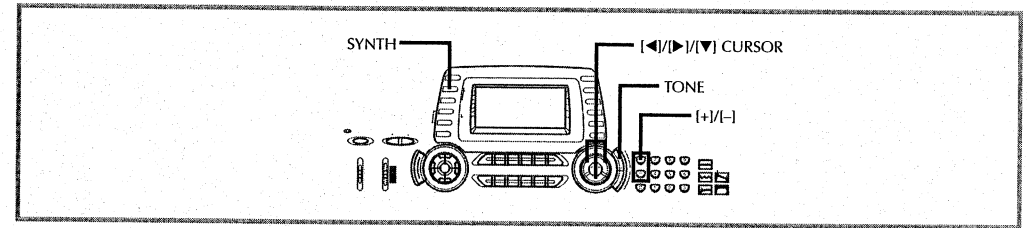

Creating a User Tone

Use the following procedure to select a preset tone and change its parameters to create a user tone.

- First, select the preset tone you want to use as a basis for your user tone.

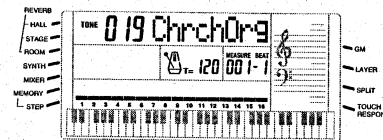

- Press the **SYNTH** button.

- This enters the Synthesizer Mode with the first parameter (PCM Set) recalled on the display. The display also shows whether the tone you selected is a DCO1 or DCO2 tone.

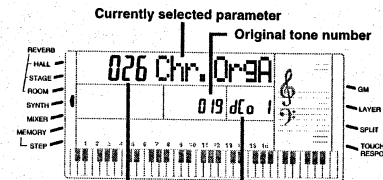

Parameter setting value Currently selected DCO (Displayed only when 2DCO tone is selected)

- Use [◀] and [▶] to display the parameter whose setting you want to change.

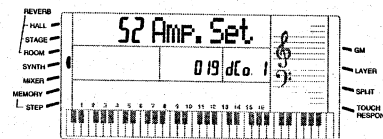

- Each press of [◀] or [▶] changes to the next parameter. See "Parameters and Their Settings" on page E-28 for information on setting range for each parameter.

- Use [+] and [-] to change the setting of the currently selected parameter.
 - You can also use the number buttons to input a value to change a parameter setting. See "Parameters and Their Settings" on page E-28 for information on setting range for each parameter.

- If the preset tone you selected in step 1 is a 2DCO tone, press [▼] to call up the DCO2 parameters.

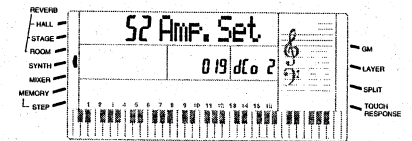

- Repeat steps 3 and 4 to set the DCO2 parameters.
 - Press [▼] again to return to the DCO1 parameters.

- After you are finished editing the sound, press the **SYNTH** button twice or press the **TONE** button once to exit the Synthesizer Mode.

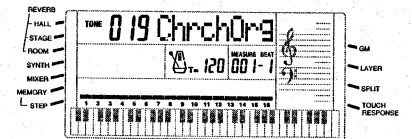

NOTE

Exiting the Synthesizer Mode in step 7 above causes the selected tone to return to its original built-in sound. See "Naming a User Tone and Storing It in Memory" on page E-29 for details on saving user tone data to memory so it is not deleted.

Parameters and Their Settings

The following describes the function and provides the setting range of each parameter.

■ PCM Set

This parameter switches the digitally sampled waveform. It can be set in a range of 0 to 179.

026 Chr. OrgA

■ Amp Envelope Set

This parameter controls tone characteristics. It can be set in a range of 0 to 127.

052 Amp. Set

■ Attack Rate

This parameter controls the speed of the attack. The greater the value, the quicker the attack. This parameter can be set in a range of 1 to 127.

127 Atk Rate

■ Release Rate

This parameter controls the speed of a tone's release. The greater the value, the quicker the release. This parameter can be set in a range of 1 to 127.

012 Rel. Rate

■ Pitch Envelope Set

This parameter controls the pitch of a tone. It can be set in a range of 0 to 49.

00 PitchSet

■ Pitch

This parameter controls the overall pitch of the tone. A greater positive value increases the pitch from standard, while a negative value lowers the pitch. A setting of zero sets the pitch to the standard setting for the selected tone. This parameter can be set in a range of -64 to +63.

00 Pitch

■ Level

This parameter controls the overall volume of the tone. The greater the value, the greater the volume. Setting a level of zero means that the tone does not sound at all. This parameter can be set in a range of 0 to 127.

096 Level

■ Touch Sensitivity

This parameter controls changes in the volume of the tone in accordance with the pressure applied to the keyboard keys. A greater positive value increases the volume of the output as pressure increases, while a negative value decreases volume with increased keyboard pressure. A setting of zero specifies no change in output volume in accordance with keyboard pressure. This parameter can be set in a range of -64 to +63.

32 TchSense

■ Pan

This parameter controls the stereo center point when using the keyboard's built in speakers. A greater positive value moves the center point further to the right, while a negative value moves it to the left. This parameter can be set in a range of -64 to +63. The Synthesizer Mode pan pot value is based on the pan pot value set in the Mixer's Parameter Edit Mode (page E-23) as the center position (0). Changing the setting to a positive value moves the center point to the right, while a negative value moves the center point to the left.

00 Pan

User Tone Creation Hints

The following hints provide helpful advice on making user tone creation a bit quicker and easier.

Use a preset tone that is similar to the one you are trying to create. Whenever you already have a rough idea of the tone you are trying to create, it is always a good idea to start with a preset tone that is similar. If you want to use a layered tone, start out with a 2DCO tone.

Determine the most important parameter.

The PCM Set and Amp Envelope Set parameters are the major factors that determine the overall personality of a tone. Start out with these two parameters to get the general sound you want, and then use the other parameters to add the finishing touches.

Experiment with various different settings.

There are no real rules about what a tone should sound like. Let your imagination run free and experiment with different combinations. You may be surprised at what you can achieve.

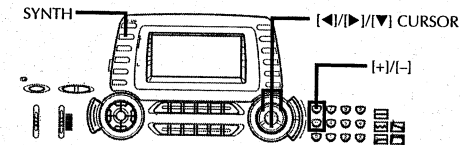

DATA EXAMPLE

Tone Name		Base tone number	
Pno + Str		051	
No.	Parameter	Range of Value	DCO1 DCO2
1	PCM Set	0 - 179	000 062
2	Amp Envelope Set	0 - 127	000 065
3	Attack Rate	1 - 127	127 005
4	Release Rate	1 - 127	010 005
5	Pitch Envelope Set	0 - 49	00 37
6	Pitch	-64 - 0 - 63	-16 00
7	Level	0 - 127	103 104
8	Touch Sense	-64 - 0 - 63	63 -64
9	Pan	-64 - 0 - 63	00 00

◆ Press keys hard/soft.

Tone Name		Base tone number	
Ambulance		080	
No.	Parameter	Range of Value	DCO1 DCO2
1	PCM Set	0 - 179	097 098
2	Amp Envelope Set	0 - 127	021 000
3	Attack Rate	1 - 127	004 003
4	Release Rate	1 - 127	001 010
5	Pitch Envelope Set	0 - 49	47 47
6	Pitch	-64 - 0 - 63	63 -64
7	Level	0 - 127	088 088
8	Touch Sense	-64 - 0 - 63	44 44
9	Pan	-64 - 0 - 63	-64 63

◆ Hold down keys.

Naming a User Tone and Storing It In Memory

The following procedure shows how to assign a name to a user tone and store the tone in memory. Once a tone is stored, you can call it up just as you do with a preset tone.

To name a user tone and store it in memory

1. Select a preset tone to use as the basis for the user tone, press the SYNTN button to enter the Synthesizer Mode, and make the parameter setting you want.

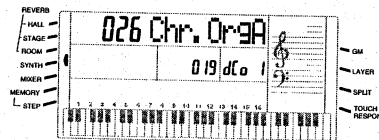

2. After making parameter settings to create the user tone, press the SYNTN button.
 - This causes the message "Save?" to appear on the display.

Save?

- To abort the save operation without saving anything, press [▶], which causes the message "Cancel?" to appear on the display. Press [▼].
- To interrupt the user tone creation procedure, press [▶] twice, which causes the message "Delete?" to appear on the display. Press [▼] to delete the original tone and exit the Synthesizer Mode.

3. When you are ready to save your user tone, press [▼] to display the destination user area tone number screen.

168 User 01

4. Use [+] and [-] to change the user area tone number on the display until the one where you want to store the tone is shown.
 - You can select any tone number from 168 to 199.

169 User 02

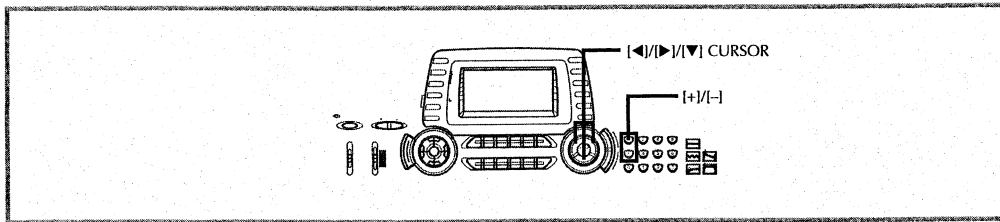

5. If you want to assign a name to the user tone, press [▶].

- This causes the first character of the tone name to flash, which indicates that you can input letters.



- If you do not want to assign a name, skip steps 5 through 7.

6. Use [+] and [-] buttons to select the first character of the name.



A	B	C	D	E	F	G	H	I	J
K	L	M	N	O	P	Q	R	S	T
U	V	W	X	Y	Z	[¥]	^
_	`	a	b	c	d	e	f	g	h
i	j	k	l	m	n	o	p	q	r
s	t	u	v	w	x	y	z	{	
}	→	←		!	”	#	\$	%	&
'	()	*	+	,	-	.	/	0
1	2	3	4	5	6	7	8	9	:
;	<	=	>	?	@				

7. Press [▶] to move to the next character. Repeat steps 5 and 6 to input the rest of the characters of the name.

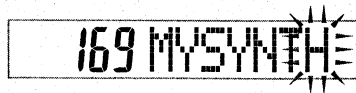

8. Press [▼] to save the user tone.

- The user tone is stored under the user area tone number you selected above, and the keyboard exits the Synthesizer Mode.
- Using [◀] in place of [▶] in step 7 returns to the tone storage selection screen in step 4. At this time you can change the user area tone number, which causes the name of the tone to change back to its preset name from any user name you assigned to it.
- Layer, split, Auto Accompaniment, demo tune play, and MIDI functions are all disabled in the Synthesizer Mode.



- To abort the save operation at any time, press the SYNTH button or the TONE button to exit the Synthesizer Mode. Pressing the SYNTH button again (before selecting another tone) returns to the Synthesizer Mode with all of your parameter settings still in place.

Registration Memory

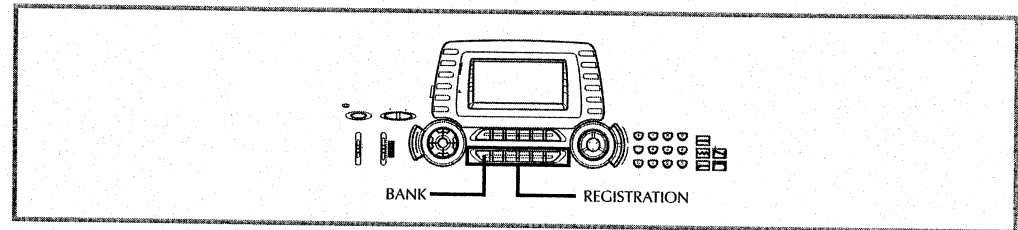

Registration Memory Features

Registration memory lets you store up to 32 (4 sets x 8 banks) keyboard setups for instant recall whenever you need them. The following is a list of settings that are saved in registration memory.

Registration Memory Settings

- Tone
- Rhythm
- Tempo
- Split on/off
- Split point
- Layer on/off
- Mixer settings (Channels 1~4)
- Keyboard channel on/off (Channels 1~10)
- Reverb settings
- Touch Response settings
- Assignable jack setting
- Transpose
- Tuning
- Pitch Bend range
- Accompaniment volume setting

NOTE

Registration memory functions are disabled while you are using the Synthesizer, Memory or demo tune function.

Initial Settings

BANK 0/2/4/6

	TO NE	RHYTHM
A	GRAND PIANO	8 BEAT BALLAD 1
B	OCTAVE PIANO	NEW ORLNS R&R
C	GRAND PIANO + VIBRAPHONE	SWING 2
D	GRAND PIANO + WARM PAD	WALTZ

BANK 1/3/5/7

	TO NE	RHYTHM
A	ROCK ORGAN + CALLIOPE	CLUB POP
B	OCTAVE SAX	50'S R&B BALLAD
C	FIFTH LEAD	TECHNO 1
D	NYLON STR GT	BOSSA NOVA 2

Setup Names

Set ups are stored into registration memory by assigning them names. Each setup name consists of a bank number from 0 to 7, followed by a letter from A to D. The 32 setup names range from 0A through 7D as shown below.

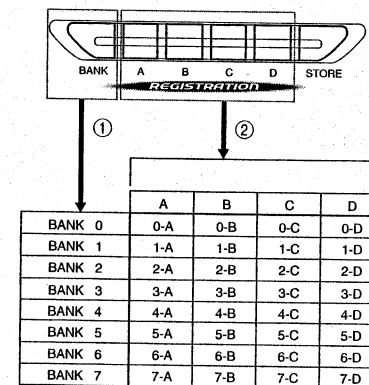

- Use the BANK button to select the bank. Each press of BANK cycles through the bank numbers from 0 to 7.
- Use the REGISTRATION buttons to specify the letter part of the setup name.

NOTES

- Whenever you save a setup and assign it a setup name, any setup data previously assigned to that name is replaced with the new data.
- You can use the keyboard's MIDI capabilities to save your setup data to a computer or other external storage device. See "Dumping Internal Data" on page E-52 for details.

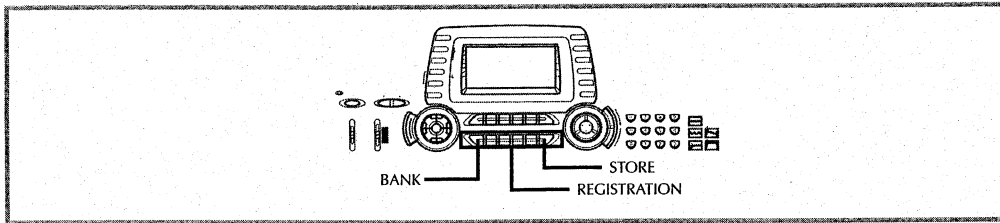

To Save a Setup in Registration Memory

1. Select a tone and rhythm, and otherwise set up the keyboard the way you want it.
 - See "Registration Memory Settings" on page E-31 for details on what data is stored in the registration memory.
2. Use the **BANK button** to select the bank you want.
 - If you do not perform any operation for about five seconds after pressing the BANK button, the display returns to the contents in step 1, above.

- Bank 0 selected.

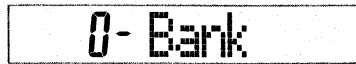

- Bank 1 selected.

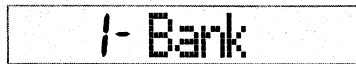

3. While holding down the **STORE button**, press a **REGISTRATION button**.

- The following display appears when you press the B button.

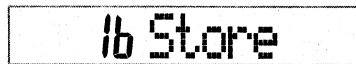

4. Release the **STORE** and **REGISTRATION button**.

NOTE
The setup is saved as soon as you press a REGISTRATION button in step 3, above.

To Recall a Setup from Registration Memory

1. Use the **BANK button** to select the bank.
 - If you do not perform any operation for about five seconds after pressing the BANK button, the keyboard automatically clears the registration memory recall screen.



2. Press the **REGISTRATION button** to input the letter part of the setup name.



- The setup name along with the message "Recall" appear on the display for about five seconds.

NOTE
If you press a REGISTRATION button without using the BANK button to select a bank first, the last bank number selected is used.

Memory Function

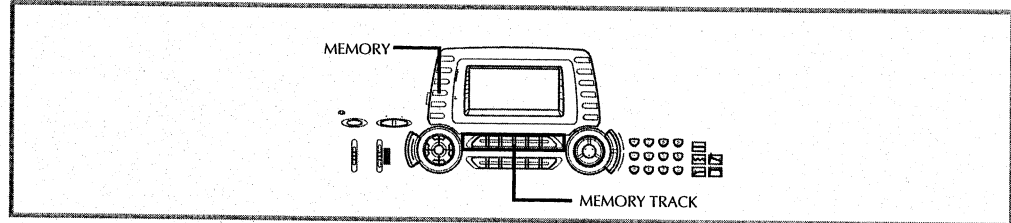

This keyboard lets you record up to two separate songs in memory for later playback. There are two methods you can use to record a song: real-time recording where you record the notes as you play them on the keyboard, and step recording where you input chords and notes one-by-one.

NOTE
Layer and split cannot be used while standing by for recording or while recording is being performed in the Memory Mode. Also, layer and split are automatically turned off whenever the keyboard goes into record standby or starts recording.

Tracks

Keyboard memory records and plays back much like a standard tape recorder. There are a total of six tracks, each of which can be recorded separately. Besides notes, each track can have its own tone number. Then when you play back the tracks together, it sounds like an entire six-piece band. During playback, you can adjust the tempo to change the speed of playback.

	Start	End
Track 1	Auto accompaniment (Rhythm, Bass, Chord 1/2), Keyboard play, Drum pad	→
Track 2	Keyboard play, Drum pad	→
Track 3	Keyboard play, Drum pad	→
Track 4	Keyboard play, Drum pad	→
Track 5	Keyboard play, Drum pad	→
Track 6	Keyboard play, Drum pad	→

Melody data recorded in track.

- NOTES**
- With this keyboard, Track 1 is the basic track, which can be used to record keyboard play, along with Auto Accompaniment and drum pad sounds. Tracks 2 through 6 can be used for keyboard play and Drum pad, so they are called melody tracks. Tracks 2 through 6 are used to add other parts to what is recorded in Track 1.
 - Note that each track is independent of the others. This means that even if you make a mistake while recording, you only need to re-record the track where the mistake was made.
 - You can use different Mixer settings for each track (page E-22).

Selecting a Track

The drum pads function as "memory track buttons," with the pads marked CHORD/1 through CHORD/6 corresponding to Track 1 through Track 6.

Memory Track Buttons

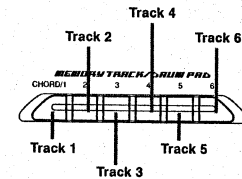

Basic Memory operations

The status of the Memory changes each time you press the MEMORY button.

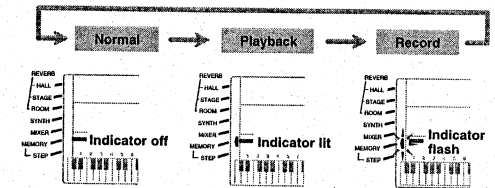

Using Real-time Recording

With real-time recording, the notes you play on the keyboard are recorded as you play them.

To record with real-time recording

1. Press the **MEMORY button** twice to enter record standby.

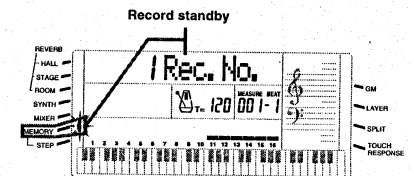

- Perform step 2, below, within five seconds after entering record standby.

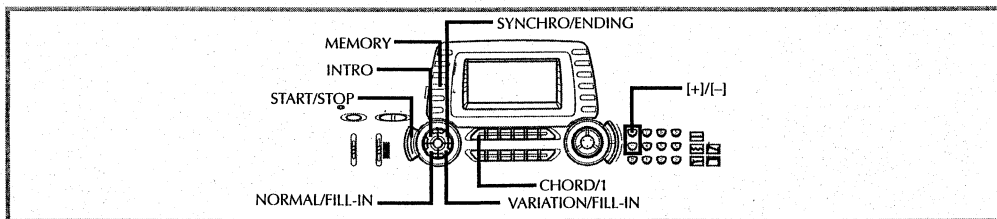

2. Use the [+] and [-] buttons to select a song number.

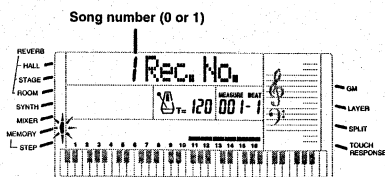

The above song number screen remains on the display for about five seconds. If it disappears before you have a chance to select a song number, use the MEMORY button again to re-display it.

3. Press the CHORD/1 track select button to select Track 1.

- Drum pads function as track select buttons while the keyboard is in record standby.

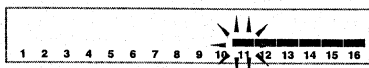

The level meters for tracks 11 through 16 are shown on the display while the keyboard is in record standby, so you can easily check which tracks are already recorded. See "Level Meter Contents During Record/Edit Standby" on page E-39 for details.

4. Make the following settings.

- Tone number
- Rhythm number
- Tempo
- MODE switch

5. Press the START/STOP button to start recording.

6. Play something on the keyboard.

- You can also record Auto Accompaniment chords by selecting the applicable mode with the MODE switch.
- Drum pad, pitch bender, and optional pedal operations are also recorded. See "Track 1 Contents After Real-time Recording".

7. Press the START/STOP button to end recording when you are finish playing.

If you make a mistake while recording, you can stop the record operation and begin over again from step 1, or you can use the editing function (page E-41) to make corrections.

NOTES

- Pressing [V] after step 3 registers the track and switches the track buttons back to their drum pad functions, so you can start recording by playing either a drum pad or the keyboard.
- Using real-time recording to record to a track that already contains recorded data replaces the previous recording with the new one.

Track 1 Contents After Real-time Recording

In addition to keyboard notes and accompaniment chords, the following data is also recorded to Track 1 during real-time recording. This data is applied whenever Track 1 is played back.

- Tone number
- Rhythm number
- Rhythm controller (INTRO button, NORMAL/FILL-IN button, etc.) operations
- Pitch bender operations
- Pedal operations (option)
- Drum pad operations

Touch Response Setting

The touch response setting (on/off) is not recorded.

Mixer Mode Settings

Channel 1 Mixer parameters (page E-24) are automatically recorded to Track 1. You can use the Mixer to change each of the parameters.

Memory Capacity

The keyboard has memory for approximately 4,900 notes. You can use all 4,900 notes for a single song, or you can divide memory between two different songs.

- The measure number and note number flash on the display whenever remaining memory is less than 100 notes.



Recording automatically stops (and auto-accompaniment and rhythm stops playing if they are being used) whenever memory becomes full.

Memory Data Storage

- Whenever you make a new recording, anything previously stored in memory is replaced.
- Memory contents are retained as long as the keyboard is being supplied with electrical power. Unplugging the AC adaptor when batteries are not loaded or when loaded batteries are dead cuts off the keyboard's electrical power supply, clearing all data stored in memory. Plug the keyboard into a wall outlet with the AC adaptor before replacing batteries.
- Turning off the keyboard while a record operation is in progress causes the contents of the track you are currently recording to be lost.
- Remember that you can dump memory contents to another MIDI device using the procedure described under "Dumping Internal Data" on page E-52.

Track 1 Real-time Recording Variations

The following describes a number of different variations you can use when recording to Track 1 using real-time recording. All of these variations are based upon the procedure described under "To record with real-time recording" on page E-33.

To record without rhythm

Skip step 5. Real-time recording without a rhythm starts when you press a keyboard key.

To start recording with synchro start

In place of step 5, press the SYNCHRO/ENDING button. Auto-accompaniment and recording will both start when you play a chord on the accompaniment keyboard.

To record using an intro, ending, or fill-in

During recording, the INTRO, SYNCHRO/ENDING, NORMAL/FILL-IN, and VARIATION/FILL-IN buttons (pages E-19 to 20) can all be used as they normally are.

To synchro start Auto Accompaniment with an intro pattern

In place of step 5, press the SYNCHRO/ENDING button and then the INTRO button. Auto-accompaniment will start with the intro pattern when you play a chord on the accompaniment keyboard.

To start Auto Accompaniment part way into a recording

In place of step 5, press the SYNCHRO/ENDING button and then play something on the melody keyboard to start recording without Auto Accompaniment. When you reach the point where you want accompaniment to start, play a chord on the accompaniment keyboard to start Auto Accompaniment.

Playing Back From Memory

Once you record tracks to memory, you can play them back to see what they sound like.

To play back from memory

1. Use the MEMORY button to enter playback standby, and then use the [+] and [-] buttons to select a song number (0/1).

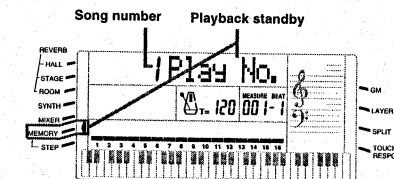

The above song number screen remains on the display for about five seconds. If it disappears before you have a chance to select a song number, use the MEMORY button again to re-display it.

2. Press the START/STOP button to playback the song you selected.

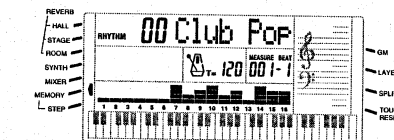

- You can use the TEMPO buttons to adjust the playback tempo.
- Press the START/STOP button again to stop playback.

NOTES

- You can play along on the keyboard using layer (page E-44) and split (page E-45) during playback.
- Pressing the START/STOP button to start playback from memory always starts from the beginning of the song.
- You can set the volume and pan position of the playback tracks using the Mixer. This setting data is output through MIDI OUT.
- The entire keyboard functions as a melody keyboard, regardless of the MODE switch setting.

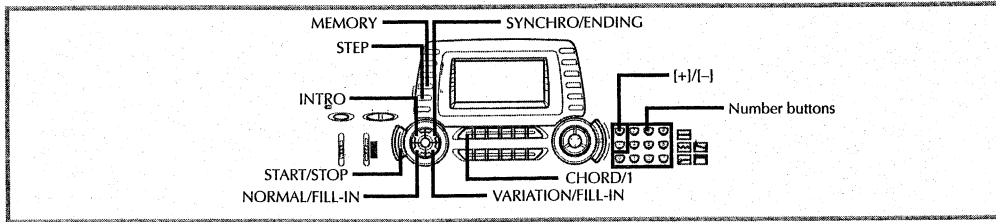

Recording Melody and Chords with Step Recording

With step recording, you can record Auto-Accompaniment chords and notes, and even specify note lengths one by one. Even those who find it difficult to play along on the keyboard with an Auto-Accompaniment can create Auto-Accompaniments based on their own original chord progressions. The following shows the type of data that can be recorded in Tracks 1 through 6.

Track 1: Chords and Auto-Accompaniment
Tracks 2 through 6: Keyboard play, drum pads

With step recording, first record the chords and Auto-Accompaniment in Track 1. Next, record the melody in Tracks 2 through 6.

NOTES

- Use the procedure under "To record to Tracks 2 through 6 using step recording" on page E-39 for details on how to record to Tracks 2 through 6.
- You can use Track 1 for the melody if you do not plan to record chords or Auto-Accompaniment. Select Track 1 and then perform the procedure under "To record to Tracks 2 through 6 using step recording" on page E-39 to record.

To record chords with step recording

- Use the **MEMORY** button to enter record standby, and then use the **[+]** and **[-]** buttons to select a song number (0/1).

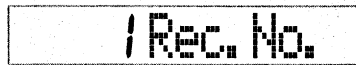

- Press the **CHORD/1** track select button to select Track 1.

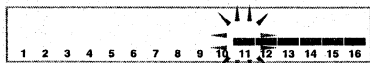

- Press the **STEP** button to start recording.

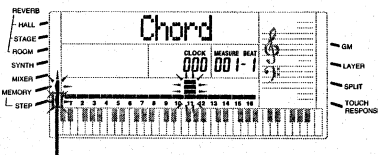

Step recording standby

- Make the following settings.
 - Rhythm number
 - MODE switch
- Press the **SYNCHRO/ENDING** button.
- Play a chord.
 - Use the chord play method that is specified by the current MODE switch setting (FINGERED, CASIO CHORD, etc.).
 - When the MODE switch is set to NORMAL, specify the chord using the root input keyboard and chord type input keyboard. See "Specifying Chords in the Normal Mode" on page E-37 for details.

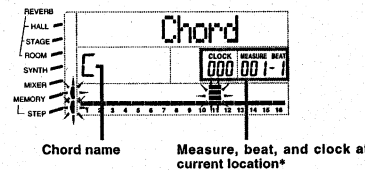

* 48 clocks = 1 beat

- Input the length of the chord (how long it should be played until the next chord is played).
 - Use the number buttons to specify the length of the chord. See "Specifying the Length of a Note" on page E-37 for details.
 - The specified chord and its length are stored in memory and the keyboard stands by for input of the next chord.
 - Repeat steps 6 and 7 to input more chords.
- After you are finished recording, press the **MEMORY** button, **STEP** button, or **START/STOP** button.
 - This enters playback standby for the song you have just recorded.
 - To play back the song at this time, press the **START/STOP** button.

NOTES

- Use the procedure under "Correcting Mistakes While Step Recording" on page E-40 to correct input mistakes you make during step recording.
- You can add on to a track that already contains recorded data by selecting that track in step 2 of the above procedure. Doing so automatically locates the step recording starting point (measure, beat, clock) at the end of the previously recorded data.
- Inputting [0] as the chord length in step 7 of the above procedure specifies a rest, but the rest is not reflected in the accompaniment contents when the accompaniment is played.

* 48 clocks = 1 beat

Track 1 Contents After Step Recording

In addition to chords, the following data is also recorded to Track 1 during step recording. This data is applied whenever Track 1 is played back.

- Rhythm number
- INTRO button, SYNCHRO/ENDING button, NORMAL/FILL-IN button, VARIATION/FILL-IN button operations

Specifying Chords in the Normal Mode

When the MODE switch is set to NORMAL during step recording, you can specify chords using a method that is different from CASIO CHORD and FINGERED fingerings. This chord specification method can be used to input 18 different chord types using only two keyboard keys, so chords can be specified even if you don't know how to actually play them.

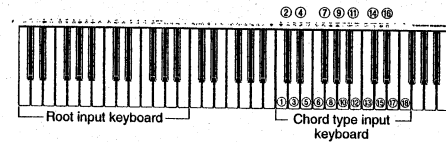

- | | |
|-----------------------|---------------------------|
| ① Major | ⑩ Seventh flat five |
| ② Minor | ⑪ Minor seventh flat five |
| ③ Augmented | ⑫ Seventh suspended four |
| ④ Diminished | ⑬ Diminished seventh |
| ⑤ Suspended four | ⑭ Minor add ninth |
| ⑥ Seventh | ⑮ Add ninth |
| ⑦ Minor seventh | ⑯ Minor sixth |
| ⑧ Major seventh | ⑰ Sixth |
| ⑨ Minor major seventh | ⑱ Six ninth |

To specify a chord, hold down the key on the root input keyboard that specifies the root, and press the key in the chord type input keyboard to specify the chord type. When inputting a chord with a specified bass note, pressing two keys of the root input keyboard causes the lower note to be specified as a bass note.

Example 1: To input Gm7, hold down G on the root input keyboard and press the m7 key on the chord type input keyboard.

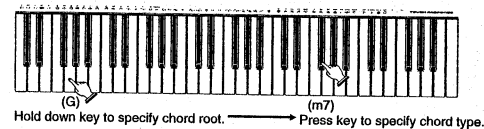

Example 2: To input Gm/C, hold down C and G on the root input keyboard and press the m key on the chord type input keyboard.

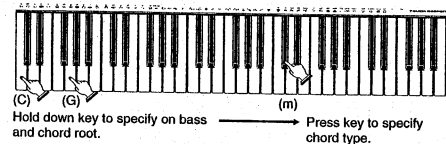

Specifying the Length of a Note

During step recording, the number buttons are used to specify the length of each note.

- Note lengths**
Use number buttons [1] through [6] to specify whole notes (♩), half notes (♪), quarter notes (♫), eighth notes (♮), 16th notes (♯), and 32nd notes (♯).
Example: To specify a quarter note (♫), press [3].
- Dots (•) and triplicates (≡-3-)**
While holding down the [7] (dot) or [9] (triplicate), use buttons [1] through [6] to input the lengths of the notes.
Example: To input a dotted eighth notes (♫), hold down [7] and press [4].
- Ties**
Press [8] and then input the first and then the second note.
Example: To input ♩ ♩, press [8] and then press [4] (note length) while holding down [7] (dot). This note will be tied to the next note you input (16th note in this example).
- Rest**
Hold down [0] and then use number buttons [1] through [9] to specify the length of the rest.
Example: To input an eighth note rest, hold down [0] and press [4].

Track 1 Step Recording Variations

The following describes a number of different variations you can use when recording to Track 1 using step recording. All of these variations are based upon the procedure described under "To record chords with step recording" on page E-36.

To start accompaniment with an intro pattern

In step 5, press the **INTRO** button after the **SYNCHRO/ENDING** button.

To switch to a rhythm variation

In step 6, press the **VARIATION/FILL-IN** button immediately before inputting the chord.

To insert a fill in

In step 6, press the **NORMAL/FILL-IN** or **VARIATION/FILL-IN** button at the measure or beat immediately before the chord or beat where you want to insert the fill in.

To insert an ending

In step 6, press the **SYNCHRO/ENDING** button at the measure or beat immediately before the chord where you want to insert the ending.

IMPORTANT!

The length of the ending depends on the rhythm you are using. Check the length of the pattern you are using and set the length of the chord accordingly in step 7. Making the chord too short in step 7 can result in the ending pattern being cut off.

To step record chords without rhythm

Skip step 5. The specified chord of the length specified by the number buttons is recorded. A rest can be specified here, so an original chord pattern can be created.

To add chord accompaniment part way through rhythm play

In Place of step 5 at the start of the recording, press the **NORMAL/FILL-IN** button (or the **VARIATION/FILL-IN** button if you want to use a variation rhythm) and input rests. Then in step 6, input the chords. Only rhythm is played where you input the rests, and then chord play starts after the rests.

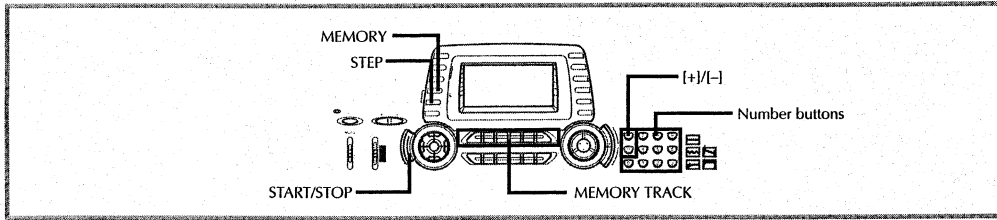

Recording Multiple Tracks

Track 1 of the keyboard's memory records Auto Accompaniment and keyboard play. In addition, there are five other melody tracks that you can use to record melody parts only. You can record different tones to the melody tracks and build a full ensemble of instruments for your recordings. The procedure you use for recording to Tracks 2 through 6 is identical to the one you use when recording to Track 1.

To record to Tracks 2 through 6 using real-time recording

You can record to Tracks 2 through 6 while playing back what you originally recorded on Track 1 and any other tracks that are already recorded.

1. Use the **MEMORY** button to enter record standby, and then use the **[+]** and **[-]** buttons to select a song number (0/1).
 - The song number you select should be the one where you previously input Track 1.



2. Use the **MEMORY TRACK** buttons to select the track you want to record to (2 through 6).
Example: Select Track 2.

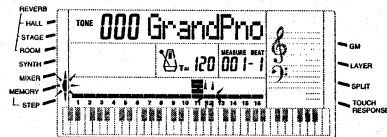

While the keyboard is in record standby, the display shows the level meters for channels 11 through 16, so you can check which tracks have already been recorded. See "Level Meter Contents During Record/Edit Standby" on page E-39 for details.

3. Make the following settings.
 - Tone number
 - Tempo (to set playback of the recorded tracks to a tempo that is easy for you to follow)
4. Press the **START/STOP** button to start recording.
 - At this time, the contents of any tracks that are already recorded start to play back.
 - Any drum pad, pitch bender, or optional pedal operations you perform are also recorded.

5. Use the keyboard to play what you want to record the track you selected.

6. Press the **START/STOP** button to end recording when you are finished.

Track Contents After Real-time Recording

In addition to keyboard notes, the following data is also recorded to the selected track during real-time recording. This data is applied whenever the track is played back.

- Tone number
- Optional pedal operations
- Pitch bender operations
- Drum pad operations

To record to Tracks 2 through 6 using step recording

This procedure describes how to input notes one-by-one, specifying each note's pitch and length.

1. Use the **MEMORY** button to enter record standby, and then use the **[+]** and **[-]** buttons to select a song number (0/1).
 - The song number you select should be the one where you previously input Track 1.



2. Use the **MEMORY TRACK** buttons to select the track you want to record to (2 through 6).
Example: Select Track 2.

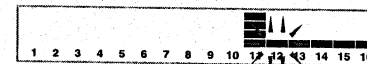

3. Press the **STEP** button to start recording.

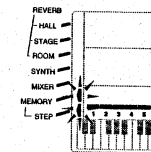

4. Specify a tone number.
 - After changing the tone number, press any keyboard key to clear the tone number and name screen, and return to the note input screen.
5. Use the keyboard keys or the **[+]** and **[-]** buttons to input notes, or the **[0]** button to input rests.
 - When touch response is turned on, the amount of pressure you use to press the keys is also recorded. You can also use keyboard keys to input chords.
 - With **[+]**/**[-]** button input, a staff appears on the display, showing you the note you are inputting.
 - To cancel input of a rest, press **[0]** again.
6. Use **number buttons** [1] through [9] to input the length of the note or rest (page E-37).
7. Repeat steps 5 and 6 to input more notes.
8. Press the **START/STOP** button to end recording when you are finished.

NOTES

- Use the procedure under "Correcting Mistakes While Step Recording" on page E-40 to correct input mistakes you make during step recording.
- You can add on to a track that already contains recorded data by selecting that track in step 2 of the above procedure. Doing so automatically locates the step recording starting point (measure, beat, clock) at the end of the previously recorded data.
- To record a drum pad part, tap a drum pad in step 5.
- Whenever you are recording to Tracks 2 through 6, the entire keyboard functions as a melody keyboard, regardless of the current MODE switch setting.

Track Contents After Step Recording

In addition to notes and rests, the following data is also recorded to the track during step recording. This data is applied whenever the track is played back.

- Tone number
- Drum pad operations

To turn off a specific track

Use the Mixer (Page E-22) to turn off the channel that corresponds to the track you want to turn off.

Level Meter Contents During Record/Edit Standby

Channels 11 through 16 correspond to Tracks 1 through 6. Whenever the keyboard is in record or edit (page E-41) standby, the level meter display shows which tracks already contain recorded data and which are still empty. Tracks with four lit segments already contained recorded data, while tracks with one lit segment are not yet recorded.

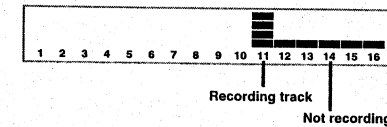

- See "NAVIGATE TRACK" on page E-51 for details on selecting the track whose note data is shown on the display.

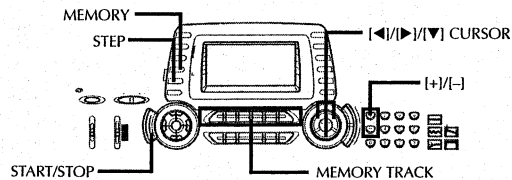

Correcting Mistakes While Step Recording

Memory data can be thought of as a musical score that progresses from left to right, with the input point normally at the far right of the recorded data.

The procedure described here lets you move the input point to the left in order to make changes in data you have already input. Note, however, that moving the input point to the left and changing data automatically deletes all of the data recorded to the right of the input point.

To correct mistakes while step recording

- Without exiting step recording, use the [◀] button to move the input point to the left.

- The data recorded at the location where the input point is currently located appears on the display. You can use [◀] and [▶] to move left and right through the data.

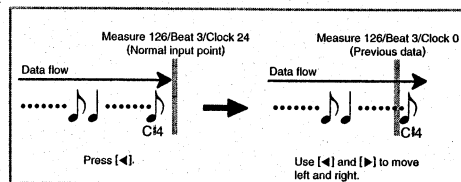
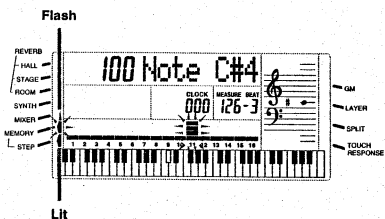

- Monitoring the data on the display, use [◀] and [▶] to move the input point to the data you want to change.

Example: To re-record all note data following the note A3 located at Measure 120, Beat 1, Clock 0.

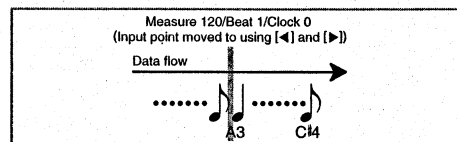
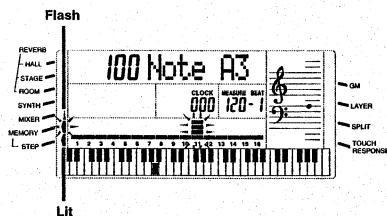

- When the input point is located where you want to start your change from, press the [+] and [-] buttons at the same time.

Rewrite?

- Press [▼] to clear all data to the right of the current input point location, and enter step recording standby.

- Pressing [◀], [▶], [+], or [-] in place of [▼] cancels the rewrite operation without deleting anything. After that, you can use [◀] and [▶] to move the input point to another location if you want.

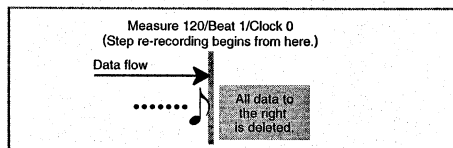

NOTE

The message "TrackEnd" appears on the display whenever you use [▶] to move the input point back to its normal position, all the way to the right of the data already recorded in memory.

Editing Memory Contents

After you record to keyboard memory, you can recall individual notes and parameter settings (such as tone number) and make any changes you want. This means you can correct misplayed notes, make changes in tone selections, etc.

The following types of data can be edited.

- Note intensity
- Notes
- Chords
- Tone numbers
- Rhythm number
- Rhythm controller operations (INTRO button, NORMAL/FILL-IN button, etc.)
- Drum pad operations

To edit memory contents

- Use the MEMORY button to enter playback standby, and then use [+] and [-] to select a song number (0/1).

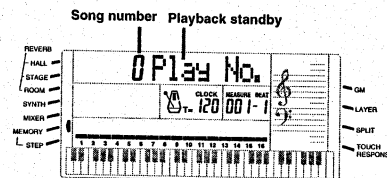

- Press the STEP button.

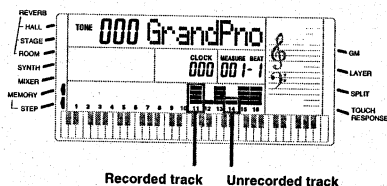

- Use the MEMORY TRACK buttons to select the recorded track that you want to edit.

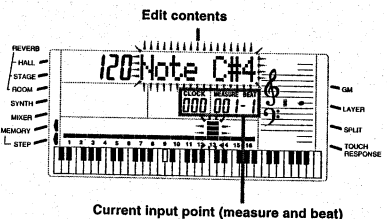

- Use the [◀] and [▶] CURSOR buttons to move to the location in track where the note or parameter you want to change is located.

[Note editing example]

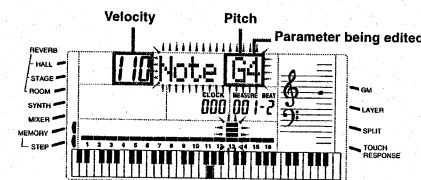

The flashing location on the display indicates the parameter that is currently selected for editing.

When editing a note, press the [▼] CURSOR key to select the [Velocity] and [Pitch] parameters.

- Make any changes in the value that you want.

- The actual procedures you use to change a parameter depend on the type of data it contains. See "Editing Techniques and Display Contents" on page E-42 for details.



- Repeat steps 4 and 5 to edit other parameters.

- Press the START/STOP button to end editing when you are finished.

NOTES

- Interrupting playback of a song and immediately starting an editing operation causes the point where playback was interrupted to appear first on the editing screen.
- The only parameters that can be edited for Tracks 2 through 6 are notes, tone numbers, and drum pad operations.
- In the case of real-time recording, you later can change tone numbers you specified while recording to Tracks 1 through 6 is in progress. You cannot change the tone you selected before starting the recording session.
- With step recording, you later can change any tone number you specify while recording is in progress. This includes the tone number you specify before you start recording, as well as any tone numbers you specify while recording is in progress. Note, however, that if you start recording with the default tone number (without specifying a tone number), you will not be able later to change the default tone to another one, but you still will be able to change tone numbers you specify while recording is in progress.
- In the case of real-time recording, you later can change rhythm numbers you specified while recording to Track 1 is in progress. You cannot change the rhythm you selected before starting the recording session.
- With step recording, you later can change any rhythm number you specified for recording to Track 1. This includes the rhythm number you specify before you start recording, as well as any rhythm numbers you specify while recording is in progress. Note, however, that if you start recording with the default rhythm number (without specifying a rhythm number), you will not be able later to change the default rhythm to another one, but you still will be able to change rhythm numbers you specify while recording is in progress.
- You cannot use the edit procedure to add more data to a recording.
- You cannot move portions of a recording to a different location within the recording.
- Note lengths cannot be changed.

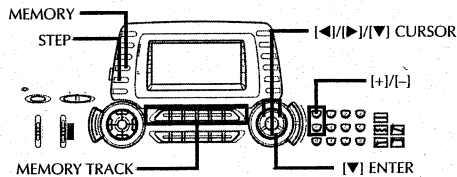

Editing Techniques and Display Contents

The following describes the editing techniques you can use to change the various parameters stored in memory.

■ To change the key pressure (velocity) of a note

Use the keyboard keys, number buttons or [+] and [-] to adjust the key pressure. If you use the keyboard keys to adjust key pressure, you first have to turn on touch response.

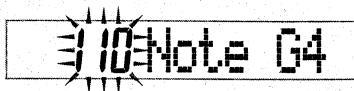

■ To change the pitch of a note

Input a new note on the keyboard or use [+] and [-] buttons to change the pitch of a note. The pitch you specify here is reflected in the keyboard and the notes shown in the staff on the display.



IMPORTANT!

Whenever editing memory contents, never change a note so it is identical to the note before or after it. Doing so may alter the length of the changed note and the note before or after it. Should this happen, you will have to re-record the entire track.

■ To change a chord

Use the chord fingering method selected by the MODE switch (FIN-GERED, CASIO CHORD, etc.) to input a chord.

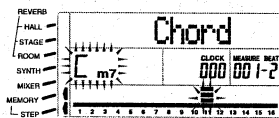

■ To change a tone number

Use the number buttons or [+] and [-] buttons to change a tone number.

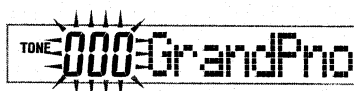

NOTES I

- In the case of real-time recording, you later can change tone numbers you specified while recording to Tracks 1 through 6 is in progress. You cannot change the tone you selected before starting the recording session.

- With step recording, you later can change any tone number you specified for recording to Tracks 2 through 6. This includes the tone number you specify before you start recording, as well as any tone numbers you specify while recording is in progress. Note, however, that if you start recording with the default tone number (without specifying a tone number), you will not be able later to change the default tone to another one, but you still will be able to change tone numbers you specify while recording is in progress.

■ To change a rhythm number

Use the number buttons or [+] and [-] buttons to change a rhythm number.

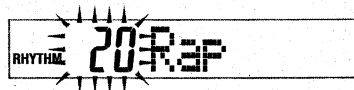

NOTES I

- In the case of real-time recording, you later can change rhythm numbers you specified while recording to Track 1 is in progress. You cannot change the rhythm you selected before starting the recording session.
- With step recording, you later can change any rhythm number you specify before you start recording, as well as any rhythm numbers you specify while recording is in progress. Note, however, that if you start recording with the default rhythm number (without specifying a rhythm number), you will not be able later to change the default rhythm to another one, but you still will be able to change rhythm numbers you specify while recording is in progress.

■ To change a rhythm controller * operation

* [INTRO, NORMAL/FILL-IN, VARIATION/FILL-IN, SYNCHRO/ENDING]

Press the rhythm controller button you want to change to.

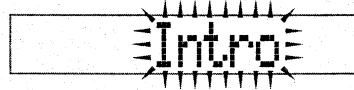

■ To change a drum pad operation

Press the drum pad you want to change to.



Mixer Editable Data

The Mixer can be used to edit tone and other data for each track. The following is a list of data that can be edited with the Mixer. Note, however, that edited data cannot be save. See "Mixer Function" on page E-22 for details.

- Program Change Number (tone setting)
- Volume
- Pan Pot
- Fine Tune
- Coarse Tune
- Expressions

Deleting Individual Data Items from Memory

The following procedure (which is similar to the editing procedure described on page E-41) can be used to delete recorded data items one-by-one from memory.

To delete individual data items from memory

- Use the MEMORY button to enter playback standby, and then use [+] and [-] to select a song number (0/1).

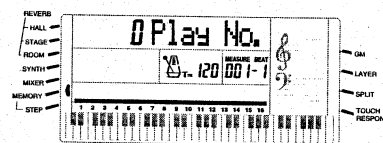

- Press the STEP button to enter edit standby.

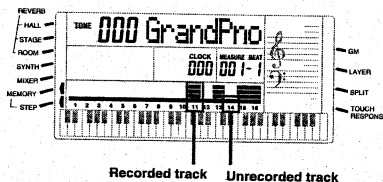

- Use the MEMORY TRACK buttons to select the recorded track whose data you want to delete.

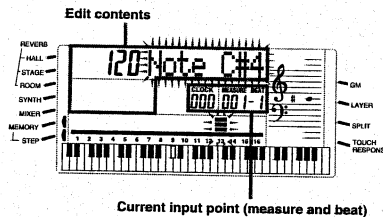

- Use the [◀] and [▶] CURSOR buttons to move to the location in track where the data you want to delete is located.

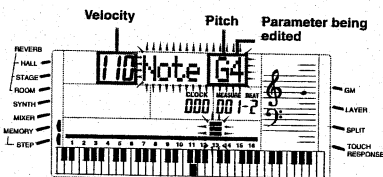

- Press the [+] and [-] buttons at the same time.

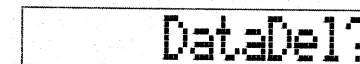

- Press the [▼] ENTER button to delete the selected data.
 - Press the [◀], [▶], [+], or [-] button in place of [▼] to abort the procedure without deleting anything.

NOTE I

Deleting all data automatically puts the keyboard into playback standby.

Deleting All of the Data in a Specific Track

Use the following procedure to delete all of the data currently recorded in a specific track.

To delete all of the data in a specific track

- Use the MEMORY button to enter record standby, and then use [+] and [-] to select a song number (0/1).

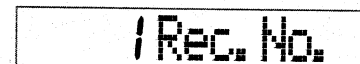

- Hold down the MEMORY button to enter track delete standby.

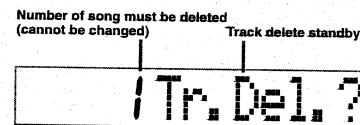

- Release the MEMORY button after the "Del.?" message appears.

- Use the MEMORY TRACK buttons to select the recorded track or tracks whose data you want to delete.

Track delete standby

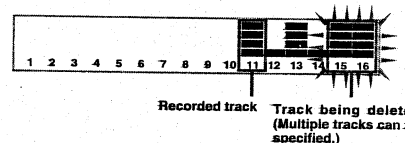

- You can specify more than one track for deletion by pressing more than one track select button.
- To deselect a track, simply press its track select button again.

- Press the [▼] ENTER button to delete the data in the selected track or tracks.

NOTES I

- If you leave the keyboard in track delete standby for about five seconds without doing anything, standby is automatically cleared.
- You cannot change the song number while in track delete standby.
- In the above procedure, you cannot select any track that does not contain any recorded data.
- Pressing the MEMORY button while in track delete standby returns to record standby.

Keyboard Settings

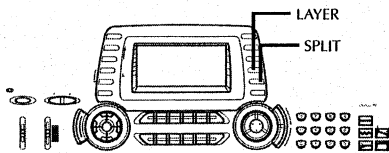

This section describes how to use layer (to play two tones with a single key) and split (to assign different tones to either end of the keyboard), and how to make touch response, transpose, and tuning settings.

Using Layer

Layer lets you assign two different tones (a main tone and a layered tone) to the keyboard, both of which play whenever you press a key. For example, you could layer the FRENCH HORN tone on the BRASS tone to produce a rich and brassy sound.

LAYER

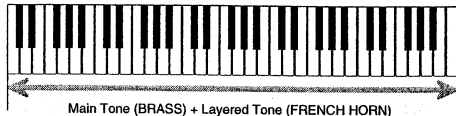

To layer tones

1. First select the main tone.
Example: To select "061 BRASS" as the main tone, press the TONE button and then use the number buttons or [+] and [-] buttons to input 0, 6 and then 1.

TONE 061 Brass

2. Press the LAYER button.

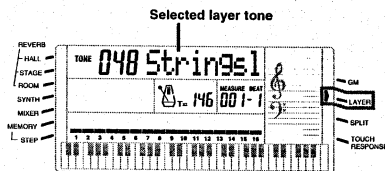

3. Select the layered tone.

Example: To select "060 FRENCH HORN" as the layered tone, use the number buttons or [+] and [-] buttons to input 0, 6 and then 0.

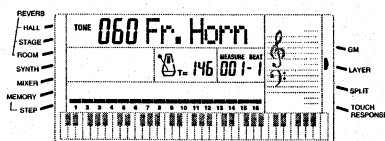

4. Now try playing something on the keyboard.

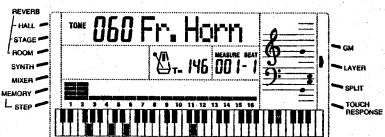

- Both tones are played at the same time.

5. Press the LAYER button again to unlayer the tones and return the keyboard to normal.

NOTES

- The main tone sounds over Channel 1, while the layered tone sounds over Channel 2. You can also use the Mixer to change the tone and volume settings for these channels.
- Layer cannot be used while standing by for recording or while recording is being performed in the Memory Mode.

Using Split

With split you can assign two different tones (a main tone and a split tone) to either end of the keyboard, which lets you play one tone with your left hand and another tone with your right hand. For example, you could select STRINGS as the main (high range) tone and PIZZICATO as the split (low range) tone, putting an entire string ensemble at your fingertips. Split also lets you specify the split point, which is the location on the keyboard where the changeover between the two tones occurs.

SPLIT

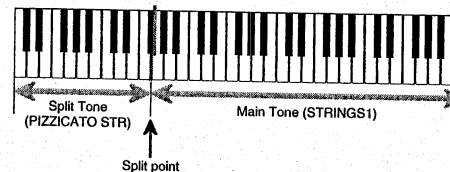

To split the keyboard

1. First select the main tone.
Example: To select "048 STRINGS1" as the main tone, press the TONE button and then use the number buttons or [+] and [-] buttons to input 0, 4 and then 8.

TONE 048 Strings1

2. Press the SPLIT button.

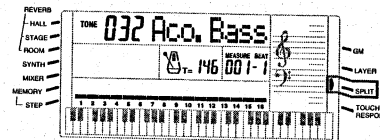

3. Select the split tone.
Example: To select "045 PIZZICATO STR" as the split tone, use the number buttons or [+] and [-] buttons to input 0, 4 and then 5.

TONE 045 Pizz. Str

4. Specify the split point. While holding down the SPLIT button, press the keyboard where you want the leftmost key of the high end range to be.
Example: To specify G3 as the split point, press the G3 key.

G3

5. Now try playing something on the keyboard.
 - Every key from F#3 and below is assigned the PIZZICATO tone, while every key from G3 and above is assigned the STRINGS tone.
6. Press the SPLIT button again to unsplit the keyboard and return it to normal.

NOTES

- The main tone sounds over Channel 1, while the split tone sounds over Channel 3. You can also use the Mixer to change the tone and volume settings for these channels.
- Split cannot be used while standing by for recording or while recording is being performed in the Memory Mode.

Using Layer and Split Together

You can use layer and split together to create a layered split keyboard. It makes no difference whether you layer tones first and then split the keyboard, or split the keyboard and then layer tones. When you use layer and split in combination, the high range of the keyboard is assigned two tones (main tone + layered tone), and the low range two tones (split tone + layered split tone).

LAYER SPLIT

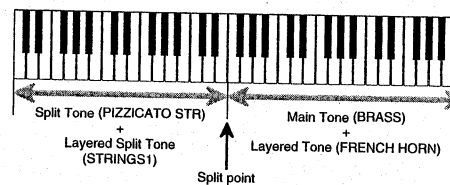

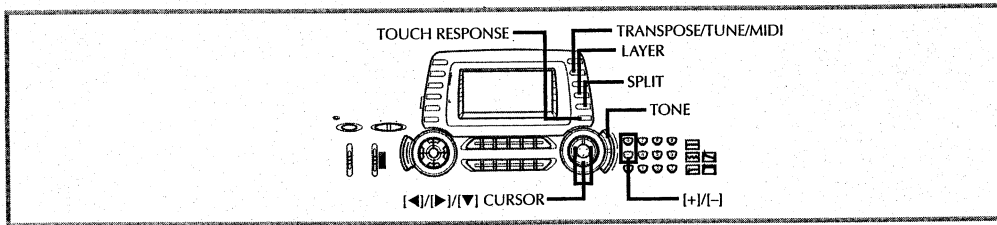

To split the keyboard and then layer tones

1. Press the **TONE** button and then input the tone number of the main tone.



2. Press the **SPLIT** button and then input the number of the split tone.

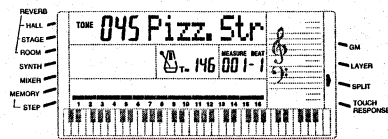

- After specifying the split tone, press the **SPLIT** button to unsplit the keyboard.

3. Press the **LAYER** button and then input the number of the layered tone.
 - Note that you can reverse steps 2 and 3, specifying the layered tone first and then the split tone.

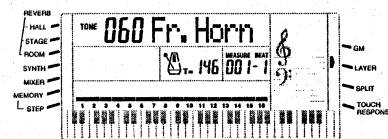

4. Press the **SPLIT** button or the **LAYER** button so both of the **SPLIT** and **LAYER** indicators are displayed.

5. Input the number of the layered split tone.



6. Specify the split point. While holding down the **SPLIT** button, press the keyboard where you want the leftmost key of the low end range to be.
7. Play something on the keyboard.
 - Press the **LAYER** button to unlayer the keyboard, and the **SPLIT** button to unsplit it.

NOTE

The main tone sounds over Channel 1, the layer tone over Channel 2, the split tone over Channel 3, and the layer/split tone over Channel 4. You can also use the Mixer to change the tone and volume settings for these channels.

Using Touch Response

When touch response is turned on, the relative volume of sound output by the keyboard is varied in accordance with the amount of pressure applied, just like an acoustic piano.

To turn touch response on and off

Press the **TOUCH RESPONSE** button to toggle touch response on and off.

- Touch response is on when touch response indicator is on.

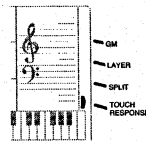

- Touch response is off when touch response indicator is off.

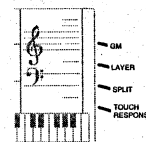

NOTES

- Touch response not only affects the keyboard's internal sound source, it also is output as MIDI data.
- Memory playback, accompaniment, and external MIDI note data does not affect the touch response setting.

Transposing the Keyboard

Transpose lets you raise and lower the overall key of the keyboard in semitone units. If you want to play an accompaniment for a vocalist who sings in a key that's different from the keyboard, for example, simply use transpose to change the key of the keyboard.

To transpose the keyboard

1. Press the **TRANSPOSE/TUNE/MIDI** button until the transpose screen appears on the display.

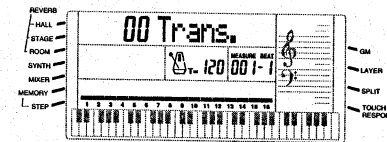

2. Use **+** and **-** to change the transpose setting of the keyboard.

Example: To transpose the keyboard five semitones upwards.

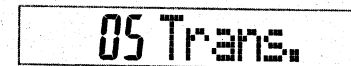

NOTES

- The keyboard can be transposed within a range of -12 (one octave downwards) to +12 (one octave upwards).
- The default transpose setting is "00" when keyboard power is turned on.
- If you leave the transpose screen on the display for about five seconds without doing anything, the screen is automatically cleared.
- The transpose setting also affects playback from memory and Auto Accompaniment.

Tuning the Keyboard

The tuning feature lets you fine tune the keyboard to match the tuning of another musical instrument.

To tune the keyboard

1. Press the **TRANSPOSE/TUNE/MIDI** button.
2. Use the **[◀]** and **[▶]** CURSOR buttons to display the tuning screen.



3. Use **+** and **-** to change the tuning setting of the keyboard.

Example: To lower the tuning by 20.



NOTES

- The keyboard can be tuned within a range of -50 cents to +50 cents. *100 cents is equivalent to one semitone.
- The default tuning setting is "00" when keyboard power is turned on.
- If you leave the tuning screen on the display for about five seconds without doing anything, the screen is automatically cleared.
- The tuning setting also affects playback from memory and Auto Accompaniment.

What is MIDI?

The letters MIDI stand for Musical Instrument Digital Interface, which is the name of a worldwide standard for digital signals and connectors that makes it possible to exchange musical data between musical instruments and computers (machines) produced by different manufacturers. MIDI compatible equipment can exchange keyboard key press, key release, tone change, and other data as messages.

Though you do not need any special knowledge about MIDI to use this keyboard as a stand-alone unit, MIDI operations require a bit of specialized knowledge. This section provides you with an overview of MIDI that will help to get you going.

MIDI Connections

MIDI messages are sent out through the MIDI OUT terminal of one machine to the MIDI IN terminal of another machine over a MIDI cable. To send a message from this keyboard to another machine, for example, you must use a MIDI cable to connect the MIDI OUT terminal of this keyboard to the MIDI IN terminal of the other machine. To send MIDI messages back to this keyboard, you need to use a MIDI cable to connect the other machine's MIDI OUT terminal to the MIDI IN terminal of this keyboard.

To use a computer or other MIDI device to record and playback the MIDI data produced by this keyboard, you must connect the MIDI IN and MIDI OUT terminals of both machines in order send and receive data.

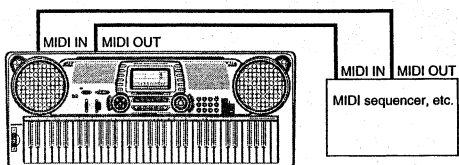

If a MIDI THRU function provided by the software is being run on a connected computer or other MIDI device, be sure to turn this keyboard's LOCAL CONTROL off (page E-51).

MIDI Channels

MIDI allows you to send the data for multiple parts at the same time, with each part being sent over a separate MIDI channel. There are 16 MIDI channels, numbered 1 through 16, and MIDI channel data is always included whenever you exchange data (key press, pitch bend operation, etc.).

Both the sending machine and the receiving machine must be set to the same channel for the receiving unit to correctly receive and play data. If the receiving machine is set to Channel 2, for example, it receives only MIDI Channel 2 data, and all other channels are ignored.

This keyboard is equipped with multi-timbre capabilities, which means it can receive messages over all 16 MIDI channels and play up to 16 parts at the same time. Tone and volume settings for each channel can be made using the keyboard's onboard Mixer, or by an external source that sends required MIDI control messages.

Keyboard and bend operations performed on this keyboard are sent out by selecting a MIDI channel (1 to 16) and then sending the appropriate message.

General MIDI

General MIDI standardizes MIDI data for all sound source types, regardless of manufacturer. General MIDI specifies such factors as tone numbering, drum sounds, and available MIDI channels for all sound sources. This standard makes it possible for all MIDI equipment to reproduce the same nuances when playing General MIDI data, regardless of the manufacturer of the sound source. This keyboard supports General MIDI, so it can be used to play commercially available pre-recorded General MIDI data and General MIDI data sent to it from a personal computer.

Messages

There is a wide variety of messages defined under the MIDI standard, and this section details the particular messages that can be sent and received by this keyboard. An asterisk is used to mark messages that affect the entire keyboard. Messages without an asterisk are those that affect only a particular channel.

NOTE ON/OFF

This message sends data when a key is pressed (NOTE ON) or released (NOTE OFF).

A NOTE ON/OFF message include a note number (to indicate note whose key is being pressed or released) and velocity (keyboard pressure as a value from 1 to 127). NOTE ON velocity is always used to determine the relative volume of the note. This keyboard does not receive NOTE OFF velocity data. Whenever you press or release a key on this keyboard, the corresponding NOTE ON or NOTE OFF message is sent from the MIDI OUT terminal.

NOTE

The pitch of a note depends on the tone that is being used, as shown in the Note Table on page A-1. Whenever this keyboard receives a note number that is outside its range for that tone, the same tone in the nearest available octave is substituted.

PROGRAM CHANGE

This is the tone selection message. PROGRAM CHANGE can contain tone data within the range of 0 to 127.

A PROGRAM CHANGE message is sent out through this keyboard's MIDI OUT terminal whenever you manually change its tone number. Receipt of a PROGRAM CHANGE message from an external machine changes the tone setting of this keyboard.

PITCH BEND

This message carries pitch bend information for smoothly sliding the pitch upwards or downwards during keyboard play. Performing a pitch bend operation on this keyboard causes simultaneously changes the pitch of the built-in sound source and sends a PITCH BEND message out through the MIDI OUT terminal.

CONTROL CHANGE

This message adds effects such as vibrato and volume changes applied during keyboard play. CONTROL CHANGE data includes a control number (to identify the effect type) and a control value (to specify the on/off status and depth of the effect).

The following is a list of data that can be sent or received using CONTROL CHANGE.

Effect	Control Number
BANK SELECT *	0, 32
VOLUME	7
PAN	10
EXPRESSION	11
HOLD1	64
SOSTENUTO	66
SOFT PEDAL	67
RPN *	100/101
DATA ENTRY	6/38

*1 The BANK SELECT setting of PROGRAM CHANGE can be used to access any of this keyboard's 200 tones when selecting tones on this keyboard from an external machine.

Bank 0: 128 General MIDI tones (PROGRAM CHANGE 0 to 127)

Bank 1: 32 synthesized tones (PROGRAM CHANGE 0 to 31)

Bank 2: 8 drum sets (PROGRAM CHANGE 0 to 7)

Bank 3: 32 user tones (PROGRAM CHANGE 0 to 31)

Immediately prior to sending the PROGRAM CHANGE message, send two successive CONTROL CHANGE messages containing the following data.

CONTROL NUMBER= 0, CONTROL VALUE= <bank number>
CONTROL NUMBER= 32, CONTROL VALUE= 0

Example: To select tone number 190 (user tone 22) from an external MIDI machine.

CONTROL NUMBER= 0, CONTROL VALUE= 3
(bank number)

CONTROL NUMBER= 32, CONTROL VALUE= 0
PROGRAM CHANGE= 22

*2 RPN stands for Registered Parameter Number, which is a special control change number used when combining multiple control changes. The parameter being controlled is selected using the control values of control numbers 100 and 101, and then settings are made using the control values of DATA ENTRY (control numbers 6 and 38).

This keyboard supports pitch bend sense, transpose, and tune control RPN sent from other MIDI machines.

ALL SOUND OFF

This message forces all sound being produced over the current channel to turn off, regardless of how the sound is being produced.

ALL NOTES OFF

This message turns off all note data sent from an external device and currently being sounded on the channel.

Any notes being sustained using a sustain pedal or sostenuto pedal continue to sound until the next pedal off.

RESET ALL CONTROLLERS

This messages initializes pitch bend and all other control changes.

SYSTEM EXCLUSIVE*

This message is used to control system exclusives, which are tone fine adjustments that are unique to a particular machine. Originally, system exclusives were unique to a particular model, but now there are also universal system exclusives that are applicable to machines that are different models and even produced by different manufacturers.

The following are the system exclusive messages supported by this keyboard.

GM MODE ON ((F0)7E)7F(09)01(F7)

GM MODE ON is used by an external machine to turn on this keyboard's GM system. GM stands for General MIDI.

GM MODE ON takes more time to process than other messages, so when GM MODE ON is stored in the sequencer it can take more than 100msec until the next message.

GM MODE OFF ((F0)7E)7F(09)02(F7)

GM MODE OFF is used by an external machine to turn off this keyboard's GM system.

REVERB CHANGE ((F0)44)0E(09)yy(F7)

REVERB CHANGE switches the keyboard's internal digital reverbs. The [yy] parameter in the syntax noted in the title stands for a hexadecimal value that represents a reverb number sent from an external machine. The following shows the hexadecimal values that can be specified and their meanings.

Hex. Value	Digital Reverb	Reverb Number
00	Room	0
01	Stage	1
02	Hall	2
0F	Off	Off

NOTES

- MIDI Channel 10 is reserved for drum sounds only, so it is not necessary to send bank select data when changing tones.
- Sustain, sostenuto, and soft effects produced by the foot pedal can also be sent and received (Control Numbers 64, 66, 67 respectively).

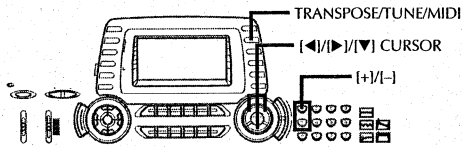

Changing MIDI Settings

This keyboard lets you change a number of MIDI parameters, including GM MODE ON/OFF, PITCH BEND, and others. Parameters are divided into two groups: Group 1 parameters (accessed by pressing the TRANSPOSE/TUNE/MIDI button twice), and Group 2 parameters (accessed by pressing the TRANSPOSE/TUNE/MIDI button three times).

To change MIDI parameters

1. Press the TRANSPOSE/TUNE/MIDI button either twice or three times to select the parameter group you want.

Group 1: GM MODE, KEYBOARD CHANNEL, MIDI IN CHORD JUDGE, LOCAL CONTROL, ACCOMP MIDI OUT

Group 2: PITCH BEND RANGE, NAVIGATE TRACK, ASSIGNABLE JACK TERMINAL

Example: To select Group 1.

off GM Mode

2. Use the [◀] and [▶] CURSOR buttons to select the parameter you want to change.

See "Parameters and Their Displays" for details on parameters.

Example: To select the KEYBOARD CHANNEL parameter.

01 Keybd Ch

3. Use [+] and [-] to change the setting of the parameter.
Example: To change the KEYBOARD CHANNEL parameter value to 2.

02 Keybd Ch

- If you accidentally go past the group you want, keep pressing the TRANSPOSE/TUNE/MIDI button until the group you want reappears on the display.
- If you leave the parameter selection screen on the display for about five seconds without doing anything, the parameter selection screen is automatically cleared.

Parameters and Their Displays

Group 1

The Group 1 parameter selection screen is displayed by pressing the TRANSPOSE/TUNE/MIDI button twice.

■ GM MODE ON/OFF (Default: off)

on: Turns GM MODE on. Select this setting when you want to listen to GM data on an external machine. Turning GM MODE on automatically turns MIDI IN CHORD JUDGE off (if it is on), because GM MODE and MIDI IN CHORD JUDGE cannot be used at the same time.

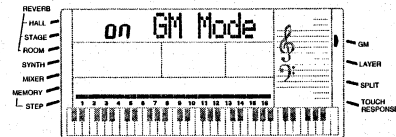

off: Turns GM MODE off. The tone, volume and other parameter settings of each channel are initialized. When the received MIDI data is played, the piccolo tone is raised by one octave.

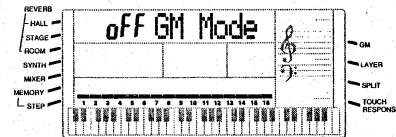

■ KEYBOARD CHANNEL (Basic Channel) (Default: 01)

This parameter sets the channel for sending keyboard, pitch bender, and other MIDI messages.

10 Keybd Ch

■ MIDI IN CHORD JUDGE ON/OFF (Default: off)

on: The keyboard determines basic channel note data as auto accompaniment chords in accordance with the chord fingering method selected by the MODE switch. Turning GM MODE on automatically turns MIDI IN CHORD JUDGE off, because GM MODE and MIDI IN CHORD JUDGE cannot be used at the same time.

on Chord

off: Turns MIDI IN CHORD JUDGE off.

off Chord

■ LOCAL CONTROL ON/OFF (Default: on)

on: Turns LOCAL CONTROL on, which sends data generated by the keyboard or drum pads simultaneously to the keyboard's local sound source and as a MIDI message from the MIDI OUT terminal.

on Local

off: Turns LOCAL CONTROL off, which sends data generated by the keyboard or drum pads as a MIDI message from the MIDI OUT terminal, but not to the keyboard's local sound source. Turn off LOCAL CONTROL whenever using MIDI THRU on an externally connected machine.

off Local

■ ACCOMP MIDI OUT ON/OFF (Default: off)

on: Turns ACCOMP MIDI OUT on, which sends a MIDI message from the MIDI OUT terminal whenever Auto Accompaniment plays.

on AcompOut

off: Turns ACCOMP MIDI OUT off, which does not send a MIDI message from the MIDI OUT terminal whenever Auto Accompaniment plays.

off AcompOut

Group 2

The Group 2 parameter selection screen is displayed by pressing the TRANSPOSE/TUNE/MIDI button three times.

■ PITCH BEND RANGE (Default: 02)

This parameter sets the range maximum change by the pitch bender in a range of 01 (1 semitone) to 12 (12 semitones).

02 Bend

■ NAVIGATE TRACK (Default: 1)

This parameter specifies whether or not the number of the memory tracks (1 through 6) whose data is being played back should be displayed on the screen.

Immediately after you finish a record or track edit operation, the last track you recorded to automatically becomes the navigate track.

1 Navi. Tr.

■ ASSIGNABLE JACK TERMINAL (Default: SUS)

This parameter specifies the function of the foot pedal.

See page E-13 for details on each of the available foot pedal functions.

SUS (sustain): Specifies that a sustain effect should be applied when the pedal is depressed.

SUS Jack

SoS (sostenuto): Specifies that a sostenuto effect should be applied when the pedal is depressed.

SoS Jack

Sft (soft): Specifies that a soft effect should be applied when the pedal is depressed.

Sft Jack

rHy (rhythm): Specifies that the pedal should operate like the START/STOP button.

rHy Jack

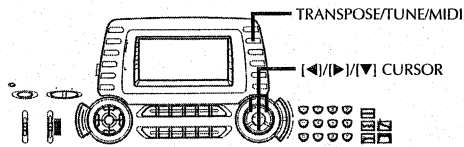

Dumping Internal Data

This keyboard stores a variety of internal data, including data recorded to memory and synthesizer data. This data can be sent and received in bulk as MIDI exclusive data through the MIDI terminals. This capability makes it possible for you to use a computer or other MIDI machine as an external storage device for your data. Before performing the following procedures, you must first connect this keyboard's MIDI IN and MIDI OUT terminals to an external machine using MIDI cables.

Some software does not support MIDI exclusive data.

To dump data from the keyboard to an external machine

- Set up the other machine by putting it in its receive standby mode.
 - See the documentation that comes with the other machine for details.
- Starting from the keyboard's normal mode, press the **TRANPOSE/TUNE/MIDI button** four times to display the data dump screen.
- Press the **[▼] CURSOR button** to start data send.
 - The keyboard automatically returns to its normal mode after all the data is sent.

To import dumped data from another machine

- Starting from the keyboard's normal mode, press the **TRANPOSE/TUNE/MIDI button** four times to display the data dump screen.
- Use the **[◀] and [▶] CURSOR buttons** to change to the dumped data import screen, indicated by the message "BulkRcv?".
- Press the **[▼] CURSOR button** to start data receive.
- Start the send operation on the sending machine. See the owner's manual that comes with the connected machine for details.
 - The keyboard automatically returns to its normal mode after all the data is received.

Troubleshooting

Problem	Possible Cause	Action	See page
No keyboard Sound	<ol style="list-style-type: none"> Power supply problem. Power is not turned on. Volume setting is too low. The MODE switch is in the CASIO CHORD or FINGERED position. LOCAL CONTROL is off. Mixer channel 1 is turned off. Mixer channel 1 volume or expression setting is too low. 	<ol style="list-style-type: none"> Correctly attach the AC adaptor, make sure that batteries poles (+/-) are facing correctly, and check to make sure that batteries are not dead. Press the POWER button to turn on power. Use the VOLUME slider to increase volume. Normal play is not possible on the accompaniment keyboard while the MODE switch is set to CASIO CHORD or FINGERED. Change the MODE switch setting to NORMAL. Turn on LOCAL CONTROL. Use the Mixer to turn channel 1 on. Use the Mixer to raise the volume or expression setting for channel 1. 	Page E-11 Page E-14 Page E-14 Page E-16 Page E-51 Page E-22 Pages E-23-24
Any of the following symptoms while using battery power. <ul style="list-style-type: none"> Dim power supply indicator Instrument does not turn on. Display that is flickering, dim, or difficult to read Abnormally low speaker/headphone volume Distortion of sound output Occasional interruption of sound when playing at high volumes Sudden power failure when playing at high volumes Flickering or dimming of the display when playing at high volume Continued sound output even after you release a key A totally different tone may sound Abnormal rhythm pattern and demo tune play Loss of power, sound distortion, or low volume when playing from a connected computer or MIDI device 	Low battery power	Replace the batteries with a set of new ones or use the AC adaptor.	Page E-11
Auto Accompaniment does not sound.	<ol style="list-style-type: none"> Accompaniment volume is set to 000. Auto Accompaniment part Channels 7 through 10 are turned off. Auto Accompaniment part Channels 7 through 10 volume or expression setting is too low. 	<ol style="list-style-type: none"> Use the ACCOMP VOLUME button to increase the volume. Use the Mixer to turn the channels on. Use the Mixer to raise the volume or expression setting for the applicable channel. 	Page E-21 Page E-22 Pages E-23-24
Sound output does not change when key pressure is varied.	Touch response is turned off.	Press the TOUCH RESPONSE button to turn it on.	Page E-46
Playing the keyboard sounds two tones.	Layer is turned on.	Press the LAYER button to turn off layering.	Page E-44
Different tones sound when keys in different keyboard ranges are pressed.	Split is turned on.	Press the SPLIT button to turn off split.	Page E-45
The key or tuning does not match when playing along with another MIDI machine.	The tuning or transpose parameter is set to a value other than 00.	Change the transpose or tuning parameter value to 00.	Page E-47
Parts suddenly drop out during memory playback.	The number of tones being played at the same time exceeds the keyboard's limitation.	Use the Mixer to turn unneeded channels off and decrease the number of parts being played.	Page E-22
Some parts do not play at all during memory playback.	<ol style="list-style-type: none"> Channels are turned off or some channel is set to solo. Volume or expression setting is too low. 	<ol style="list-style-type: none"> Use the Mixer to turn channels on. Use the Mixer to check the volume or expression setting. 	Page E-22 Pages E-23-24
Cannot record Auto Accompaniment or rhythm.	Track other than Track 1 is selected as the recording track.	Tracks 2 through 6 are melody tracks. Use the track select buttons to select Track 1.	Page E-33

Problem	Possible Cause	Action	See page
Nothing happens when the LAYER or SPLIT button is pressed.	<ol style="list-style-type: none"> One or more of the melody channels (2 through 4) is turned off. The volume or expression setting of one or more of the melody channels (2 through 4) is too low. The keyboard is in record standby. 	<ol style="list-style-type: none"> Use the Mixer to turn on Channels 2 through 4. Use the Mixer to raise the volume or expression setting of Channels 2 through 4. The LAYER and SPLIT buttons are disabled during recording and record standby. 	Page E-22 Pages E-23-24 Page E-33
No sound is produced when playing MIDI data from a computer.	<ol style="list-style-type: none"> MIDI cables are not connected properly. Channel is turned off, or volume or expression setting is too low. 	<ol style="list-style-type: none"> Connect MIDI cables properly. Use the Mixer to turn the channel on, or raise the volume or expression setting. 	Page E-48 Pages E-23-24
The bass notes of General MIDI data being played back by a computer are one octave too low.	GM MODE is turned off.	Turn on GM MODE.	Page E-50
Playing on the keyboard produces an unnatural sound when connected to a computer.	The computer's MIDI THRU function is turned on.	Turn off the MIDI THRU function on the computer or turn off LOCAL CONTROL on the keyboard.	Page E-51
Cannot record chord accompaniment data on a computer.	ACCOMP MIDI OUT is turned off.	Turn on ACCOMP MIDI OUT.	Page E-51

Specifications

Model:	CTK-651														
Keyboard:	61 standard-size keys, 5 octaves (with touch response on/off)														
Drum Pads:	6														
Tones:	200 (128 General MIDI, 32 synthesized, 8 drum, 32 user); with layer and split														
Rhythm Instrument Tones:	61														
Polyphony:	24 notes maximum (12 for certain tones)														
Digital Effects:	3 reverb types (HALL, STAGE, ROOM)														
Auto Accompaniment	Rhythm Patterns: 100 Tempo: Variable (216 steps, ♩ = 40 to 255) Chords: 3 fingering methods (CASIO CHORD, FINGERED, FULL RANGE CHORD) Rhythm Controller: START/STOP, INTRO, NORMAL/FILL-IN, VARIATION/FILL-IN, SYNCHRO/ENDING Accomp Volume: 0 to 127 (128 steps) One-touch Presets: Recalls settings for tone and tempo in accordance with rhythm.														
Memory Function	Songs: 2 Recording Tracks: 6 (2 through 6 are melody tracks) Recording Methods: Real-time, step Memory Capacity: Approximately 4,900 notes (total for two songs) Edit Function: Equipped														
Demo Tunes:	2 <table border="1" style="margin-left: 20px;"> <thead> <tr> <th>Tune Number</th> <th>Name</th> <th>Composer</th> <th>Play Time</th> </tr> </thead> <tbody> <tr> <td>0</td> <td>STRONG NEW DAY</td> <td>EDWARD ALSTROM</td> <td>1:45</td> </tr> <tr> <td>1</td> <td>NIGHT DREAMS</td> <td>TECH-NOTE INTERNATIONAL LTD.</td> <td>1:38</td> </tr> </tbody> </table>			Tune Number	Name	Composer	Play Time	0	STRONG NEW DAY	EDWARD ALSTROM	1:45	1	NIGHT DREAMS	TECH-NOTE INTERNATIONAL LTD.	1:38
Tune Number	Name	Composer	Play Time												
0	STRONG NEW DAY	EDWARD ALSTROM	1:45												
1	NIGHT DREAMS	TECH-NOTE INTERNATIONAL LTD.	1:38												
Synthesizer Function	Parameters: PCM set, amp envelope set, attack rate, release rate, pitch envelope set, pitch, level, touch sense, pan														
Registration Memory	Number of Setups: 32 (4 setups x 8 banks) Memory Contents: Tone, Rhythm, Tempo, Split on/off, Split point, Layer on/off, Mixer settings (Channels 1-4), Keyboard channel on/off (Channels 1-10), Reverb settings, Touch Response settings, Assignable jack setting, Transpose, Tuning, Pitch Bend range, Accompaniment volume setting														
Mixer Function	Channels: 16 Parameters: Program change number, volume, expression, pan, coarse tuning, fine tuning, on/off/solo														
MIDI:	16 multi-timbre receive, GM Level 1 standard														
Other Functions	Pitch Bend Range: 12 semitones upwards and downwards Transpose: 25 steps (-12 semitones to +12 semitones) Tuning: Variable (A4 = approximately 440Hz ±50 cents)														
Terminals	MIDI Terminals: IN, OUT Assignable Terminal: Standard jack (sustain, sostenuto, soft, rhythm start/stop) Headphone/Output Terminal: Stereo standard jack Output Impedance: 150Ω Output Voltage: 5.0V (RMS) MAX Power Supply Terminal: 9V DC														
Power Supply:	Batteries: Dual power supply system 6 D-size batteries Battery Life: Approximately 4 hours continuous operation on manganese batteries AC Adaptor: AD-5 Auto Power Off: Turns power off approximately six minutes after last key operation. Enabled under battery power only, can be disabled manually.														

Speaker Output:	2.5W + 2.5W
Power consumption:	9V = 7.7W
Dimensions:	96.0 x 37.6 x 15.2 cm (37 ¹³ / ₁₆ x 14 ¹³ / ₁₆ x 5 ¹⁵ / ₁₆ inch)
Weight:	Approximately 5.8 kg (12.8lbs) (without batteries)

Bienvenido...

¡A la familia feliz de propietarios satisfechos de los instrumentos musicales electrónicos CASIO!
Para aprovechar al máximo de todas las características y funciones del teclado, lea detalladamente este manual y téngalo a mano para referencias futuras.

¡Importante!

Cambie rápidamente las pilas o utilice el adaptador de CA siempre que observe cualquiera de los síntomas siguientes.

- Indicador de alimentación débil.
- El instrumento no se activa.
- Presentación que está parpadeando, oscura o difícil de leer.
- Volumen de altavoz/auricular anormalmente bajo.
- Salida de sonido distorsionada.
- Interrupción ocasional de sonido cuando se ejecuta en volúmenes altos.
- Falla de alimentación repentina cuando se ejecuta en volúmenes altos.
- Parpadeo u oscurecimiento de la presentación cuando se ejecuta en volúmenes altos.
- La salida de sonido continúa aun después de soltar una tecla.
- El sonido producido es diferente al sonido seleccionado.
- Ejecución anormal de melodía de demostración y patrón de ritmo.
- Pérdida de potencia, distorsión de sonido o volumen bajo cuando se ejecuta desde una computadora o dispositivo MIDI conectado.



CASIO ELECTRONICS CO., LTD.
Unit 6, 1000
North Circular Road
London NW2 7JD, U.K.

Esta marca es válida solamente en los países de la UE.
Guarde toda información para referencia futura.

Fuente de alimentación:	Sistema de alimentación doble.
Pilas:	6 pilas de tamaño D.
Duración de pila:	Aproximadamente 4 horas de operación continua con pilas de manganeso.
Adaptador de CA:	AD-5.
Apagado automático:	Desactiva automáticamente en aproximadamente seis minutos después de la última operación de tecla. Solamente puede usarse cuando se utiliza la alimentación mediante pilas, puede inhabilitarse manualmente.
Salida de altavoces:	2,5W + 2,5W.
Consumo de energía:	9V = 7,7W.
Dimensiones:	96,0 x 37,6 x 15,2 cm.
Peso:	Aproximadamente 5,8 kg (sin pilas).

Note Table
Tabla de notas

000 24 1 A A0-C8	010 12 2 A C4-C6	020 24 1 A C2-C7	030 24 1 A E2-D6	(1) (2) (3) (4) (5)
001 24 1 A A0-C8	011 12 2 A F3-F6	021 12 2 A F3-F6	031 24 1 A E2-D6	(1) (2) (3) (4) (5)
002 12 2 A A0-C8	012 24 1 A C3-C6	022 24 1 A C4-C7	032 24 1 B E1-G3	(1) (2) (3) (4) (5)
003 12 2 A A0-C8	013 24 1 A F4-C7	023 12 2 A F3-F6	033 24 1 B E1-G3	(1) (2) (3) (4) (5)
004 24 1 A E1-G7	014 24 1 A C4-C6	024 24 1 A E2-C6	034 24 1 B E1-G3	(1) (2) (3) (4) (5)
005 24 1 A E1-G7	015 12 2 A C2-C7	025 24 1 A E2-C6	035 24 1 B E1-G3	(1) (2) (3) (4) (5)
006 24 1 A E1-G7	016 12 2 A C2-C7	026 24 1 A E2-D6	036 24 1 B E1-G3	(1) (2) (3) (4) (5)
007 24 1 A C4-C8	017 12 2 A C2-C7	027 24 1 A E2-D6	037 24 1 B E1-G3	(1) (2) (3) (4) (5)
008 24 1 A C4-C8	018 12 2 A A0-C8	028 24 1 A E2-D6	038 24 1 B E1-G3	(1) (2) (3) (4) (5)
009 24 1 A C5-C8	019 12 2 A A0-C8	029 24 1 A E2-D6	039 24 1 B E1-G3	(1) (2) (3) (4) (5)
(1) (2) (3) (4) (5)	040 24 1 A G3-C7	(1) (2) (3) (4) (5)	070 24 1 B A1-C5	(1) (2) (3) (4) (5)
041 12 2 A C3-C7	041 12 2 A C2-C7	060 12 2 A F2-F5	071 24 1 A D3-G6	(1) (2) (3) (4) (5)
042 24 1 A C2-C5	042 24 1 A C3-G5	061 24 1 A C2-C7	072 24 1 C D5-C8	(1) (2) (3) (4) (5)
043 24 1 B E1-G3	043 24 1 A C3-G5	062 12 2 A C2-C7	073 24 1 A C4-C7	(1) (2) (3) (4) (5)
044 24 1 A E1-C7	044 12 2 A C3-G5	063 12 2 A C2-C7	074 24 1 A C4-C7	(1) (2) (3) (4) (5)
045 24 1 A E1-C7	045 12 2 A C3-C5	064 24 1 A F3-D6	075 24 1 A C4-C7	(1) (2) (3) (4) (5)
046 24 1 A B0-G7	046 24 1 A C3-C5	065 24 1 A C3-G5	076 12 2 A G3-C6	(1) (2) (3) (4) (5)
047 24 1 A B2-A3	047 24 1 A A1-D6	066 24 1 A F2-D6	077 24 1 A C4-C7	(1) (2) (3) (4) (5)
048 24 1 A E1-C7	048 24 1 A A3-A5	067 24 1 B C2-G4	078 24 1 A C4-C7	(1) (2) (3) (4) (5)
(1) (2) (3) (4) (5)	049 24 1 A E1-C7	068 24 1 A A3-A5	079 24 1 A C4-C6	(1) (2) (3) (4) (5)
080 12 2 A A0-C8	(1) (2) (3) (4) (5)	(1) (2) (3) (4) (5)	110 12 2 A G3-C7	(1) (2) (3) (4) (5)
081 12 2 A A0-C8	080 12 2 A C2-C7	100 12 2 A C2-C7	111 24 1 A C5-C8	(1) (2) (3) (4) (5)
082 12 2 A A0-C8	081 12 2 A C2-C7	101 12 2 A C2-C7	112 24 1 A C5-C6	(1) (2) (3) (4) (5)
083 12 2 A C2-C7	082 12 2 A C2-C7	102 12 2 A C2-C7	113 24 1 A C4-C5	(1) (2) (3) (4) (5)
084 12 2 A C2-C7	083 12 2 A C2-C7	103 12 2 A C2-C7	114 12 2 A E3-E5	(1) (2) (3) (4) (5)
085 12 2 A C2-C7	084 12 2 A C2-C7	104 24 1 A C3-F5	115 24 1 D C4-C5	(1) (2) (3) (4) (5)
086 12 2 A C2-C7	085 12 2 A C2-C7	105 24 1 A C3-C6	116 24 1 D C4-C5	(1) (2) (3) (4) (5)
087 12 2 A A0-C8	086 12 2 A C2-C7	106 24 1 A D3-G5	117 24 1 D C4-C5	(1) (2) (3) (4) (5)
088 12 2 A C2-C7	087 12 2 A C2-C7	107 24 1 A C3-C6	118 12 2 D C4-C5	(1) (2) (3) (4) (5)
089 24 1 A C2-C7	088 12 2 A C2-C7	108 24 1 A C3-G6	119 24 1 D C4-C5	(1) (2) (3) (4) (5)
(1) (2) (3) (4) (5)	089 12 2 A C2-C7	109 12 2 A C2-F5		

- (1): Tone number/Número de sonido
 - (2): Maximum polyphony/Polifonía máxima
 - (3): Number of DCOs used (page E-26)/Número de DCO usados (página S-26)
 - (4): Range type /Tipo de gama
 - (5): Recommended sound range for General MIDI
- *The following shows maximum polyphony for synthesized tones 128 through 159.
 141 BASS SLIDE: 24 notes, 1 DCO
 Other tones: 12 notes, 2 DCO
 Lo siguiente muestra la polifonía máxima para los sonidos sintetizados 128 al 159.
 141 BASS SLIDE: 24 notas, 1 DCO
 Otros tonos: 12 notas, 2 DCO

Appendix/Apéndice

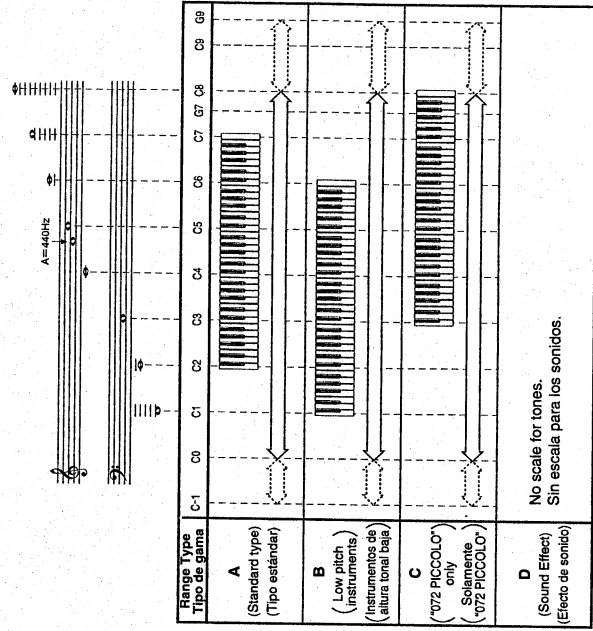

- Range Type / Tipo de gama
- Playable range (Transposition, when receiving MIDI data) / Gama ejecutable (Transposición, al recibir datos MIDI)
- Range in which same note is played in nearest octave as a result of transpose and MIDI data receive operation. / Gama en la que la misma nota se ejecuta en la octava más cercana como un resultado de la transposición y operación de recepción de datos MIDI.

**Drum Assignment List (← Indicates the same sound as STANDARD SET)
 Lista de asignación de batería (← Indica el mismo sonido que STANDARD SET)**

Key/Note number	Drumset 1 STANDARD SET	Drumset 2 ROOM SET	Drumset 3 POWER SET	Drumset 4 VOICE SET	Drumset 5 SYNTH SET	Drumset 6 JAZZ SET	Drumset 7 BRUSH SET	Drumset 8 ORCHESTRAL SET
E1 27	HIGH C							CLOSED HI-HAT
E1 28	METRONOME BELL							OPEN HI-HAT
F1 29	SCRATCH PUSH							RISE CYMBAL 1
F1 30	SCRATCH PULL							
G1 31	STICKS							
A1 32	SQUARE CLICK							
A1 33	METRONOME CLICK							
B1 34	METRONOME BELL							
B1 35	POWER BASS DRUM 2	POWER BASS DRUM 2	POWER BASS DRUM 2	POWER BASS DRUM 2	POWER BASS DRUM 2	POWER BASS DRUM 2	POWER BASS DRUM 2	JAZZ BASS DRUM 1
B1 36	POWER BASS DRUM 3	POWER BASS DRUM 3	POWER BASS DRUM 3	POWER BASS DRUM 3	POWER BASS DRUM 3	POWER BASS DRUM 3	POWER BASS DRUM 3	JAZZ BASS DRUM 2
C2 37	ADJUST STICK	ROOM SNARE 1	ROOM SNARE 1	ROOM SNARE 1	ROOM SNARE 1	ROOM SNARE 1	ROOM SNARE 1	CONCERT SNARE
C2 38	ADJUST STICK	ROOM SNARE 1	ROOM SNARE 1	ROOM SNARE 1	ROOM SNARE 1	ROOM SNARE 1	ROOM SNARE 1	CONCERT SNARE
E2 39	HAND CLAP	ROOM SNARE 2	ROOM SNARE 2	ROOM SNARE 2	ROOM SNARE 2	ROOM SNARE 2	ROOM SNARE 2	CONCERT SNARE
E2 40	ACUSTIC SNARE 2	ROOM SNARE 2	ROOM SNARE 2	ROOM SNARE 2	ROOM SNARE 2	ROOM SNARE 2	ROOM SNARE 2	CONCERT SNARE
F2 41	LOW FLOOR TOM	ROOM LOW FLOOR TOM	ROOM LOW FLOOR TOM	ROOM LOW FLOOR TOM	ROOM LOW FLOOR TOM	ROOM LOW FLOOR TOM	ROOM LOW FLOOR TOM	CONCERT SNARE
F2 42	LOW FLOOR TOM	ROOM LOW FLOOR TOM	ROOM LOW FLOOR TOM	ROOM LOW FLOOR TOM	ROOM LOW FLOOR TOM	ROOM LOW FLOOR TOM	ROOM LOW FLOOR TOM	CONCERT SNARE
G2 43	HIGH FLOOR TOM	ROOM HIGH FLOOR TOM	ROOM HIGH FLOOR TOM	ROOM HIGH FLOOR TOM	ROOM HIGH FLOOR TOM	ROOM HIGH FLOOR TOM	ROOM HIGH FLOOR TOM	CONCERT SNARE
G2 44	HIGH FLOOR TOM	ROOM HIGH FLOOR TOM	ROOM HIGH FLOOR TOM	ROOM HIGH FLOOR TOM	ROOM HIGH FLOOR TOM	ROOM HIGH FLOOR TOM	ROOM HIGH FLOOR TOM	CONCERT SNARE
A2 45	PEDAL HI-HAT	ROOM LOW TOM	ROOM LOW TOM	ROOM LOW TOM	ROOM LOW TOM	ROOM LOW TOM	ROOM LOW TOM	CONCERT SNARE
B2 46	OPEN HI-HAT	ROOM LOW MID TOM	ROOM LOW MID TOM	ROOM LOW MID TOM	ROOM LOW MID TOM	ROOM LOW MID TOM	ROOM LOW MID TOM	CONCERT SNARE
B2 47	OPEN HI-HAT	ROOM LOW MID TOM	ROOM LOW MID TOM	ROOM LOW MID TOM	ROOM LOW MID TOM	ROOM LOW MID TOM	ROOM LOW MID TOM	CONCERT SNARE
C3 48	HIGH TOM	ROOM HIGH MID TOM	ROOM HIGH MID TOM	ROOM HIGH MID TOM	ROOM HIGH MID TOM	ROOM HIGH MID TOM	ROOM HIGH MID TOM	CONCERT SNARE
C3 49	HIGH TOM	ROOM HIGH MID TOM	ROOM HIGH MID TOM	ROOM HIGH MID TOM	ROOM HIGH MID TOM	ROOM HIGH MID TOM	ROOM HIGH MID TOM	CONCERT SNARE
D3 50	HIGH TOM	ROOM HIGH TOM	ROOM HIGH TOM	ROOM HIGH TOM	ROOM HIGH TOM	ROOM HIGH TOM	ROOM HIGH TOM	CONCERT SNARE
D3 51	HIGH TOM	ROOM HIGH TOM	ROOM HIGH TOM	ROOM HIGH TOM	ROOM HIGH TOM	ROOM HIGH TOM	ROOM HIGH TOM	CONCERT SNARE
E3 52	CHINESE CYMBAL							CONCERT CYMBAL 1
F3 53	CHINESE CYMBAL							CONCERT CYMBAL 1
F3 54	TAMBOURINE							CONCERT CYMBAL 1
G3 55	CHINESE CYMBAL							CONCERT CYMBAL 1
A3 56	CHINESE CYMBAL							CONCERT CYMBAL 1
A3 57	CRASH CYMBAL 2							CONCERT CYMBAL 1
B3 58	VIBRA-SLAP							CONCERT CYMBAL 1
B3 59	RISE CYMBAL 2							CONCERT CYMBAL 1
C4 60	HIGH BONGO							CONCERT CYMBAL 1
C4 61	LOW BONGO							CONCERT CYMBAL 1
D4 62	LOW CONGA							CONCERT CYMBAL 1
E4 63	OPEN HIGH CONGA							CONCERT CYMBAL 1
E4 64	LOW CONGA							CONCERT CYMBAL 1
F4 65	HIGH TIMBALES							CONCERT CYMBAL 1
F4 66	LOW TIMBALES							CONCERT CYMBAL 1
G4 67	HIGH AGOGO							CONCERT CYMBAL 1
A4 68	LOW AGOGO							CONCERT CYMBAL 1
A4 69	MARACAS							CONCERT CYMBAL 1
B4 70	MARACAS							CONCERT CYMBAL 1
C5 71	SHORT WHISTLE							CONCERT CYMBAL 1
C5 72	LONG WHISTLE							CONCERT CYMBAL 1
D5 73	SHORT GUIRO							CONCERT CYMBAL 1
D5 74	LONG GUIRO							CONCERT CYMBAL 1
E5 75	CLAVES							CONCERT CYMBAL 1
F5 76	CLAVES							CONCERT CYMBAL 1
F5 77	CLAVES							CONCERT CYMBAL 1
G5 78	CLAVES							CONCERT CYMBAL 1
A5 79	MUTE QUIKA							CONCERT CYMBAL 1
A5 80	MUTE TRIANGLE							CONCERT CYMBAL 1
B5 81	OPEN TRIANGLE							CONCERT CYMBAL 1
B5 82	SHAKER BELL							CONCERT CYMBAL 1
C6 83	BELL TREE							CONCERT CYMBAL 1
C6 84	GASTANETS							CONCERT CYMBAL 1
D6 85	MUTE SURDO							CONCERT CYMBAL 1
D6 86	MUTE SURDO							CONCERT CYMBAL 1
E6 87	OPEN SURDO							CONCERT CYMBAL 1
E6 88								CONCERT CYMBAL 1
E6 89								CONCERT CYMBAL 1
E6 90								CONCERT CYMBAL 1
E6 91								CONCERT CYMBAL 1
E6 92								CONCERT CYMBAL 1
E6 93								CONCERT CYMBAL 1
E6 94								CONCERT CYMBAL 1
E6 95								CONCERT CYMBAL 1
E6 96								CONCERT CYMBAL 1
E6 97								CONCERT CYMBAL 1
E6 98								CONCERT CYMBAL 1
E6 99								CONCERT CYMBAL 1
E6 100								CONCERT CYMBAL 1
E6 101								CONCERT CYMBAL 1
E6 102								CONCERT CYMBAL 1
E6 103								CONCERT CYMBAL 1
E6 104								CONCERT CYMBAL 1
E6 105								CONCERT CYMBAL 1
E6 106								CONCERT CYMBAL 1
E6 107								CONCERT CYMBAL 1
E6 108								CONCERT CYMBAL 1
E6 109								CONCERT CYMBAL 1
E6 110								CONCERT CYMBAL 1
E6 111								CONCERT CYMBAL 1
E6 112								CONCERT CYMBAL 1
E6 113								CONCERT CYMBAL 1
E6 114								CONCERT CYMBAL 1
E6 115								CONCERT CYMBAL 1
E6 116								CONCERT CYMBAL 1
E6 117								CONCERT CYMBAL 1
E6 118								CONCERT CYMBAL 1
E6 119								CONCERT CYMBAL 1
E6 120								CONCERT CYMBAL 1
E6 121								CONCERT CYMBAL 1
E6 122								CONCERT CYMBAL 1
E6 123								CONCERT CYMBAL 1
E6 124								CONCERT CYMBAL 1
E6 125								CONCERT CYMBAL 1
E6 126								CONCERT CYMBAL 1
E6 127								CONCERT CYMBAL 1
E6 128								CONCERT CYMBAL 1
E6 129								CONCERT CYMBAL 1
E6 130								CONCERT CYMBAL 1
E6 131								CONCERT CYMBAL 1
E6 132								CONCERT CYMBAL 1
E6 133								CONCERT CYMBAL 1
E6 134								CONCERT CYMBAL 1
E6 135								CONCERT CYMBAL 1
E6 136								CONCERT CYMBAL 1
E6 137								CONCERT CYMBAL 1
E6 138								CONCERT CYMBAL 1
E6 139								CONCERT CYMBAL 1
E6 140								CONCERT CYMBAL 1
E6 141								CONCERT CYMBAL 1
E6 142								CONCERT CYMBAL 1
E6 143								CONCERT CYMBAL 1
E6 144								CONCERT CYMBAL 1
E6 145								CONCERT CYMBAL 1
E6 146								CONCERT CYMBAL 1
E6 147								CONCERT CYMBAL 1
E6 148								CONCERT CYMBAL 1
E6 149								CONCERT CYMBAL 1
E6 150								CONCERT CYMBAL 1
E6 151								CONCERT CYMBAL 1
E6 152								CONCERT CYMBAL 1
E6 153								CONCERT CYMBAL 1
E6 154								CONCERT CYMBAL 1
E6 155								CONCERT CYMBAL 1
E6 156								CONCERT CYMBAL 1
E6 157								CONCERT CYMBAL 1
E6 158								CONCERT CYMBAL 1
E6 159								CONCERT CYMBAL 1
E6 160								CONCERT CYMBAL 1
E6 161								CONCERT CYMBAL 1
E6 162								CONCERT CYMBAL 1
E6 163								CONCERT CYMBAL 1
E6 164								CONCERT CYMBAL 1
E6 165								CONCERT CYMBAL 1
E6 166								CONCERT CYMBAL 1
E6 167								CONCERT CYMBAL 1
E6 168								CONCERT CYMBAL 1
E6 169								CONCERT CYMBAL 1
E6 170								CONCERT CYMBAL 1
E6 171								CONCERT CYMBAL 1
E6 172								CONCERT CYMBAL 1
E6 173								CONCERT CYMBAL 1
E6 174								CONCERT CYMBAL 1
E6 175								CONCERT CYMBAL 1
E6 176								CONCERT CYMBAL 1
E6 177								CONCERT CYMBAL 1
E6 178								CONCERT CYMBAL 1
E6 179								CONCERT CYMBAL 1
E6 180								CONCERT CYMBAL 1
E6 181								CONCERT CYMBAL 1
E6 182								CONCERT CYMBAL 1
E6 183								CONCERT CYMBAL 1
E6 184								CONCERT CYMBAL 1
E6 185								CONCERT CYMBAL 1
E6 186								CONCERT CYMBAL 1
E6 187								CONCERT CYMBAL 1
E6 188								CONCERT CYMBAL 1
E6 189								CONCERT CYMBAL 1
E6 190								CONCERT CYMBAL 1
E6 191								CONCERT CYMBAL 1
E6 192								CONCERT CYMBAL 1
E6 193								CONCERT CYMBAL 1
E6 194								CONCERT CYMBAL 1
E6 195								CONCERT CYMBAL 1
E6 196								CONCERT CYMBAL 1
E6 197								CONCERT CYMBAL 1
E6 198								CONCERT CYMBAL 1
E6 199								CONCERT CYMBAL 1
E6 200								CONCERT CYMBAL 1
E6 201								CONCERT CYMBAL 1
E6 202								CONCERT CYMBAL 1
E6 203								CONCERT CYMBAL 1
E6 204								CONCERT CYMBAL 1
E6 205								CONCERT CYMBAL 1
E6 206								CONCERT CYMBAL 1
E6 207								CONCERT CYMBAL 1
E6 208								CONCERT CYMBAL 1
E6 209								CONCERT CYMBAL 1
E6 210								CONCERT CYMBAL 1
E6 211								CONCERT CYMBAL 1
E6 212								CONCERT CYMBAL 1
E6 213								CONCERT CYMBAL 1
E6 214								CONCERT CYMBAL 1
E6 215								CONCERT CYMBAL 1
E6 216								CONCERT CYMBAL 1
E6 217								CONCERT CYMBAL 1
E6 218								CONCERT CYMBAL 1
E6 219								CONCERT CYMBAL 1
E6 220								CONCERT CYMBAL 1
E6 221								CONCERT CYMBAL 1
E6 222								CONCERT CYMBAL 1
E6 223								CONCERT CYMBAL 1
E6 224								CONCERT CYMBAL 1
E6 225								CONCERT CYMBAL 1
E6 226								CONCERT CYMBAL 1
E6 227								CONCERT CYMBAL 1
E6 228								CONCERT CYMBAL 1
E6 229								CONCERT CYMBAL 1
E6 230								CONCERT CYMBAL 1
E6 231								CONCERT CYMBAL 1
E6 232								CONCERT CYMBAL 1
E6 233								CONCERT CYMBAL 1
E6 234			</					

This file has been downloaded from:

www.UsersManualGuide.com

User Manual and User Guide for many equipments like mobile phones, photo cameras, mother board, monitors, software, tv, dvd, and othes..

Manual users, user manuals, user guide manual, owners manual, instruction manual, manual owner, manual owner's, manual guide, manual operation, operating manual, user's manual, operating instructions, manual operators, manual operator, manual product, documentation manual, user maintenance, brochure, user reference, pdf manual