

OPERATING INSTRUCTIONS AND PARTS LIST FOR

JIG SAW

24 INCH

Model Number 103.23440

This is the model number of your Jig Saw. It will be found on a plate located on the back of the base. Always mention this model number when communicating with us regarding your Jig Saw or when ordering parts.

Instructions for Ordering Parts

All parts listed herein must be ordered through a Sears retail store or mail order house. Parts are shipped pre-paid. When ordering repair parts, always give the following information:

1. The Part Number.
2. The Part Name and Price.
3. The Model Number 103.23440.

This list is valuable. It will assure your being able to obtain proper parts service. We suggest you keep it with other valuable papers.

SEARS, ROEBUCK and CO.

LITHOGRAPHED IN U. S. A.

OPERATING INSTRUCTIONS AND PARTS LIST FOR JIG SAW

MODEL NUMBER 103.23440

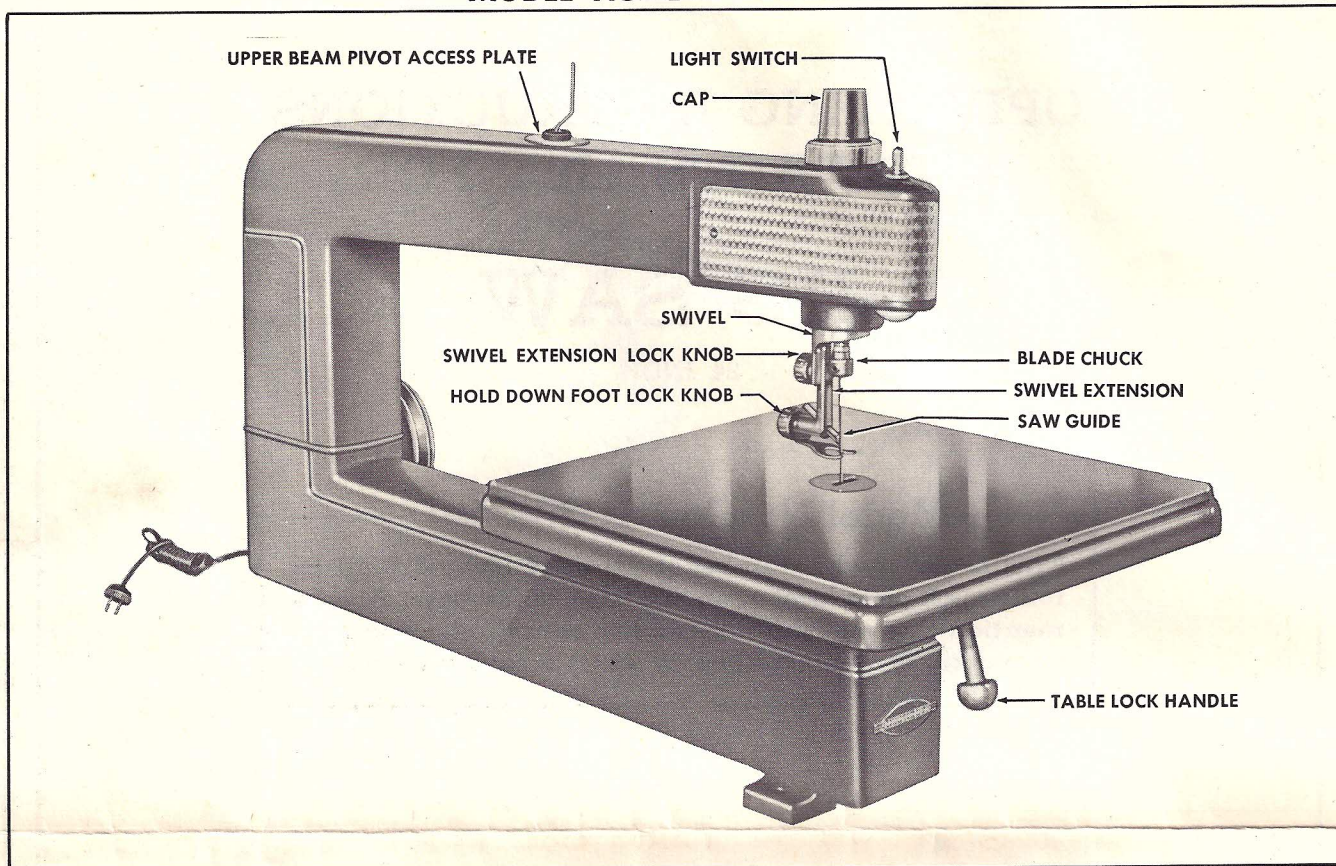

FIGURE 1

This Jig Saw has been completely inspected and tested at the factory. To avoid breakage and misalignment of parts during shipment, the table and several miscellaneous parts have been packed disassembled. Be sure that all parts are removed from the crate before discarding it.

REASSEMBLING:

The tool may be reassembled as follows:

1. Place the front trunnion 23426 against the front of the trunnion support 23412 so that the groove in the trunnion fits over the ridge on the support as shown in figure 2.
2. Place the square head bolt, X-307 through the hole in the front of the support from the inside of the support, and through the cut-out in the trunnion. Place the flat washer X-601 over the exposed end of the bolt.
3. Insert the acorn head trunnion nut 23641 through the handle 23419 and turn the nut onto the shank of the bolt. Tighten the nut with the trunnion in a level position.
4. Remove the saw blade—loosen the socket head set screws 18518 in the upper and lower chucks to free the blade. The wrench 23646 will fit the socket head set screws mentioned.
5. Place the table in position so that the rear trunnion and the support fit as shown in figure 2. Line the holes up in the table and front trun-

nion, and install the two fillister head screws and lock washers to secure the table to the front trunnion.

6. Place the table insert 18126 in the counter-bored hole at the center of the top surface of the table with the slot running parallel to the front edge of the table as shown in figure 1.
7. Insert the blade in both chucks with the teeth pointing down and forward. Clamp the blade firmly in the lower chuck first by tightening the socket head set screw with the wrench 23646 provided. The "walking beam" type action incorporated in this saw provides pulling action from the top on the upstroke, and from the bottom on the downstroke, thus eliminating the necessity of applying great preloading pressures on the blade as with spring loaded models. To apply the necessary tension, after clamping the blade in the lower chuck, pull the chucks down to the bottom of the stroke, hold the upper chuck down firmly while you tighten the socket head set screw.
8. Install the upper saw guide assembly by loosening the swivel extension lock knob (figure 1) until the swivel extension 23416 will slide under the head of the swivel extension bolt 23612.
9. Place the access plates in their respective holes as shown in figure 1. The wrench 23646 may be kept in the rubber grommet of the upper access plate when not in use.

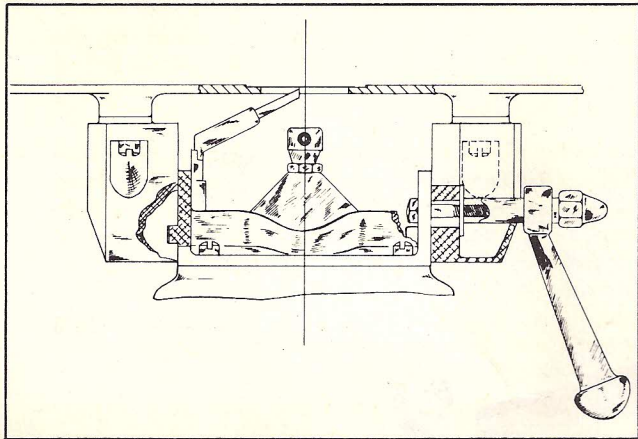

FIGURE 2

LUBRICATION:

The special 2 row ball bearing used on the drive spindle has been packed with lubricant and sealed at the factory. It should require no further attention for the life of the bearing.

NOTE: If replacement of this bearing is necessary for any reason, full instructions covering removal of the old bearing and installation of the new one will be supplied with the replacement part.

To maintain smooth operation, apply a drop of oil occasionally to the trunnions in which the table pivots.

INSTALLATION:

It is recommended that the Jig Saw be mounted securely to a well constructed work bench with screws or bolts. Three 7/16 inch diameter holes are provided in the base for mounting this Jig Saw on your bench. The motor may be installed below or behind the tool. The pulley on the tool is designed to use a standard 1/2 inch V belt. The length of belt necessary may be determined after the motor position has been established, by measuring with a piece of string or flexible tape around the outside diameters, not in the groove, of the pulleys.

SPEED:

This Jig Saw will operate most efficiently at 525 and 1010 R.P.M. The speed used should be determined by the kind of material and the thickness of material to be cut. The thicker, or harder the material, the slower the speed.

Sufficient power and speed may be attained by using not less than a 1/4 horsepower 1750 R.P.M. motor. For continuous or heavy duty work a 1/3 horsepower 1750 R.P.M. should be used. The motor should be equipped with two pulleys, a 2-inch and a 3-inch diameter hubless 1/2 inch V pulley.

The following table shows the speeds which result when the two different recommended pulley combinations are used.

Jig Saw Pulley Step Diameter	Motor Pulley Diameter	Resulting R.P.M.
6"	2"	525
5"	3"	1010

When ordering the hubless V pulleys mentioned, be sure to specify the shaft diameter of your motor.

CONTROLS:

The table lock handle when engaged on the hexagon

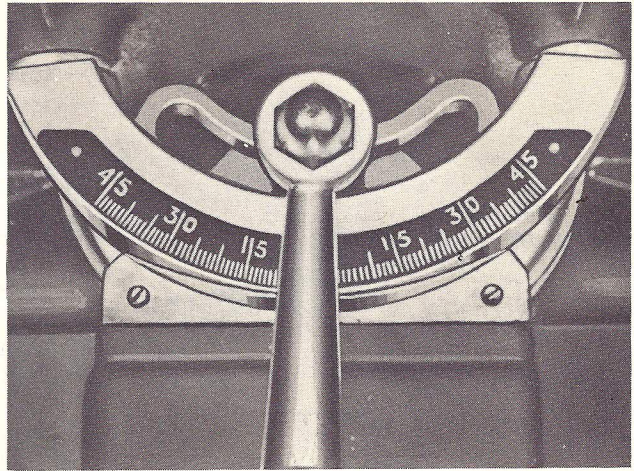

FIGURE 3

head of the trunnion nut may be used to release the table for tilting or to lock it in position after the angle of cut has been selected.

The angle of cut is shown on a calibrated scale attached to the front trunnion. The pointer indicates the degree of tilt and the resulting angle of cut. When installed in normal position, the table may be tilted 45° to the right or to the left.

The upper and lower saw guides 23512 are plastic rods incorporated to support the saw blade against the thrust action of the work piece.

The face of each guide has been slotted to aid in maintaining the vertical alignment of the blade by counteracting any side thrust that might be applied as the work piece is pushed against the blade.

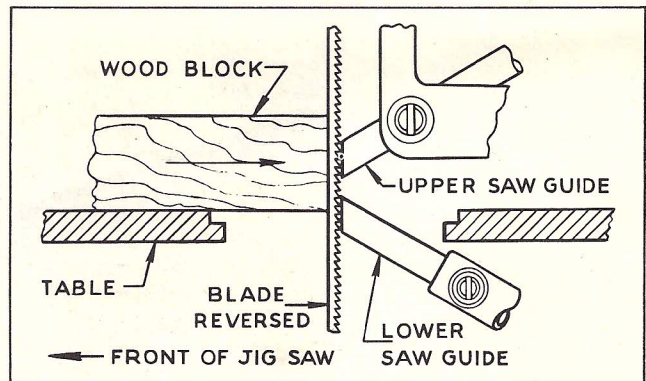

FIGURE 4

If in the future your present saw guides should require refacing or if new guides are installed, the faces should be slotted as follows: See figure 4.

1. Reverse the blade so that the teeth point to the rear of the saw and down.
2. Lock each guide in position so that its face touches the blade teeth lightly.
3. Start the saw and push the blade lightly with a wood block as shown in figure 4 until a cut approximately 1/32 inch deep has been made in the face of each guide.
4. Return the blade to its normal position, teeth pointing down and forward and set the guides so that the smooth edge of the blade will ride in the recess just cut in the face of each. Do not force the guides against the blade causing misalignment.

The hold down foot 23712, is a spring steel stamping secured to the swivel extension. The foot should contact the work lightly, thus holding the work against the table and preventing the work from following the blade on upstroke.

The swivel extension allows the hold-down foot and upper saw guide to be raised or lowered to accommodate the various thicknesses of material. The extension is locked in position by the swivel extension lock knob (figure 1).

The swivel may be rotated in place after the cap (figure 1) has been loosened. After the swivel position has been selected, clamp it securely in place by tightening the cap.

For ripping pieces longer than 24 inches, the chucks and swivel may be rotated 90 degrees. However, if an angle cut is desired when ripping the long piece, the table and table support assembly must be rotated. This may be accomplished by removing the four screws holding the table support to the base, rotating the whole table and support assembly 90° and reinstalling the four bolts. To turn the chuck 90°, insert the wrench 23646 into the socket head set screw in the chuck and hold the chuck in position while you loosen the ferrule nut 23626. The wrench in the chuck set screw will prevent twisting the pull rod as the ferrule nut is turned. Rotate the swivel 90° so that the upper saw guide is in proper position. The table insert must also be rotated 90° to prevent interference with the blade when the table is tilted.

CHUCK:

When clamping the blade in the chuck always use the socket head set screw 18518. The slotted head set screw 18519 is to be used only as an adjusting screw to center the blade in the chuck and should be turned only after the socket head screw has been loosened. The slotted head screw has a serrated face designed for gripping and holding the blade. This screw, if turned to apply pressure will score the blade causing breakage.

The centering cover 18917 automatically centers the regular saw blades. If blades of greater width are used, the cover may be slipped off after removing the set screws from the chuck body. This allows insertion of wide blades in chuck. The shoe—18938 installed between the socket head set screw and the blade, provides maximum grip of the blade.

ADJUSTMENT:

The blade requires only enough tension to keep it in a straight line during normal operation. If the blade should become sloppy and bend too easily when the work piece is fed against it, be sure first that the blade is not dull. If the blade is sharp, further tension should be applied by the method described in the paragraph "Reassembling." The use of a good sharp blade, and the proper position of the upper and lower guides will minimize tension difficulties.

The design of this saw allows use of a variety of blade lengths over 6 inches. The extra length can extend through the chuck and into the hollow pull rods to which the chucks are attached. To obtain maximum benefit from the longer blades, they should be reset occasionally, raising or lowering the blade 1¼ inches in the chucks to provide an entire new cutting surface.

If the table is not square with the blade, the resulting cut will not be square. The squareness of the blade and table may be checked and corrected if necessary by resetting the table or by recentering the blade in the chucks.

Check the blade by holding a pencil on the table with the point touching the flat side of the blade. Turn the pulley slowly by hand. If the blade is properly centered, it will remain in contact with the pencil point through the entire stroke without moving the pencil or deflecting the blade. If the pencil test shows that the blade is not running in a true vertical line, adjustment may be made by recentering the blade in the chucks as previously described.

After making the pencil test and necessary adjustments if the cut is still not square when the pointer shows 0 degrees on the protractor scale, set the table perpendicular to the blade and reset the pointer at 0 degrees by loosening the two screws which hold it to the tool.

Re-tighten pulley set screws after a few hours operation.

OPERATION:

This tool was designed to be the best possible Jig Saw and for this reason it is not recommended for use as a filing machine.

Do not use excessive force when feeding material to the blade. This not only causes excessive blade breakage but makes it more difficult to follow a planned line. A smooth steady feed which does not overtax the cutting capacity of the blade will always give a smoother more easily controlled cut.

Feed the material directly into the blade. Avoid side thrust—this causes an irregular cut and increases the frequency of blade breakage.

Inside, or included holes may be cut by drilling through the waste area of the work piece with a drill larger than the blade width. Remove the blade and reinstall it as previously instructed, passing it through the hole in the work piece. If continuous cutting of internal holes is planned, a saber blade may be used in the lower chuck to allow setting the work piece over the end of the blade rather than to remove the blade after each operation. The saber blade should project slightly above the top surface of the work piece when the chuck is at the bottom of the stroke. Install the blade with the teeth pointing down, and be sure that the lower saw guide is set close to support the blade against the thrust of the work piece. To insure square edges, hold the work piece firmly against the table surface during cutting operations.

An air pump has been incorporated which delivers a blast of air through the upper chuck to keep the area around the blade clear of the saw dust so that the pattern lines on the work piece will remain clearly visible. To insure maximum efficiency of this air jet, the cap (figure 1) must be tight at all times.

SAFETY:

Due to the variety of possible installations a pulley guard is not furnished for this machine. However, it is advisable that suitable protection be provided so that clothing does not become entangled in the turning pulley.

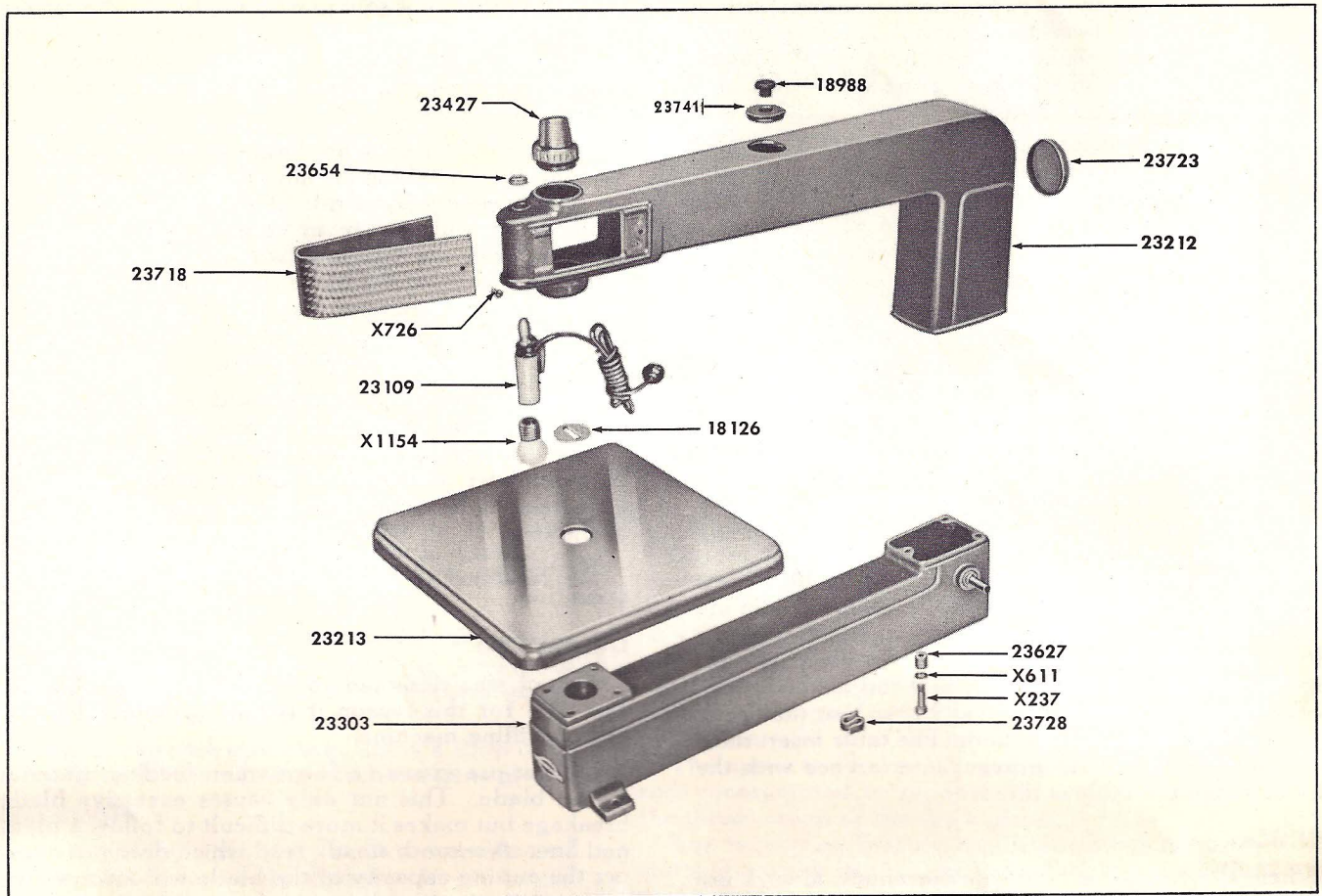

PARTS LIST

Part No.	NAME OF PART	Prepaid Selling Price (Each)	Part No.	NAME OF PART	Prepaid Selling Price (Each)
18126	Table Insert	.20	23652	Connecting Rod (Long)	.50
18518	Chuck Set Screw—Socket Head	.25	23653	Pin	.15
18519	Chuck Adj. Screw—Slotted Head	.15	23654	Light Switch Retaining Nut	.30
18619	Clamp Knob	.45	23712	Hold Down Foot	.15
18917	Blade Centering Cover	.25	23713	Pointer	.20
18938	Chuck Shoe	.20	23717	Washer—Countersunk	.15
18988	Rubber Grommet	.20	23718	Panel	1.60
23102	Blade Chuck Ass'y Complete	.90	23723	Rear Access Plate	.25
23109	Lamp Ass'y	3.00	23728	Light Cord Clip	.15
23120	Cage with Bushings	2.75	23729	Preloading Spring	.15
23130	Lower Beam	1.75	23737	Washer	.15
23160	Eccentric Housing with Bushing	.60	23738	Rocker Beam Washer	.15
23201	Upper Beam	2.25	23739	Alignment Washer	.15
23212	Arm	23.00	23741	Upper Access Plate	.25
23213	Table	20.50	23813	Protractor Scale	.25
23270	Drive Shaft with Bearing	4.25	23816	Beam Pivot Grommet	.15
23290	Eccentric with Set Screws	2.25	23817	Beam End Grommet	.15
23303	Base with Bearing Installed	30.00	23818	Rocker Beam Pad	.15
23304	Pulley with Set Screws	2.85	23825	Fibre Washer	.15
23412	Trunnion Support	2.15	23831	Dust Shield	.40
23413	Rear Trunnion	1.65	23832	Dust Shield Retaining Spring	.20
23415	Swivel	1.50	23833	Leather Washer	.15
23416	Swivel Extension	1.00	X-100	Set Screw ¼—20 x ¼ Slotted Head Cup Point	.10
23417	Saw Guide Holder	.35	X-109	Set Screw No. 10—24 x ¼ Slotted Head Cup Point	.10
23419	Table Lock Handle	1.75	X-174	Set Screw 5/16—18 x ¾ Socket Head Cup Point	.10
23426	Front Trunnion	2.10	X-237	Cap Screw 5/16—18 x 1¼ Socket Head	.10
23427	Cap	2.00	*X-307	Machine Bolt 5/16—18 x 1½ Square Head	.10
23512	Saw Guide	.35	X-490	Self Locking Nut—¼—28	.15
23612	Swivel Extension Clamp Bolt	.20	*X-539	Machine Screw No. 10—24 x ¼ Round Head	.10
23613	Lower Pull Rod	.65	X-546	Machine Screw ¼—20 x ¾ Fillister Head	.10
23615	Chuck Body	.60	X-602	Plain Washer ¼ I.D. x ¾ O.D.	.10
23622	Sleeve	.20	*X-605	Lock Washer ¼ I.D. x ½ O.D.	.10
23624	Spindle Snap Ring	.15	X-607	Plain Washer ¼ I.D. x 19/32 O.D.	.10
23626	Ferrule Nut	.15	*X-611	Lock Washer 5/16 I.D. x 19/32 O.D.	.10
23627	Spacer	.15	X-615	Plain Washer ¼ I.D. x 19/32 O.D.	.10
23629	Hold Down Foot Clamp Stud	.15	X-623	Plain Washer 5/16 I.D. x 7/8 O.D.—¼ Thick	.10
23638	Upper Pull Rod	.75	X-726	Screw No. 6—32 x ¼ Thread Forming	.10
23639	Snap Ring	.15	X-1127	Saw Blade 6 to 8½ inches long plain end. Purchase from your nearest Sears retail store or mail order house.	—
23641	Trunnion Nut	.50	X-1154	Light Bulb 7½ Watt	.40
23643	Snap Ring	.15	X-1326	Drive Screw No. 4 x 3/16	.10
23646	Wrench	.40			
23651	Connecting Rod (Short)	.40			

*Parts marked in this manner may be purchased locally.

This sheet is intended for instruction and repair parts only and is not a packing slip. The parts shown and listed may include accessories not necessarily part of this tool. All parts are shipped prepaid. All prices are subject to change without notice.

