

Copyright

Copyright

Fujitsu PC Corporation has made every effort to ensure the accuracy and completeness of this document; however, as ongoing development efforts are continually improving the capabilities of our products, we cannot guarantee the accuracy of the contents of this document. We disclaim liability for errors, omissions, or future changes.

Fujitsu, the Fujitsu logo, and LifeBook are registered trademarks of Fujitsu Limited.

The following are registered trademarks of IBM Corporation: IBM, IBM PC AT, IBM PS/2.

The following are registered trademarks of Microsoft Corporation: MS, MS-DOS, Windows.

PCMCIA is a trademark of the Personal Computer Memory Card International Association.

Earthlink is a registered trademark of EarthLink Network, Inc.

Intel and Pentium are registered trademarks of Intel Corporation or its subsidiaries in the United States and other countries.

Adobe Acrobat Reader is a registered trademark of Adobe Systems, Inc.

Netscape 7.0 is a registered trademark of Netscape Communications Corporation.

PowerQuest and Drive Image are registered trademarks of PowerQuest Corporation.

Norton AntiVirus is a registered trademark of Symantec Corporation.

BayManager is a registered trademark of Softex, Inc.

The DVD player found in some models of the LifeBook notebook incorporates copyright protection technology that is protected by method claims of certain U.S. patents and other intellectual property rights owned by Macrovision Corporation and other rights users. Use of this copyright protection technology must be authorized by Macrovision Corporation, and is intended for home and other limited viewing uses only unless authorized by Macrovision Corporation. Reverse engineering or disassembly is prohibited.

Dolby Headphone manufactured under license from Dolby Laboratories. "Dolby", "Pro Logic", and the double-D symbol are trademarks of Dolby Laboratories. Copyrights 1992-1999 Dolby Laboratories. All rights reserved.

All other trademarks mentioned herein are the property of their respective owners.

Warning



Handling the cord on this product will expose you to lead, a chemical known to the State of California to cause birth defects or other reproductive harm.

Wash hands after handling.

© Copyright 2003 Fujitsu PC Corporation. All rights reserved. No part of this publication may be copied, reproduced, or translated, without prior written consent of Fujitsu. No part of this publication may be stored or transmitted in any electronic form without the written consent of Fujitsu.

B5FH-9991-01EN-00



DECLARATION OF CONFORMITY

according to FCC Part 15

Responsible Party Name:	Fujitsu PC Corporation
Address:	5200 Patrick Henry Drive Santa Clara, CA 95054
Telephone:	(408) 982-9500
Declares that product:	Base Model Configurations: LifeBook S6120 notebook LifeBook S6120D notebook Complies with Part 15 of the FCC Rules.

This device complies with Part 15 of the FCC rules. Operations are subject to the following two conditions:

- (1) This device must not be allowed to cause harmful interference, (2) This device must accept any interference received, including interference that may cause undesired operation.

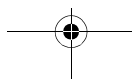



LifeBook S6000 Notebook

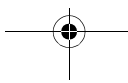
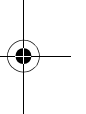
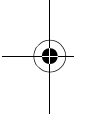

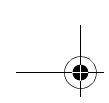

Fujitsu LifeBook® S6000 Notebook Table of Contents

1

PREFACE

Preface

About This Guide	1
Fujitsu Contact Information	1
Limited Warranty	1

2

GETTING TO KNOW YOUR LIFEBOOK NOTEBOOK

Overview

Unpacking	5
---------------------	---

Locating the Controls and Connectors

Top and Front Components	6
Left-Side Panel Components	7
Right-Side Panel Components	8
Back Panel Components	9
Bottom Components	10

Status Indicator Panel

Power Indicator	11
AC Adapter Indicator	11
Battery Level Indicators	11
Battery Charging Indicators	12
DVD/CD-RW/CD-ROM	
Drive Access Indicator	12
Hard Drive or Removable	
Media Drive Access Indicator	12
PC Card Access Indicator	12
NumLk Indicator	12
CapsLock Indicator	12
ScrLk Indicator	12
Security Indicator	12

Keyboard

Using the Keyboard	13
Numeric Keypad	13
Windows Keys	13
Cursor Keys	14
Function Keys	14

Touchpad Pointing Device

Clicking	15
Double-Clicking	15
Dragging	16
Touchpad Control Adjustment	16
Scrolling	16

Volume Control

Controlling the Volume	17
----------------------------------	----

Flexible Bay Devices

Removing and Installing	
Modular Devices	18

LifeBook Security/Application Panel

Setting up Your LifeBook Security Panel	20
Passwords	20
Operating Your LifeBook Security/	
Application Panel	21
Precautions	21
Uninstalling the Security Panel Application	21
Launching Applications with	
the Security/Application Panel	22

3

GETTING STARTED WITH YOUR LIFEBOOK NOTEBOOK

Power Sources

Connecting the Power Adapters	27
---	----

Display Panel

Opening the Display Panel	28
Adjusting Display Panel Brightness	28
Closing the Display Panel	28

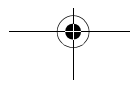

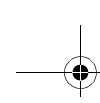

Starting Your LifeBook Notebook

Power On	29
Boot Sequence	29
BIOS Setup Utility	29
Booting the System	30
Windows Product Activation	30
Registering Your LifeBook Notebook	31
Installing Click Me!	31

Power Management

Power/Suspend/Resume Button	32
Suspend Mode	32
Hibernation (Save-to-Disk) Feature	32
Display Timeout	33
Hard Disk Timeout	33
Windows Power Management	33
Restarting the System	33
Power Off	33

4

USER-INSTALLABLE FEATURES

Lithium ion Battery

Recharging the Batteries	37
Replacing the Battery	38

Media Player Drive

Media Player Software	39
Loading Media on Your Drive	39
Removing Media	40
Using the Media Player Software	40
Using Dolby™ Headphone	41
Using Media Player on Battery Power	41

External USB Floppy Disk Drive

Loading a Disk	42
Ejecting a Disk	42
Preparing a Disk for Use	42

PC Cards

Installing PC Cards	43
Removing PC Cards	43
Smart Card Reader	44

Memory Upgrade Module

Installing Memory Upgrade Modules	45
To Remove a Memory Upgrade Module	45
Checking the Memory Capacity	46

Port Replicator

Back Panel Components	47
Front Panel Components	48
Attaching the Port Replicator	48
Detaching the Port Replicator	48

Device Ports

Modem (RJ-11) Telephone Jack	49
Internal LAN (RJ-45) Jack	49
Parallel Port	49
Serial Port	50
PS/2 Port	50
Docking Port	50
Universal Serial Bus Ports	50
Infrared Port	50
Stereo Line-In Jack	51
IEEE 1394 Port	51
Headphone Jack	51
Microphone Jack	51
External Monitor Port	51

5

TROUBLESHOOTING YOUR LIFEBOOK NOTEBOOK

Troubleshooting

Identifying the Problem	55
Specific Problems	55
Troubleshooting Table	56
Power On Self Test Messages	64
Emergency media Player Drive Tray Release	65
Modem Result Codes	65
Restoring Your Pre-installed Software	66
Drive Image Special Edition (DISE)	66

6

CARING FOR YOUR LIFEBOOK NOTEBOOK

Care and Maintenance

Batteries	72
Floppy Disks and Drives	72
Media Care	72
PC Cards	73

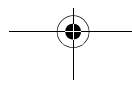

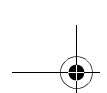

Table of Contents

7

SYSTEM SPECIFICATIONS

Specifications

Configuration Label	77
Microprocessor	77
Chipset	77
Memory	77
Video	77
Audio	77
Mass Storage Device Options	77
Features	78
Device Ports	78
Keyboard	78
Power	78
Wireless LAN	78
Dimensions and Weight	79
Environmental Requirements	79
Popular Accessories	79
Pre-Installed Software	79
Learning About Your Software	79

8

GLOSSARY

Glossary	83
Regulatory Information	89

APPENDIX:

WIRELESS LAN USER'S GUIDE

FCC Regulatory Information	95
--------------------------------------	----

Before Using the Wireless LAN

For better communications	97
Stopping transmission	98
Starting Transmission	98

Connection using Windows XP

Flow of operations	99
Preparation for wireless LAN connection	99
Connection to the network	101

Connection using Windows 2000

Flow of operations	105
Preparation for wireless LAN connection	105
Connection to the network	107

Other settings

Setting of power-saving function	111
--	-----

Troubleshooting the WLAN

Troubleshooting	112
---------------------------	-----

Wireless LAN Glossary

Glossary	115
--------------------	-----

IP address information

Additional Information	117
----------------------------------	-----

WLAN Specifications

Specification	118
-------------------------	-----

Index	119
------------------------	------------

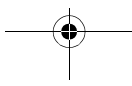

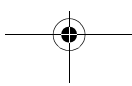
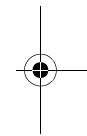
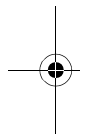
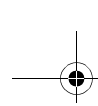

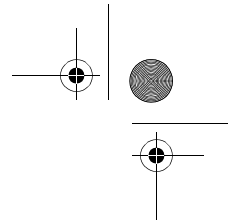
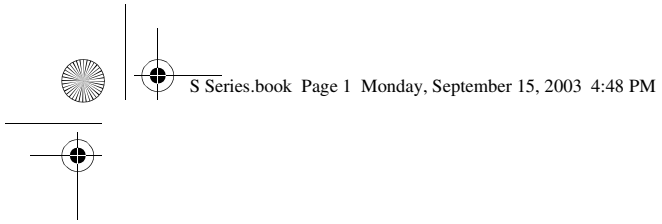

1 Preface

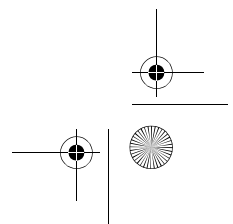
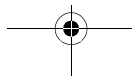
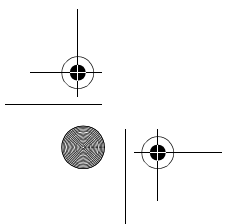
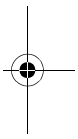
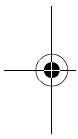

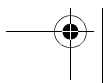
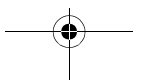
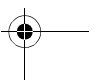
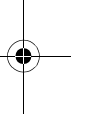
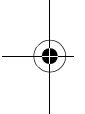



Preface

ABOUT THIS GUIDE

The LifeBook S6000 notebook from Fujitsu is a powerful computer. It is powered by an Intel Pentium M micro-processor, has a built-in color display, a number of possible configurations, and brings the computing power of desktop personal computers (PCs) to a portable environment.

This manual explains how to operate your LifeBook notebook's hardware and built-in system software. Your notebook is compatible with the IBM® PC AT.

It comes with Microsoft Windows® XP Home, Windows XP Professional, or Windows 2000 Professional pre-installed.

The LifeBook S6000 notebook is a completely self-contained unit with an active-matrix (TFT) color LCD display. It has a powerful interface that enables it to support a variety of optional features.

Conventions Used in the Guide

Keyboard keys appear in brackets.

Example: [Fn], [F1], [ESC], [ENTER] and [CTRL].

Pages with additional information about a specific topic are cross-referenced within the text.

Example: (See page xx.)

On screen buttons or menu items appear in bold

Example: Click **OK** to restart your LifeBook notebook.

DOS commands you enter appear in Courier type.

Example: Shutdown the computer?



POINT

The point icon highlights information that will enhance your understanding of the subject material.



CAUTION

The caution icon highlights information that is important to the safe operation of your computer, or to the integrity of your files. Please read all caution information carefully.



WARNING

The warning icon highlights information that can be hazardous to you, your LifeBook notebook, or your files. Please read all warning information carefully.

FUJITSU CONTACT INFORMATION

Service and Support

You can contact Fujitsu Service and Support in the following ways:

- Toll free: 1-800-8Fujitsu (1-800-838-5487)
- Fax: 1-901-259-5700
- E-mail: 8fujitsu@fujitsupc.com
- Web site: <http://www.fujitsupc.com>

Before you place the call, you should have the following information ready so that the customer support representative can provide you with the fastest possible solution:

- Product name
- Product configuration number
- Product serial number
- Purchase date
- Conditions under which the problem occurred
- Any error messages that have occurred
- Hardware configuration
- Type of device connected, if any

FPC Online

You can go directly to the online FPC Product catalog for your LifeBook notebook by clicking on the LifeBook Accessories Web site URL link located in the Service and Support Software folder of the Windows Start menu.

You can also reach FPC Service and Support online by clicking on the FPC Service and Support Web site URL link, located in the Service and Support Software folder of the Windows Start menu.



POINT

You must have an active internet connection to use the online URL links.

LIMITED WARRANTY

Your LifeBook notebook is backed by a Fujitsu International Limited Warranty. Check the service kit that came with your notebook for the Limited Warranty period and terms and conditions.

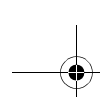

LifeBook S6000 Notebook

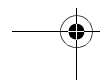
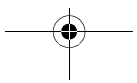
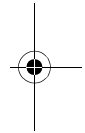
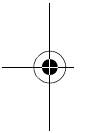

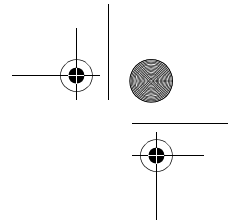
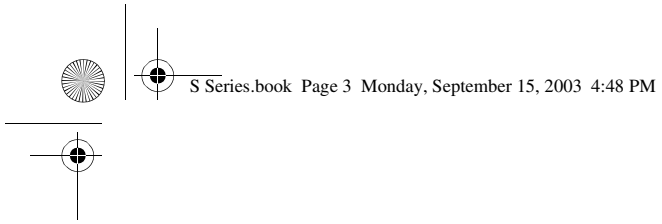

2

Getting to Know Your LifeBook Notebook

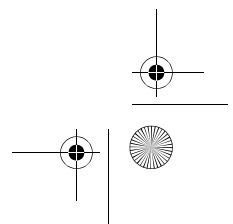
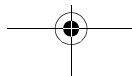
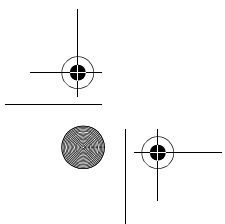
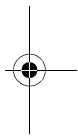
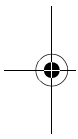

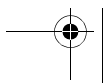
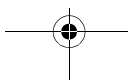
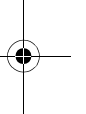
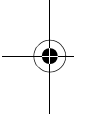
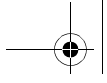

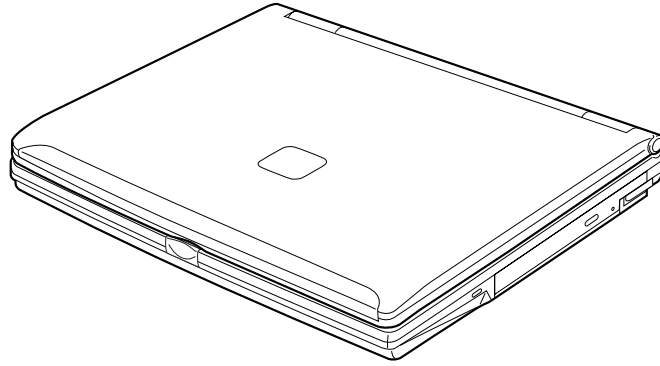

Figure 2-1. Fujitsu LifeBook S6000 notebook

Overview

This section describes the components of your Fujitsu LifeBook S6000 notebook. We strongly recommend that you read it before using your notebook – even if you are already familiar with notebook computers.

UNPACKING

When you receive your LifeBook notebook, unpack it carefully, and compare the parts you have received with the items listed below.

For a pre-configured model you should have:

- LifeBook S6000 notebook (Figure 2-1)
- AC adapter with AC power cord (Figure 2-2)
- Lithium ion Battery, pre-installed
- Weight Saver
- Phone/Modem (RJ-11) telephone cable
- Driver and Application Restore (DAR) CD
- Getting Started Guide
- User's Guide (this document)
- International Limited Warranty Brochure
- Microsoft®-associated product materials
- Premium Care Registration card and envelope

Depending on your system configuration, you will receive one of the following devices, pre-installed in the Flexible Bay:

- Weight Saver
- Modular CD-ROM drive
- Modular DVD drive
- Modular DVD/CD-RW combo drive

Depending on your system configuration, the following optional items may be included with your system:

- Port Replicator (Figure 2-3)
- Modular 2nd bay battery
- External USB floppy disk drive

Depending on your configuration, you may receive the following application CDs:

- DVD Application CD
- CD-RW Application CD

Once you have checked and confirmed that your LifeBook system is complete, read through the following pages to learn about all of your notebook's components.

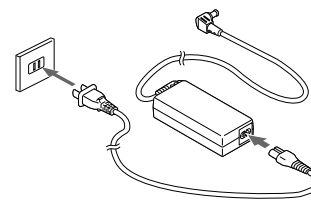

Figure 2-2 AC Adapter

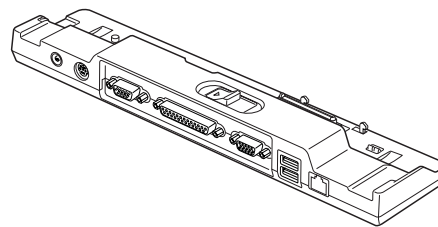

Figure 2-3 Port Replicator (optional)

LifeBook S6000 Notebook

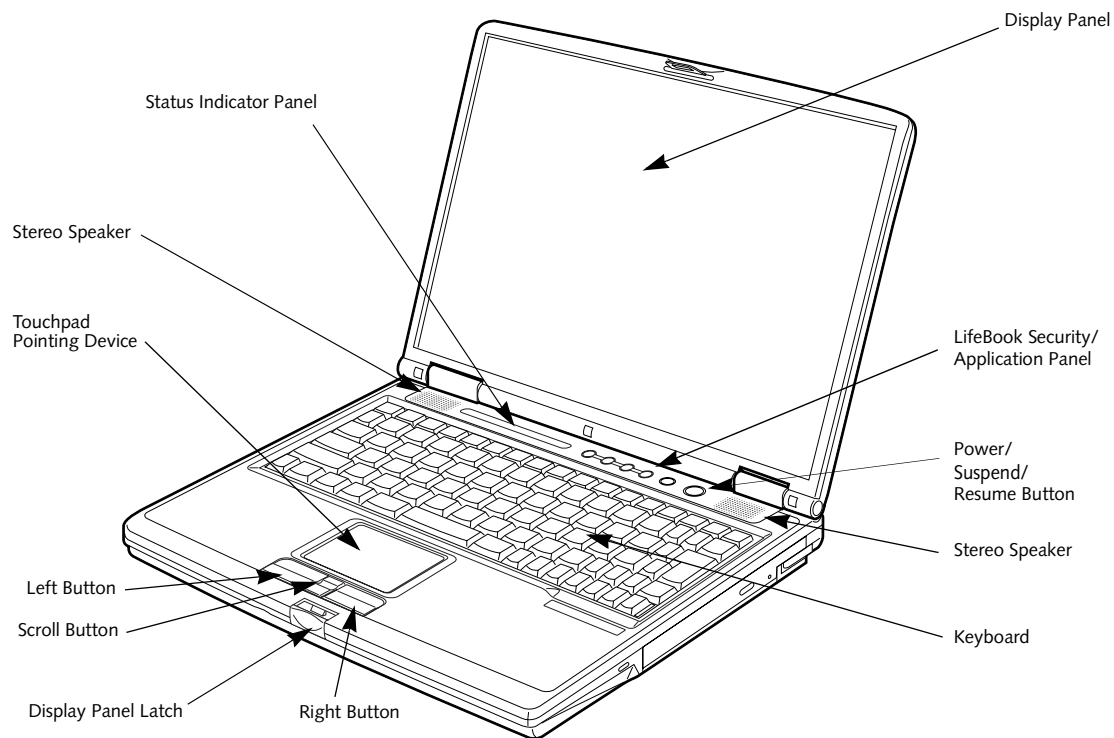

Figure 2-4. LifeBook notebook with display open

Locating the Controls and Connectors

TOP AND FRONT COMPONENTS

The following is a brief description of your LifeBook notebook's top and front components.

Display Panel Latch

The display panel latch locks and releases the display panel.

Display Panel

The display panel is a color LCD panel with back lighting for the display of text and graphics.

Keyboard

A full-size keyboard with dedicated Windows keys. (See *Keyboard* on page 13 for more information)

Status Indicator Panel

The Status Indicator Panel displays symbols that correspond with a specific component of your LifeBook notebook. (See *Status Indicator Panel* on page 11 for more information)

Power/Suspend/Resume Button

The Power/Suspend/Resume button allows you to suspend notebook activity without powering off, resume your LifeBook notebook from suspend mode, and power on your notebook when it has been shut down from Windows. (See *Power/Suspend/Resume Button* on page 32 for more information)

Stereo Speakers

The built-in dual speakers allow for stereo sound.

Touchpad Pointing Device

The Touchpad pointing device is a mouse-like cursor control with three buttons: two mouse-like buttons, and a scroll button. (See *Touchpad Pointing Device* on page 15 for more information)

LifeBook Security/Application Panel

The LifeBook Security/Application Panel provides hardware security and one-touch application launch capability. (See *LifeBook Security/Application Panel* on page 20 for more information)

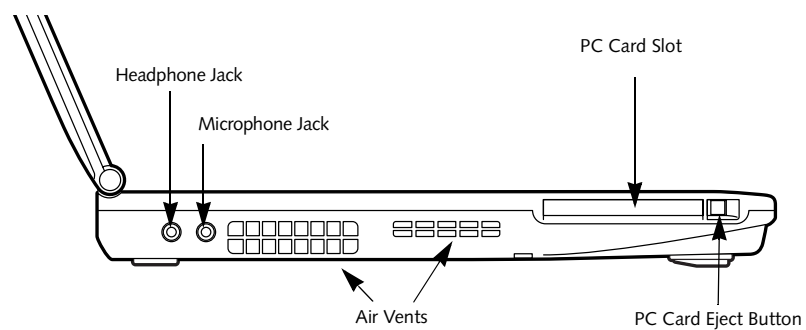
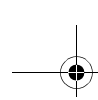

Figure 2-5. LifeBook notebook left-side panel

LEFT-SIDE PANEL COMPONENTS

The following is a brief description of your LifeBook notebook's left-side components.

Headphone Jack

The headphone jack allows you to connect headphones or powered external speakers. (See *Headphone Jack on page 51 for more information*)

Microphone Jack

The microphone jack allows you to connect an external mono microphone. (See *Microphone Jack on page 51 for more information*)

PC Card Slot

The PC Card Slot allows you to install one Type II PC Card. (See *PC Cards on page 43 for more information*)

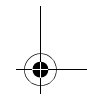
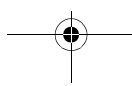
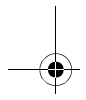
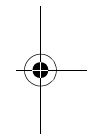
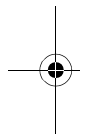

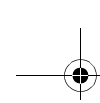

LifeBook S6000 Notebook

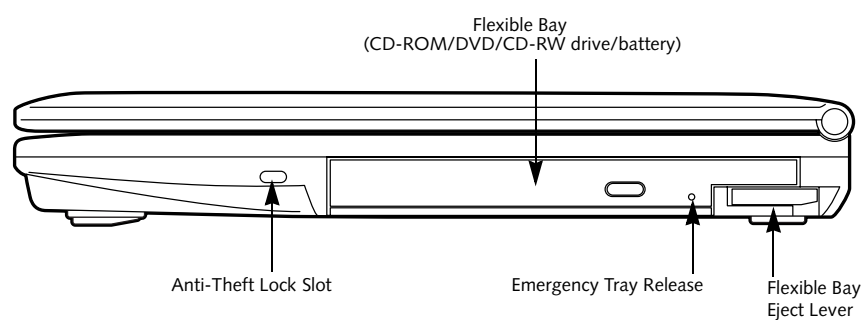

Figure 2-6. LifeBook notebook right-side panel

RIGHT-SIDE PANEL COMPONENTS

The following is a brief description of your LifeBook notebook's right-side components.

Flexible Bay

The Flexible Bay can accommodate one of the following devices. (See *Flexible Bay Devices on page 18 for more information*)

- Modular DVD drive
- Modular CD-ROM drive
- Modular DVD/CD-RW combo drive
- Modular Lithium ion battery
- Weight Saver

Flexible Bay Eject Lever

The Flexible Bay eject lever releases the Flexible Bay device.

Emergency Tray Release

The Emergency Tray Release allows you to open the CD tray without powering on your LifeBook notebook.

Anti-theft Lock Slot

The anti-theft lock slot allows you to attach an optional physical lock down device.

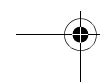
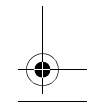
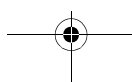
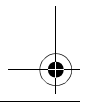
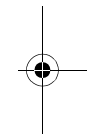
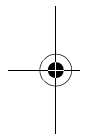

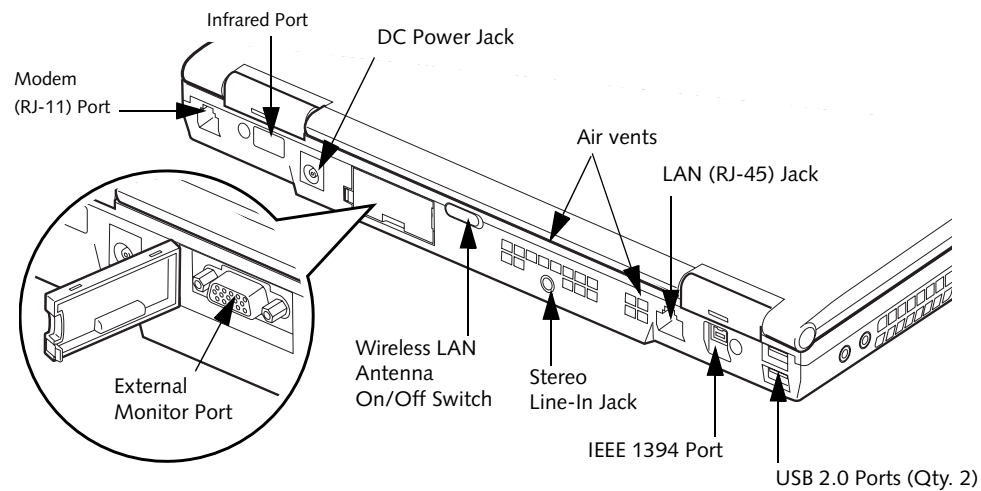

Figure 2-7. LifeBook notebook back panel

BACK PANEL COMPONENTS

Following is a brief description of your LifeBook notebook's back panel components.

Infrared Port

The fast IrDA compatible port allows you to communicate with another IrDA compatible infrared device without a cable. (See *Infrared Port* on page 50 for more information)

DC Power Jack

The DC power jack allows you to plug in the AC adapter or the optional Auto/Airline adapter to power your notebook and charge the internal Lithium ion battery.

USB 2.0 Ports

The USB 2.0 ports allow you to connect Universal Serial Bus devices. USB 2.0 transfers data at up to 480Mbps and is backward-compatible with USB 1.1 devices, which transfer data at up to 12Mbps. (See *Universal Serial Bus Ports* on page 50 for more information)

LAN (RJ-45) Jack

The internal LAN (RJ-45) jack is used for an internal Fast Ethernet (10/100 Base-TX) connection. (See *Internal LAN (RJ-45) Jack* on page 49 for more information)

Wireless LAN Antenna On/Off Switch

The Wireless LAN Antenna On/Off Switch turns the optional wireless LAN on and off.

Stereo Line-in Jack

The stereo line-in jack allows you to connect an external audio source. (See *Stereo Line-In Jack* on page 51 for more information)

IEEE 1394 (4-pin) Jack

The 4-pin 1394 jack is used to connect between your LifeBook and an IEEE 1394 peripheral such as a digital video camera. (See *IEEE 1394 Port* on page 51 for more information)

External Monitor Port

The external monitor port allows you to connect an external monitor. (See *External Monitor Port* on page 51 for more information)

Modem (RJ-11) Telephone Port

The Modem (RJ-11) telephone jack is for attaching a telephone line to the internal multinational 56K modem. (See *Modem (RJ-11) Telephone Jack* on page 49 for more information)

WARNING

The internal modem is not intended for use with Digital PBX systems. Do not connect the internal modem to a Digital PBX as it may cause serious damage to the internal modem or your entire notebook. Consult your PBX manufacturer's documentation for details. Some hotels have Digital PBX systems. Be sure to find out BEFORE you connect your modem.

POINT

The internal multinational modem is designed to the ITU-T V.90 standard. Its maximum speed of 53000bps is the highest allowed by FCC, and its actual connection rate depends on the line conditions. The maximum speed is 33600bps at upload.

For additional information about the multinational modem, refer to the Fujitsu web site at: www.fujitsupc.com/modems

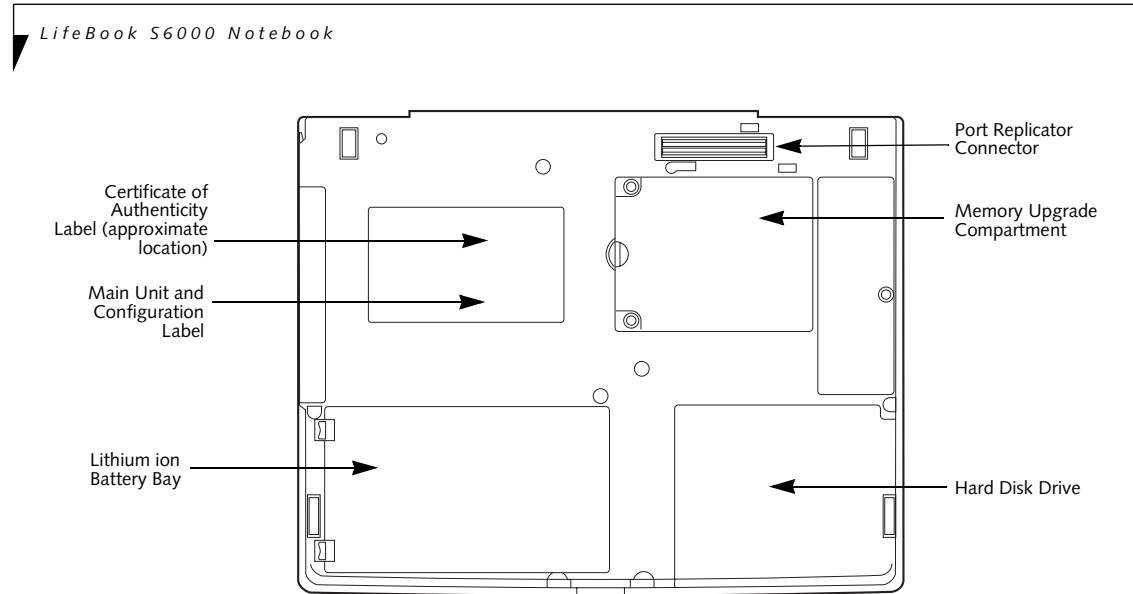

Figure 2-8. LifeBook notebook bottom panel

BOTTOM COMPONENTS

The following is a brief description of your LifeBook notebook's bottom panel components.

Port Replicator Connector

This connector allows you to connect the optional Port Replicator to your notebook.

Memory Upgrade Compartment

Your LifeBook notebook comes with high speed Double Data Rate Synchronous Dynamic RAM (DDR SDRAM). The memory upgrade compartment allows you to expand the system memory capacity of your LifeBook notebook, hence improving overall performance. (See *Memory Upgrade Module on page 45 for more information*)

Lithium ion Battery Bay

The battery bay contains the internal Lithium ion battery. It can be opened for the removal of the battery when stored over a long period of time or for swapping a discharged battery with a charged Lithium ion battery. (See *Lithium ion Battery on page 37 for more information*)

Main Unit and Configuration Label

The configuration label shows the model number and other information about your LifeBook notebook. In addition, the configuration portion of the label has the serial number and manufacturer information that you will need to give your support representative. It identifies the exact version of various components of your notebook.

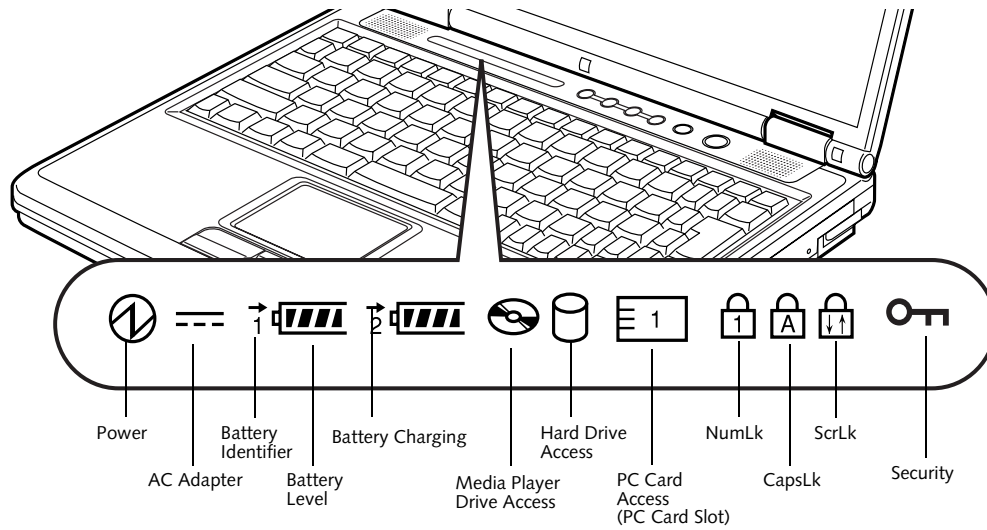

Figure 2-9. Status Indicator Panel

Status Indicator Panel

The Status Indicator displays symbols that correspond with a specific component of your Fujitsu LifeBook notebook. These symbols tell you how each of those components are operating. (Figure 2-9)

POWER INDICATOR

The Power indicator symbol states whether your system is operational. It has several different states, each of which tells you the mode your notebook is in.

- **Steady On:** This means that there is power to your LifeBook notebook and that it is ready for use.
- **Flashing:** This means that your LifeBook notebook is in Suspend mode.
- **Steady Off:** This means that your system is either in Save-to-Disk mode, or that your LifeBook notebook has been turned off.

If you are charging your battery, the Power indicator will remain on even if your notebook is shut off. The Power indicator will also remain on if you have either adapter connected and are shut down from Windows.

AC ADAPTER INDICATOR

The AC Adapter indicator states whether your notebook is operating from the AC adapter, the Auto/Airline adapter or the batteries. This icon has two different states that can tell you what power source your LifeBook notebook is using.

- **On:** This means that either of the adapters are currently in use.
- **Off:** Power is only coming from the batteries, and you do not have an adapter connected.

BATTERY LEVEL INDICATORS

The two Battery Level indicators state whether or not the primary Lithium ion battery and/or the optional second Lithium ion battery are installed (Battery 1 refers to the primary Lithium ion battery, while Battery 2 refers to the Flexible Bay optional second battery). In addition, this symbol states how much charge is available within each installed battery. The symbol will only be displayed for a battery that is currently installed in your LifeBook notebook. (Figure 2-10)

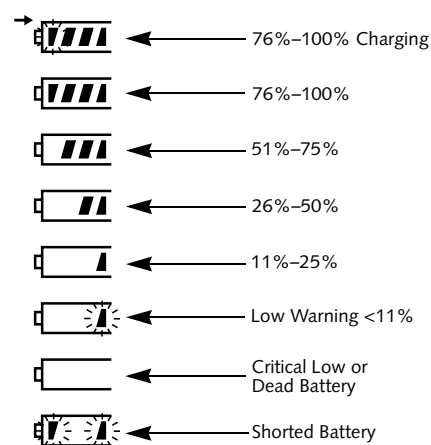

Figure 2-10 Battery Level Indicator

CAUTION

A shorted battery is damaged and must be replaced. (Figure 2-10)

LifeBook S6000 Notebook

→ BATTERY CHARGING INDICATORS

Located to the left of each of the Battery Level indicators is a small arrow symbol. This symbol states whether that specific battery is charging. This indicator will flash if the battery is too hot or cold to charge.

CAUTION

Batteries subjected to shocks, vibration or extreme temperatures can be permanently damaged.

DVD/CD-RW/CD-ROM DRIVE ACCESS INDICATOR

The DVD/CD-RW/CD-ROM Access indicator tells you that the DVD/CD-RW/CD-ROM drive is being accessed. If the Auto Insert Notification function is active, the indicator will flash periodically when your system is checking the DVD/CD-RW/CD-ROM drive. If the Auto Insert Notification function is not active, the indicator will only flash when you access the DVD/CD-RW/CD-ROM drive. The default setting is the Auto Insert Notification function active.

POINT

The DVD/CD-RW/CD-ROM Auto Insert Notification function will periodically check for a DVD/CD-RW/CD-ROM installed in the drive, causing the DVD/CD-RW/CD-ROM Access indicator to flash. The DVD/CD-RW/CD-ROM Auto Insert Notification function allows your system to automatically start a DVD/CD-RW/CD-ROM as soon as it is inserted in the drive and the tray is closed. It will begin playing an audio DVD/CD or will start an application if the DVD/CD has an auto-run file

HARD DRIVE OR REMOVABLE MEDIA DRIVE ACCESS INDICATOR

The Hard Drive Access indicator states whether your internal hard drive is being accessed.

POINT

The Hard Drive Access indicator does not show which hard drive is being accessed.

PC CARD ACCESS INDICATOR

The PC Card Access indicator states whether or not your notebook is accessing a PC Card. The indicator will flash

if your software tries to access a PC Card even if there is no card installed. (See *PC Cards on page 43 for more information*)

NUMLK INDICATOR

The NumLk indicator states that the integral keyboard is set in ten-key numeric keypad mode.

POINT

If you are using the optional external numerical keypad, pressing the [NumLk] key will activate the external keypad. The indicator will come on, however it will not change any of the functionality of your keyboard keys.

CAPSLOCK INDICATOR

The CapsLock indicator states that your keyboard is set to type in all capital letters.

SCRCLK INDICATOR

The ScrLk indicator states that your scroll lock is active.

SECURITY INDICATOR

The Security Indicator flashes (if a password was set) when the system resumes from Off or Standby modes. You must enter the password that was set in the Security Panel before your system will resume operation.

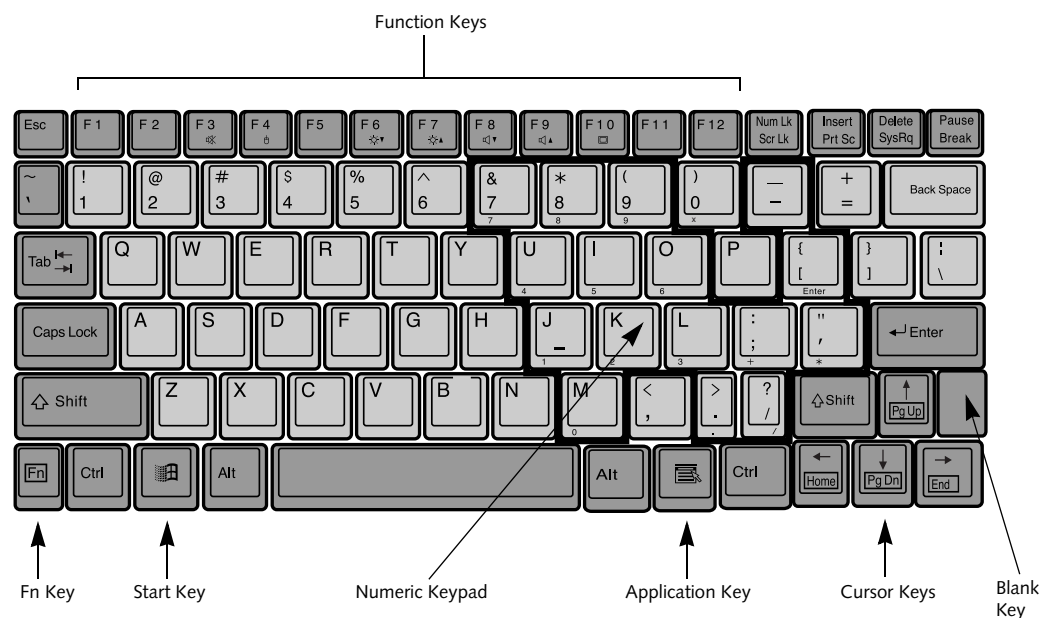

Figure 2-11 Keyboard

Keyboard

USING THE KEYBOARD

Your Fujitsu LifeBook notebook has an integral 82-key keyboard. The keys perform all the standard functions of a 101-key keyboard, including the Windows keys and other special function keys. This section describes the following keys. (Figure 2-11)

- **Numeric keypad:** Your notebook allows certain keys to serve dual purposes, both as standard characters and as numeric and mathematical keys. The ability to toggle between the standard character and numerical keys is controlled through the [NumLk] key.
- **Cursor keys:** Your keyboard contains four arrow keys for moving the cursor or insertion point to the right, left, up, or down within windows, applications and documents.
- **Function keys:** The keys labeled [F1] through [F12], are used in conjunction with the [Fn] key to produce special actions that vary depending on what program is running.
- **Windows keys:** These keys work with your Windows operating system and function the same as the onscreen Start menu button, or the right button on your pointing device.

NUMERIC KEYPAD

Certain keys on the keyboard perform dual functions as both standard character keys and numeric keypad keys. NumLk can be activated by pressing the [NumLk] keys. Turning off the NumLk feature is done the same way. Once this feature is activated you can enter numerals 0 through 9, perform addition (+), subtraction (-), multiplication (*), or division (/), and enter decimal points (.) using the keys designated as ten-key function keys. The keys in the numeric keypad are marked on the front edge of the key to indicate their secondary functions. (Figure 2-11)

POINT

If you are using the optional external numerical keypad, pressing the [NumLk] key will activate the external keypad. The indicator will come on, however it will not change any of the functionality of your keyboard keys.

WINDOWS KEYS

Your LifeBook notebook has two Windows keys, consisting of a Start key and an Application key. The Start key displays the Start menu. This button functions the same as your onscreen Start menu button. The Application key functions the same as your right mouse button and displays shortcut menus for the selected item. (Please refer to your Windows documentation for additional information regarding the Windows keys.) (Figure 2-11)

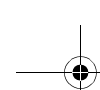

CURSOR KEYS

The cursor keys are the four arrow keys on the keyboard which allow you to move the cursor up, down, left and right in applications. In programs such as Windows Explorer, it moves the “focus” (selects the next item up, down, left, or right). (Figure 2-11)

FUNCTION KEYS

Your LifeBook notebook has 12 function keys, F1 through F12. The functions assigned to these keys differ for each application. You should refer to your software documentation to find out how these keys are used. (Figure 2-11)

The [Fn] key provides extended functions for the notebook and is always used in conjunction with another key.

- [Fn+F3]: Pressing [F3] while holding [Fn] will toggle the Audio Mute on and off.
- [Fn+F4]: Pressing [F4] while holding [Fn] will toggle the Quick Point feature on and off. Note that the [Fn+F4] combination only works if Manual Setting is selected in the BIOS. (See “BIOS Setup Utility” on page 29)
- [Fn+F6]: Pressing [F6] repeatedly while holding [Fn] will lower the brightness of your display.*
- [Fn+F7]: Pressing [F7] repeatedly while holding [Fn] will increase the brightness of the display.*
- [Fn+F8]: Pressing [F8] repeatedly while holding [Fn] will decrease the volume of your LifeBook notebook.**
- [Fn+F9]: Pressing [F9] repeatedly while holding [Fn] will increase the volume of your LifeBook notebook.**
- [Fn+F10]: Pressing [F10] while holding [Fn] allows you to change your selection of where to send your display video. Each time you press the combination of keys you will step to the next choice. The choices, in order, are: built-in display panel only, external monitor only, or both built-in display panel and external monitor.

* There are eight brightness levels.

** There are 26 audio levels.

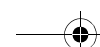

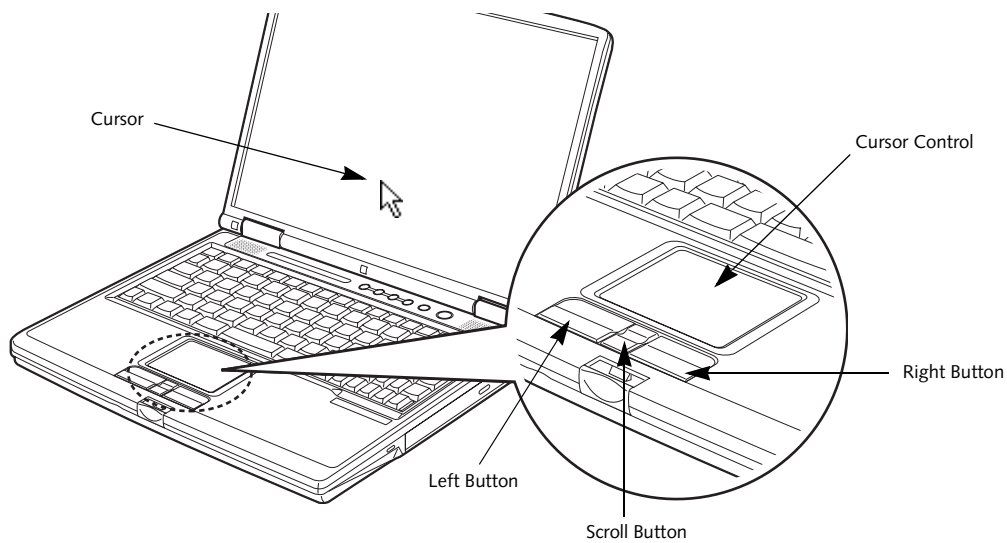
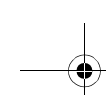

Figure 2-12. Touchpad pointing device

Touchpad Pointing Device

The Touchpad pointing device comes built into your Fujitsu LifeBook notebook. It is used to control the movement of the pointer to select items on your display panel. The Touchpad is composed of a cursor control, a left and right button, and a scrolling button. The cursor control works the same way a mouse does, and moves the cursor around the display. It only requires light pressure with the tip of your finger. The left and right buttons function the same as mouse buttons. The actual functionality of the buttons may vary depending on the application that is being used. The scrolling button allows you to navigate quickly through pages, without having to use the scroll bars. (Figure 2-12)



POINT

An external mouse can be connected to either the USB or PS/2 port on your LifeBook notebook or the optional port replicator, and used simultaneously with the Touchpad. However, if you boot the system with an external mouse connected the Touchpad will be disabled or enabled depending on the specifications in your BIOS settings. (See *BIOS Setup Utility on page 29 for more information*)

CLICKING

Clicking means pushing and releasing a button. To left-click, move the cursor to the item you wish to select, press the left button once, and then immediately release it. To right-click, move the mouse cursor to the item you wish to select, press the right button once, and then immediately release it. You also have the option to perform the clicking operation by tapping lightly on the Touchpad once. (Figure 2-13)

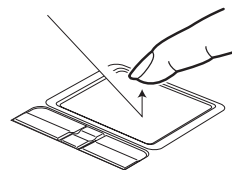

Figure 2-13 Clicking

DOUBLE-CLICKING

Double-clicking means pushing and releasing the left button twice in rapid succession. This procedure does not function with the right button. To double-click, move the cursor to the item you wish to select, press the left button twice, and then immediately release it. You also have the option to perform the double-click operation by tapping lightly on the Touchpad twice. (Figure 2-14)

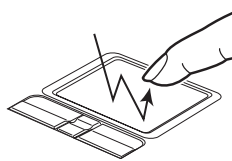
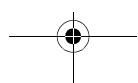

Figure 2-14 Double-clicking



POINT

If the interval between clicks is too long, the double-click will not be executed.



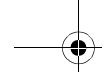

 **POINT**

Parameters for the Touchpad can be adjusted from the Mouse Properties dialog box located in the Windows Control Panel.

DRAGGING

Dragging means pressing and holding the left button, while moving the cursor. To drag, move the cursor to the item you wish to move. Press and hold the left button while moving the item to its new location and then release it. Dragging can also be done using the Touchpad. First, tap the Touchpad twice over the item you wish to move making sure to leave your finger on the pad after the final tap. Next, move the object to its new location by moving your finger across the Touchpad, and then release your finger. (Figure 2-15)

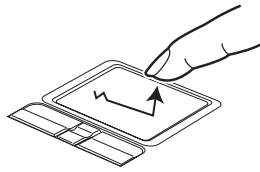

Figure 2-15 Dragging

TOUCHPAD CONTROL ADJUSTMENT

The Windows Control Panel allows you to customize your Touchpad with selections made from within the Mouse Properties dialog box.

SCROLLING

Using the Scrolling button allows you to navigate through a document quickly without using the window's scroll bars. This is particularly useful when you are navigating through on-line pages. To use the Scrolling button, press the crescent shape at the top or bottom of the button to scroll up or down a page. When you have reached the desired section of the page, release the button. (Figure 2-16)

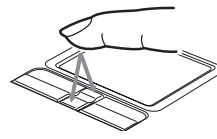
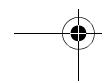
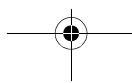
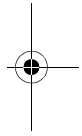
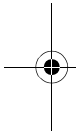

Figure 2-16 Scrolling





Volume Control

Your Fujitsu LifeBook notebook has multiple volume controls which interact with each other.

POINT

Any software that contains audio files will also contain a volume control of its own. If you install an external audio device that has an independent volume control, the hardware volume control and the software volume control will interact with each other. It should be noted that if you set your software volume to Off, you will override the external volume control setting.

CONTROLLING THE VOLUME

The volume can be controlled in several different ways:

- Volume can be set from within the Volume Control on the Taskbar.
- Volume can be controlled with the F8 and F9 functions keys. Pressing [F8] repeatedly while holding [Fn]

will decrease the volume of your notebook. Pressing [F9] repeatedly while holding [Fn] will increase the volume of your notebook.

POINT

There are 26 levels through which the function keys cycle.

- Volume can be controlled by many volume controls that are set within individual applications.
- Certain external audio devices you might connect to your system may have hardware volume controls.

Each source discussed above puts an upper limit on the volume level that must then be followed by the other sources.

We recommend that you experiment with the various volume controls to discover the optimal sound level.

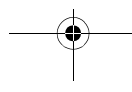
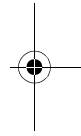
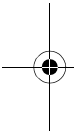

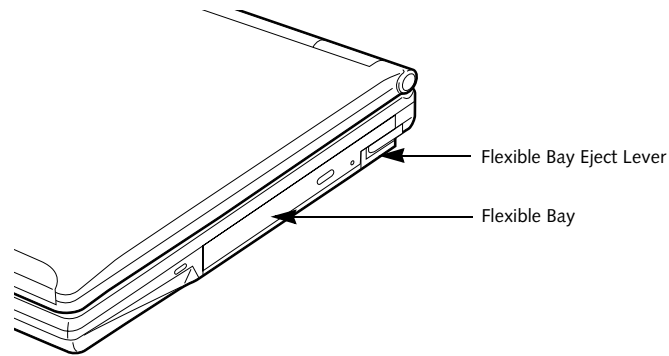

Figure 2-17 Flexible Bay

Flexible Bay Devices

Your Fujitsu LifeBook notebook contains a Flexible Bay. The Flexible Bay can accommodate a modular DVD drive, CD-ROM drive, DVD/CD-RW combo drive, Lithium ion battery, and weight saver. (Figure 2-17)

Your Flexible Bay will have one of the following devices installed. (Figure 2-18)

- **Modular DVD drive:** This allows you to access movies, software, and audio DVD/CDs.
- **Modular DVD/CD-RW combo drive:** This allows you to access movies, software, and audio DVD/CDs as well as to write to CDs.
- **Modular CD-ROM drive:** This allows you to access software, data, or audio CDs.
- **Modular Lithium ion battery:** This is a rechargeable battery that can be used to power your LifeBook notebook when an adapter is not connected.
- **Weight Saver:** This is used to fill the bay when no device is needed.

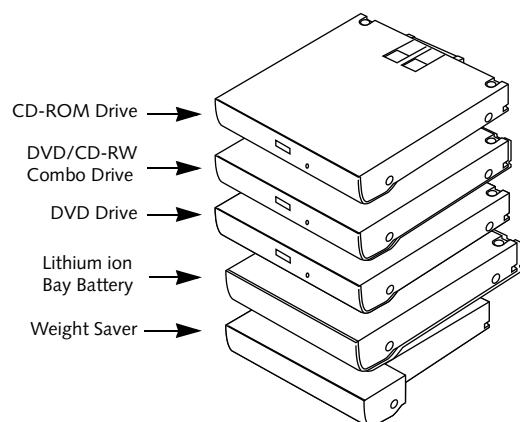

Figure 2-18 Flexible Bay Devices

REMOVING AND INSTALLING MODULAR DEVICES

There are two ways to remove and install modular devices in the Flexible Bay:

- **Cold-swapping:** swapping devices while your LifeBook notebook is powered off.
- **Hot-swapping:** swapping devices while your system is active using the Unplug/Eject icon from your taskbar. Note that if the weight saver is installed rather than a modular device, it is not necessary to use BayManager when removing it.

CAUTION

You should never leave your Flexible Bay empty when the notebook is in operation. If left empty, dust or foreign matter may accumulate inside the notebook.

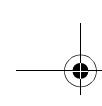

Cold-swapping

To cold-swap modular devices in your Flexible Bay follow these easy steps: (Figure 2-19)

1. Close any open files.
2. Shut down your LifeBook notebook.
3. Pull out the Flexible Bay eject lever. This will push your device out slightly, allowing you to remove the device.
4. Slide your device out until it is clear of the bay. This will require light force.

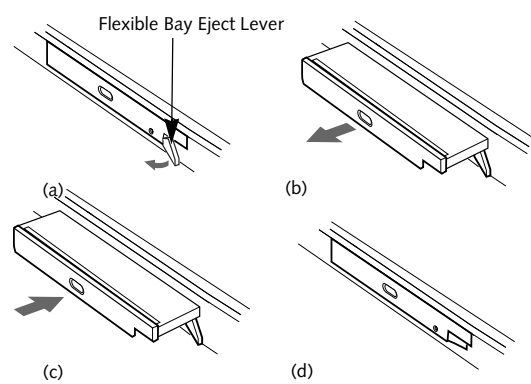

Figure 2-19 Removing/Installing a device in the Flexible Bay

CAUTION

Be careful when aligning and seating devices in the bay. If the fit is incorrect, you may damage the bay or the device. If the device does not move easily in the bay, remove it, and check for dirt or foreign objects. It will require a firm push to latch the device in place.

5. Slide the device you are installing into your notebook until it clicks into place.
6. It is now safe to turn your notebook back on.
7. You can now access and use the device.

Your LifeBook notebook will automatically detect the new device and activate it within your system. The drive letters associated with the device will be created and listed under My Computer and Windows Explorer.

Hot-swapping

Under Windows 2000 Professional, Windows XP Home, and Windows XP Professional, hot-swapping is provided through the Unplug or Eject Hardware utility.

The icon for the utility appears on the taskbar. Click on the icon and follow the on-screen instructions.

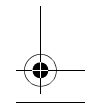
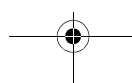
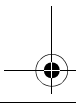
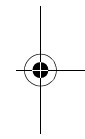
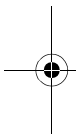

LifeBook S6000 Notebook

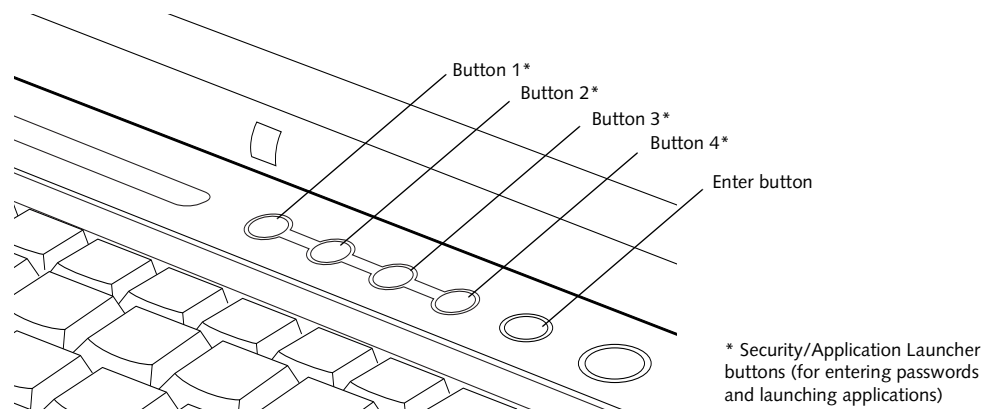

Figure 2-20 LifeBook Security/Application Panel

LifeBook Security/ Application Panel

A unique feature of your LifeBook notebook is the Security/Application Panel that allows you to secure your notebook from unauthorized use. The Security/Application Panel also allows you to launch applications with the touch of a button when your system is on.

If the security system is activated, upon starting your notebook or resuming from suspend mode the security system requires you to enter a password code using the buttons on the Security/Application Panel. After entering a correct password, your notebook resumes system operation. (Figure 2-20)

SETTING UP YOUR LIFEBOOK SECURITY PANEL

When you receive your LifeBook notebook, the security panel application is pre-installed without any passwords. The following sections provide detailed information on your security panel, and how to set, change or remove passwords.

Numbered Buttons

Use these buttons to enter your password. (Figure 2-20)

Enter Button

After entering the button strokes, push this button to enter the password into the LifeBook notebook. (Figure 2-20)

PASSWORDS

The user and supervisor password may be set on this notebook. A supervisor password is typically the same for all LifeBook notebooks in a working group, office, or company to allow for system management. Individual LifeBook notebooks in a group environment should not

use a common password. A password consists of one to five button strokes plus the enter button. A valid stroke consists of pushing one or up to four buttons simultaneously. The following are valid button strokes:

- Pushing [4] by itself
- Pushing [2] and [3] at the same time
- Pushing [1], [2], and [4] at the same time
- Pushing [1], [2], [3], and [4] at the same time

The following are valid passwords. The numbers within braces ({ }) are button strokes using more than one button.

- { [2]+[3] }, [1], [enter]
- [4], [enter]
- { [1]+[3] }, { [2]+[3]+[4] }, [1], [4], [2], [enter]

Setting Passwords

When shipped from the factory, no passwords are set. You have a choice of having no password or setting a supervisor and user password. You must set the supervisor password before the user password.

POINTS

- The purpose of supervisor password is to be able to bypass the user password in case the user password is forgotten. The supervisor password alone will not lock the system.
- You have to set both the supervisor and user passwords for the security panel to work.

Setting Supervisor Password

You must have set a supervisor password before setting any user passwords. The supervisor password can bypass the user password.

1. Go to the **Start** menu.
2. Click on **Run**.

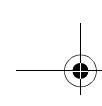

- Type in:
C:\Program Files\Fujitsu\
Security Panel Application\
Supervisor\FJSECS.EXE,
then press [Enter]
- Follow the on-screen instructions to set the Supervisor password.

Setting User Password

- Go to the Start menu.
- Click on Programs.
- Click on Security Panel Application and Set User Password.
- Follow the on-screen instructions to set the user password.



POINT

You may change or remove the supervisor or user password by repeating the steps defined above.

OPERATING YOUR LIFEBOOK SECURITY/ APPLICATION PANEL

The security lock feature is in effect both when the system resumes from Off or suspend state. You always need to push the Suspend/Resume button to input the user password. Your system will not begin the boot sequence without entering your supervisor/user password.

From Off State

- Turn on your system.
- When the Security Indicator flashes, enter the password and press Enter button.
For example, if the password is 22222,
Press Button Number 2 five times and press Enter button.
The LifeBook notebook will boot to normal operation.

From Suspend State

- Press your Power/Suspend/Resume button.
- When the Security Indicator flashes, enter the password and press Enter button.
The notebook should resume normal operation.

Incorrect Password Entry

If an invalid supervisor or user password is entered three times in succession, the system will "beep" for about one minute. If a valid password is entered within a minute (while system beeps), the beeping will stop and the note-

book will resume normal operation. If no password (or an invalid one) is entered while the system beeps, the system will return to its previous locked state (suspend or off) and the Security Indicator will go off. To reactivate the notebook after a password failure, you must press the Power/Suspend/Resume button, then enter a correct password.



POINT

Remember the user password you specified on the Security Panel Application. If you forget the password you will not be able to use your computer. The supervisor password can override the user password.

PRECAUTIONS

Opening and Closing the Cover

Closing the cover automatically places the notebook into suspend mode. Opening the cover does not automatically place the notebook into normal operation. Instead, you must enter the proper security password after pushing the Power/Suspend/Resume button.

Low Battery Operations

If your LifeBook notebook has low battery, pushing the Power/Suspend/Resume button only turns on the Security Indicator. Your notebook does not unlock, the Security Indicator turns off after one minute. To resume normal operation, first attach a power supply to the notebook. Then you may unlock the notebook.

UNINSTALLING THE SECURITY PANEL APPLICATION

You have two options when uninstalling the security panel application:

- Uninstall the security panel application software. This will disable all security feature.
- Uninstall the security panel application with password still active. This will not allow any changes to the password.

Uninstalling the Security Panel Application Software

Remove passwords when User wants no password protection whatsoever and doesn't want to give anybody the utility to set a password on their computer. In this case, if passwords (supervisor, user, or both) are set, the passwords must first be cleared BEFORE removing the application. To clear passwords, follow same procedure in SETTING PASSWORD CODES except this time, select REMOVE, enter current password then click Next. When asked to confirm select Yes.

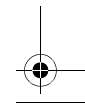
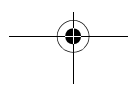
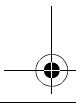
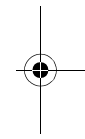
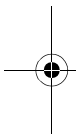

Removing Security Panel Application with Passwords Still Active

Using this feature will not allow any changes to the password.



POINT

Removing the applications does not remove the password. It simply removes the utility to change/add/remove passwords. To change your password you must reinstall the application.

User:

1. Go to **Start Menu**, Click on **Control Panel**.
2. Open **Add/Remove Programs Properties** in the Control Panel.
3. Select the **Security Panel Application** in the list, and click **Add/Remove**.
4. When the **Confirm File Deletion** box appears, click **Yes**.

Supervisor:

1. Go to **Start Menu**, Click on **Control Panel**.
2. Open **Add/Remove Programs Properties** in the Control Panel.
3. Select the **Security Panel Application for Supervisor** in the list, and click **Add/Remove**.
4. When the **Confirm File Deletion** box appears, click **Yes**.

Reinstalling the Security/Application Panel

To reinstall supervisor or user security application, you will need your Drivers and Applications CD. The **Utilities\Security Application Panel** folder contains two separate folders: **Supervisor** and **User**. The setup files for supervisor and user security applications are contained in those folders.

1. Go to the **Utilities\Security Application Panel\Supervisor** folder on the CD and double-click the **setups.exe** file. The **Installing Security Panel Application** window will appear. Follow the instructions on the screen.
2. Go to the **Utilities\Security Application Panel\User** folder on the CD and double-click the **setup.exe** file. The **Installing Security Panel Application** window will appear. Follow the instructions on the screen.

Supervisor and user passwords can be set via Windows software using the **FJSECS.exe** and **FJSECU.exe** files, respectively. **FJSECU.exe** for the user password cannot run without first setting a supervisor password. You need to run **FJSECS.exe** first to set the supervisor password. Follow instructions under **Setting Passwords** on page 20.

If you forget both passwords, please contact Fujitsu PC Corporation Service and Support at 1-800-8FUJITSU (1-800-838-5487). Fujitsu PC Corporation charges a service fee for unlocking a password restricted LifeBook notebook. When calling please have a valid credit card and provide proof of ownership. You will then be given instructions on where to ship your notebook.

LAUNCHING APPLICATIONS WITH THE SECURITY/APPLICATION PANEL

The security panel also enables you to launch applications with the touch of a button when your system is on. Pressing any of the buttons will launch a user-defined application. Your notebook is pre-installed with software utilities that let you operate and configure your LifeBook Security /Application Panel. These utilities are found in the Start menu, under Settings -> Control Panel -> Application Panel. (For Windows XP users, go to Start -> Control Panel -> Other Control Panel Settings -> Application Panel. They include two Application Panel Setup tabs, E-mail Setup, and Internet Setup.

Configuring your LifeBook Application Panel

When you start Windows, the LifeBook Application Panel is automatically activated. An icon resembling a finger pressing a button will appear on the system tray (the indented portion of the status bar where the clock is displayed). When you see this icon you will know that LifeBook Application Panel is active.

As an application launcher, the LifeBook Application Panel is very flexible, giving you a variety of options. To set up the Panel to best suit your needs, we have provided the Application Panel Setup utility that quickly and easily helps you make the most of this valuable feature.

To configure your LifeBook Application Panel with Application Panel Setup:

1. Click on **Start**.
2. Click on **Programs**.
3. Click on **LifeBook Application Panel**.
4. Click on **Application Panel Setup**.

The Application Panel Setup utility will appear. There are tabs that correspond to the application buttons on the LifeBook Application Panel. When you receive your notebook, these buttons are pre-configured to launch specific programs, as referenced in Chapter 7 of this document.



POINT

The tabs in Application Panel Setup may not be in the same order as the buttons on your LifeBook notebook, please select the tab you wish to change carefully.



To change an application associated with the Application buttons, click on the tab for the button you would like to reconfigure – for example, Application A. Click on Browse from Start Menu, scroll down the list of applications, click on the application you wish to launch with this button, and then click OK. The button will now launch the new application.

The Internet tab is different. It comes set to launch your Windows default Internet browser (Internet Explorer), unless you have changed this in Windows. In order to reconfigure it to launch another program follow these easy steps:

1. Click on **Other** from the Internet browser box.
2. Click on **Browse** from Start Menu.
3. Scroll down the list of applications, and then click on the application you wish to launch with this button.
4. Click **OK**.

The button will now launch the new application. If you want to return to launching your Windows default Internet browser with this button, you need only click on “Default Internet Browser” from the Internet browser box. Be aware that you will erase the settings for the “other application”. If you wish to go back to launching the “other application” from this button, you will need to reconfigure it as described above.



POINT

If your system has dedicated one of the application launcher buttons to be an Internet launcher, the button can still be configured to launch any application you wish, not just an Internet browser.

When you have finished with Application Panel Setup click OK, and the new settings will take effect. You can reconfigure your LifeBook Application Panel as often as you like.

Deactivating and Activating the LifeBook Application Panel

To deactivate the LifeBook Application Panel, follow these easy steps:

1. Click on **Start**.
2. Click on **Programs**.
3. Click on **LifeBook Application Panel**.
4. Click on **Deactivate Panel**.

To reactivate, follow the same procedure, except for step 4. Click on **Activate Panel** instead.



POINT

Every time you start Windows the LifeBook Application Panel is activated, even if you deactivated it before you shut down.

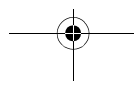
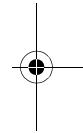
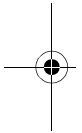

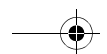
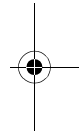
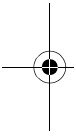
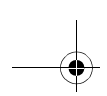

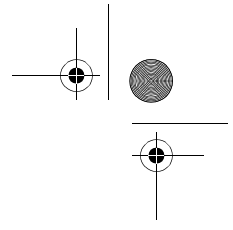
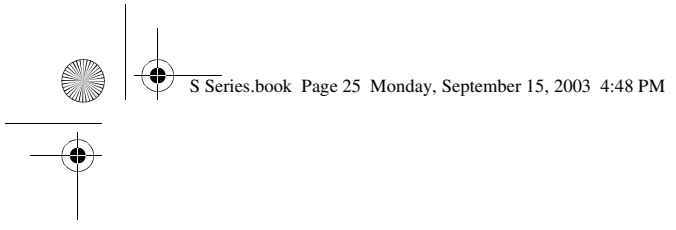

3 Getting Started

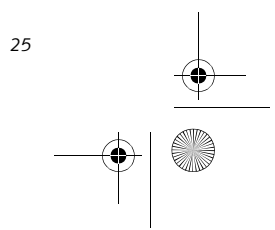
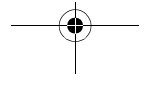
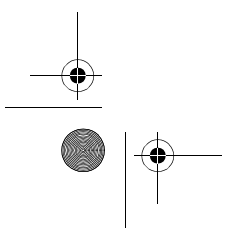
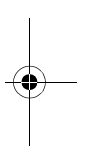
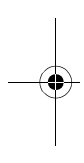

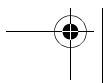
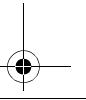
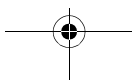
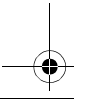
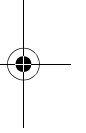
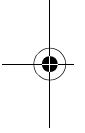
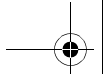

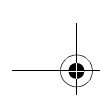

Getting Started

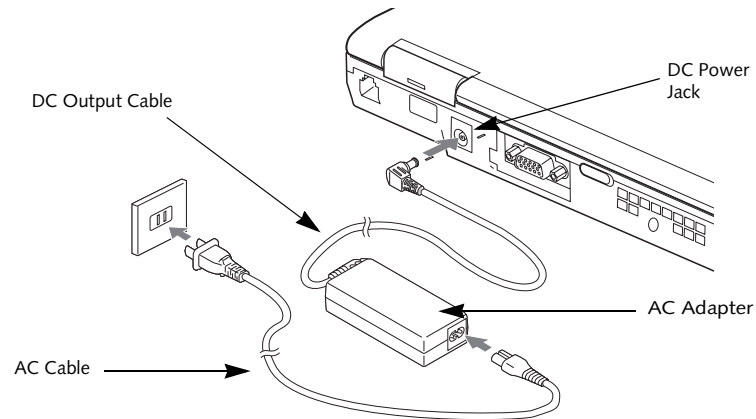

Figure 3-1 Connecting the AC Adapter

Power Sources

Your Fujitsu LifeBook notebook has three possible power sources: a primary Lithium ion battery, an AC adapter or an optional Auto/Airline adapter.

CONNECTING THE POWER ADAPTERS

The AC adapter or optional Auto/Airline adapter provides power for operating your notebook and charging the batteries.

Connecting the AC Adapter

1. Plug the DC output cable into the DC power jack of your LifeBook notebook.
2. Plug the AC adapter into an AC electrical outlet.
(Figure 3-1)

Connecting the Optional Auto/Airline Adapter

1. Plug the DC output cable into the DC power jack on your notebook.

2. Plug the Auto/Airline adapter into the cigarette lighter of an automobile with the ignition key in the On or Accessories position.
OR
3. Plug the Auto/Airline adapter into the DC power jack on an airplane seat.

Switching from AC Adapter Power or the Auto/Airline Adapter to Battery Power

1. Be sure that you have at least one charged battery installed.
2. Remove the AC adapter or the Auto/Airline adapter.

POINT

The Lithium ion battery is not charged upon purchase. Initially, you will need to connect either the AC adapter or the Auto/Airline adapter to use your notebook.

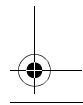
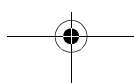
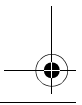
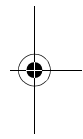
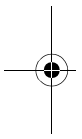

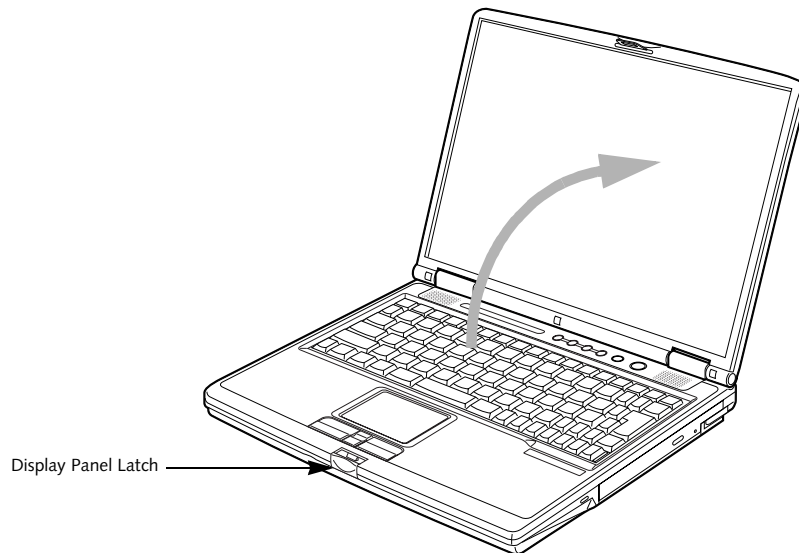

Figure 3-2 Opening the Display Panel

Display Panel

Your Fujitsu LifeBook notebook contains a display panel that is backlit for easier viewing in bright environments and maintains top resolution through the use of active-matrix technology.

OPENING THE DISPLAY PANEL

1. Press the Display Panel latch. This releases the locking mechanism and raises the display slightly.
2. Lift the display backwards, being careful not to touch the screen, until it is at a comfortable viewing angle. (Figure 3-2)

ADJUSTING DISPLAY PANEL BRIGHTNESS

Once you have turned on your LifeBook notebook, you may want to adjust the brightness level of the screen to a more comfortable viewing level. There are two ways to adjust the brightness, by using the keyboard or the power management utility.

Using the Keyboard

Adjusting the brightness using the keyboard changes the setting only temporarily.

- [Fn+F6]: Pressing repeatedly will lower the brightness of your display.
- [Fn+F7]: Pressing repeatedly will increase the brightness of the display.

POINT

When using AC power your brightness setting is set to its highest level by default. When using battery power your brightness setting is set to approximately mid-level by default.

Using the Power Management Utility (Windows 2000 only)

Adjusting the brightness using the Power Management changes the setting permanently.

1. Double-click the BatteryAid icon  in the lower right corner of your display. This will open the BatteryAid Properties dialog box.
2. Select the Power Control tab and adjust your LCD Backlighting to the desired level.
3. Click **OK** or **Apply** to permanently change the settings.

You may need to readjust the brightness level periodically depending on your operating environment.

POINT

The higher the brightness level, the more power the notebook will consume and the faster your batteries will discharge. For maximum battery life, make sure that the brightness is set as low as possible.

CLOSING THE DISPLAY PANEL

1. Holding the edge of your display panel, pull it forward until it is flush with the body of your LifeBook notebook.
2. Push down until you hear a click. This will engage the locking mechanism and prevent your display panel from opening unexpectedly.

Starting Your LifeBook Notebook

POWER ON

Power/Suspend/Resume Button

The Power/Suspend/Resume button is used to turn on your LifeBook notebook from its off state. Once you have connected your AC adapter or charged the internal Lithium ion battery, you can power on your LifeBook notebook. (See figure 2-4 on page 6 for location)

POINT

When you turn on your LifeBook notebook be sure you have a power source. This means that at least one battery is installed and charged, or that the AC or Auto/Airline adapter is connected and has power.

To turn on your LifeBook notebook from its off state, press the Power/Suspend/Resume button, located above the keyboard. When you are done working you can either leave your LifeBook notebook in Suspend mode, (See *Suspend Mode on page 32 for more information*), or you can turn it off (See *Power Off on page 33 for more information*).

CAUTION

Do not carry your LifeBook notebook around with the power on or subject it to shocks or vibration, as you risk damaging your notebook.

When you power on your LifeBook, it will perform a Power On Self Test (POST) to check the internal parts and configuration for correct functionality. If a fault is found, your LifeBook notebook will emit an audio warning and/or an error message will be displayed. (See *Power On Self Test Messages on page 64 for more information*) Depending on the nature of the problem, you may be able to continue by starting the operating system or by entering the BIOS setup utility and revising the settings.

After satisfactory completion of the Power On Self Test (POST), your notebook will load your operating system.

POINT

Never turn off your LifeBook notebook during the Power On Self Test (POST) or it will cause an error message to be displayed when you turn your LifeBook notebook on the next time. (See *Power On Self Test Messages on page 64 for more information*)

BOOT SEQUENCE

The procedure for starting up your notebook is called the Bootup sequence and involves your notebook's BIOS. When your LifeBook notebook is first turned on, the main system memory is empty, and it needs to find instructions to start up your notebook. This information is in the BIOS program. Each time you power up or restart your notebook, it goes through a boot sequence which displays a Fujitsu logo until your operating system is loaded. During booting, your notebook is performing a standard boot sequence including a Power On Self Test (POST). If the sequence is completed without a failure and without a request for the BIOS Setup Utility, the system displays the operating system's opening screen.

The boot sequence is executed when:

- You turn on the power to your LifeBook notebook.
- You restart your notebook from the Windows Shut Down dialog box.
- The software initiates a system restart. Example: When you install a new application.
- You reset the system by pressing [CTRL+ALT+DEL].

BIOS SETUP UTILITY

The BIOS Setup Utility is a program that sets up the operating environment for your LifeBook notebook. Your BIOS is set at the factory for normal operating conditions, therefore there is no need to set or change the BIOS' environment to operate your notebook.

The BIOS Setup Utility configures:

- Device control feature parameters, such as changing I/O addresses and boot devices.
- System Data Security feature parameters, such as passwords.

Entering the BIOS Setup Utility

To enter the BIOS Setup Utility do the following:

1. Turn on or restart your LifeBook notebook.
2. Press the [F2] key once the Fujitsu logo appears on the screen. This will open the main menu of the BIOS Setup Utility with the current settings displayed.
3. Press the [RIGHT ARROW] or [LEFT ARROW] key to scroll through the other setup menus to review or alter the current settings.

BIOS Guide

A guide to your notebook's BIOS is available online. Please visit our service and support Web site at www.fujitsupc.com. Once there, select Support, then select Notebooks under User's Guides. Select LifeBook BIOS Guides from the pull-down menu for your LifeBook series. If you are unsure of your notebook's BIOS number, refer to your packing slip.

 **POINT**

If your data security settings require it, you may be asked for a password before the BIOS main menu will appear.

BOOTING THE SYSTEM

We strongly recommend that you do not attach any external devices and do not put a DVD/CD in any drive until you have gone through the initial power on sequence.

When you turn on your LifeBook notebook for the first time, it will display a Fujitsu logo on the screen. If you do nothing the system will load the operating system, and then the Windows Welcome will begin.

Designed to accommodate the needs of users in many different countries, Windows needs to be configured the first time you use it. Windows has three parts:

- **Getting Started:** You have the opportunity to enter custom information for your configuration file and setup your modem so that your LifeBook notebook will be prepared to dial out.
- **Registration:** Easy online registration for Windows with Microsoft, and for your LifeBook notebook with Fujitsu.
- **Windows License Agreement and Final Settings:** You have the opportunity to review the Windows.

Getting Started

Read the instructions on the screens carefully and fill in the information as directed. You will be asked for such items as the language you wish to use, the country in which you live, your first and last name, and about how you dial out from where you will be using your notebook. For the modem settings, enter your current location information where you will be using your LifeBook notebook. If you are not connected to a phone line and plan to register at a later time, you may click the **Skip** button, and you will go directly to the condition of use page.

 **POINT**

Make sure you have connected a phone line to your modem before you use E-Registration.

Once you have set up your notebook to dial out, Windows will make a free telephone call which will test these settings. If the call is unsuccessful, you will be returned to the phone settings page where you may try to fix them. If you are unable to fix the settings please contact Fujitsu Service and Support. (See *Fujitsu Contact*

Information on page 1 for more information) If you would simply like to move on, and register at a later time, you may click the **Skip** button, and you will go directly to the Condition of Use page.

Registration

If your connection is successful, you will go to the Registration Confirmation page. On this page simply enter the requested information, and then check the box at the bottom to register your copy of Windows with Microsoft. Once you have finished, click the **Next** button to continue.

 **POINT**

If you do not register at this time you can do it later simply by double-clicking on the **LifeBook Registration** icon on your desktop and following the instructions.

You will then go through the Fujitsu registration process. Follow the instructions on the screens, and enter all of the necessary information. Be as specific as possible so that if you need help the service and support team will be able to serve you better.

Final Settings

The first part of your final settings is the Windows End User License Agreement. Read the agreement carefully. When you finish reading you must accept or reject the terms of the agreement and then click on the **Next** button.

 **POINT**

If you reject the terms of the license agreement you will be asked to review the license agreement for information on returning to Windows or to shut down your LifeBook notebook.

WINDOWS PRODUCT ACTIVATION (WINDOWS XP ONLY)

If your system has Windows XP as an operating system, it has already been pre-installed and pre-activated when you receive the system.

In the event you need to re-install Windows XP (e.g., after making significant configuration changes), it may be necessary to reactivate the operating system. To do so, use the following information.

- After re-installing Windows XP, you have thirty days to activate it. Product activation ensures that you are the authorized owner of the Windows XP operating system.
- Until you activate the product, you will be prompted whenever you turn on the system that activation is required. Follow the on-screen directions to activate your operating system. The product only needs to be

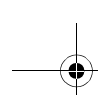

Getting Started

activated once, unless significant hardware changes are made to your system.

- Note that Product Activation and Registration are not the same thing. Registration is optional, whereas Product Activation is a required procedure.

REGISTERING YOUR LIFEBOOK NOTEBOOK

What are the benefits of registering?

You will receive an identification label for your LifeBook notebook, which, if your notebook is ever lost, may help in getting it returned to you. You also receive technical support access and useful product mailings. Proof of purchase is not required if you register within 30 days of your purchase.

How do I register?

To register, visit our Web site at:
www.fujitsupc.com/support

INSTALLING CLICK ME!

The first time you boot up your system, you will see an icon called Click Me!. (The icon is located on the desktop for Windows 2000 systems; it is located in the Start menu for Windows XP systems). When you click the Click Me! icon, your system will automatically build the icon tray in the bottom right of the screen. These icons provide links to utilities that you will frequently access.

Click Me! will install additional system utilities to maximize the performance of your system.

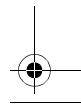
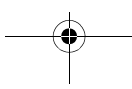
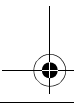
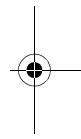
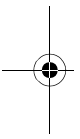

Power Management

Your Fujitsu LifeBook notebook has many options and features for conserving battery power. Some of these features are automatic and need no user intervention, such as those for the internal modem. However, others depend on the parameters you set to best suit your operating conditions, such as those for the display brightness. Internal power management for your notebook may be controlled from settings made in your operating system, pre-bundled power management application, or from settings made in BIOS setup utility.

Besides the options available for conserving battery power, there are also some things that you can do to prevent your battery from running down as quickly. For example, you can create an appropriate power saving profile, put your notebook into Suspend mode when it is not performing an operation, and you can limit the use of high power devices. As with all mobile, battery powered computers, there is a trade-off between performance and power savings.

POWER/SUSPEND/RESUME BUTTON

When your LifeBook notebook is active, the Power/Suspend/Resume button can be used to manually put your notebook into Suspend mode. Push the Power/Suspend/Resume button when your notebook is active, but not actively accessing anything, and immediately release the button. You will hear two short beeps and your system will enter Suspend mode. (See figure 2-4 on page 6 for location)

If your LifeBook is suspended, pushing the Power/Suspend/Resume button returns your notebook to active operation. You can tell whether the system is Suspended by looking at the Power indicator. (See figure 2-4 on page 6) If the indicator is visible and not flashing, your notebook is fully operational. If the indicator is visible *and* flashing, your notebook is in Suspend mode. If the indicator is not visible, the power is off or your notebook is in Hibernation mode. (See *Hibernation Feature*)

SUSPEND MODE

Suspend or Standby mode in Windows saves the contents of your LifeBook notebook's system memory during periods of inactivity by maintaining power to critical parts. This mode will turn off the CPU, the display, the hard drive, and all of the other internal components except those necessary to maintain system memory and allow for restarting. Your notebook can be put in Suspend mode by:

- Pressing the Power/Suspend/Resume button when your system is turned on.
- Selecting Standby from the Windows Shut Down menu.
- Timing out from lack of activity.

- Allowing the battery to reach the Dead Battery Warning condition.

Your notebook's system memory typically stores the file on which you are working, open application information, and any other data required to support operations in progress. When you resume operation from Suspend mode, your notebook will return to the point where it left off. You must use the Power/Suspend/Resume button to resume operation, and there must be an adequate power source available, or your notebook will not resume.

POINTS

- If you are running your LifeBook notebook on battery power, be aware that the battery continues to discharge while your notebook is in Suspend mode, though not as fast as when fully operational.
- Disabling the Power/Suspend/Resume button prevents it from being used to put your LifeBook notebook in Suspend or Hibernation (Save-to-Disk) mode. The resume function of the button cannot be disabled.
- The Suspend or Hibernation (Save-to-Disk) mode should not be used with certain PC Cards. Check your PC Card documentation for more information. When PC Cards or external devices are in use, Hibernation (Save-to-Disk) mode cannot return to the exact state prior to suspension, because all of the peripheral devices will be re-initialized when the system restarts.
- If your LifeBook notebook is actively accessing information when you enter the Suspend or Hibernation (Save-to-Disk) mode, changes to open files are not lost. The files are left open and memory is kept active during Suspend mode or the memory is transferred to the internal hard drive during Hibernation mode.
- The main advantage of using the Hibernation (Save-to-Disk) function is that power is not required to maintain your data. This is particularly important if you will be leaving your LifeBook notebook in a suspended state for a prolonged period of time. The drawback of using Hibernation mode is that it lengthens the power down and power up sequences and resets peripheral devices.

HIBERNATION (SAVE-TO-DISK) FEATURE

The Hibernation feature saves the contents of your LifeBook notebook's system memory to the hard drive as a part of the Suspend/Resume mode. You can enable or disable this feature.

Enable or Disable the Hibernation Feature

The default settings is not enabled. To enable or disable the Hibernation feature follow these easy steps:

1. From the **Start** menu, select **Settings**, and then select **Control Panel**.

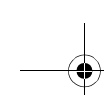

Getting Started

2. From the **Control Panel** select **Power Options**.
3. Select the **Hibernation** tab. Select the box to enable or disable this feature.

Using the Hibernation Feature

1. From the **Start** menu, select **Settings**, and then select **Control Panel**.
2. From the **Control Panel** select **Power Options**.
3. Select the **Advanced** tab. Select **Hibernate** from the pull down menu for Power buttons.

DISPLAY TIMEOUT

The Video Timeout is one of the power management parameters. This feature saves power by turning off the display if there is no keyboard or pointer activity for the user selected timeout period. Any keyboard or pointer activity will cause the display to restart automatically. This feature is independent of the Power/Suspend/Resume button and can be enabled and disabled in Windows and BIOS setup utility. (See *BIOS Setup Utility on page 29 for more information*)

HARD DISK TIMEOUT

The Hard Disk Timeout is another one of the power management parameters. This feature saves power by turning off the hard drive if there is no hard drive activity for the user selected timeout period. Any attempt to access the hard drive will cause it to restart automatically. This feature is independent of the Power/Suspend/Resume button and can be enabled and disabled in Windows and BIOS setup utility. (See *BIOS Setup Utility on page 29 for more information*)

WINDOWS POWER MANAGEMENT

Power Management

The Power Management icon located in the Windows Control Panel allows you to configure some power management settings. For example, you can use Power Management to set the timeout values for turning off the display and hard disks whether you are running the notebook on battery power or one of the adapters. The settings may also be changed in the BIOS. (See *BIOS Setup Utility on page 29 for more information*)

RESTARTING THE SYSTEM

If your system is on and you need to restart it, be sure that you use the following procedure.

1. Click the **Start** button, and then click **Shut Down**.
2. Select the **Restart** option from within the Windows Shut Down dialog box.
3. Click **OK** to restart your notebook. Your notebook will shut down and then reboot.

POINT

Turning off your notebook without exiting Windows, or turning it on within 10 seconds of being shut off may cause an error when you start the next time.

POWER OFF

Before turning off the power, check that the Hard Drive, DVD, CD-ROM, CD-RW, PC Card and Floppy Disk indicators are all Off. (See *figure 2-4 on page 6*) If you power-off while accessing a disk or PC Card there is a risk of data loss. To ensure that the notebook shuts down without error, use the Windows shutdown procedure.

CAUTION

Be sure to close all files, exit all applications, and shut down your operating system prior to turning off the power. If files are open when you turn the power off, you will lose any changes that have not been saved, and may cause disk errors.

Using the correct procedure to shut down from Windows allows your notebook to complete its operations and turn off power in the proper sequence to avoid errors. The proper sequence is:

1. Click the **Start** button, and then click **Shut Down** or **Turn Off Computer**.
2. Select the **Shut Down** option from within the Windows Shut Down dialog box.
3. Click **OK** to shut down your notebook.

If you are going to store your notebook for a month or more see Care and Maintenance Section.

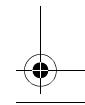
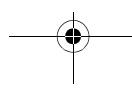
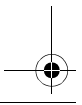
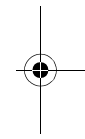
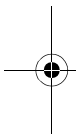

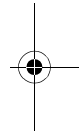
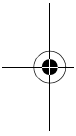
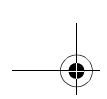

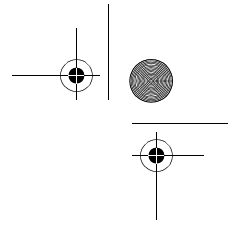
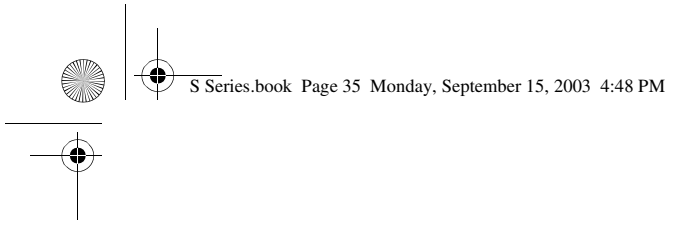

4

User-Installable Features

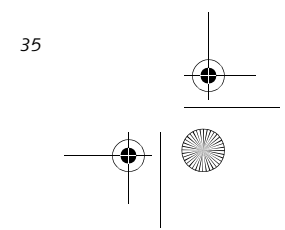
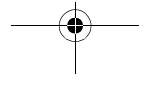
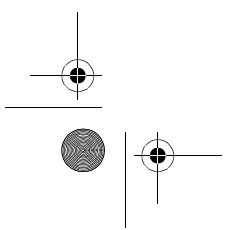
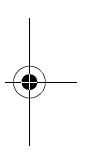
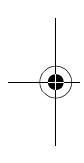

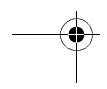
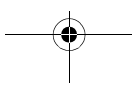
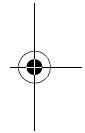
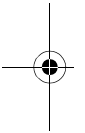
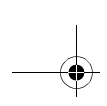

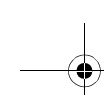

User Installable Features

Lithium ion Battery

Your LifeBook notebook has a Lithium ion battery that provides power for operating your notebook when no external power source is available. The battery is durable and long lasting, but should not be exposed to extreme temperatures, high voltages, chemicals or other hazards.

The Lithium ion battery operating time may become shorter if it is used under the following conditions:

- When used at temperatures that exceeds a low of 5°C or a high of 35°C. Extreme temperatures not only reduce charging efficiency, but can also cause battery deterioration. The Charging icon on the Status Indicator panel will flash when you try to charge a battery that is outside its operating temperature range. (See *Battery Charging Indicators on page 12 for more information*)
- When using a high current device such as a modem, CD-ROM drive, DVD drive, DVD/CD-RW combo drive, or the hard drive, using the AC adapter will conserve your battery life.



CAUTION

Do not leave a faulty battery in your LifeBook notebook. It may damage your AC adapter, optional Auto/Airline adapter, another battery or your notebook itself. It may also prevent operation of your notebook by draining all available current into the bad battery.



POINTS

- Actual battery life will vary based on screen brightness, applications, features, power management settings, battery condition and other customer preferences. CD-ROM drive, DVD drive, DVD/CD-RW drive combo, or hard drive usage may also have a significant impact on battery life. The battery charging capacity is reduced as the battery ages. If your battery is running low quickly, you should replace it with a new one.
- Under federal, state, or local law it may be illegal to dispose of batteries by putting them in the trash. Please take care of our environment and dispose of batteries properly. Check with your local government authority for details regarding recycling or disposing of old batteries. If you cannot find this information elsewhere, contact your support representative at 1-800-8FUJITSU (1-800-838-5487)

RECHARGING THE BATTERIES

If you want to know the condition of the primary Lithium ion battery, check the Battery Level indicator located on the Status Indicator panel. The indicator changes as the battery level changes.

The Lithium ion battery is recharged internally using the AC adapter or Auto/Airline adapter. To recharge the battery make sure the battery that needs to be charged is installed in your LifeBook notebook and connect the AC or Auto/Airline adapter.



POINT

Make sure that the Battery Charging indicator and the percentage charge is shown inside the Battery Level icon on the Status Indicator Panel.

There is no memory effect on the Lithium ion battery therefore you do not need to discharge the battery completely before recharging. The charge times will be significantly longer if your notebook is in use while the battery is charging. If you want to charge the battery more quickly, put your notebook into Suspend mode, or turn it off while the adapter is charging the battery. (See *Power Management on page 32 for more information on Suspend mode and shutdown procedure*)



POINT

Using heavy current devices such as Modem or frequent DVD/CD-RW/CD-ROM accesses may prevent charging completely.

Low Battery State

When the battery is running low, a low battery notification message will appear. If you do not respond to the low battery message, the batteries will continue to discharge until they are too low to operate. When this happens, your notebook will go into Suspend mode. There is no guarantee that your data will be saved once the notebook reaches this point.



CAUTIONS

- Once the low battery notification message appears, you need to save all your active data and put your LifeBook notebook into Suspend mode until you can provide a new power source. You should provide a charged battery, an AC power adapter, or Auto/Airline adapter as soon as possible.
- When you are in Suspend mode there must always be at least one power source active. If you remove all power sources while your LifeBook notebook is in Suspend mode, any data that has not been saved to the hard drive will be lost.

Dead Battery Suspend mode shows on the Status indicator just like the normal Suspend mode. Once your notebook goes into Dead Battery Suspend mode you will be unable to resume operation until you provide

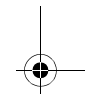
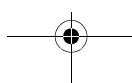
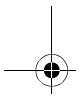
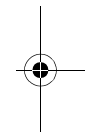
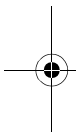

a source of power either from an adapter, or a charged battery. Once you have provided power, you will need to press the Power/Suspend/Resume button to resume operation. In the Dead Battery Suspend mode, your data can be maintained for some time, but if a power source is not provided promptly, the Power indicator will stop flashing and go out, meaning that you have lost the data that was not stored. Once you provide power, you can continue to use your notebook while an adapter is charging the battery.

Shorted Batteries

The Status Indicator panel uses a symbol inside the battery outline of the Battery Level indicator to display the operating level available in that battery. (See figure 2-10 on page 11) If this display shows a Shorted Battery, it means that the battery is damaged and must be replaced so it does not damage any other parts of your LifeBook notebook.

REPLACING THE BATTERY

With the purchase of an additional battery, you can have a fully charged spare to swap with one that is not charged. There are two ways to swap batteries, cold-swapping and hot-swapping:

Cold-swapping Batteries

To cold-swap batteries in your battery bay follow these easy steps: (Figure 4-1)

1. Have a charged battery ready to install.
2. Shut down your notebook and disconnect the AC adapter.
3. Unlock the battery bay using the lock button.
4. Slide the battery bay release button to open the bay.
5. Remove the battery from the bay.
6. Slide the new battery into the bay.
7. Close the bay and slide the battery bay release button back.
8. Plug in the AC adapter and turn the power on.

Hot-swapping Batteries

To hot-swap batteries in your battery bay follow these easy steps: (Figure 4-1)

CAUTION

Be sure to plug in an AC Adapter prior to removing the battery. There is no bridge battery present to support the system while the battery is being replaced. If you do not use an AC Adapter you will lose any unsaved files.

1. Plug an AC Adapter into the system and connect it to a power outlet.

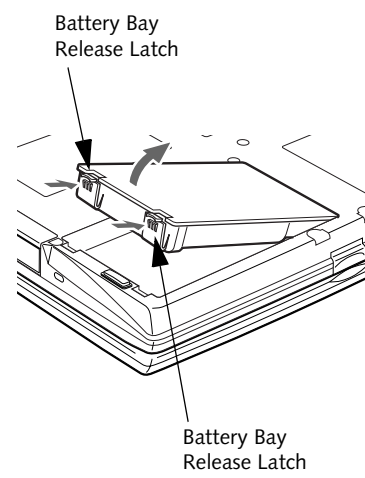

Figure 4-1. Removing a Battery

2. Press the two battery bay release latches to release the battery (Figure 4-1).
3. Remove the battery from the bay.
4. Slide the new battery into the bay (Figure 4-2).

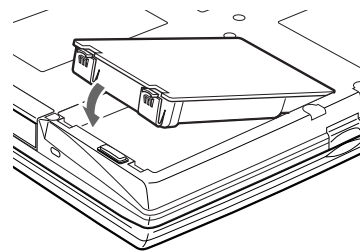

Figure 4-2. Installing a Battery

5. Press the battery down until it clicks into place.

POINT

If the Lithium ion battery connector is not fully seated, you may not be able to use your notebook or charge your battery.

User Installable Features

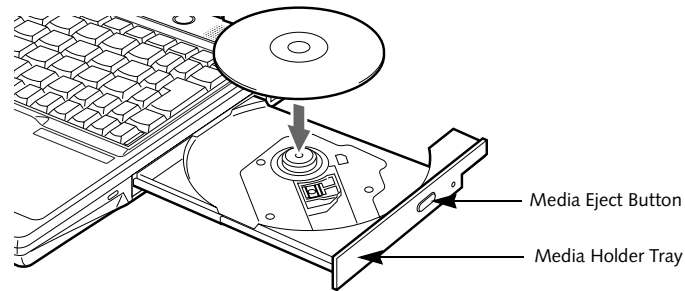

Figure 4-3. Media Player Drive

Media Player Drive

There is a variety of media available to use with your system, depending upon the system configuration you have selected.

DVD-R discs allow you to read DVD files; DVD-R discs hold up to 4.7GB of data. A CD-R disc can only be written to once; CD-RW discs can be written to over and over. CD-R and CD-RW discs hold up to 700MB of data.

Depending upon the configuration of your LifeBook notebook, you may have one of the following drives:

- **DVD/CD-RW combo**
A DVD/CD-RW combo drive allows you to access movie, software, data, or audio DVD/CDs, and to write data onto recordable CD-R and CD-RW discs.
- **DVD**
A DVD player gives you access to movie, software, data, and audio DVD/CDs.
- **CD-ROM**
A CD-ROM drive allows you to access software, data, or audio CDs.

POINT

Install your media player software before first using the DVD, DVD/CD-RW, or CD-ROM media drives. Refer to the applicable readme file on the Driver Applications CD-ROM.

MEDIA PLAYER SOFTWARE

DVD model only: With the media player drive and media player software you can play DVD movies and music CDs on your LifeBook notebook. The media player includes controls which allow you to take full advantage of the features of a DVD movie, as well as standard features such as fast forward, fast reverse, pause, etc.

DVD/CD-RW Combo model only: With the combo drive, you can play DVD movies, read audio CDs, and write data onto recordable CD-R or CD-RW discs.

CD-ROM model only: With the CD-ROM drive, you can read software, audio, or data CD discs.

CAUTIONS

- Do not operate your media player drive unless your LifeBook notebook is sitting on a flat surface. Using a drive when the system is not level may damage the drive or prevent proper operation.
- Prolonged use of the media player drive, such as watching a DVD movie, will substantially reduce your battery life if no other power source is attached.

POINTS

- You should periodically check the Fujitsu web site at www.fujitsupc.com for current updated drivers.
- All LifeBook DVD players are set to play DVD titles with region code number 1 which is specified for the North American market. The region number is a regional restriction code defined by the DVD Forum acting on Hollywood requirements. Different region codes are recorded on video DVD titles for publication in different areas of the world. If the regional code of the DVD player does not match the regional codes on the titles, then playback is impossible.
- You can change the region code on the DVD player using the Properties menu of the DVD software. Note, however, that **you can only change the region code up to four times**. After the fourth change, the last region code entered becomes permanent, and cannot be changed.

LOADING MEDIA ON YOUR DRIVE

To load a disc into your media player drive:

1. Push and release the eject button on the front of the media player drive to open the holder tray. The tray will come out of the LifeBook notebook a short distance.
2. Gently pull the tray out until a media disc can easily be placed in the tray.

CAUTION

There may be a protective sheet in the tray from when it was shipped; please make sure it is removed before operating the drive.

- Place the media into the tray, label side up, with the hole in the center of the disc. Snap the disc onto the raised circle in the center of the tray.
- Gently push the holder tray back in until you hear a click. (Figure 4-4)

POINT

If you have disabled the Auto Insert Notification Function, you will have to start the drive from your desktop, since your LifeBook notebook will not automatically recognize that media has been loaded.

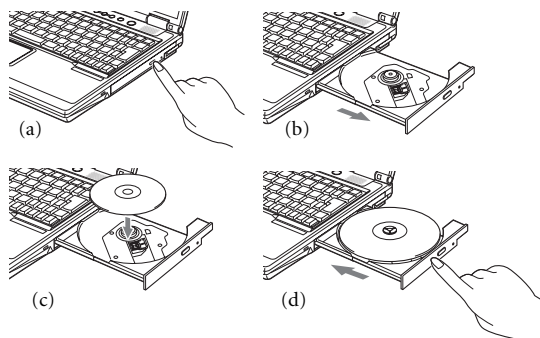

Figure 4-4. Loading/Ejecting Media

REMOVING MEDIA

- Push and release the eject button on the front of the media player drive. This will stop the drive and the holder tray will come out of the LifeBook notebook a short distance.
- Gently pull the tray out until the disc can easily be removed from the tray.
- Carefully remove the media disc from the holder tray.
- Gently push the holder tray back in until you hear a click.

USING THE MEDIA PLAYER SOFTWARE**POINT**

Depending upon its configuration, your system may not have the media player software pre-installed. If it is not installed, reference the documentation that accompanies the media application.

Starting a DVD Movie (DVD Models only)

- Insert the DVD movie into the media player drive of your notebook. If the CD AutoRun feature activates, skip Step 2.
- Windows 2000 only:* From the **Start** menu, select **Programs**, then select **InterVideo WINDVD** and click **InterVideo WINDVD** or double-click on the **InterVideo WINDVD** icon on the desktop. This will launch the DVD movie.
- Windows XP only:* The first time you insert a movie into the DVD/CD-RW tray, you will be prompted to select what you want the system to do when discs are inserted (e.g., start automatically or wait for a prompt). Until you make a selection, you will receive the same prompt whenever you insert a disc.
- Click **OK** to close the About DVD Player Performance dialog box and the movie will begin.

Opening the Media Player Control Panel

With most DVD-ROMs, you have the option of altering how the movie should play and what you wish to view. You can do this by using the media player control panel and the mouse.

- Right-click on the movie screen to open a dropdown menu for options.
- Select **View**, then **Player** for all the controls available. This will open the control panel into the bottom of the screen.

Using the Media Player Control Panel

The media player software allows you to watch the movie much like a VCR player. You have the option to pause, rewind, fast-forward and stop the movie at any point.

- To Pause the movie, click the on-screen **II** button.
- To Rewind the movie, click the **◀◀** button to rewind to a specific portion of the movie, or the **◀** button to return to the opening screen.
- To Fast-forward the movie, click the **▶▶** button to forward to a specific portion of the movie, or the **▶** button to jump to the ending credits.
- To Stop the movie, click the **■** button.

Exiting the Media Player

- Click the **X** located in the upper right corner of the title bar. This will open a media player dialog box.
- Click **Yes** to stop and exit the movie, or **No** to close the media player dialog box and return to the movie.

User Installable Features**USING DOLBY™ HEADPHONE**

The Dolby Headphone utility lets you enjoy multi-channel sound sources, such as movies, with realistic surround sound using your *conventional* stereo headphones.

Dolby Headphone is a signal processing system that enables your stereo headphones to realistically portray the sound of a five-speaker playback system.

POINTS

- Media discs which do not have the Dolby Surround 5:1 symbol will not support Dolby Headphone.
- After making changes to the Dolby Headphone feature and clicking OK, wait at least ten seconds before making another change in order to allow the system to stabilize.

To use the Dolby Headphone feature, perform the following steps:

1. Insert the disc in the media player tray. When you do so, WinDVD will start automatically.
2. Place your cursor over the Fujitsu logo on the WinDVD control panel and click on it. If the disc supports Dolby Surround 5.1, a drop down menu appears.
3. Verify that Dolby headphones is checked on the menu. If you do not want it active, select Disable.

USING MEDIA PLAYER ON BATTERY POWER

Since media player drives consume a lot of power, your overall battery life will be significantly shorter when operating the media player drive continuously (such as watching a DVD movie) than during standard operation. Many movies run-times are longer than your LifeBook notebook can support on a single charged battery. If you are watching a DVD movie on battery power you may need to swap in an additional, charged battery or attach AC power during the movie to view it in its entirety.

POINTS

- Prolonged use of the media player drive, such as watching a DVD movie, will substantially reduce your LifeBook notebook's battery life.
- Many movie run-times are longer than your system can support on a single battery. If you are watching a DVD movie on battery power you may need to swap in an additional, charged battery or attach AC power during the movie to view it in its entirety.
- An additional fully-charged battery is highly recommended if you will be watching DVD movies on battery power. If you don't have an additional battery, you may purchase one either online at www.fujitsupc.com or by calling 1-877-372-3473.

To Watch a Movie on Battery Power:

1. Have an additional full-charged battery or your AC adapter ready for use.
2. Start watching your DVD movie.
3. When the low battery warning occurs, immediately stop the movie and exit the media player.

CAUTION

If you do not stop the media player quickly and the LifeBook notebook attempts to auto-suspend (critical battery low state) the LifeBook notebook will shut down improperly. If this occurs, you will need to perform a hard reset and follow the instruction, if any, presented to you before the system will reboot.

4. Power down your LifeBook notebook and replace the discharged battery with an additional fully-charged battery. If you do not have an additional battery, you may attach AC power as soon as you see the low battery warning.
5. Resume your LifeBook notebook by pressing the Suspend button again. This is not required if you attached AC power without entering suspend mode.
6. Restart your media player, locate and skip to the chapter of the movie you were last watching.
7. Continue watching your DVD movie.

POINT

Some shorter DVD movies may not require you to swap batteries or attach AC power to complete them. However, it is best to be prepared since actual battery life while operating the media player drive cannot be guaranteed.

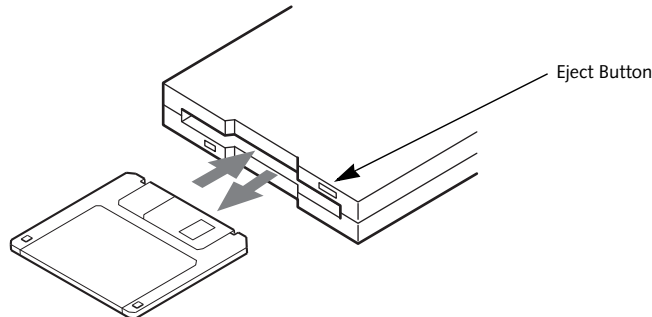

Figure 4-5. Loading/Ejecting a 3.5" Floppy Disk

External USB Floppy Disk Drive

An external USB floppy disk drive is available as an option for your LifeBook notebook. The external floppy disk drive can read and write information on removable 1.44MB and 720KB floppy disks.

POINT

Your LifeBook notebook is preconfigured to boot from a USB floppy drive. Reference the BIOS manual for further information on changing the default boot drive. The BIOS manual can be found on the Fujitsu PC web site: www.FujitsuPC.com, under Support.

LOADING A DISK

To load a disk into your disk drive, follow these easy steps:

1. Orient the disk so that its label is facing upwards and the shutter side is pointing towards the drive. (Figure 4-5)
2. Push the disk into the drive until the Eject button pops out and you hear a click.

POINT

When there is no disk in the drive, the Eject button is flush with your notebook.

EJECTING A DISK

To eject a disk from the disk drive, follow these easy steps:

1. Check that the Floppy Disk Drive Access indicator is inactive.
2. Press the Eject button. This will push your disk partially out of the drive.
3. Remove the disk.

CAUTION

If you eject the disk while the Floppy Disk Drive Access indicator is active, there is a risk of damaging the data on the disk, the disk itself or even the disk drive.

PREPARING A DISK FOR USE

Before you can use a new disk, it needs to be prepared so your LifeBook notebook knows where to store information. This preparation is called formatting or initializing a disk. You will need to format new disks, unless they are preformatted. (Please refer to your operating system manual for step-by-step instructions on formatting a disk)

To prevent accidental erasure of the data stored on a disk, slide the "write protect" tab until a small hole is exposed. This sets the disk into a protected state where nothing can be added or removed. If you want to add or remove data on a protected disk, slide the "write protect" tab to close the small hole. (Figure 4-6)

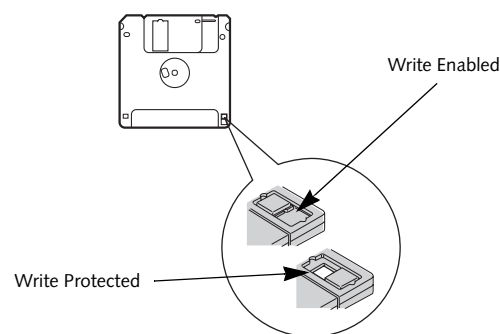

Figure 4-6. Floppy Disk Write Protect

CAUTION

Formatting a floppy disk that already contains data will erase all of the information on the disk.

User Installable Features

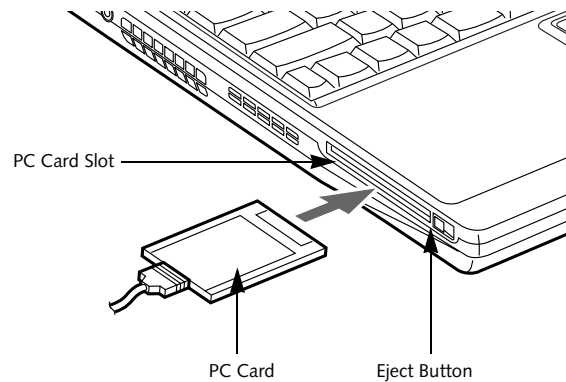

Figure 4-7. Installing/Removing PC Cards

PC Cards

Your Fujitsu LifeBook notebook supports Type I and II PC Cards, which can perform a variety of functions.

Some available PC Cards:

- Fax/data modem cards
- Local area network (LAN) cards
- IDE solid-state disk cards
- SCSI cards
- Smart Card holder
- Other PC Cards that conform to PCMCIA 2.1 or CardBus standards

For further information, refer to the instructions supplied with your PC Card.

INSTALLING PC CARDS

PC Cards are installed in the PC Card slot. To install a PC Card, follow these easy steps: (Figure 4-7)

! WARNINGS

- Installing or removing a PC Card during your LifeBook notebook's shutdown or bootup process may damage the card and/or your notebook.
- Do not insert a PC Card into a slot if there is water or any other substance on the card as you may permanently damage the card, your LifeBook notebook, or both.
- Be sure to orient the card properly before inserting it. Failure to do so could result in damage to the card socket.

1. See your PC Card manual for specific instructions on the installation of your card. Some PC Cards may require your notebook to be Off while installing them.
2. Make sure there is no PC Card currently in the slot. If there is, see Removing PC Cards.

3. Insert your PC Card into the slot, with the product label facing up.
4. Push the card into the slot firmly until it is seated in the opening. You will hear a click and the Eject button will pop away from your notebook.
5. Flip the Eject button towards the rear of your notebook to lock the PC Card.

REMOVING PC CARDS

To remove a PC Card, follow these easy steps:

CAUTION

Windows has a shutdown procedure for PC Cards that must be followed before removing a card. (Please review your operating system manual for the correct procedure). Before removing a PC Card in Windows 2000 Professional, shut down PC Card operation using the Unplug/Eject Hardware icon located on the taskbar.

1. See your PC Card manual for specific instructions on removing your card. Some PC Cards may require your notebook to be in Suspend Mode or Off while removing them.

POINT

If the dialog box states that the device cannot be removed, you must save all of your open files, close any open applications and shut down your notebook.

2. Flip the Eject button towards the front of your notebook until it is fully extended, and then push it in until it is flush with the notebook. This will push the PC Card slightly out of the slot allowing you to remove the card.

CAUTION

If the PC Card has an external connector and cable, do not pull the cable when removing the card.



SMART CARD READER

An embedded Smart Card Reader is provided on your LifeBook notebook. Smart Cards are the same size and shape as credit cards, but they contain an integrated microprocessor chip. The chip can hold a variety of different information, and provides the user with many possible options, such as allowing them to make secure purchases, pay for phone calls, store security information, and provide personal identification and information.

In order to use the embedded Smart Card Reader, you must purchase an optional Smart Card adapter and third-party software for installation into an available Type II PC Card slot.

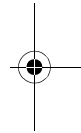
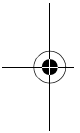

Memory Upgrade Module

Your Fujitsu LifeBook notebook comes with a minimum of 256MB of high speed Double Data Rate Synchronous Dynamic RAM (DDR SDRAM), 266MHz factory installed. To increase your LifeBook notebook's memory capacity, you may install an additional memory upgrade module. The memory upgrade must be a dual-in-line (DIMM) SDRAM module. To ensure 100% compatibility, purchase the SDRAM module only from the Fujitsu web store at www.fujitsupc.com.

CAUTIONS

- Do not remove any screws from the memory upgrade module compartment except the ones specifically shown in the directions for installing and removing the memory upgrade module.
- The memory upgrade module can be severely damaged by electro-static discharge (ESD). Be sure you are properly grounded when handling and installing the module.

INSTALLING MEMORY UPGRADE MODULES

1. Turn off power to your LifeBook notebook and remove any power adapter (AC or auto/airline).
2. Make sure that all the connector covers are closed.
3. Turn the notebook bottom side up, and remove the screws of the memory upgrade module compartment. (Figure 4-8)
4. Remove the cover.

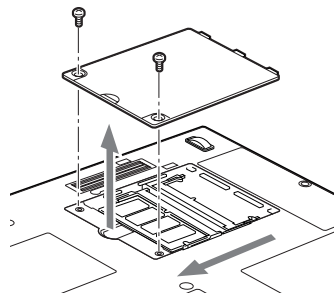

Figure 4-8. Opening the Memory Upgrade Compartment

5. Remove the memory upgrade module from the static guarded sleeve.
6. Align the memory upgrade module with the part side up. Align the connector edge of the memory upgrade module with the connector slot in the compartment.
7. Insert the memory upgrade module at a 45° angle. Press the connector edge of the module firmly down and into the connector until it lodges under the retaining clip. You will hear a click when it is properly in place. (Figure 4-9)

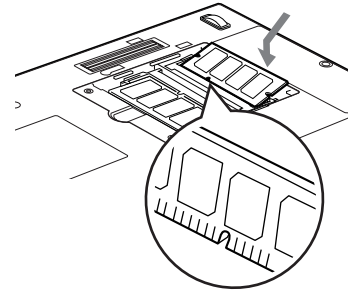

Figure 4-9. Installing a Second Memory Module

8. Replace the cover. (Figure 4-10)
9. Replace the screws.

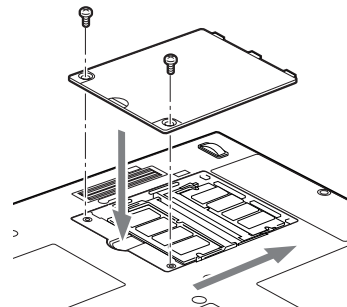

Figure 4-10. Replacing the Memory Compartment Cover

POINT

The memory upgrade module is not something you routinely remove from your notebook. Once it is installed, you can leave it in place unless you want to change system memory capacity.

TO REMOVE A MEMORY UPGRADE MODULE

1. Perform steps 1 through 4 of Installing a Memory Upgrade Module.
2. Pull the clips sideways away from each side of the memory upgrade module at the same time.
3. While holding the clips out, remove the module from the slot by lifting it up and pulling towards the rear of your notebook. (Figure 4-11)

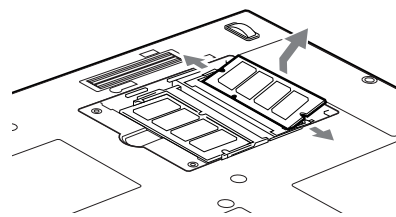

Figure 4-11. Removing a Memory Upgrade Module

4. Store the memory upgrade module in a static guarded sleeve.
5. Replace the cover. (Figure 4-10)
6. Replace the screws.



CHECKING THE MEMORY CAPACITY

Once you have changed the system memory capacity by replacing the installed module with a larger one, be sure to check that your notebook has recognized the change.

Check the memory capacity by clicking [Start] -> Settings -> Control Panel, then double-clicking the System icon. Select the General tab and check the amount of memory under "Computer:".

There may be a variation between the actual memory size and what is displayed. This is due to the fact that your system uses a video graphics chip which dynamically allocates system memory to accelerate graphics

performance. Up to 64 MB of memory is dynamically shared on an as-needed basis using Dynamic Video Memory Technology (DVMT).



If the total memory displayed is incorrect, check that your memory upgrade module is properly installed. *(If the module is properly installed and the capacity is still not correctly recognized, see Troubleshooting on page 55.*

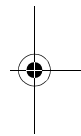
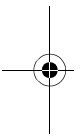

User Installable Features

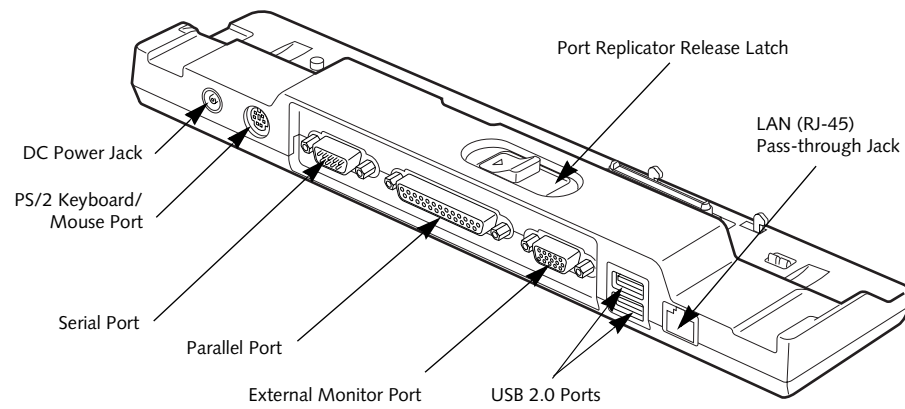

Figure 4-12. Port Replicator back panel

Port Replicator

An optional Port Replicator is available for your Fujitsu LifeBook notebook. The Port Replicator extends the functionality of your notebook by providing ports to connect PS/2 devices, a LAN (RJ-45) cable, USB devices, an external monitor, a parallel device, and a serial device. The Port Replicator connects to the rear panel of your notebook. (See *Device Ports* on page 49 for more information)

BACK PANEL COMPONENTS

The following is a brief description of the optional Port Replicator's back panel components.

LAN (RJ-45) Jack

The LAN port allows you to connect a LAN (RJ-45) cable. Note that when your notebook is connected to the Port Replicator, the LAN port on the system is not accessible; the Port Replicator LAN port is the only one that should be used when it is attached to the system.

PS/2 Keyboard/Mouse Port

The PS/2 keyboard/mouse port allows you to connect external PS/2 devices such as an external PS/2 keyboard or mouse.

USB Ports

There are two USB 2.0 ports on the Port Replicator. The USB ports allow you to connect Universal Serial Bus devices.

USB 2.0 ports allow you to connect any USB 2.0 device for up to 480Mbps transfer rate. USB 2.0 is backward-compatible with USB 1.1 devices.

External Monitor Port

The external monitor port allows you to connect an external VGA or SVGA CRT monitor.

Parallel Port

The parallel port allows you to connect parallel devices. (This is also sometimes referred to as an LPT port.)

Serial Port

The serial port allows you to connect serial (RS-232C) devices. (This is also sometimes referred to as a COM port.)

DC Power Jack

The DC power jack allows you to plug in the AC adapter or the optional Auto/Airline adapter to power your notebook.

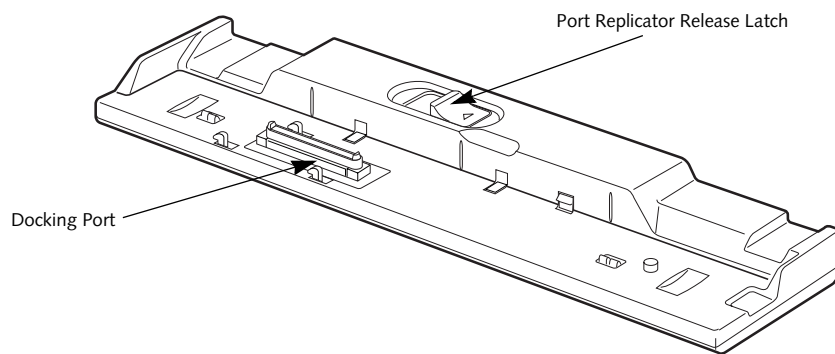

Figure 4-13. Port Replicator front panel

FRONT PANEL COMPONENTS

The following is a brief description of the optional Port Replicator's front panel components.

Docking Port

The docking port connects the optional Port Replicator to your notebook. (Figure 4-13)

Port Replicator Release Latch

Slide the Port Replicator Release button to remove the Port Replicator from your notebook. (Figure 4-13)

CAUTION

Do not hold the system by the Port Replicator. The Port Replicator and/or the system could be damaged if the Port Replicator is used as a handle.

ATTACHING THE PORT REPLICATOR

The Port Replicator can be attached on your notebook while the power is on, while in suspend mode, or while the power is off. To attach the Port Replicator follow these easy steps:

1. Align the Port Replicator connector on the lower surface of your notebook with the connector on top of the Port Replicator.
2. Push your notebook down to connect it to the Port Replicator securely. (Figure 4-14)

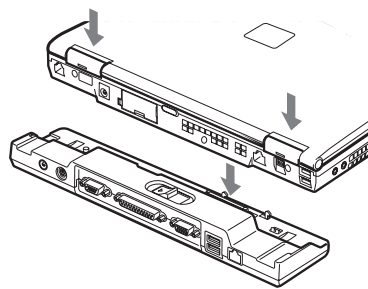

Figure 4-14. Attaching the Port Replicator

DETACHING THE PORT REPLICATOR

The optional Port Replicator can be detached from your notebook while the power is on, while in suspend mode, or while the power is off. To detach the Port Replicator follow these easy steps:

1. Slide the Port Replicator's release button to the right to release the lock. (Figure 4-15)
2. Lift up your notebook to detach it from the Port Replicator.

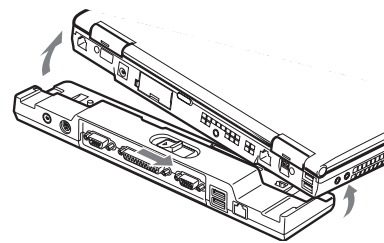

Figure 4-15. Detaching the Port Replicator

Device Ports

Your Fujitsu LifeBook notebook and the optional Port Replicator come equipped with multiple ports to which you can connect external devices including: disk drives, keyboards, modems, printers, etc.

MODEM (RJ-11) TELEPHONE JACK

The modem (RJ-11) telephone jack is used for an internal modem. To connect the telephone cable follow these easy steps:

1. Align the connector with the port opening.
2. Push the connector into the port until it is seated.
3. Plug the other end of the telephone cable into a telephone outlet. (Figure 4-16)

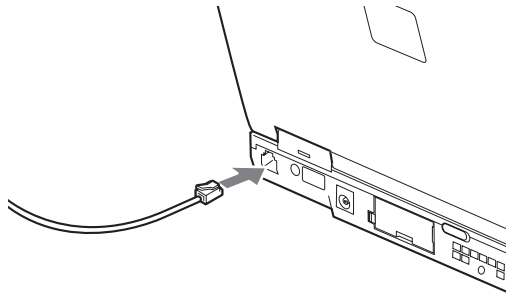

Figure 4-16. Connecting a Modem

The modem sound is deactivated by default, to activate modem sound follow these easy steps:

1. Right click on the Speaker icon in your system tray.
2. Select **Open Volume**.
3. Select **Option/Properties**.
4. Under "Show the following volume controls", click on **Phone** and click **OK**.
5. Uncheck the Mute box under Phone Balance.

WARNING

The internal modem is not intended for use with Digital PBX systems. Do not connect the internal modem to a Digital PBX as it may cause serious damage to the internal modem or your entire LifeBook notebook. Consult your PBX manufacturer's documentation for details. Some hotels have Digital PBX systems. Be sure to find out **BEFORE** you connect your modem.

POINTS

- The internal modem is designed to the ITU-T V.90 standard. Its maximum speed of 53000bps is the highest allowed by FCC, and its actual connection rate depends on the line conditions. The maximum speed is 33600bps at upload.
- The internal modem on all Fujitsu LifeBook notebooks from Fujitsu are certified for use in the United States and Canada. The modem may be certified in other countries.

INTERNAL LAN (RJ-45) JACK

The internal LAN (RJ-45) jack is used for an internal Fast Ethernet (10/100 Base-T/Tx) connection. You may need to configure your notebook to work with your particular network. (Please refer to your network administrator for information on your network configuration.) To connect the LAN cable follow these easy steps:

1. Align the connector with the port opening.
2. Push the connector into the port until it is seated. (Figure 4-17)
3. Plug the other end of the cable into a LAN outlet.

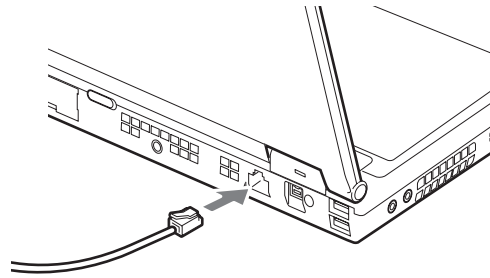

Figure 4-17. Connecting the LAN

PARALLEL PORT

The parallel port, or LPT port, located on the optional Port Replicator allows you to connect parallel devices, such as a printer to your notebook. In order to connect a parallel interface device follow these easy steps:

1. Align the connector with the port opening.
2. Push the connector into the port until it is seated. (Figure 4-18)
3. Tighten the two hold-down screws, located on each end of the connector.

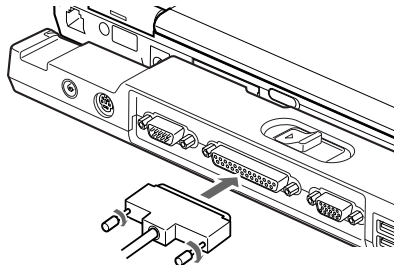

Figure 4-18. Connecting a Parallel Device to Port Replicator

SERIAL PORT

The serial port, or COMM port, located on the optional Port Replicator allows you to connect serial devices, such as printers or scanners. In order to connect a serial interface device follow these easy steps:

1. Align the connector with the port opening.
2. Push the connector into the port until it is seated.
3. Tighten the two hold-down screws, located on each end of the connector.

PS/2 PORT

The PS/2 port located on the optional Port Replicator allow you to connect an external keyboard, numeric keypad, or mouse. In order to connect a PS/2 interface device follow these easy steps:

1. Align the connector with the port opening. (Figure 4-19)
2. Push the connector into the port until it is seated.

POINT

A mouse, keyboard, or keypad may be installed and automatically recognized by your notebook without restarting or changing setups.

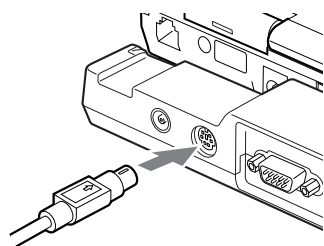

Figure 4-19. Connecting a PS/2 Device

DOCKING PORT

The docking port is used for the connection of your notebook to an optional port replicator or docking station. In order to connect your notebook to one of these devices follow the instructions that came with your docking port. (See figure 2-8 on page 10 for location)

UNIVERSAL SERIAL BUS PORTS

The Universal Serial Bus 2.0 ports (USB) allow you to connect USB devices such as external game pads, pointing devices, keyboards and/or speakers.

In order to connect a USB device follow these steps:

1. Align the connector with the port opening. (Figure 4-20)
2. Push the connector into the port until it is seated.

POINT

Due to the ongoing changes in USB technology and standards, not all USB devices and/or drivers are guaranteed to work.

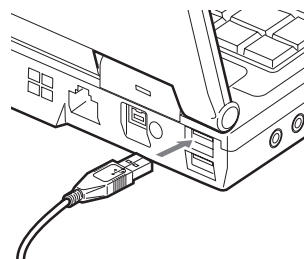

Figure 4-20. Connecting a USB Device

INFRARED PORT

The Infrared IrDA (4Mbps) port allows for wireless data transfer between your notebook and other IrDA-compatible devices, such as another computer or a printer, without the use of a cable. (See figure 2-7 on page 9 for location)

It is important to keep in mind that while carrying out this form of communication, both devices must be placed so their infrared ports are directly facing each other without obstruction. The devices must also be separated by at least 6" but no more than 36" for maximum performance.

The following conditions may interfere with infrared communications:

- A television, radio remote control unit, or a wireless headphone is being used nearby.
- Direct sunlight, fluorescent light, or incandescent light shines directly on the port.

POINT

- Do not move either device while communication is active as it may interrupt data transmission.
- Be careful not to scratch the infrared port lens. Dirt, scratches, or other surface marks can degrade operation.

User Installable Features

STEREO LINE-IN JACK

The stereo line-in jack allows you to connect an external audio source to your notebook, such as an audio cassette player. Your audio device must be equipped with a 1/8" (3.5 mm) stereo mini-plug in order to fit into the stereo line-in jack of your notebook. In order to connect an external audio source follow these easy steps: (See figure 2-7 on page 9 for location)

1. Align the connector with the port opening.
2. Push the connector into the port until it is seated.

POINT

The stereo line-in jack will not support an external microphone.

CAUTION

Turn down the audio volume when connecting electronic devices to the line-in jack. The internal speakers might break if unexpected large sounds are inputted.

IEEE 1394 PORT

The 4-pin 1394 port allows you to connect digital devices that are compliant with IEEE 1394 standard. The IEEE 1394 standard is easy to use, connect, and disconnect. This port can allow up to 400 Mbps transfer rate. A third-party application is required to operate your digital device with the 1394 port.

POINT

The 1394 port used in this system uses a four-pin configuration. If you intend to interface with devices which use a six-pin configuration, you will need to purchase an adapter.

In order to connect a 1394 device, follow these steps:

1. Align the connector with the port opening.
2. Push the connector into the port until it is seated. (Figure 4-21)

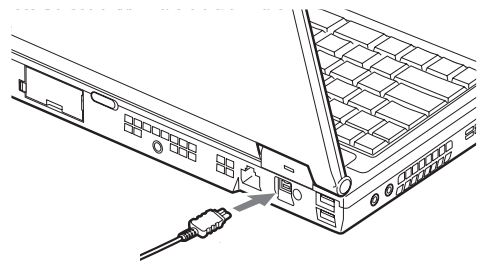

Figure 4-21. Connecting an IEEE 1394 Device

HEADPHONE JACK

The headphone jack allows you to connect headphones or powered external speakers to your notebook. Your headphones or speakers must be equipped with a 1/8" (3.5 mm) stereo mini-plug. In order to connect headphones or speakers follow these easy steps: (See figure 2-6 on page 8 for location)

1. Align the connector with the port opening.
2. Push the connector into the port until it is seated.

POINT

If you plug headphones into the headphone jack, the built-in stereo speakers will be disabled.

MICROPHONE JACK

The microphone jack allows you to connect an external mono microphone. Your microphone must be equipped with a 1/8" (3.5 mm) mono mini-plug in order to fit into the microphone jack of your notebook. In order to connect a microphone follow these easy steps: (See figure on page 7 for location)

1. Align the connector with the port opening.
2. Push the connector into the port until it is seated.

EXTERNAL MONITOR PORT

The external monitor port allows you to connect an external monitor. In order to connect an external monitor follow these easy steps: (See figure 2-7 on page 9 for location)

1. Align the connector with the port opening.
2. Push the connector into the port until it is seated.
3. Tighten the two hold-down screws, located on each end of the connector.

POINT

Pressing the [Fn] + [F10] keys allows you to change your selection of where to send your display video. Each time you press the key combination, you will step to the next choice, starting with the built-in display panel only, moving to the external monitor only, finally moving to both the built-in display panel and an external monitor.

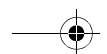
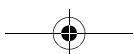
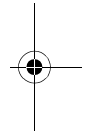
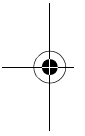
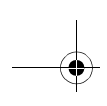

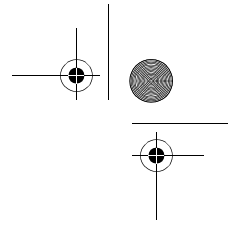
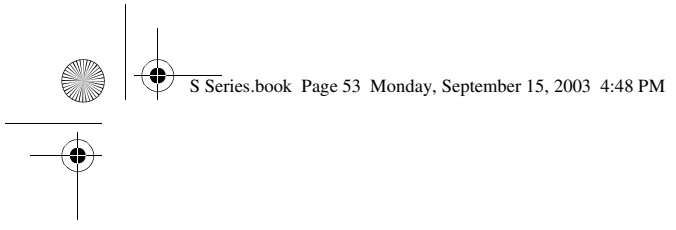

5 Troubleshooting

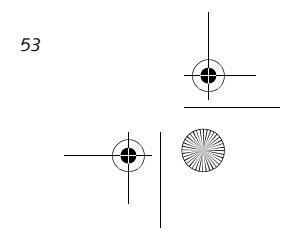
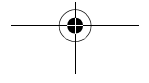
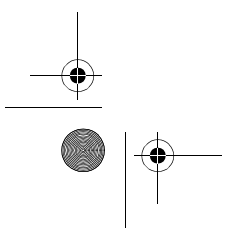
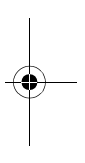
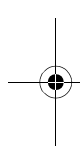

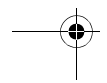
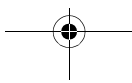
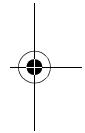
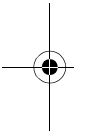
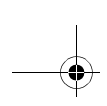

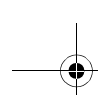

Troubleshooting

Your Fujitsu LifeBook notebook is sturdy and subject to few problems in the field. However, you may encounter simple setup or operating problems that you can solve on the spot, or problems with peripheral devices, that you can solve by replacing the device. The information in this section helps you isolate and resolve some of these straightforward problems and identify failures that require service.

IDENTIFYING THE PROBLEM

If you encounter a problem, go through the following procedure before pursuing complex troubleshooting:

1. Turn off your LifeBook notebook.
2. Make sure the AC adapter is plugged into your notebook and to an active AC power source.
3. Make sure that any card installed in the PC Card slot is seated properly. You can also remove the card from the slot, thus eliminating it as a possible cause of failure.
4. Make sure that any devices connected to the external connectors are plugged in properly. You can also disconnect such devices, thus eliminating them as possible causes of failure.
5. Turn on your notebook. Make sure it has been off at least 10 seconds before you turn it back on.
6. Go through the boot sequence.
7. If the problem has not been resolved, refer to the Troubleshooting Table, that follows, for more detailed troubleshooting information.



POINT

If you keep notes about what you have tried, your support representative may be able to help you more quickly by giving additional suggestions over the phone.

8. If you have tried the solutions suggested in the Troubleshooting Table without success, contact your support representative:

Toll free: 1-800-8Fujitsu (1-800-838-5487)

Fax: 1-901-259-5700

E-mail: 8fujitsu@fujitsupc.com

Web site: <http://www.fujitsupc.com>.

Before you place the call, you should have the following information ready so that the customer support representative can provide you with the fastest possible solution:

- Product name
- Product configuration number
- Product serial number
- Purchase date
- Conditions under which the problem occurred
- Any error messages that have occurred
- Hardware configuration
- Type of device connected, if any

See the Configuration Label on the bottom of your notebook for configuration and serial numbers. (See figure 2-8 on page 10 for location)

SPECIFIC PROBLEMS

Using the Troubleshooting Table

When you have problems with your LifeBook notebook, try to find the symptoms under the Problem column of the troubleshooting table for the feature giving you difficulty. You will find a description of common causes for that symptom under the column Possible Cause and what, if anything, you can do to correct the condition under Possible Solutions. All possible causes or solutions may not apply to your notebook.

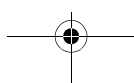
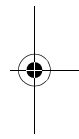
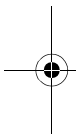

TROUBLESHOOTING TABLE

Problem	Page	Problem	Page
Audio Problems	page 56	Modem Problems.	page 58
DVD/CD-ROM Drive Problems.	page 56	Parallel, Serial and USB Device Problems	page 58
Port Replicator Problems.	page 57	PC Card Problems	page 59
Floppy Disk Drive Problems	page 57	Power Failures	page 59
Hard Drive Problems	page 57	Shutdown and Startup Problems	page 61
Keyboard or Mouse Problems.	page 57	Video Problems	page 61
Memory Problems	page 58	Miscellaneous Problems	page 63

Problem	Possible Cause	Possible Solutions
Audio Problems		
There is no sound coming from the built-in speakers.	The volume is turned too low.	Adjust the volume control on your notebook.
	The software volume control is set too low.	Adjust the sound volume control settings in your software, operating system and applications.
	Headphones are plugged into your notebook.	Plugging in headphones disables the built-in speakers, remove the headphones.
	BIOS audio settings are incorrect.	Set the BIOS setup utility to the default values within the Multimedia Device Configuration menu. (See <i>BIOS Setup Utility on page 29 for more information</i>)
	Software driver is not configured correctly.	Refer to your application and operating system documentation for help.
	The speakers have been muted using the Volume icon in the system tray.	Click on the Volume icon in the tool tray on the bottom right of the screen. (It looks like a speaker). If the Mute box is checked, click on it to uncheck it.
DVD/CD-RW/CD-ROM Drive Problems		
LifeBook notebook fails to recognize DVD/CD-RW/CD-ROM's.	Protective sheet is still in the DVD/CD-RW/CD-ROM drive tray.	Replace DVD/CD-RW/CD-ROM in tray.
	DVD/CD-RW/CD-ROM is not pushed down onto raised center circle of the drive.	Open DVD/CD-RW/CD-ROM tray and re-install DVD/CD-RW/CD-ROM properly.
	DVD/CD-RW/CD-ROM tray is not latched shut.	Push on the front of the DVD/CD-RW/CD-ROM tray until it latches.
	Incorrect DVD Player or no DVD Player software is installed.	Install DVD Player software. (See <i>"Media Player Software" on page 39 for more information.</i>)
	Wrong drive designator was used for DVD/CD-RW/CD-ROM in the application.	Verify the drive designator used by the application is the same as the one used by the operating system. When the operating system is booted from a DVD/CD, drive designations are automatically adjusted.
	Windows DVD/CD-RW/CD-ROM auto insertion function is disabled.	Start the DVD/CD-RW/CD-ROM from the desktop or application software or re-enable the Windows DVD/CD-RW/CD-ROM auto insertion function.

Troubleshooting

Problem	Possible Cause	Possible Solutions
LifeBook notebook fails to recognize DVD/CD-RW/CD-ROM's. (continued)	DVD/CD-RW/CD-ROM is dirty or defective.	Wipe DVD/CD-RW/CD-ROM with a non-abrasive CD cleaning cloth and reinsert. If it still will not work try another DVD/CD-RW/CD-ROM in the drive.
The DVD/CD-RW/CD-ROM Access indicator on the Status Indicator Panel blinks at regular intervals when no DVD/CD-RW/CD-ROM is in the tray or the DVD/CD-RW/CD-ROM drive is not installed.	The Windows DVD/CD-RW/CD-ROM auto insertion function is active and is checking to see if a DVD/CD-RW/CD-ROM is ready to run.	This is normal. However, you may disable this feature.
Port Replicator Problems		
Note: Be sure to power down your LifeBook notebook before adding a printer to the Port Replicator parallel port.		
LifeBook notebook does not turn on when installed in the optional Port Replicator	Port Replicator AC adapter is not plugged in.	Provide power to the Port Replicator.
	Notebook is not properly seated in the Port Replicator.	Remove and re-dock your LifeBook notebook.
Floppy Disk Drive Problems		
You cannot access your floppy disk.	You tried to write to a write protected floppy disk.	Eject the floppy disk and set it to write enable. <i>(See Preparing a Disk for Use on page 42 for more information)</i>
	Floppy disk is not loaded correctly.	Eject floppy disk, check orientation and re-insert. <i>(See Ejecting a Disk on page 42 for more information)</i>
	The floppy disk drive may not be properly installed.	Remove and re-install your floppy disk drive.
	Security is set to protect access to floppy disk data.	Verify your password and security settings.
Hard Drive Problems		
You cannot access your hard drive.	The setup utility is incorrectly set for your internal (Primary Master) or optional second hard drive (Primary Slave).	Revise BIOS settings to set both Primary Master and Primary Slave correctly. <i>(See BIOS Setup Utility on page 29 for more information)</i>
	The wrong drive designator was used by an application when a bootable CD-ROM was used to start the notebook.	Verify drive designator used by application is in use by the operating system. When the operating system is booted from a CD, drive designations are automatically adjusted.
	Security is set so your operating system cannot be started without a password.	Verify your password and security settings.
Keyboard or Mouse Problems		
The built-in keyboard does not seem to work.	The notebook has gone into Suspend mode.	Push the Power/Suspend/Resume button.
	Your application has locked out your keyboard.	Try to use your integrated pointing device to restart your system.

LifeBook S6000 Notebook

Problem	Possible Cause	Possible Solutions
You have installed an external keyboard or mouse, and it does not seem to work.	Your external device is not properly installed.	Re-install your device. (See <i>Device Ports</i> on page 49 for more information)
	Your operating system software is not setup with the correct software driver for that device.	Check your device and operating system documentation and activate the proper driver.
	Your mouse or keyboard is connected to the wrong PS/2 port on the optional Port Replicator.	Plug the mouse into the PS/2 Mouse port and the external keyboard or numeric key pad into the PS/2 Keyboard port. (See <i>PS/2 Port</i> on page 50 for more information)
You have connected an external keyboard or a mouse and it seems to be locking up the system.	Your operating system software is not setup with the correct software driver for that device.	Check your device and operating system documentation and activate the proper driver.
	Your system has crashed.	Try to restart your notebook. I
Memory Problems		
Your Power On screen, or Main menu of the BIOS setup utility information, does not show the correct amount of installed memory.	Your memory upgrade module is not properly installed.	Remove and re-install your memory upgrade module. (See <i>Memory Upgrade Module</i> on page 45 for more information)
	You have a memory failure.	Check for Power On Self Test (POST) messages. (See <i>Power On Self Test Messages</i> on page 64 for more information)
Modem Problems		
Messages about modem operation.	Messages about modem operation are generated by whichever modem application is in use.	See your application software documentation for additional information.
Parallel, Serial, and USB Device Problems		
You have installed a parallel port device, a serial port device or a USB device. Your LifeBook notebook does not recognize the device, or the device does not seem to work properly.	The device is not properly installed.	Remove and re-install the device. (See <i>Device Ports</i> on page 49 for more information)
	The device may have been installed while an application was running, so your notebook is not aware of its installation.	Close the application and restart your notebook.
	Your device may not have the correct software driver active.	See your software documentation and activate the correct driver.
	You may have the wrong I/O address selected for your device.	See your device documentation and software documentation to determine the required I/O address. Change the settings in the BIOS setup utility. (See <i>BIOS Setup Utility</i> on page 29 for more information)
	Your device and another device are assigned the same I/O address.	Check all I/O addresses located within the BIOS setup utility and any other installed hardware or software to make sure there are no duplications.
	Parallel port is set to output only.	Check parallel port setting in the BIOS and set to bi-directional or ECP.

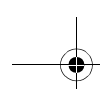
**Troubleshooting**

Problem	Possible Cause	Possible Solutions
PC Card Problems		
A card inserted in the PC Card slot does not work or is locking up the system.	The card is not properly installed.	Remove and re-install the card. (See <i>PC Cards on page 43 for more information</i>)
	The card may have been installed while an application was running, so your notebook is not aware of its installation.	Close the application and restart your notebook.
	Your software may not have the correct software driver active.	See your software documentation and activate the correct driver.
	You may have the wrong I/O address selected for your PC Card device.	See your PC Card documentation to determine the required I/O address. Change the settings in the BIOS. (See <i>BIOS Setup Utility on page 29 for more information</i>)
	Your PC Card device and another device are assigned the same I/O address.	Check all I/O addresses located within the BIOS setup utility and any other installed hardware or software to make sure there are no duplications.
Power Failures		
You turn on your LifeBook notebook and nothing seems to happen.	The installed primary battery is completely discharged, there is no optional second battery installed or there is no Power adapter (AC or Auto/Airline) installed.	Check the Status Indicator Panel to determine the presence and condition of the batteries. (See <i>Status Indicator Panel on page 11 for more information</i>) Install a charged battery or a Power adapter.
	The primary battery is installed but is faulty.	Use the Status Indicator panel to verify the presence and condition of the batteries. (See <i>Status Indicator Panel on page 11 for more information</i>) If a battery is indicating a short, remove that battery and operate from another power source or replace that battery.
	The battery or batteries are low.	Check the Status Indicator Panel to determine the presence and condition of the batteries. (See <i>Status Indicator Panel on page 11 for more information</i>) Use a Power adapter to operate until a battery is charged or install a charged battery.
	The power adapter (AC or auto/airline) is not plugged in properly.	Verify that your adapter is connected correctly. (See <i>Power Sources on page 27 for more information</i>)
	The Power adapter (AC or auto/airline) has no power from the AC outlet, airplane seat jack, or the car's cigarette lighter.	Move the AC cord to a different outlet, check for a line switch or tripped circuit breaker for the AC outlet. If you are using an auto/airline adapter in a car make sure the ignition switch is in the On or Accessories position.
	The Power adapter (AC or auto/airline) is faulty.	Try a different Power adapter or install a charged optional second battery.

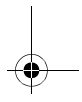
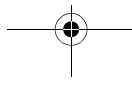
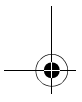
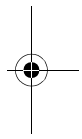
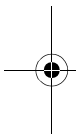

LifeBook S6000 Notebook

Problem	Possible Cause	Possible Solutions
Your LifeBook notebook turns off all by itself.	The power management parameters are set for auto timeouts which are too short for your operating needs.	Press any button on the keyboard, or move the mouse to restore operation. If that fails, push the Power/Suspend/Resume button. Check your power management settings, or close your applications and go to the Power Savings menu of the setup utility to adjust the timeout values to better suit your needs.
	You are operating on battery power only and have ignored a low battery alarm until the batteries are all at the dead battery state and your machine has gone into Dead Battery Suspend mode.	Install a power adapter and then push the Power/Suspend/Resume button. (See <i>Power Sources on page 27 for more information</i>)
	You have a battery failure.	Verify the condition of the batteries using the Status Indicator panel, and replace or remove any batteries that are shorted. (See <i>Status Indicator Panel on page 11 for more information</i>)
	Your power adapter has failed or lost its power source.	Make sure the adapter is plugged in and the outlet has power.
Your LifeBook notebook will not work on battery alone.	The installed batteries are dead.	Replace the battery with a charged one or install a Power adapter.
	No batteries are installed.	Install a charged battery.
	The batteries are improperly installed.	Verify that the batteries are properly connected by re-installing them.
	Your installed batteries are faulty.	Verify the condition of the batteries using the Status Indicator panel and replace or remove any batteries that are shorted. (See <i>Status Indicator Panel on page 11 for more information</i>)
The batteries seem to discharge too quickly.	You are running an application that uses a great deal of power due to frequent hard drive access or DVD/CD-ROM access, use of a modem card or a LAN PC card.	Use both the primary battery and an optional second battery and/or use a power adapter for this application when at all possible.
	The power savings features may be disabled.	Check the power management and/or setup utility settings in the Power Savings menu and adjust according to your operating needs.
	The brightness is turned all the way up.	Turn down the brightness adjustment. The higher the brightness the more power your display uses.
	The batteries are very old.	Replace the batteries.
	The batteries have been exposed to high temperatures.	Replace the batteries.
	The batteries are too hot or too cold.	Restore the notebook to normal operating temperature. The Charging icon on the Status Indicator panel will flash when the battery is outside its operating range.

Troubleshooting

Problem	Possible Cause	Possible Solutions
Shutdown and Startup Problems		
The Suspend/Resume button does not work.	The Suspend/Resume button is disabled from the Advanced submenu of the Power menu of the setup utility.	Enable the button from the setup utility.
	You did not hold the button in long enough.	Hold the button longer. This may need to be a few seconds if your application is preventing the CPU from checking for button pushes.
	There may be a conflict with the application software.	Close all applications and try the button again.
The system powers up, and displays power on information, but fails to load the operating system.	The boot sequence settings of the setup utility are not compatible with your configuration.	Set the operating source by pressing the [ESC] key while the Fujitsu logo is on screen or use the [F2] key and enter the setup utility and adjust the source settings from the Boot menu. <i>(See BIOS Setup Utility on page 29 for more information)</i>
	You have a secured system requiring a password to load your operating system.	Make sure you have the right password. Enter the setup utility and verify the Security settings and modify them as accordingly. <i>(See BIOS Setup Utility on page 29 for more information)</i>
	Internal hard drive was not detected.	Use the BIOS setup utility or Primary Master submenu, located within the Main menu, to try to auto detect the internal hard drive.
An error message is displayed on the screen during the notebook (boot) sequence.	Power On Self Test (POST) has detected a problem.	See the Power On Self Test (POST) messages to determine the meaning and severity of the problem. Not all messages are errors; some are simply status indicators. <i>(See Power On Self Test Messages on page 64 for more information)</i>
Your notebook appears to change setup parameters when you start it.	BIOS setup changes were not saved when you made them and exited the BIOS setup utility returning it to previous settings.	Make sure you select Save Changes And Exit when exiting the BIOS setup utility.
	The BIOS CMOS hold-up battery has failed.	Contact your support representative for repairs. This is not a user serviceable part but has a normal life of 3 to 5 years.
Your system display won't turn on when the system is turned on or when the system has resumed.	The system may be password-protected.	Check the status indicator panel to verify that the Security icon is blinking. If it is blinking, enter your password.
Video Problems		
The built-in display is blank when you turn on your LifeBook notebook.	Something is pushing on the Closed Cover switch.	Clear the Closed Cover switch. <i>(See figure 2-4 on page 6 for location)</i>

LifeBook S6000 Notebook

Problem	Possible Cause	Possible Solutions
The built-in display is blank when you turn on your LifeBook notebook. (continued)	The notebook is set for an external monitor only.	Pressing [F10] while holding down the [Fn] key allows you to change your selection of where to send your display video. Each time you press the combination of keys you will step to the next choice. The choices, in order are: built-in display only, external monitor only, both built-in display and external monitor.
	The angle of the display and the brightness settings are not adequate for your lighting conditions.	Move the display and the brightness control until you have adequate visibility.
	The power management time-outs may be set for very short intervals and you failed to notice the display come on and go off again.	Press any button the keyboard, or move the mouse to restore operation. If that fails, push the Power/Suspend/Resume button. (The display may be shut off by Standby mode, Auto Suspend or Video Timeout)
The LifeBook notebook turned on with a series of beeps and your built-in display is blank.	Power On Self Test (POST) has detected a failure which does not allow the display to operate.	Contact your support representative.
The display goes blank by itself after you have been using it.	The notebook has gone into Video timeout, Standby mode, Suspend mode or Save-to-Disk mode because you have not used it for a period of time.	Press any button on the keyboard, or move the mouse to restore operation. If that fails, push the Power/Suspend/Resume button. Check your power management settings, or close your applications and go to the Power Savings menu of the setup utility to adjust the timeout values to better suit your operation needs. (See <i>BIOS Setup Utility on page 29 for more information</i>)
	The power management time-outs may be set for very short intervals and you failed to notice the display come on and go off again.	Press any button on the keyboard, or move the mouse to restore operation. If that fails, push the Power/Suspend/Resume button. (The display may be shut off by Standby Mode, Auto Suspend or Video Timeout)
	Something is pushing on the Closed Cover switch.	Check the Closed Cover switch. (See <i>figure 2-4 on page 6 for location</i>)
Your system display won't turn on when the system is turned on or when the system has resumed.	The system may be password-protected.	Check the status indicator panel to verify that the Security icon is blinking. If it is blinking, enter your password.
The Built-in Display does not close.	A foreign object, such as a paper clip, is stuck between the display and the keyboard.	Remove all foreign objects from the keyboard.
The Built-in Display has bright or dark spots.	If the spots are very tiny and few in number, this is normal for a large LCD display.	This is normal; do nothing.
	If the spots are numerous or large enough to interfere with your operation needs.	Display is faulty; contact your support representative.

**Troubleshooting**

Problem	Possible Cause	Possible Solutions
The application display uses only a portion of your screen and is surrounded by a dark frame.	You are running an application that does not support 800 x 600/1024 x 768 pixel resolution display and display compression is enabled.	Display compression gives a clearer but smaller display for applications that do not support 800 x 600/1024 x 768 pixel resolution. You can fill the screen but have less resolution by changing your display compression setting. (See the Video Features submenu, located within the Advanced menu of the BIOS. (See <i>BIOS Setup Utility</i> on page 29 for more information))
The Display is dark when on battery power.	The Power Management utility default is set on low brightness to conserve power.	Press [Fn] + [F7] to increase brightness or double-click on the battery gauge and adjust Power Control under battery settings.
You have connected an external monitor and it does not display any information.	Your BIOS setup is not set to enable your external monitor.	Try toggling the video destination by pressing [Fn] and [F10] together, or check your BIOS setup and enable your external monitor. (See the Video Features submenu, located within the Advanced Menu of the BIOS. (See <i>BIOS Setup Utility</i> on page 29 for more information))
	Your external monitor is not properly installed.	Reinstall your device. (See <i>External Monitor Port</i> on page 51 for more information)
	Your operating system software is not setup with the correct software driver for that device.	Check your device and operating system documentation and activate the proper driver.
You have connected an external monitor and it does not come on.	Your external monitor is not compatible with your LifeBook notebook.	See your monitor documentation and the External Monitor Support portions of the Specifications section. (See <i>Specifications</i> on page 77 for more information)
Miscellaneous Problems		
An error message is displayed on the screen during the operation of an application.	Application software often has its own set of error message displays.	See your application manual and help displays screens for more information. Not all messages are errors some may simply be status.

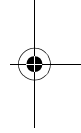
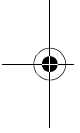

POWER ON SELF TEST MESSAGES

The following is an alphabetic list of error-and-status messages that Phoenix BIOS and/or your operating system can generate and an explanation of each message. Error messages are marked with an *. If an error message is displayed that is not in this list, write it down and check your operating system documentation both on screen and in the manual. If you can find no reference to the message and its meaning is not clear, contact your support representative for assistance.

nxxx Cache SRAM Passed

Where nxxx is the amount of system cache in kilobytes successfully tested by the Power On Self Test. (This can only appear if you have an SRAM PC Card installed.)

***Diskette drive A error or Diskette drive B error**

Drive A: or B: is present but fails the BIOS Power On Self Test diskette tests. Check to see that the drive is defined with the proper diskette type in the Setup Utility, (*See BIOS Setup Utility on page 29 for more information*) and that the diskette drive is installed correctly. If the disk drive is properly defined and installed, avoid using it and contact your support representative.

***Extended RAM Failed at offset: nxxx**

Extended memory not working or not configured properly. If you have an installed memory upgrade module, verify that the module is properly installed. If it is properly installed, you may want to check your Windows Setup to be sure it is not using unavailable memory until you can contact your support representative.

nxxx Extended RAM Passed

Where nxxx is the amount of memory in kilobytes successfully tested.

***Failing Bits: nxxx The hex number nxxx**

This is a map of the bits at the memory address (in System, Extended, or Shadow memory) which failed the memory test. Each 1 (one) in the map indicates a failed bit. This is a serious fault that may cause you to lose data if you continue. Contact your support representative.

***Fixed Disk x Failure or Fixed Disk Controller Failure (where x = 1-4)**

The fixed disk is not working or not configured properly. This may mean that the hard drive type identified in your setup utility does not agree with the type detected by the Power On Self Test. Run the setup utility to check for the hard drive type settings and correct them if necessary. If the settings are OK and the message appears when you restart the system, there may be a serious fault which might cause you to lose data if you continue. Contact your support representative.

***Incorrect Drive A type – run SETUP**

Type of floppy drive A: not correctly identified in Setup. This means that the floppy disk drive type identified in your setup utility does not agree with the type detected by the Power On Self Test. Run the setup utility to correct the inconsistency.

***Incorrect Drive B type – run SETUP**

Type of floppy drive B: not correctly identified in Setup. This means that the floppy disk drive type identified in your setup utility does not agree with the type detected by the Power On Self Test. Run the setup utility to correct the inconsistency.

***Invalid NVRAM media type**

Problem with NVRAM access. In the unlikely case that you see this message you may have some display problems. You can continue operating but should contact your support representative for more information.

***Keyboard controller error**

The keyboard controller test failed. You may have to replace your keyboard or keyboard controller but may be able to use an external keyboard until then. Contact your support representative.

***Keyboard error**

Keyboard not working. You may have to replace your keyboard or keyboard controller but may be able to use an external keyboard until then. Contact your support representative.

***Keyboard error nn**

BIOS discovered a stuck key and displays the scan code for the stuck key. You may have to replace your keyboard but may be able to use an external keyboard until then. Contact your support representative.

***Monitor type does not match CMOS – Run SETUP**

Monitor type not correctly identified in Setup. This error probably means your BIOS is corrupted, run the setup utility and set all settings to the default conditions. If you still get this error, contact your support representative.

***Operating system not found**

Operating system cannot be located on either drive A: or drive C: Enter the setup utility and see if both the fixed disk, and drive A: are properly identified and that the boot sequence is set correctly. Unless you have changed your installation greatly, the operating system should be on drive C:. If the setup utility is correctly set, your hard drive may be corrupted.

***Parity Check 1 nxxx**

Parity error found in the system bus. BIOS attempts to locate the address and display it on the screen. If it cannot locate the address, it displays ????. This is a potentially data destroying failure. Contact your support representative.

Troubleshooting

***Parity Check 2 nnnn**

Parity error found in the I/O bus. BIOS attempts to locate the address and display it on the screen. If it cannot locate the address, it displays ????. This is a potentially data-destroying failure. Contact your support representative.

***Press <F1> to resume, <F2> to SETUP**

Displayed after any recoverable error message. Press the [F1] key to continue the boot process or the [F2] key to enter Setup and change any settings.

***Previous boot incomplete – Default configuration used**

Previous Power On Self Test did not complete successfully. The Power On Self Test will load default values and offer to run Setup. If the previous failure was caused by incorrect values and they are not corrected, the next boot will likely fail also. If using the default settings does not allow you to complete a successful boot sequence, you should turn off the power and contact your support representative.

***Real time clock error**

Real-time clock fails BIOS test. May require board repair. Contact your support representative.

***Shadow RAM Failed at offset: nnnn**

Shadow RAM failed at offset nnnn of the 64k block at which the error was detected. You are risking data corruption if you continue. Contact your support representative.

nnnn Shadow RAM Passed

Where nnnn is the amount of shadow RAM in kilobytes successfully tested.

***System battery is dead – Replace and run SETUP**

The BIOS CMOS RAM memory hold up battery is dead. This is part of your BIOS and is a board mounted battery which requires a support representative to change. You can continue operating but you will have to use setup utility default values or reconfigure your setup utility every time you turn off your notebook. This battery has an expected life of 2 to 3 years.

System BIOS shadowed

System BIOS copied to shadow RAM.

***System CMOS checksum bad – run SETUP**

BIOS CMOS RAM has been corrupted or modified incorrectly, perhaps by an application program that changes data stored in BIOS memory. Run Setup and reconfigure the system.

***System RAM Failed at offset: nnnn**

System memory failed at offset nnnn of in the 64k block at which the error was detected. This means that there is a fault in your built-in memory. If you continue to operate, you risk corrupting your data. Contact your support representative for repairs.

nnnn System RAM Passed

Where nnnn is the amount of system memory in kilobytes successfully tested.

***System timer error**

The timer test failed. The main clock that operates the computer is faulty. Requires repair of system board. Contact your support representative for repairs.

UMB upper limit segment address: nnnn

Displays the address of the upper limit of Upper Memory Blocks, indicating released segments of the BIOS memory which may be reclaimed by a virtual memory manager.

Video BIOS shadowed

Video BIOS successfully copied to shadow RAM.

EMERGENCY MEDIA PLAYER DRIVE TRAY RELEASE

If for some reason the eject button fails, you can open the DVD/CD-ROM tray with a paper clip or similar tool inserted into the eject hole in the far right side of the front of the tray. Straighten one side of a paper clip and push it gently into the hole. The tray will pop out a short distance.

MODEM RESULT CODES

The operating system and application software that is factory installed detects the modem characteristics and provides the necessary command strings to operate the modem. The internal modem operation is controlled by generic AT commands from the operating system and application software. The standard long form result codes may, in some cases, be displayed on your screen to keep you informed of the actions of your modem. The operating system and application software may suppress display of the result codes.

Examples of result codes are:

- OK
- NO CARRIER
- NO DIALTONE
- CONNECT 53000 (Connection complete at 53,000 bps.)
- ERROR
- FAX
- RING (This means an incoming call.)
- BUSY
- NO ANSWER

When using the internal modem with applications that are not factory installed refer to the application documentation.

RESTORING YOUR PRE-INSTALLED SOFTWARE

The Drivers and Applications Restore (DAR) CD contains:

- Sets of device drivers and Fujitsu utilities (in specific directories) that are unique to your LifeBook notebook configuration for use as documented below.
- A link to the Drive Image Special Edition (DISE) utility on your hard disk drive.
- Read-me files that provide additional use information for items on this CD-ROM.

CAUTION

If the DAR CD is in the drive when you boot up the system, a message will appear informing you that continuing to boot from the CD will overwrite all information on the hard drive, including saved files, and restore the hard drive to its factory configuration. If you wish to install drivers or applications **only** from the CD, remove the disk from the drive, reboot the system, and insert the CD after Windows has started.

POINT

If you have access to the internet, visit the Fujitsu Support web site at www.fujitsupc.com to check for the most current information, drivers and hints on how to perform recovery and system updates.

DRIVE IMAGE SPECIAL EDITION (DISE)

PowerQuest Drive Image Special Edition (DISE) provides a way to restore your computer if you experience a hard disk crash or other system failure. Fujitsu has used DISE to create an image of everything installed on the computer at the time you purchased it. The image is saved on a separate partition on the hard disk. You can use DISE to restore the factory image and return your computer to the state in which it was shipped from Fujitsu.

Although it is not necessary, you can use DISE to store additional image files that you create. For example, if you install several applications and save data files on your hard disk, you can create a new image file that includes them and then save that image file on the hard disk. Then, in the event of a hard disk failure, you can restore the image that includes the applications and data files you use.

POINT

Using the DISE feature will reduce the amount of usable disk space on your hard disk drive.

Creating a Backup Image

You can create a backup image of your C:\ drive at any time. The C:\ partition must be a FAT, FAT32, or NTFS partition, and it must be directly before the backup partition on your hard disk.

There are two ways to implement the DISE utility: When booting up the system, or from the desktop.

Creating a backup image when booting up

Before creating a backup image at boot-up, you must first change the boot-up priority in the BIOS so that the system will go to the CD drive first, rather than trying to boot-up from the hard drive or an external floppy disk drive.

To change the boot-up priority:

1. Start your system and press the [F2] key when the Fujitsu logo appears. You will enter the BIOS Setup Utility.
2. Using the arrow keys, go to the Boot menu.
3. Arrow down to the Boot Device Priority submenu and press [Enter].
4. Arrow down to the CD-ROM drive in the list, and press the space bar (or the + key) to move the CD-ROM drive to the top of the list. (The system attempts to boot from the devices in the order in which they are listed.)
5. Press [F10], then click on [Yes] to exit the BIOS Setup Utility and return to the boot process.

After you have changed the boot priority, you can create a backup image when you are booting up:

1. Install the DAR CD in the drive prior to booting up. When bootup begins, a message will appear informing you that continuing to boot from the CD will overwrite all information on the hard drive, including saved files, and restore the hard drive to its factory configuration.
2. When you are asked if you want to restore the factory image, click [Y]es.

Creating a backup image from the desktop

To create a backup image from the desktop, select Drive Image SE from the Program list. You will initially be prompted to create a backup diskette. It is not necessary to create the backup diskette, since the DAR CD performs the same function.

1. At the Drive Image Special Edition main screen, click **Options> Create New Backup**. DISE displays a warning that it must go to DOS to create the image.
3. Click **Yes**.
DISE creates an image file in the backup partition. If you created a backup image previously, the new image overwrites the old one.



Enlarging the Backup Partition

If there is not enough unused space in the backup partition on your hard disk, DISE will resize the partition. DISE will display the minimum, maximum, and recommended sizes for the backup partition. You choose the size you want.

DISE takes the space from the FAT, FAT32, or NTFS partition that you are backing up. If there is not enough unused space in that partition to take, you will not be able to resize the backup partition and create an image file. You can delete files from the FAT, FAT32, or NTFS partition to create more unused space on the hard disk.

Restoring a Backup Image

You can restore either a factory image or a backup image you created. Be aware that restoring a backup image will replace the contents of the C:\ partition with the image you restore.

1. Disable virus protection software. If virus protection software is enabled, DISE will hang.
2. From the DISE main window, click **Options > Restore Backup** to restore an image you created, or click **Options > Restore Factory Backup** to restore the factory image.

DISE shuts down to DOS and restores the image file.

Re-Installing Individual Drivers and Applications

The Drivers and Application CD can be used to selectively re-install drivers and/or applications that may have been un-installed or corrupted.

To re-install drivers and/or applications:

1. Boot up the system and insert the DAR CD after Windows has started. The LifeBook Easy Installation screen appears.
2. Select the drivers and applications you want to install from the list that is displayed.
3. Click [Start]. Follow the prompts that appear to complete installation of the selected drivers and/or applications.

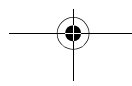
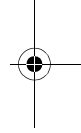
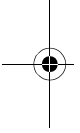

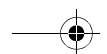
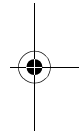
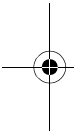
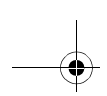

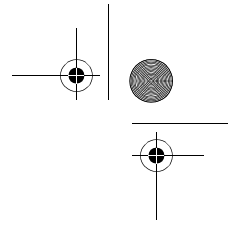
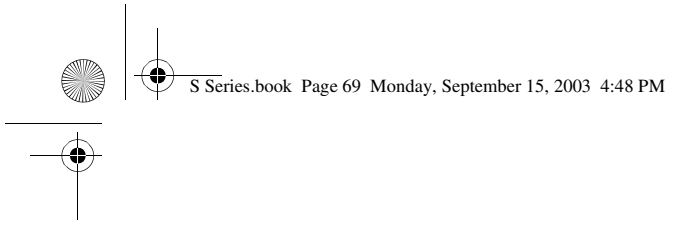

6 Care and Maintenance

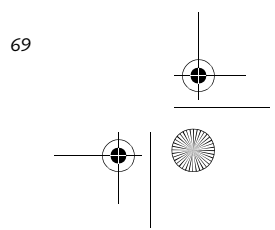
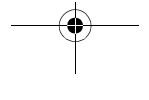
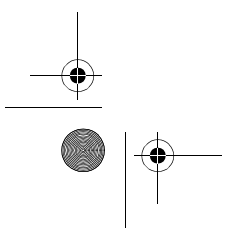
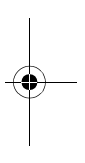
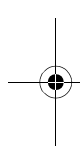

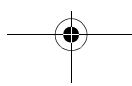
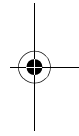
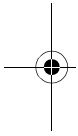
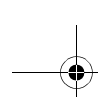

Care and Maintenance

If you use your Fujitsu LifeBook notebook carefully, you will increase its life and reliability. This section provides some tips for looking after the notebook and its devices.

WARNING

Electrical equipment may be hazardous if misused. Operations of this product or similar products, must always be supervised by an adult. Do not allow children access to the interior of any electrical products and do not permit them to handle any cables.

Caring for your LifeBook notebook

- Your LifeBook notebook is a durable but sensitive electronic device. Treat it with respect and care.
- Make a habit of transporting it in a suitable carrying case.
- Do not attempt to service the computer yourself. Always follow installation instructions closely.
- Keep it away from food and beverages.
- If you accidentally spill liquid on your LifeBook notebook:
 1. Turn it off.
 2. Position it so that the liquid can run out.
 3. Let it dry out for 24 hours, or longer if needed.
 4. If your notebook will not boot after it has dried out, call your support representative.
- Do not use your Fujitsu LifeBook notebook in a wet environment (near a bathtub, swimming pool).
- Always use the AC adapter and batteries that are approved for your notebook.
- Avoid exposure to sand, dust and other environmental hazards.
- Do not expose your notebook to direct sunlight for long periods of time as temperatures above 140° F (60° C) may damage your notebook.
- Keep the covers closed on the connectors and slots when they are not in use.
- Do not put heavy or sharp objects on the computer.
- If you are carrying your LifeBook notebook in a briefcase, or any other carrying case, make sure that there are no objects in the case pressing on the lid.
- Never position your notebook such that the media player drive is supporting the weight of the notebook.
- Do not drop your notebook.
- Do not touch the screen with any sharp objects.

Cleaning your LifeBook notebook





- Always disconnect the power plug. (Pull the plug, not the cord.)
- Clean your LifeBook notebook with a damp, lint-free cloth. Do not use abrasives or solvents.
- Use a soft cloth to remove dust from the screen. Never use glass cleaners.

Storing your LifeBook notebook

- If storing your notebook for a month or longer, turn your LifeBook notebook off, fully charge the battery(s), then remove and store all Lithium ion batteries.
- Store your notebook and batteries separately. If you store your LifeBook with a battery installed, the battery will discharge, and battery life will be reduced. In addition, a faulty battery might damage your LifeBook.
- Store your Fujitsu LifeBook in a cool, dry location. Temperatures should remain between 13°F (-25°C) and 140°F (60°C).

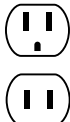
Traveling with your LifeBook notebook

- Do not transport your notebook while it is turned on.
- It is recommended that you carry your notebook with you while travelling, rather than checking it in as baggage.
- Always bring your System Recovery CD that came with your notebook when you travel. If you experience system software problems while traveling, you may need it to correct any problems.
- Never put your notebook through a metal detector. Have your notebook hand-inspected by security personnel. You can however, put your notebook through a properly tuned X-ray machine. To avoid problems, place your notebook close to the entrance of the machine and remove it as soon as possible or have your notebook hand-inspected by security personnel. Security officials may require you to turn your notebook On. Make sure you have a charged battery on hand.
- When traveling with the hard drive removed, wrap the drive in a non-conducting materials (cloth or paper). If you have the drive checked by hand, be ready to install the drive if needed. Never put your hard drive through a metal detector. Have your hard drive hand-inspected by security personnel. You can however, put your hard drive through a properly tuned X-ray machine.
- Take the necessary plug adapters if you're traveling overseas. Check the following diagram to determine which plug adapter you'll need or ask your travel agent.

Outlet Type	Location
	United States, Canada, parts of Latin America, Mexico, Japan, Korea, the Philippines, Taiwan
	Russia and the Commonwealth of Independent States (CIS), most of Europe, parts of Latin America, the Middle East, parts of Africa, Hong Kong, India, most of South Asia
	United Kingdom, Ireland, Malaysia, Singapore, parts of Africa
	China, Australia, New Zealand

BATTERIES

Caring for your Batteries

- Always handle batteries carefully.
- Do not short-circuit the battery terminals (that is, do not touch both terminals with a metal object). Do not carry loose batteries in a pocket or purse where they may mix with coins, keys, or other metal objects. Doing so may cause an explosion or fire.
- Do not drop, puncture, disassemble, mutilate or incinerate the battery.
- Recharge batteries only as described in this manual and only in ventilated areas.
- Do not leave batteries in hot locations for more than a day or two. Intense heat can shorten battery life.
- Do not leave a battery in storage for longer than 6 months without recharging it.

Increasing Battery Life

- Power your LifeBook notebook through the AC or optional auto/airline adapter whenever possible.
- If your notebook is running on battery power all day, connect it to the AC adapter overnight to recharge the battery.
- Keep brightness to the lowest level comfortable.
- Set the power management for maximum battery life.
- Put your notebook in Suspend mode when it is turned on and you are not actually using it.
- Limit your media drive access.

- Disable the Media Player auto insert notification function.
- Always use fully charged batteries.
- Eject PCMCIA™ cards when not in use.

FLOPPY DISKS AND DRIVES

Caring for your Floppy Disks

- Avoid using the floppy disks in damp and dusty locations.
- Never store a floppy disk near a magnet or magnetic field.
- Do not use a pencil or an eraser on a disk or disk label.
- Avoid storing the floppy disks in extremely hot or cold locations, or in locations subject to severe temperature changes. Store at temperatures between 50° F (10°C) and 125°F (52°C).
- Do not touch the exposed part of the disk behind the metal shutter.
- Never use the floppy disk drive with any liquid, metal, or other foreign matter inside the floppy disk drive or disk.
- Never disassemble your floppy disk drive.

MEDIA CARE

Caring for your Media (DVD/CD/CD-R)

- Media discs are precision devices and will function reliably if given reasonable care.
- Always store your media disc in its case when it is not in use.
 - Always handle discs by the edges and avoid touching the surface.
 - Avoid storing any media discs in extreme temperatures.
 - Do not bend media discs or set heavy objects on them.
 - Do not spill liquids on media discs.
 - Do not scratch media discs.
 - Do not get dust on media discs.
 - Never write on the label surface with a ballpoint pen or pencil. Always use a felt pen.
 - If a media disc is subjected to a sudden change in temperature, cold to warm condensation may form on the surface. Wipe the moisture off with a clean, soft, lint free cloth and let it dry at room temperature. DO NOT use a hair dryer or heater to dry media discs.
 - If a disc is dirty, use only a DVD/CD cleaner or wipe it with a clean, soft, lint free cloth starting from the inner edge and wiping to the outer edge.



Care and Maintenance

Caring for your Media Player Drive

Your media player drive is durable but you must treat it with care. Please pay attention to the following points:

- The drive rotates the compact disc at a very high speed. Do not carry it around or subject it to shock or vibration with the power on.
- Avoid using or storing the drive where it will be exposed to extreme temperatures.
- Avoid using or storing the drive where it is damp or dusty.
- Avoid using or storing the drive near magnets or devices that generate strong magnetic fields.
- Avoid using or storing the drive where it will be subjected to shock or vibration.
- Do not disassemble or dismantle the media player drive.
- Use of a commercially available lens cleaner is recommended for regular maintenance of your drive.

PC CARDS

Caring for your PC Cards

PC Cards are durable, but you must treat them with care. The documentation supplied with your PC Card will provide specific information, but you should pay attention to the following points:

- To keep out dust and dirt, store PC Cards in their protective sleeves when they are not installed in your LifeBook notebook.
- Avoid prolonged exposure to direct sunlight or excessive heat.
- Keep the cards dry.
- Do not flex or bend the cards, and do not place heavy objects on top of them.
- Do not force cards into the slot.
- Avoid dropping cards, or subjecting them to excessive vibration.

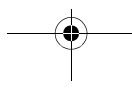
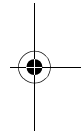
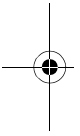

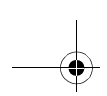

LifeBook S6000 Notebook

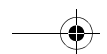
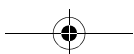
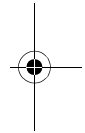
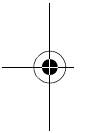

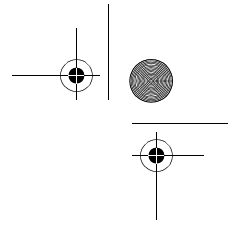
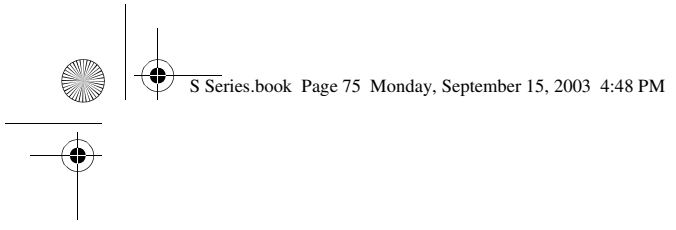

7 Specifications

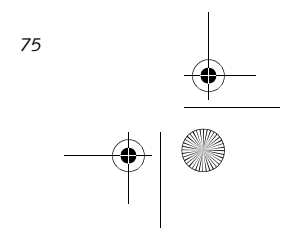
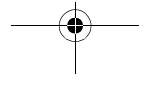
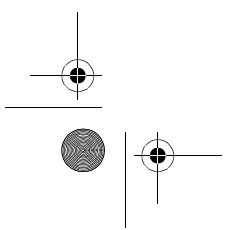
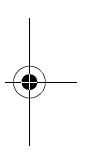
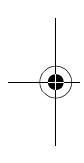

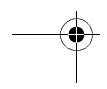
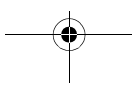
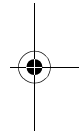
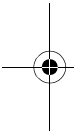
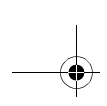

Specifications

Specifications

This section provides the hardware and environmental specifications for your Fujitsu LifeBook notebook. Specifications of particular configurations will vary.

CONFIGURATION LABEL

There is a configuration label located on the bottom of your LifeBook notebook. (See figure 2-8 on page 10 for location) This label contains specific information regarding the options you've chosen for your notebook. Following is an example label and information on how to read your own configuration label.

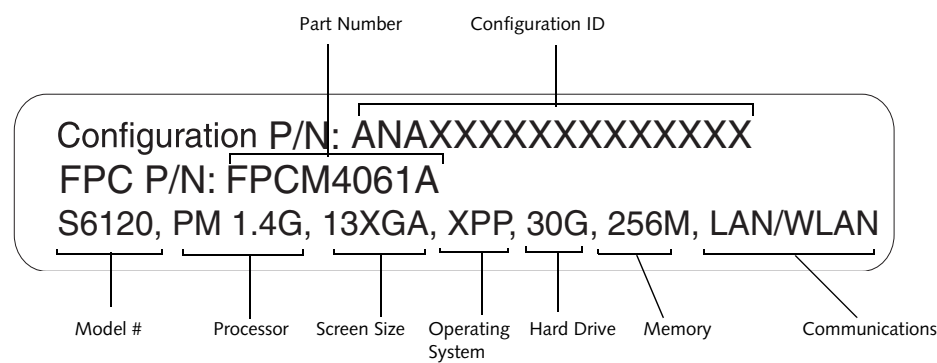

Figure 7-1 Configuration Label

MICROPROCESSOR

Intel Pentium M processor (Refer to the system label to determine the speed of your processor).

CHIPSET

Intel 855 GM

MEMORY

System Memory
 DDR 266 SDRAM memory module.
 256 MB pre-installed in one DIMM slot;
 one open DIMM slot available for upgrade.
 Upgradeable to 2 GB of total memory (1 GB x 2)

Cache Memory

1MB L2 on-die

BIOS Memory

8Mbit Firmware Hub (FWH) Flash ROM
 256 Bytes CMOS RAM with back-up battery

VIDEO

Built-in color flat-panel TFT active matrix LCD display with simultaneous display capability

Video Color and Resolution

- 13.3" TFT XGA
- Internal: 1024 x 768 pixel resolution, 16M colors
- External: 1600 x 1200 pixel resolution, 16M colors
- Simultaneous Video: 1024 x 768, 16M colors. XGA, SVGA and VGA compatible

Video RAM

Intel® 855GM video graphics chip with integrated 32-bit 3D/2D gfx core with Accelerated Graphics Port (AGP) support. Up to 64MB shared video memory using Dynamic Video Memory Technology (DVMT).

AUDIO

- Sigmatel STAC 9767 codec
- Stereo headphone jack, 1 V_{rms} or less, minimum impedance 32 Ohms
- Mono microphone jack, 100 mV_{p-p} or less, minimum impedance 10K Ohms
- Two built-in stereo speakers, 20 mm diameter (Stereo)

MASS STORAGE DEVICE OPTIONS

Hard Drive

60GB, 40GB, or 30GB fixed hard drive, Ultra DMA 100, 2.5", 9.5mm

Media Player

Depending upon the configuration of your system, one of the following is installed.

- CD Drive (modular 24x maximum), or,
- DVD Drive (modular 8x maximum), or,
- Combo DVD/CD-RW (modular 8x maximum DVD/24x maximum write, 10x maximum rewrite, 24x maximum read CD-RW combo drive)

LifeBook S6000 Notebook

FEATURES**Integrated Pointing Device**

Touchpad pointing device with scroll button

Communications

Modem: Internal V.90 standard 56K fax/modem (ITU V.90, 56K data, 14.4K fax)

LAN: 10/100 Base-TX Ethernet

Wireless LAN:

S6000 Model - Integrated Intel PRO Wireless LAN (802.11b), Wi-Fi-compliant

S6000D Model - Optional integrated Atheros Wireless LAN (802.11g), Wi-Fi-compliant

LifeBook Security/Application Panel

The Application Launcher buttons on your LifeBook notebook default to the following applications:

Table 7-1 Application Launcher Defaults

Button Label	Button Function	Default Application
1	Application A	Notepad
2	Application B	Calculator
3	Internet	Internet Explorer
4	E-Mail	Netscape Messenger

Theft Prevention Lock

Lock slot for use with security restraint systems. The Kensington locking system is recommended.

DEVICE PORTS**On the LifeBook notebook:**

- PC Card slot for one Type I or Type II card: PCMCIA Standard 2.1 with CardBus support
- One 15-pin D-SUB connector for VGA external monitor (see Display specifications)
- Two USB 2.0 (Universal Serial Bus) connectors for input/output devices
- One IEEE 1394 (4-pin type) jack
- One stereo line-in jack
- One modular modem (RJ-11) connector
- One LAN (RJ-45) connector
- One stereo headphone jack. (See Audio specifications)
- One mono microphone jack. (See Audio specifications)
- Embedded Smart Card Reader (requires third-party application)
- Wireless LAN antenna with pre-installed on/off switch

On the Optional Port Replicator:

- One 6-pin mini DIN PS/2 compatible connectors for external keyboard, mouse or numeric keypad
- One 25-pin D-SUB connector for parallel input/output devices; Bi-directional, output only or ECP

- One 15-pin D-SUB connector for VGA external monitor (see Display specifications)
- One 9-pin D-SUB connector for RS-232C serial input/output devices
- Two USB 2.0 (Universal Serial Bus) connectors for input/output devices
- One LAN (RJ-45) connector

KEYBOARD

Built-in keyboard with all functions of 101 key PS/2 compatible keyboards.

- Total number of keys: 82
- Function keys: F1 through F12
- Feature extension key: Fn
- Two Windows keys: one Start key, one application key
- Key pitch: 19 mm
- Key stroke: 3 mm
- Built-in Touchpad pointing device with left and right buttons and scroll button.
- Built-in Palm Rest

External Keyboard Support

USB or PS/2-compatible (PS/2 compatible with Port Replicator only)

External Numeric Keypad Support

USB or PS/2-compatible (PS/2 compatible with Port Replicator only)

External Mouse Support

USB or PS/2-compatible (PS/2 compatible with Port Replicator only)

POWER**Batteries**

One 6-cell Lithium ion battery, rechargeable, 10.8V, 4000 mAh

Optional Flexible Bay battery: 6-cell Lithium ion battery, rechargeable, 10.8V, 3400 mAh

AC Adapter

Autosensing 100-240V AC, supplying 16V DC, 3.75A, 60W to the LifeBook notebook, Fujitsu Model FPCAC23AP, which includes an AC cable.

Power Management

Conforms to ACPI (Advanced Configuration and Power Interface).

WIRELESS LAN

Certain configurations of the Lifebook S6000 notebook have an optional Wireless LAN device installed. If you have an IntelPRO device installed, your system is classified as a Centrino product. If you have a Wireless LAN device other than IntelPRO installed, your system is classified as a Pentium M product. (For additional information about the Wireless LAN device, refer to the *Wireless LAN User's Guide* on page 93).

Specifications

DIMENSIONS AND WEIGHT

Overall Dimensions

Approximately 11.5"(w) x 9.3"(d) x 1.34"/1.36"(h)
(293 mm x 236.5 mm x 34/34.5 mm)

Weights

Approximately 3.85 lbs (1.75 kg) with battery and weight saver.

Approximately 4.5 lbs (2.05 kg) with battery and DVD drive.

ENVIRONMENTAL REQUIREMENTS

Temperature

Operating: 41° to 95° F (5° to 35° C)

Non-operating: 5° to 140° F (-15° to 60° C)

Humidity

Operating: 20% to 85%, relative, non-condensing

Non-operating: 8% to 85%, relative, non-condensing

Altitude

Operating: 10,000 feet (3,048 m) maximum

POPULAR ACCESSORIES

For ordering or additional information on Fujitsu accessories please visit our Web site at www.fujitsupc.com or call 1-800-733-0884.

Memory Upgrades

- 256MB SDRAM
- 512MB SDRAM

Docking

- Port Replicator

Power

- Main Lithium ion battery
- Battery Charger
- Auto/Airline Adapter
- AC Adapter

PC Cards

- Wireless PC Card

Additional Accessories

- Wireless Keyboard and Mouse
- External USB Floppy Disk Drive
- Presentation Audio System
- TeleAdapt 16' TeleCord
- Notebook Guardian Lock
- IBM Modem Saver

Carrying Cases

- Diplomat
- Backpack
- Director
- MobileMax Wheeled Case

Table 7-2 Pre-Installed Software

Software	Operating System Applicability		
	Windows 2000 Professional	Windows XP Professional	Windows XP Home
Adobe Acrobat Reader	X	X	X
Drive Image Special Edition (DISE)	X	X	X
EarthLink 5.0	X	X	X
BatteryAid	X		
Fujitsu HotKey		X	X
LifeBook Security/ Application Panel	X	X	X
Symantec Norton AntiVirus (90-day free trial)	X	X	X
Netscape 7	X	X	X
Quicken 2003 New User Edition		X	X
Microsoft Works 7.0		X	X
MS Reader*	X	X	X
Journal Viewer*	X	X	X
Zinio™ Reader*	X	X	X
Newsstand™ Reader*	X	X	X

* Indicates that the software is available for user installation in the "third-party software".

PRE-INSTALLED SOFTWARE

Depending on your pre-installed operating system, your Fujitsu LifeBook notebook comes with pre-installed software for playing audio and video files of various formats. In addition there is file transfer software, virus protection software and Power Management software. Refer to Table 7-2 for the pre-installed software associated with your operating system.

LEARNING ABOUT YOUR SOFTWARE

Tutorials

All operating systems and most application software have tutorials built into them upon installation. We highly recommend that you step through the tutorial before you use an application.

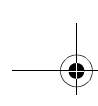

Manuals

Included with your notebook you will find manuals for your installed operating system and other pre-installed software. Any manuals that are not included, are available online through the help system of the software. We recommend that you review these manuals for general information on the use of these applications.

Adobe Acrobat Reader

The Adobe Acrobat Reader, located in the Service and Support Software folder, allows you to view, navigate, and print PDF files from across all of the major computing platforms.

BatteryAid (Windows 2000 only)

BatteryAid allows you to control the display brightness of your notebook in order to maximize battery life. (See your *BatteryAid online help for more information on the correct way to use this program*)

Drive Image Special Edition (DISE) by PowerQuest

DISE by PowerQuest provides a way to restore your computer if you experience a hard disk crash or other system failure. DISE is used to restore the factory image and restore the system to its original state.

Earthlink 5.0

Software suite that allows you to connect with the Internet.

Fujitsu HotKey (Windows XP only)

Fujitsu HotKey allows you to control the display brightness of your notebook in order to maximize battery life.

Quicken New User Edition (Windows XP only)

Quicken New User Edition by Intuit is a personal money management program. It has features such as portfolio management, account registries, on-line banking and bill paying features. This application is for new users who are using Quicken software for the first time. Full version upgrade information is available on line.

LifeBook Security/Application Panel Software

Your LifeBook notebook is pre-installed with software utilities that let you operate and configure your LifeBook Security/Application Panel.

The Security Panel portion allows for password protection while the system is off or in Suspend mode. The Security Panel utilities are found under the Start menu, under Programs, then under LifeBook Security Panel.

The Application Panel utilities are found under the Start menu, Settings/Control Panel, then Application Panel. To open the CD Player and Application Panel Help, select Start, Programs, LifeBook Application Panel.

Symantec Norton AntiVirus

Your system is preinstalled with a free 90-day trial version of Symantec's Norton AntiVirus™ 2003. Norton AntiVirus is a program designed to protect your LifeBook notebook from computer viruses. It assists in the protection of the data currently residing on your hard disk from destruction or contamination. The 90-day trial version is activated upon your acceptance of software license agreement. After 90 days, it will be necessary to purchase a subscription from Symantec to download latest virus definitions.

Netscape 7 by Netscape Communications Corp.

Browser suite, including integrated E-mail accounts, instant messaging, address book, search, and other tools and plug-ins.

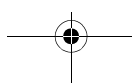

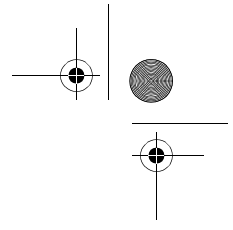
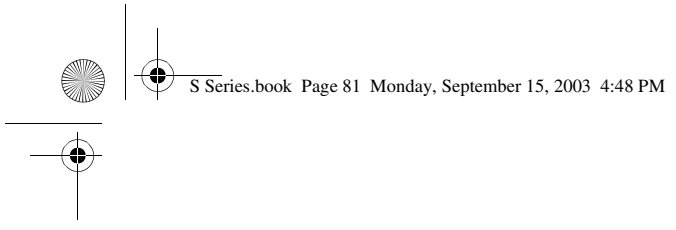

8 Glossary

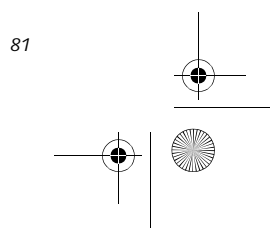
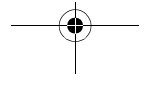
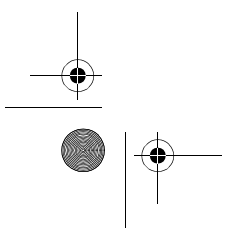
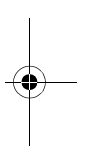
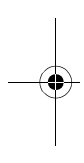

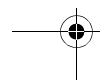
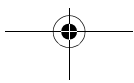
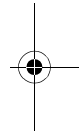
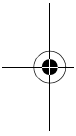
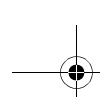

Glossary

AC Adapter

A device which converts the AC voltage from a wall outlet to the DC voltage needed to power your LifeBook notebook.

ACPI

Advanced Configuration and Power Interface

Active-Matrix Display

A type of technology for making flat-panel displays which has a transistor or similar device for every pixel on the screen.

AdHoc

A name of a wireless LAN configuration.

It is a type of communication using wireless cards only.

Another type of communication is called Infrastructure (using a wireless card and an access point).

ADSL

Asymmetric Digital Subscriber Line

Technology for transporting high bit-rate services over ordinary phone lines.

AGP

Accelerated Graphics Port

Graphics port specifically designed for graphics-intensive devices, such as video cards and 3D accelerators.

Auto/Airline Adapter

A device which converts the DC voltage from an automobile cigarette lighter or aircraft DC power outlet to the DC voltage needed to power your LifeBook notebook.

BIOS

Basic Input-Output System. A program and set of default parameters stored in ROM which tests and operates your LifeBook notebook when you turn it on until it loads your installed operating system from disk. Information from the BIOS is transferred to the installed operating system to provide it with information on the configuration and status of the hardware.

Bit

An abbreviation for binary digit. A single piece of information which is either a one (1) or a zero (0).

bps

An abbreviation for bits per second. Used to describe data transfer rates.

Boot

To start-up a computer and load its operating system from disk, ROM or other storage media into RAM.

Bus

An electrical circuit which passes data between the CPU and the sub-assemblies inside your LifeBook notebook.

Byte

8 bits of parallel binary information.

Cache Memory

A block of memory built into the micro-processor which is much faster to access than your system RAM and used in specially structured ways to make your overall data handling time faster.

CardBus

A faster, 32-bit version of the PC Card interface which offers performance similar to the 32-bit PCI architecture.

CD-ROM

Compact disk read only memory. This is a form of digital data storage which is read optically with a laser rather than a magnetic head. A typical CD-ROM can contain about 600MB of data and is not subject to heads crashing into the surface and destroying the data when there is a failure nor to wear from reading.

Channel

A radio frequency band used for communication between wireless cards and access points.

CMOS RAM

Complementary metal oxide semiconductor random access memory. This is a technology for manufacturing random access memory which requires very low levels of power to operate.

COM Port

Abbreviation for communication port. This is your serial interface connection.

Command

An instruction which you give your operating system. Example: run a particular application or format a floppy disk.

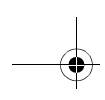

Configuration

The combination of hardware and software that makes up your system and how it is allocated for use.

CRT

Cathode Ray Tube. A display device which uses a beam of electronic particles striking a luminescent screen. It produces a visual image by varying the position and intensity of the beam.

Data

The information a system stores and processes.

DC

Direct current. A voltage or current that does not fluctuate periodically with time.

Default Value

A pre programmed value to be used if you fail to set your own.

DHCP

Dynamic Host Configuration Protocol

A protocol used to automatically acquire parameters required for the communication, such as IP address.

The sender of IP address is called a DHCP server, and the receiver is called a DHCP client.

DIMM

Dual-in-line memory module.

DISE

Drive Image Special Edition.

A utility that allows you to restore the original factory image on your hard drive in the event of corruption or accidental erasure of files or applications.

Disk

A spinning platter of magnetic data storage media. If the platter is very stiff it is a hard drive, if it is highly flexible it is a floppy disk, if it is a floppy disk in a hard housing with a shutter it is commonly called a diskette.

Disk Drive

The hardware which spins the disk and has the heads and control circuitry for reading and writing the data on the disk.

Diskette

A floppy disk in a hard housing with a shutter.

DMA

Direct Memory Access. Special circuitry for memory to memory transfers of data which do not require CPU action.

DMI

Desktop Management Interface. A standard that provides PC management applications with a common method of locally or remotely querying and configuring PC computer systems, hardware and software components, and peripherals.

DNS

Domain Name System

A function to control the association between the IP address and the name assigned to the computer.

If you do not know the IP address but if you know the computer name, you can still communicate to that computer.

DOS

Disk Operating System (MS-DOS is a Microsoft Disk Operating System).

Driver

A computer program which converts application and operating system commands to external devices into the exact form required by a specific brand and model of device in order to produce the desired results from that particular equipment.

DVMT

Dynamic Video Memory Technology

A video memory architecture that increases the efficiency of the motherboard by using innovative memory utilization and direct AGP.

ECP

Extended Capability Port. A set of standards for high speed data communication and interconnection between electronic devices.

Encryption Key (Network Key)

Key information used to encode data for data transfer.

This device uses the same encryption key to encode and decode the data, and the identical encryption key is required between the sender and receiver.

ESD

Electro-Static Discharge. The sudden discharge of electricity from a static charge which has built-up slowly.

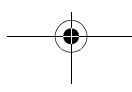
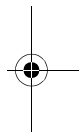
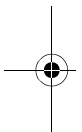

Example: the shock you get from a doorknob on a dry day or the sparks you get from brushing hair on a dry day.

Extended Memory

All memory more than the 640KB recognized by MS-DOS as system memory.

FCC

Federal Communication Commission.

Floppy Disk

A spinning platter of magnetic data storage media which is highly flexible.

GB

Gigabyte.

Hard drive

A spinning platter of magnetic data storage media where the platter is very stiff.

I/O

Input/Output. Data entering and leaving your notebook in electronic form.

I/O Port

The connector and associated control circuits for data entering and leaving your notebook in electronic form.

IDE

Intelligent Drive Electronics. A type of control interface for a hard drive which is inside the hard drive unit.

Infrared

Light just beyond the red portion of the visible light spectrum which is invisible to humans.

Infrastructure

A name of a wireless LAN configuration. This type of communication uses an access point.

Another type of communication is called AdHoc.

IP Address

An address used for computers to communicate in the TCP/IP environment.

Current IPv4 (version 4) uses four values in the range between 1 and 255. (Example: 192.168.100.123).

There are two types of IP address: global address and private address.

The global address is an only address in the world. It is controlled by JPNIC (Japan Network Information

Center). A private address is an only address in the closed network.

IR

An abbreviation for infrared.

IrDA

Infrared Data Association. An organization which produces standards for communication using infrared as the carrier.

IRQ

Interrupt Request. An acronym for the hardware signal to the CPU that an external event has occurred which needs to be processed.

KB

Kilobyte.

LAN

Local Area Network. An interconnection of computers and peripherals within a single limited geographic location which can pass programs and data amongst themselves.

LCD

Liquid Crystal Display. A type of display which makes images by controlling the orientation of crystals in a crystalline liquid.

Lithium ion Battery

A type of rechargeable battery which has a high power-time life for its size and is not subject to the memory effect as Nickel Cadmium batteries.

LPT Port

Line Printer Port. A way of referring to parallel interface ports because historically line printers were the first and latter the most common device connected to parallel ports.

MAC Address

Media Access Control Address

A unique physical address of a network card. For Ethernet, the first three bytes are used as the vendor code, controlled and assigned by IEEE. The remaining three bytes are controlled by each vendor (preventing overlap), therefore, every Ethernet card is given a unique physical address in the world, being assigned with a different address from other cards. For Ethernet, frames are sent and received based on this address.

MB

Megabyte.

Megahertz

1,000,000 cycles per second.

Memory

A repository for data and applications which is readily accessible to your LifeBook notebook's CPU.

MHz

Megahertz.

MIDI

Musical Instrument Digital Interface. A standard communication protocol for exchange of information between computers and sound producers such as synthesizers.

Modem

A contraction for MOdulator-DEModulator. The equipment which connects a computer or other data terminal to a communication line.

Monaural

A system using one channel to process sound from all sources.

MPU-401

A standard for MIDI interfaces and connectors.

MTU

Maximum Transmission Unit

The maximum data size that can be transferred at a time through the Internet or other networks. You can set a smaller MTU size to obtain successful communication, if you have difficulty transferring data due to the fact that the maximum size is too large.

Norton AntiVirus

Web-based software that protects you email, instant messages, and other files by removing viruses, worms, and Trojan horses.

NTSC

National TV Standards Commission. The standard for TV broadcast and reception for the USA.

Operating System

A group of control programs that convert application commands, including driver programs, into the exact form required by a specific brand and model of micro-processor in order to produce the desired results from that particular equipment.

Partition

A block of space on a hard drive which is set aside and made to appear to the operating system as if it were a separate disk, and addressed by the operating system accordingly.

PCI

Peripheral Component Interconnect

Self-configuring PC local bus. Designed by Intel, PCI has gained wide acceptance as a standard bus design.

PCMCIA

PCMCIA is a trademark of the Personal Computer Memory Card International Association. The Personal Computer Memory Card International Association is an organization that sets standards for add-in cards for personal computers.

Peripheral Device

A piece of equipment which performs a specific function associated with but not integral to a computer. Examples: a printer, a modem, a CD-ROM.

Pitch (keyboard)

The distance between the centers of the letter keys of a keyboard.

Pixel

The smallest element of a display, a dot of color on your display screen. The more pixels per area the clearer your image will appear.

POST

Power On Self Test. A program which is part of the BIOS which checks the configuration and operating condition of your hardware whenever power is applied to your notebook. Status and error messages may be displayed before the operating system is loaded. If the self test detects failures that are so serious that operation can not continue, the operating system will not be loaded.

PPPoE

Point to Point Protocol over Ethernet.

A protocol for Ethernet, using a Point-to-Point Protocol (PPP), which is used for connection on the phone line.

Program

An integrated set of coded commands to your computers telling your hardware what to do and how and when to do it.

Protocol

Glossary

Procedures and rules use to send and receive data between computers.

- Method of sending and receiving data
- Process used to handle communication errors

Conditions required for communication are organized in procedures for correct transfer of information.

RAM

Random Access Memory. A hardware component of your LifeBook notebook that holds binary information (both program and data) as long as it has the proper power applied to it.

RAM Module

A printed circuit card with memory and associated circuitry which allows the user to add additional memory to the computer without special tools.

Reset

The act of reloading the operating system. A reset erases all information stored in RAM.

Restart

See Reset.

Resume

To proceed after interruption. In your notebook this refers to returning to active operation after having been in one of the suspension states.

ROM

Read Only Memory. A form of memory in which information is stored by physically altering the material. Data stored in this way can not be changed by your notebook and does not require power to maintain it.

SDRAM

Synchronous Dynamic Random Access Memory.

Serial Port

A connection to another device through which data is transferred one bit at a time on a single wire with any other wires only for control of the device not for transfer of data.

SMART

Self-Monitoring, Analysis and Reporting Technology (SMART) is an emerging technology that provides near-term failure predictions for hard drives. When SMART is enabled the hard drive monitors pre-determined drive attributes that are susceptible to degradation over time. If a failure is likely to occur, SMART makes a status

report available so that the LifeBook notebook can prompt the user to back up the data on the drive. Naturally not all failures are predictable. SMART predictability is limited to those attributes which the drive can self-monitor. In those cases where SMART can give advance warning, a considerable amount of precious data can be saved.

SRAM

Static random access memory. A specific technology of making RAM which does not require periodic data refreshing.

SSID

Service Set Identifier

Specifies which network you are joining. Some systems allow you to specify any SSID as an option so you can join any network.

Standby

To make inoperative for a period of time. Your LifeBook notebook uses various suspension states to reduce power consumption and prolong the charge of your battery.

Status Indicator

A display which reports the condition of some portion of your hardware. On your LifeBook notebook this is an LCD screen just above the keyboard.

Stereo (audio)

A system using two channels to process sound from two different sources.

SVGA

Super VGA.

S-Video

Super Video. A component video system for driving a TV or computer monitor.

System Clock

An oscillator of fixed precise frequency which synchronizes the operation of the system and is counted to provide time of day and date.

TCP/IP

Transmission Control Protocol/Internet Protocol. A standard Internet protocol that is most widely used.

TFT

Thin Film Transistor – A technology for flat display panels which uses a thin film matrix of transistors to control each pixel of the display screen individually.

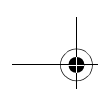

UL

Underwriters Laboratories – An independent organization that tests and certifies the electrical safety of devices.

USB

Universal Serial Bus.
Standard that allows you to simultaneously connect up to 127 USB devices such as game pads, pointing devices, printers, and keyboards to your computer.

VGA

Video Graphics Array. A video display standard originally introduced by IBM with the PS/2 series of personal computers.

VRAM

Video Random Access Memory. A memory dedicated to video display data and control.

WFM

Wired for Management is Intel's broad-based initiative to reduce the total cost of ownership (TCO) of business computing without sacrificing power and flexibility.

Wi-Fi Compatible

Wi-Fi (Wireless Fidelity) Identifies that the product has passed the interoperability test, supplied by the WECA (Wireless Ethernet Compatibility Alliance), which guarantees the interoperability of wireless IEEE 802.11 LAN products. For more information on the Wi-Fi standard, go to the WECA Web site at: www.wirelessethernet.com.

WLAN

Wireless Local Area Network. A wireless interconnection of computers and peripherals within a single limited geographic location which can pass programs and data amongst themselves.

Write Protect

Prevent alteration of the binary state of all bits in a storage media. Example: all information on a device such as a floppy diskette; a block of space in a storage media such as a partition of a hard drive; a file or directory of floppy diskette or hard drive.

XGA

Extended VGA.

Zip Drive

A 100MB or 250MB read/write removable media disk drive.

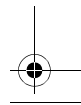
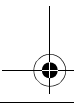
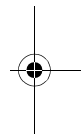
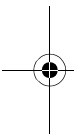

Regulatory Information

NOTICE

Changes or modifications not expressly approved by Fujitsu could void this user's authority to operate the equipment.

FCC NOTICES

Notice to Users of Radios and Television

These limits are designed to provide reasonable protection against harmful interference in a residential installation. This equipment generates, uses, and can radiate radio frequency energy and, if not installed and used in accordance with the instructions, may cause harmful interference to radio communications. However, there is no guarantee that interference will not occur in a particular installation. If this equipment does cause harmful interference to radio or television reception, which can be determined by turning the equipment off and on, the user is encouraged to try to correct the interference by one or more of the following measures:

- Reorient or relocate the receiving antenna.
- Increase the separation between the equipment and receiver.
- Connect the equipment into an outlet that is on a different circuit than the receiver.
- Consult the dealer or an experienced radio/TV technician for help.

Shielded interconnect cables must be employed with this equipment to ensure compliance with the pertinent RF emission limits governing this device.

Notice to Users of the US Telephone Network

This equipment complies with Part 68 of the FCC rules, and the requirements adopted by ACTA. On the bottom of this equipment is a label that contains, among other information, the FCC registration number and ringer equivalence number (REN) for this equipment; or a product identifier in the format US:AAAEQ##TXXXX. If requested, this information or number must be provided to the telephone company.

This equipment is designed to be connected to the telephone network or premises wiring using a standard jack type USOC RJ11C. A plug and jack used to connect this equipment to the premises wiring and telephone network must comply with the applicable FCC Part 68 rules and requirements adopted by the ACTA. A compliant telephone cord and modular plug is provided with this product. It is designed to be connected to a compatible modular jack that is also compliant.

The ringer equivalent number (REN) of this equipment is 0.0B as shown on the label. The REN is used to determine the number of devices that may be connected to a telephone line. Excessive RENs on a telephone may result in the devices not ringing in response to an incoming call. In most but not all areas, the sum of RENs should not exceed five (5.0). To be certain of the number of devices that may be connected to a line, as determined by the total RENs, contact the local telephone company.

If this equipment causes harm to the telephone network, the telephone company will notify you in advance that temporary discontinuance of service may be required. But if advance notice isn't practical, the telephone company will notify the customer as soon as possible. Also, you will be advised of your right to file a complaint with the FCC if you believe it is necessary.

The telephone company may make changes in its facilities, equipment, operations or procedures that could effect the operation of the equipment. If this happens the telephone company will provide advance notice in order for you to make necessary modifications to maintain uninterrupted service.

If trouble is experienced with this equipment, for repair or warranty information, please refer to the manual or contact Fujitsu PC Corporation, Customer Service. If the equipment is causing harm to the telephone network, the telephone company may request that you disconnect the equipment until the problem is resolved.

The equipment cannot be used on public coin service provided by the telephone company. Connection to party line service is subject to state tariffs. (Contact the state public utility commission, public service commission or corporation commission for information).

If your home has specially wired alarm equipment connected to the telephone line, ensure the installation of this computer does not disable your alarm equipment. If you have any questions about what will disable alarm equipment, consult your telephone company or a qualified installer.

The Telephone Consumer Protection Act of 1991 makes it unlawful for any person to use a computer or other electronic device to send any message via a telephone fax machine unless such message clearly contains in a margin at the top or bottom of each transmitted page or on the first page of the transmission, the date and time it is sent and an identification of the business or other entity, or other individual sending the message and the telephone number of the sending machine or such business, other entity, or individual.

LifeBook S6000 Notebook

DOC (INDUSTRY CANADA) NOTICES
Notice to Users of Radios and Television

This Class B digital apparatus meets all requirements of Canadian Interference-Causing Equipment Regulations.

CET appareil numérique de la class B respecte toutes les exigences du Règlement sur le matériel brouilleur du Canada.

Notice to Users of the Canadian Telephone Network

NOTICE: This equipment meets the applicable Industry Canada Terminal Equipment Technical Specifications. This is confirmed by the registration number. The abbreviation, IC, before the registration number signifies that registration was performed based on a Declaration of Conformity indicating that Industry Canada technical specifications were met. It does not imply that Industry Canada approved the equipment.

Before connecting this equipment to a telephone line the user should ensure that it is permissible to connect this equipment to the local telecommunication facilities. The user should be aware that compliance with the certification standards does not prevent service degradation in some situations.

Repairs to telecommunication equipment should be made by a Canadian authorized maintenance facility. Any repairs or alterations not expressly approved by Fujitsu or any equipment failures may give the telecommunication company cause to request the user to disconnect the equipment from the telephone line.

NOTICE: The Ringer Equivalence Number (REN) for this terminal equipment is 0.0. The REN assigned to each terminal equipment provides an indication of the maximum number of terminals allowed to be connected to a telephone interface. The termination on an interface may consist of any combination of devices subject only to the requirement that the sum of the Ringer Equivalence Numbers of all the devices does not exceed five.

 **CAUTION**

For safety, users should ensure that the electrical ground of the power utility, the telephone lines and the metallic water pipes are connected together. Users should NOT attempt to make such connections themselves but should contact the appropriate electric inspection authority or electrician. This may be particularly important in rural areas.

Avis Aux Utilisateurs Du Réseau Téléphonique Canadien

AVIS: Le présent matériel est conforme aux spécifications techniques d'Industrie Canada applicables au matériel terminal. Cette conformité est confirmée par le numéro d'enregistrement. Le sigle IC, placé devant le numéro d'enregistrement, signifie que l'enregistrement s'est effectué conformément à une déclaration de conformité et indique que les spécifications techniques d'Industrie Canada ont été respectées. Il n'implique pas qu'Industrie Canada a approuvé le matériel.

Avant de connecter cet équipement à une ligne téléphonique, l'utilisateur doit vérifier s'il est permis de connecter cet équipement aux installations de télécommunications locales. L'utilisateur est averti que même la conformité aux normes de certification ne peut dans certains cas empêcher la dégradation du service.

Les réparations de l'équipement de télécommunications doivent être effectuées par un service de maintenance agréé au Canada. Toute réparation ou modification, qui n'est pas expressément approuvée par Fujitsu, ou toute défaillance de l'équipement peut entraîner la compagnie de télécommunications à exiger que l'utilisateur déconnecte l'équipement de la ligne téléphonique.

AVIS: L'indice d'équivalence de la sonnerie (IES) du présent matériel est de 0.0. L'IES assigné à chaque dispositif terminal indique le nombre maximal de terminaux qui peuvent être raccordés à une interface téléphonique. La terminaison d'une interface peut consister en une combinaison quelconque de dispositifs, à la seule condition que la somme d'indices d'équivalence de la sonnerie de tous les dispositifs n'excède pas 5.

 **AVERTISSEMENT**

Pour assurer la sécurité, les utilisateurs doivent vérifier que la prise de terre du service d'électricité, les lignes téléphoniques et les conduites d'eau métalliques sont connectées ensemble. Les utilisateurs NE doivent PAS tenter d'établir ces connexions eux-mêmes, mais doivent contacter les services d'inspection d'installations électriques appropriés ou un électricien. Ceci peut être particulièrement important en régions rurales.

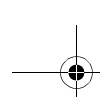

Regulatory Information

UL Notice

This unit requires an AC adapter to operate. Use only UL Listed Class 2 Adapters with an output rating of 16 VDC, with a current of 3.75 A.

AC Adapter output polarity:



CAUTION

The modem-to-telephone network connection must be a line cord using a minimum #26 AWG wire.

For Authorized Repair Technicians Only

WARNINGS

- For continued protection against risk of fire, replace only with the same type and rating fuse.
- Danger of explosion if Lithium (clock) battery is incorrectly replaced. Replace only with the same or equivalent type recommended by the manufacturer. Dispose of used batteries according to the manufacturer's instruction.

System Disposal



LAMP(S) INSIDE THIS PRODUCT CONTAIN MERCURY AND MUST BE RECYCLED OR DISPOSED OF ACCORDING TO LOCAL, STATE, OR FEDERAL LAWS.



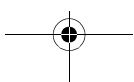
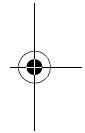
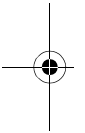
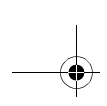

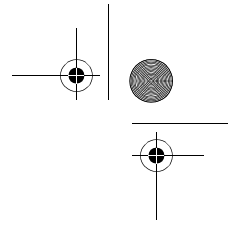
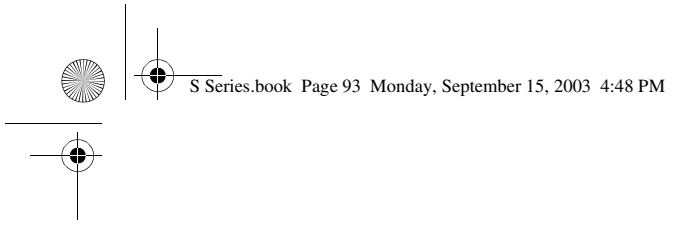

Appendix

Integrated Wireless LAN* User's Guide

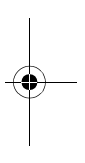
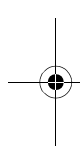

* Optional device

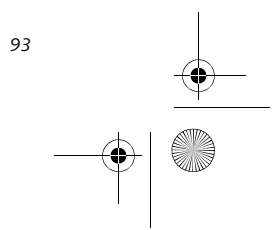
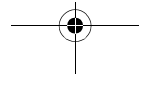
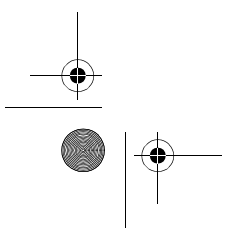

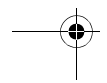
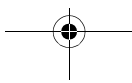
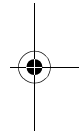
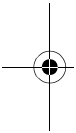
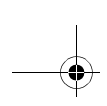

FC FCC REGULATORY INFORMATION

Please note the following regulatory information related to the optional wireless LAN device.

Regulatory Notes and Statements

Wireless LAN, Health and Authorization for use

Radio frequency electromagnetic energy is emitted from Wireless LAN devices. The energy levels of these emissions, however, are far much less than the electromagnetic energy emissions from wireless devices such as mobile phones. Wireless LAN devices are safe for use by consumers because they operate within the guidelines found in radio frequency safety standards and recommendations. The use of Wireless LAN devices may be restricted in some situations or environments, such as:

- On board an airplane, or
- In areas in which volatile gases are present, or
- In situations where the interference risk to other devices or services is perceived or identified as harmful.

In cases in which the policy regarding use of Wireless LAN devices in specific environments is not clear (e.g., airports, hospitals, chemical/oil/gas industrial plants, private buildings), obtain authorization to use these devices prior to operating the equipment.

Regulatory Information/Disclaimers

Installation and use of this Wireless LAN device must be in strict accordance with the instructions included in the user documentation provided with the product. Any changes or modifications made to this device that are not expressly approved by the manufacturer may void the user's authority to operate the equipment. The Manufacturer is not responsible for any radio or television interference caused by unauthorized modification of this device, or the substitution or attachment of connecting cables and equipment other than those specified by the manufacturer. It is the responsibility of the user to correct any interference caused by such unauthorized modification, substitution or attachment. The Manufacturer and its authorized resellers or distributors will assume no liability for any damage or violation of government regulations arising from failure to comply with these guidelines.

Federal Communications Commission statement

This device complies with Part 15 of FCC Rules.

Operation is subject to the following two conditions: (1) This device may not cause interference, and, (2) This device must accept any interference, including interference that may cause undesired operation of this device.

FCC Interference Statement

This equipment has been tested and found to comply with the limits for a Class B digital device, pursuant to Part 15 of the FCC Rules. These limits are designed to provide reasonable protection against harmful interference in a residential installation. This equipment generates, uses, and can radiate radio frequency energy. If not installed and used in accordance with the instructions, it may cause harmful interference to radio communications. However, there is no guarantee that interference will not occur in a particular installation.

If this equipment does cause harmful interference to radio or television reception, which can be determined by turning the equipment off and on, the user is encouraged to try and correct the interference by one or more of the following measures:

1. Reorient or relocate the receiving antenna.
2. Increase the distance between the equipment and the receiver.
3. Connect the equipment to an outlet on a circuit different from the one the receiver is connected to.
4. Consult the dealer or an experienced radio/TV technician for help.

FCC Radio Frequency Exposure statement

This Wireless LAN radio device has been evaluated under FCC Bulletin OET 65C and found compliant with the requirements as set forth in CFR 47 Sections 2.1091, 2.1093, and 15.247 (b) (4) addressing RF Exposure from radio frequency devices. The radiated output power of this Wireless LAN device is far below the FCC radio frequency exposure limits. Nevertheless, this device shall be used in such a manner that the potential for human contact during normal operation is minimized. When using this device, a certain separation distance between antenna and nearby persons must be maintained to ensure RF exposure compliance. In order to comply with RF exposure limits established in the ANSI C95.1 standards, the distance between the antennas and the user should not be less than 20 cm (8 inches).

Export restrictions

This product or software contains encryption code which may not be exported or transferred from the US or Canada without an approved US Department of Commerce export license. This device complies with Part 15 of FCC Rules., as well as ICES 003 B / NMB 003 B. Operation is subject to the following two conditions: (1) this device may not cause harmful interference, and (2) this device must accept any interference received, including interference that may cause undesirable operation. Modifications not expressly authorized by Fujitsu PC Corporation may invalidate the user's right to operate this equipment.

Before Using the Wireless LAN

The Integrated Wireless LAN is an optional device available for Fujitsu mobile computers. This manual describes the basic operating procedures for the Wireless LAN (referred to as the “device” in this manual) and how to set up a wireless LAN network. Before using this device, read this manual carefully to ensure correct operation of the device. Keep this manual in a safe place for reference while using the device.

Types of Wireless LANs Covered by this Document

This document is applicable to systems containing one of the following two devices. Most of the procedures are identical. Sections that differ between the two devices have been noted in the text:

- Intel PROSet Wireless LAN
- Atheros Wireless LAN

To determine which device is present in your system, click [Start] -> [Settings (Windows 2000 only)] -> Control Panel. If there is an icon named “Intel PROSet”, you have the Intel device; if there is an icon named “Atheros Wireless Utility”, you have the Atheros device.

Characteristics of the Device

This device consists of a wireless LAN card that is attached inside the computer via a mini-PCI slot.

The main characteristics are as follows:

- It operates in the 2.4 GHz Industrial, Scientific, and Medical (ISM) RF band.
- It does not require the procurement of an FCC license to operate.
- It uses Direct Sequence Spread Spectrum (DS-SS), an RF modulation scheme that is resistant to noise.

- This device complies with Wi-Fi, and is able to communicate at the maximum transfer rate of 11 Mbps (802.11b) or 54 Mbps (802.11g).
- The maximum communication range is approximately 80 feet (25 meters) inside a building. The range may be shorter depending upon the installation factors, such as walls and columns.
- Unauthorized access can be prevented with the use of an SSID and an encryption key (also known as a WEP key).

Wireless LAN Modes Using this Device

Ad Hoc Mode (See Figure 1)

“Ad Hoc Mode” refers to a type of wireless network that involves connecting multiple computers without the use of an Access Point. Network connectivity between computers can be established using only wireless LAN cards in a peer-to-peer fashion.

Ad Hoc networks are an easy and inexpensive method for establishing network connectivity between multiple computers.

In the Ad Hoc mode, you can use the function supported by Microsoft Network, such as File and Print Sharing to exchange files and share a printer or other peripheral devices.

To use the Ad Hoc Mode, you must set the same SSID and the same encryption key for all the computers that are connected. All connected computers can communicate with each other within the communication range.

Access Point (Infrastructure) Mode (See Figure 2)

If a number of computers are connected simultaneously in the Ad Hoc mode, the transfer rate may be reduced, communications may become unstable, or the network

Figure 1. Ad Hoc Mode Network

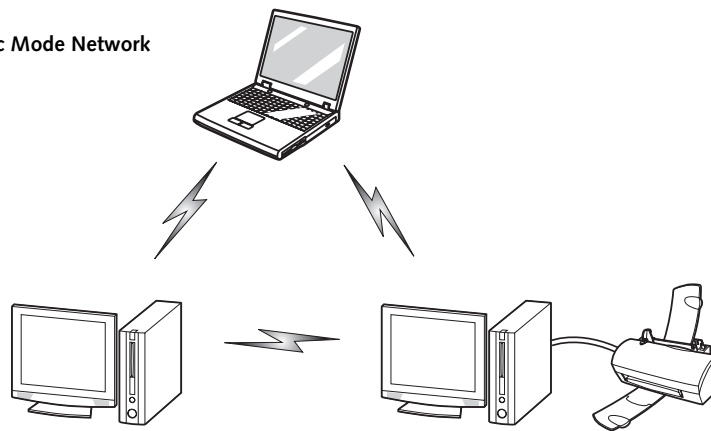
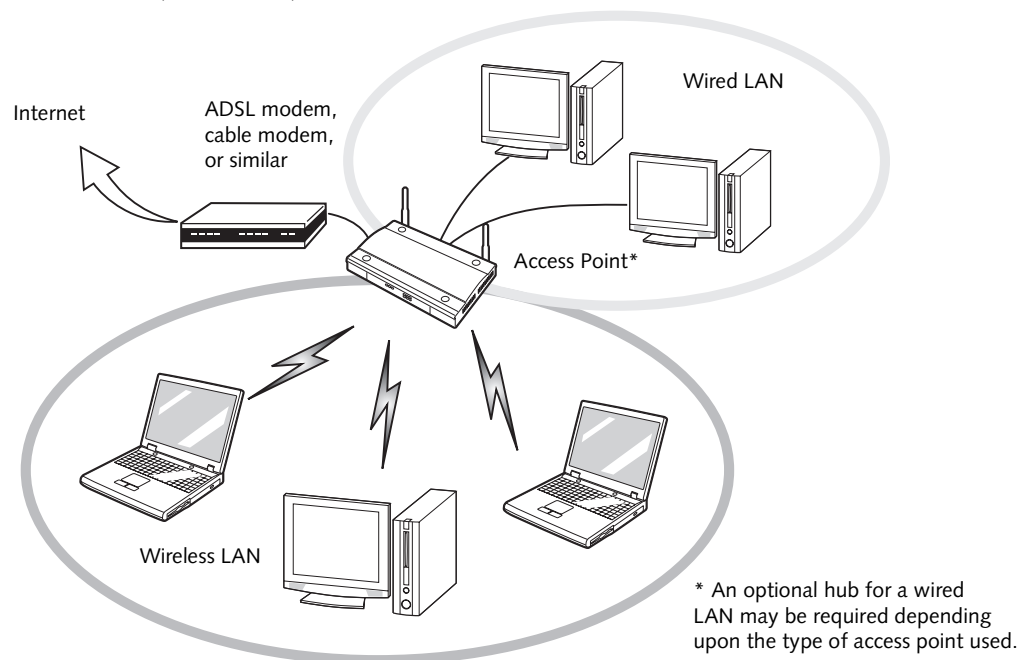

Figure 2. Access Point (Infrastructure) Mode Network



connection could fail. This is because all wireless LAN cards are using the same radio frequency in the network.

To improve this situation, you can use a wireless LAN access point, which is sold separately. The wireless LAN network is in the "Access Point mode" when it uses an access point, and such a connection is called the "Access Point Network" or "Infrastructure Network".

By using an access point, you can set and use a different communication channel for each network group. Each channel is given a different radio frequency, and it eliminates the collision of communications and provides a more stable communications environment.

How to Handle This Device

The Integrated Wireless LAN device is already installed in your mobile computer. Under normal circumstances, it should not be necessary for you to remove or re-install it. The LAN has been configured to support the operating system with which your system shipped.

FOR BETTER COMMUNICATIONS

This personal computer may not operate properly due to the operating environment. Strictly observe the following precautions when installing the main unit of the computer:

- Since this personal computer and equipment compliant with IEEE802.11a differ in operation frequency, it is not possible to communicate between both.

- The recommended wireless communications distance is within a line-of-sight radius of 25 meters. For reasons related to the characteristics of the wireless LAN, however, the actual communications distance depends on the structure of the building in which the wireless LAN function is to be used, the presence/absence of obstructions, the types of software to be used, installation status, radio-wave status, or other operating conditions. Decreases in communications speed or a communications failure may also occur.
- Distance the main unit of this personal computer is from other electric appliances. If the main unit of the person computer is installed near a powered-on electric appliance, the computer may not be able to communicate properly or trouble may occur in the electric appliance.
- If the computer is unable to communicate properly, change the channel to be used or the installation location. During the use of a microwave oven or other equipment generating strong high-frequency energy, in particular, the personal computer may be highly susceptible to the energy and unable to communicate properly.
- If a broadcasting station or wireless communications equipment is present nearby and this prevents the computer from communicating properly, moving the main unit of the computer is suggested. Radio interference may also occur if the intensity of ambient radio waves is too high.

STOPPING TRANSMISSION

To use this product inside hospitals, clinics, or airplanes, or in other places where the use of electronic equipment is regulated, stop the transmission of radio waves from the wireless LAN beforehand.

Deactivation using the wireless switch

The transmission of radio waves from the wireless LAN can be stopped by setting the wireless switch to the Off position. Note that the Wireless LAN On/Off switch has no effect on non-Wireless LAN models.

(See Figure 3 for Wireless LAN switch location.)

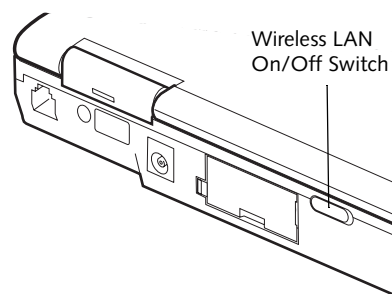

Figure 3. Wireless LAN On/Off Switch

Deactivation using Windows**Intel PROSet Wireless LAN:**

1. Click [Start] --> [(All) Programs] --> [Intel Network Adapters] --> [Intel(R) PROSet]. The Intel(R) PROSet window will be displayed.
2. Click the General tab.
3. Select [Off] for the wireless communications Switch Radio: function, and then click the [OK] button. Wireless communications on/off switching will be deactivated and the transmission of radio waves from the wireless LAN will be stopped.

POINT

To restart transmission, select [On] for the wireless communications Switch Radio: function, and then click the [OK] button.

Atheros Wireless LAN

1. Click [Start] --> [Settings (Windows 2000 only)] --> [Control Panel] --> [Atheros Wireless Utility]. The Atheros Wireless Configuration Utility window will be displayed.
2. Click the Wireless Networks tab.

3. Click the [Enable Radio] box to clear it, then click the [OK] button. Wireless communications on/off switching will be deactivated and the transmission of radio waves from the wireless LAN will be stopped.

POINT

To restart transmission, check the [Enable Radio] checkbox to select it., then click the [OK] button.

STARTING TRANSMISSION

To communicate using the wireless LAN function, set the computer to a status from which it can transmit, as follows:

Intel PROSet Wireless LAN:

1. Set the wireless switch to the On position.
2. Click [Start] --> [(All) Programs] --> [Intel Network Adapters] --> [Intel(R) PROSet]. The Intel(R) PROSet window will be displayed.
3. Click the [General] tab if it is not already selected.
4. Select [ON] for the Switch radio: function, then click [OK]. Wireless communications on/off switching will be activated and the transmission of radio waves will be restarted.

Atheros Wireless LAN:

1. Click the Wireless Network Connection icon in the system tray at the lower right of your screen.
2. Click [Enable Radio]. The radio will be turned on. **Access Point Mode:** Transmission is enabled. **Ad Hoc Mode:** Restart your computer to enable the radio.

Connection using Windows XP

FLOW OF OPERATIONS

The wireless LAN connection procedure contained in this section is outlined below.

1. Make sure the mobile computer is ready for the transmission of radio waves from the wireless LAN. For further details, see *(See Starting Transmission on page 98 for more information)*.
2. Assign the parameters required for wireless LAN connection. *(See Preparation for wireless LAN connection on page 99 for more information)*.
 - Enter the network name (SSID) and other data.
 - Enter the network key (the Wired Equivalent Privacy or WEP key used to encode 802.11b communications data).
3. Perform setting operations relating to network connection. *(See Connection to the network on page 101 for more information)*
 - Specify TCP/IP as the protocol, and confirm the name of the work group and other settings.
 - Enter the data required for file/printer sharing on the network. Perform this operation as required.
 - For access point (or "infrastructure") connection, enter data for the access point. Refer to the manual of the access point for further details.
 - Verify that you are able to connect your computer to the network.

PREPARATION FOR WIRELESS LAN CONNECTION

This section explains the preparations required for the use of the wireless LAN.

Assigning parameters

Enter the network name (SSID), the network key, and other data required for wireless LAN connection. If there is the administrator of the network, contact the network administrator for data settings.

POINT

- To use access point (infrastructure) connection, refer to the access point manual for the access point-setting procedure.
- You do not need to set the channel when using access point (infrastructure) mode. Channel selection is controlled by the access point. In ad hoc networks, channel selection defaults to channel 11; however, channel selection can be manually changed if desired. This can be accomplished only when using the client utility.

If it is necessary to change the channel, change the setting of the access point. For the setting procedure, refer to the manual of the access point.

1. Make sure the Wireless LAN switch is switched on.
2. Click the [Start] button first and then [Control Panel].
3. If the Control Panel is in Category view, switch to Classic view by clicking "Switch to Classic View" under Control Panel the left frame. (If you are already in Classic view, "Switch to Category View" will be displayed instead.)
4. Double-click the Network Connections icon. A list of currently installed networks will be displayed.
5. Right-click [Wireless Network Connection] in the list, and then click [Properties] in the menu displayed. The [Wireless Network Connection Properties] window will be displayed.
6. Click the [Wireless Networks] tab.
7. Click [Refresh], then choose the correct SSID from the [Available Networks] window. Click [Configure] and proceed to step 7. If the SSID of your access point does not appear in the list, click [Add]. The [Wireless Network Properties] window will be displayed.
8. Select the Association tab if it is not already selected.
9. Enter the information required for connection to the wireless LAN.
 - a. Enter the network name (SSID). (i.e., Enter the name of the desired network in less than 33 ASCII characters).

For ad hoc connection: Assign the same network name to all the personal computers to be connected.

For access point (infrastructure) connection: Assign the appropriate SSID. The SSID must be identical to the SSID of the access point. Refer to the access point manual, or contact your network administrator.

- b. **For ad hoc connection,** check the following field.
For access point (infrastructure) connection, clear the check mark for the following field:

[This is a computer-to-computer (ad hoc) network; wireless access points are not used.]

10. Enter the WEP key for encoding communications data.

CAUTION

It is strongly recommended that you enter the network key for encoding communications data. If the network key is not entered, since the network can be accessed from all personal computers containing the wireless LAN function, there is the danger of your data being stolen or damaged by other users.

- a. Check the [Data encryption (WEP enabled)] check box

For ad hoc connection: Clear the check mark from the [Network Authentication (Shared mode)] check box.

For access point (infrastructure) connection: If the access point to be accessed has acquired shared-key authentication, check the [Network Authentication (Shared mode)] check box.

For open-system authentication, clear the check mark. For access point setting, refer to the manual of the access point.

- b. Clear the check mark from the [The key is provided for me automatically] check box.
- c. Enter data in [Network Key]. Depending on the number of entered characters or digits, whether the key is an ASCII character code or a hexadecimal code will be identified automatically.
- Use five or thirteen characters to enter the key in the ASCII character code format. The characters that can be used as the “network key” are as follows: 0 - 9, A - Z, _ (underscore), or,
 - Use 10 or 26 characters to enter the key in the hexadecimal character code format. The characters that can be used as the “network key” in this case are as follows: 0- 9, A - Z, a - f

For ad hoc connection: Assign the same network key to all the personal computers to be connected.

For access point (infrastructure) connection: Assign the identical network key that is programmed into the access point. For this setting, refer to the access point manual or contact your network administrator.

- d. Confirm the Network key by re-entering the same data in the [Confirm network key:] field.
- e. Make sure that [Key index (advanced)] is set to “1”. (Any value from “1” to “4” can be assigned to [Key index (advanced)]. “1” is usually assigned, however).

11. Click the [Authentication] tab and then verify the settings of [Enable network access control using IEEE 802.11x].

For internal use at an organization such as a company, when access by wireless LAN clients is to be limited using IEEE 802.11x authentication, check the [Enable network access control using IEEE 802.11x] check box.

For home use, clear the check mark from [Enable network access control using IEEE 802.11x].

For the setting method relating to IEEE 802.11x authentication, refer to the manual of the access point which you are using.

12. After completion of setting operations, click the [OK] button. Processing will return to the [Wireless Network Connection Properties] window.
13. Verify that the network name entered in step 7 above is added in [Preferred Networks], and then click the [OK] button. Close the [Wireless Network] window.

POINT

In [Preferred Networks], register only the desired connection settings.

CONNECTION TO THE NETWORK

This section explains connection to the network.

If there is an administrator of the network, contact the network administrator for data settings.

Setting the network

Perform the "Setting TCP/IP" and "Confirming the computer and work group names" operations required for network connection.

Setting TCP/IP

POINT

To change the setting of the IP address, you need to be logged in from Windows as an administrator.

1. Click the [Start] button first and then [Control Panel].
2. If the Control Panel is in Category view, switch to Classic view by clicking "Switch to Classic View" under Control Panel the left frame. (If you are already in Classic view, "Switch to Category View" will be displayed.)
3. Double-click [Network Connections]. A list of currently installed networks will be displayed.
4. Right-click [Wireless Network Connection] in the list, and then click [Properties] in the menu displayed. The [Wireless Network Connection Properties] window will be displayed.
5. Click the [General] tab if it is not already selected.
6. Click [Internet Protocol (TCP/IP)] and then click [Properties]. The [Internet Protocol (TCP/IP) Properties] window will be displayed.
7. Set the IP address as follows:
 - **For ad hoc connection:** Select [Use the following IP address:] and then enter data for [IP address] and [Subnet mask]. See page 117 for IP address setting.
 - **For access point (infrastructure) connection:** If your network uses DHCP, select [Obtain an IP address automatically] and [Obtain DNS server address automatically]. If your network uses static IP addresses, consult with your network administrator for the correct IP address settings.
8. Click the [OK] button. Processing will return to the [Wireless Network Connection Properties] window.
9. Click the [OK] button.
10. Close the [Network Connection] window.

Following this operation, confirm the names of the computer and the workgroup as follows.

Confirming the computer and work group names

POINT

To modify the computer name and/or the work group name, you need to be logged in from Windows as an administrator.

1. Click the [Start] button, then [Control Panel].
2. If the Control Panel is in Category view, switch to Classic view by clicking "Switch to Classic View" under Control Panel the left frame. (If you are already in Classic view, "Switch to Category View" will be displayed.)
3. Double-click the [System] icon. The [System Properties] window will be displayed.
4. Click the [Computer Name] tab.
5. Confirm the settings of [Full computer name:] and [Workgroup:].
 - a. The setting of [Full computer name:] denotes the name for identifying the computer. Any name can be assigned for each personal computer.

POINT

To change the name, click [Change] and then proceed in accordance with the instruction messages displayed on the screen.

Enter the desired name in less than 15 ASCII character code format. Identifiability can be enhanced by entering the model number, the user name, and other factors.

- b. [Workgroup name] is the group name of the network. Enter the desired name in less than 15 ASCII character code format.

For ad hoc connection: Assign the same network name to all personal computers existing on the network.

For access point (infrastructure) connection: Assign the name of the work group to be accessed.

6. Click the [OK] button. If a message is displayed that requests you to restart the personal computer, click [Yes] to restart the computer.

Setting the sharing function

Set the sharing function to make file and/or printer sharing with other network-connected personal computers valid.

LifeBook S6000 Notebook

This operation is not required unless the sharing function is to be used.

The folder and printer for which the sharing function has been set will be usable from any personal computer present on the network.

POINT

To share a file and/or the connected printer, you need to be logged in as an administrator.

Setting the Microsoft network-sharing service

1. Click the [Start] button first and then [Control Panel].
2. If the Control Panel is in Category view, switch to Classic view by clicking "Switch to Classic View" under Control Panel the left frame. (If you are already in Classic view, "Switch to Category View" will be displayed.)
3. Double-click [Network Connections]. A list of currently installed networks will be displayed.
4. Right-click [Wireless Network Connection] in the list, and then click [Properties] in the menu displayed. The [Wireless Network Connection Properties] window will be displayed.
5. If [File and Printer Sharing for Microsoft Networks] is displayed, proceed to step 6. If [File and Printer Sharing for Microsoft Networks] is not displayed, skip to step 7.
6. Make sure that the [File and Printer Sharing for Microsoft Networks] check box is checked, and then click the [OK] button. Skip to "Setting file-sharing function".
7. Click [Install]. The [Select Network Component Type] window will be displayed.
8. Click [Service], then click the [Add] button. The [Select Network Service] window will be displayed.
9. Click [File and Printer Sharing for Microsoft Networks] and then click the [OK] button. Processing will return to the [Wireless Network Connection Properties] window, and [File and Printer Sharing for Microsoft Networks] will be added to the list.
10. Click the [Close] button.

Setting the file-sharing function

The procedure for setting the file-sharing function follows, with the "work" folder in drive C: as an example.

1. Click the [Start] button first and then [My Computer].
2. Double-click [Local disk (C:)].
3. Right-click the "work" folder (or whichever folder you want to share), and then click [Sharing and Security...] in the menu displayed. The [Folder Name Properties] window will be displayed.

POINT

Setting the file-sharing function for the file which has been used to execute Network Setup Wizard is suggested on the screen. For the wireless LAN, however, since security is guaranteed by entry of the network name (SSID) and the network key, the steps to be taken to set the file-sharing function easily without using Network Setup Wizard are given below.

4. Click [Sharing] if it isn't already selected.
5. Click the link stating "If you understand the security risks, but want to share files without running the wizard, click here".
6. Click "Just enable file sharing" and click [OK].
7. Check the [Share this folder on the network] check box.

POINT

To specify the corresponding folder as a read-only folder, select the [Read only] checkbox under the General tab.

8. Click the [OK] button. The folder will be set as a sharable folder, and the display of the icon for the "work." folder will change.

Setting the printer-sharing function

1. Click the [Start] button first and then [Printers and FAX]. A list of connected printers will be displayed.
2. Right-click the printer for which the sharing function is to be set, and then click [Sharing] in the menu displayed. The property window corresponding to the selected printer will be displayed.

POINT

Setting the printer-sharing function when Network Setup Wizard has been executed is suggested on the screen. For the wireless LAN, however, since security is guaranteed by entry of the network name (SSID) and the network key, the steps to be taken to set the printer-sharing function without using Network Setup Wizard are laid down below.

3. Click the [Sharing] tab.
4. Click [Share this printer].
5. Enter the sharing printer name in [Share name].
6. Click the [OK] button.

Confirming connection

After you have finished the network setup operations, access the folder whose sharing has been set for other personal computers. Also, confirm the status of the radio waves in case of trouble such as a network connection failure.

POINT

In the case of access point (infrastructure) connection, enter the necessary data for the access point before confirming connection. Refer to the manual of the access point for the access point setup procedure.

Connecting your personal computer to another personal computer

1. Click [Start] first and then [My Computer]. The [My Computer] window will be displayed in the left frame.
2. Click [My Network Places] in the "Other Places" list. The window [My Network Places] will be displayed.
3. Click [View workgroup computers] under Network Tasks in the left frame.
4. Double-click the personal computer to which your personal computer is to be connected. The folder that was specified in "Setting the file-sharing function" on page 102 will be displayed.
5. Double-click the folder to be accessed.

Confirming the status of the radio

Intel PROSet Wireless LAN:

1. Click [Start] -> [All Programs] -> [Intel Network Adapters] -> [Intel(R) PROSet]. The [Intel(R) PROSet] window will be displayed.
2. Click the [General] tab and confirm radio status in the window displayed. The current connection status will be displayed.
 - **Signal Quality**
The quality of the signals is displayed on a graph.
 - **Network name (SSID)**
The connected network name (SSID) is displayed.
 - **Profile name**
"<No profile>" is displayed.

- **Mode**
If access point (infrastructure) connection is in use, "Infrastructure (AP)" will be displayed. If ad hoc connection is in use, "Ad hoc (Peer-to-peer)" will be displayed.
- **Security**
The setting status of WEP is displayed.
- **Speed**
The communications speed is displayed.
- **Band (Frequency)**
The current operating frequency band is displayed. When communication is possible, "802.11b (2.4 GHz)" is displayed.
- **Channel**
The channel number currently being used for the communications is displayed.

If connection cannot be made to the network or if you want to check for normal connection, see "Troubleshooting" on page 112.

Atheros Wireless LAN:

1. Right-click the Atheros icon in the lower right corner of the screen.
2. Click [Open Client Utility]. The Atheros Wireless Configuration Utility window opens.
3. Contained within the Current Status tab and Advanced Current Status, you will find the current operating status of the radio. (When the radio is turned off or the computer is not yet connected, some of the conditions will not be displayed.)
 - **Profile Name**
The current configuration profile is displayed.
 - **Network Type - Configured Network Type**
[Access Point] or [AdHoc] will be displayed.
 - **Current Mode**
Indicates the frequency and data rate currently used by the radio.
 - **Current Channel**
The channel number currently used by the radio.
 - **Link Status**
Displays the current connected state of the WLAN module.
 - **Encryption Type**
Displays the encryption type currently used by the radio.
 - **IP Address**
Displays the current TCP/IP address assigned to the WLAN adapter.

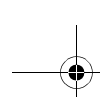

LifeBook S6000 Notebook

- **Country**
The country with the country code for which the radio is configured.
- **Transmit Power Level**
Displays the current transmit power level of the radio.
- **Network Name (SSID)**
Displays the Network Name (SSID) currently used by the radio.
- **Power Save Mode**
Displays the configured Power Save Mode currently used by the radio. [Off], [Normal], or [Maximum] will be displayed.
- **BSSID**
Displays the Basic Service Set Identifier. This is typically the MAC address of the Access Point or in the case of AdHoc networks, is a randomly generated MAC address.
- **Frequency**
Displays the center frequency currently being used by the radio.
- **Transmit Rate**
Displays the current data rate used by the radio to transmit data.
- **Receive Rate**
Displays the current data rate used by the radio to receive data.

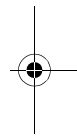
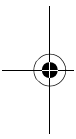

Connection using Windows 2000

FLOW OF OPERATIONS

The wireless LAN connection procedure is outlined below.

1. Make sure that the personal computer is ready for the transmission of radio waves from the wireless LAN. For further details, see "Starting the transmission" on page 98.
2. Assign the parameters required for wireless LAN connection. For further details, see "Preparation for wireless LAN connection" on page 99.
 - Enter the network name (SSID) and other data.
 - Enter the network key (the key to be used to encode communications data).
3. Perform setting operations relating to network connection. For further details, see "Connection to the network" on page 101.
 - Specify TCP/IP as the protocol, and confirm the name of the work group and other settings.
 - Enter the data required for file/printer sharing on the network. Perform this operation as required.
 - For access point (infrastructure) connection, enter data for the access point. Refer to the manual of the access point for further details.
 - Verify that you have been able to connect your computer to the network.

PREPARATION FOR WIRELESS LAN CONNECTION

This section explains the preparation (parameter assignment) required for the use of the wireless LAN.

Assigning parameters

Enter the network name (SSID), the network key, and other data required for wireless LAN connection. If there is the administrator of the network, contact the network administrator for data settings.

POINT

- To use access point (infrastructure) connection, refer to the access point manual for the access point-setting procedure.
- You do not need to set the channel when using access point (infrastructure) mode. Channel selection is controlled by the access point. In ad hoc networks, channel selection defaults to channel 11; however, channel selection can be manually changed if desired. This can be accomplished only when using the client utility.

If it is necessary to change the channel, change the setting of the access point. For the setting procedure, refer to the manual of the access point.

Intel PROSet Wireless LAN:

1. Click [Start] -> [Programs] -> [Intel Network Adapters] -> [Intel(R) PROSet]. The [Intel(R) PROSet] window will be displayed.
2. Click the [Networks] tab.
3. Click the [Add] button. The [Profile Wizard] window will be displayed.
4. Enter the information required for connection to the wireless LAN:
 - **Enter data in [Profile name]**
Enter the name of the system file for saving the parameter information that you are going to enter. Enter the desired character string consisting of less than 41 ASCII characters. Also, multiple [Profile] items can be created covering both ad hoc connection and access point (infrastructure) connection. When there are multiple wireless LANs to which your persona computer is to be connected, each LAN can be accessed by selective use of the profiles.
 - **Enter the network name (SSID)**
Enter the appropriate network name according to the "Operating mode" to be used. Enter the desired network name in less than 33 ASCII characters.

Access Point (Infrastructure) connection:

Select [Infrastructure - Connect to an access point] under "Operating mode", and assign the appropriate data according to the ID code of the

LifeBook S6000 Notebook

access point to be accessed. For access point setting, refer to the manual of the access point.

Ad hoc connection:

Select [Ad hoc - Connect directly to other computers] under "Operating mode", and assign the same network name to all the personal computers to be connected.

POINT

It is not necessary to enter data in the [Mandatory AP] link.

5. Click the [Next] button.
6. Set security as follows:
 - **Select [Network Authentication]**
This parameter is dependent on the WEP configuration of the access point and must be identical to the setting on the Access Point. Please consult your network administrator for proper configuration of this parameter.
[Open]: Select [Open] if you want open-system authentication or open-key authentication.
[Shared]: Select [Shared] if you want shared-key authentication.

POINT

Network authentication cannot be selected for ad hoc connection.

- **Select [Data encryption (WEP)]**
Specify the method of encoding communications data.
"None"
Encoding is not assigned.
"64-bit"
Specify the network key in a 64-bit format. Use either [Use pass phrase...] or [Use WEP Keys...] to enter the network key.
"128-bit"
Specify the network key in a 128-bit format. Use either [Use pass phrase...] or [Use WEP Keys...] to enter the network key.
If [Use pass phrase...] has been selected above, enter an ASCII character string consisting of five or thirteen characters. The characters that can be used for [Path phrase] are as follows:
0 - 9, A - Z, a - z

If [Use WEP Keys...] has been selected, enter a hexadecimal number consisting of 10 or 26 char-

acters. The characters that can be used for [Key] are as follows: 0 - 9, A - F

- **Select [Key index].**

For access point (infrastructure) connection:
Any number from "1" to "4" can be assigned to [Key index]. "1" is usually assigned.
For ad hoc connection:
[Key index] cannot be selected.

POINT

- **For access point (infrastructure) connection:**
WEP key entered here must be **identical** to the WEP key of all wireless LAN devices in the network in order for communication to take place. Please note: The WEP key generated by passphrases vary from manufacturer to manufacturer. It is recommended that entry of the WEP key be accomplished using the hexadecimal method of entry.
- **Be careful since the index number has the following relationship with respect to this personal computer:**

If the index number of the key is from 0 to 3, the index number corresponding to this personal computer is "0".

If the index number of the key is from 1 to 4, the index number corresponding to this personal computer is "1".

7. Click the [Finish] button. [Profile Wizard] will be terminated and the created profile added to [Profile List] of the [Networks] tab.
8. Select the created profile from [Profile List] and then click the [Connect] button. If other wireless LANs are present nearby or in the same floor of the building, it is suggested that the value of the channel be spaced by 5.

For access point (infrastructure) connection, setup is not required.

Atheros Wireless LAN:

1. Right-click the Atheros Wireless Utility icon in the system tray in the lower right corner of your screen.
2. Click [Open Client Utility]. The [Atheros Wireless Configuration Utility] window will be displayed.
3. Select the [Profile Management] tab.
4. Click the [New] button. The Profile Management window will appear.

5. Enter the following information required to establish connection to the wireless LAN:

Profile Name

Enter a name for this configuration profile

Network names

Enter the appropriate SSID(s) of the wireless networks to which this device will connect. You have the option of entering up to three SSID's.

6. Select the [Advanced] tab.
7. Choose appropriate Power Save Mode setting. Options are [Off], [Normal], and [Maximum]. [Normal] is the default setting.
8. Choose the appropriate type of network connection. Options are [Access Point] (same as infrastructure mode) and [AdHoc].
9. Select the [Security] tab.
10. Select the appropriate security method for your wireless network.

WPA

Choose the appropriate WPA EAP type - PEAP or TLS. Please see your network administrator for the appropriate configuration settings.

WPA-PSK

Enter the appropriate pre-shared key. Please see your network administrator for the appropriate configuration settings.

802.1x

Choose the appropriate 802.1x/EAP type: TLS, PEAP, or LEAP. Please see your network administrator for the appropriate configuration settings.

Pre-Shared Key

Same as Network Key or WEP Key. Entry methods include hexadecimal or ASCII text. If you wish to use ASCII characters, enter the network key in a string consisting of five or thirteen characters. The characters that can be used for the Network Key are: 0 - 9, A - Z, a - z, and _.

If you wish to use a hexadecimal number, enter the network key in a string consisting of 10 to 26 characters. The characters that can be used for the network key are: 0 - 9, A - F, and a - f. For ad hoc connections, enter the same network key for all computers connected to the network. For access point (infrastructure) connection, enter the value

to match the access point. For information about the access point, refer to the access point manual.

CONNECTION TO THE NETWORK

If there is the administrator of the network, contact the network administrator for data settings prior to connecting to the network.

Setting the network

Perform the "Setting TCP/IP" and "Confirming the computer and work group names" operations for network connection.

Setting TCP/IP

POINT

To change the setting of the IP address, you need to be logged in from Windows as an administrator.

1. Click the [Start] -> [Settings] -> [Control Panel].
2. Double-click the [Network and Dial-up Connections] icon. The [Network and Dial-up Connection] window will be displayed.
3. Right-click [Local Area Connection], and click [Properties] in the menu displayed. The [Local Area Connection Properties] window will be displayed.
4. Click [Internet Protocol (TCP/IP)] and then click [Properties]. The [Properties] window will be displayed.
5. Set the IP address:
 - **For ad hoc connection**
Select [Use the following IP address:], then enter data in [IP address] and [Subnet mask]. See page 117 for IP address setting.
 - **For access point (infrastructure) connection**
Select [Obtain an IP address automatically] and [Obtain DNS server address automatically].

Follow directions from the network administrator about IP address settings, DNS server setting, and the default gateway.
6. Click the [OK] button. Processing will return to the [Properties] window.
7. Click the [OK] button. If a message is displayed that requests you to restart the personal computer, click [Yes] and then restart the computer.

Confirming the computer and workgroup names**POINT**

To modify the computer name and/or the workgroup name, you need to be logged in from Windows as an administrator.

1. Click [Start] -> [Settings] -> [Control Panel].
2. Double-click the [System] icon. The [System Properties] window will be displayed.
3. Click the [Network Identification] tab.
4. Confirm the settings of [Full computer name] and [Work group].
 - The setting of [Full computer name] denotes the name for identifying the computers on the network. Any name can be assigned. The computer name will be identified more easily if the model number, the user name, and other factors are already set.
 - [Workgroup] denotes the group name of the network.
5. To change the name, click [Properties], then proceed in accordance with the instruction messages displayed on the screen. Processing will return to the [System Properties] window.

For ad hoc connection:

Assign the same network name to all personal computers existing on the network.

For access point (infrastructure) connection:

Assign the name of the workgroup to be accessed.

6. Click the [OK] button. If a message is displayed that requests you to restart the personal computer, click [Yes].

Setting the sharing function

Set the sharing function to make file and/or printer sharing with other network-connected personal computers valid. The setting operation is not required unless the sharing function is to be used.

The folder and printer for which the sharing function has been set will be usable from any personal computer present on the network.

**POINT**

To share a file and/or the connected printer, you need to be logged in as an administrator.

Setting the Microsoft network-sharing service

1. Click [Start] -> [Settings] -> [Control Panel].
2. Double-click the [Network and Dial-up Connections] icon. The [Network and Dial-up Connections] window will be displayed.
3. Right-click [Local Area Connection], and click [Properties] in the menu displayed. The [Properties] window will be displayed.
4. If [File and Printer Sharing for Microsoft Networks] is displayed, proceed to step 5. If [File and Printer Sharing for Microsoft Networks] is not displayed, skip to step 6.
5. Make sure that the [File and Printer Sharing for Microsoft Networks] check box is checked, and then click the [OK] button. Skip to "Setting file-sharing function" on page 102.
6. Click [Install]. The [Select Network Component Type] window will be displayed.
7. Click [Service], and then click the [Add] button. The [Select Network Service] window will be displayed.
8. Click [File and Printer Sharing for Microsoft Networks] and then click the [OK] button. Processing will return to the [Wireless Network Connection Properties] window, and [File and Printer Sharing for Microsoft Networks] will be added to the list.
9. Click the [OK] button.

Setting the file-sharing function

The procedure for setting the file-sharing function is laid down below taking the "work" folder within drive C as an example.

1. Double-click [My Computer] on the Desktop, and then double-click [Local Disk (C:)].
2. Right-click the "work" folder (or whichever folder you wish to share), and click [Sharing...] in the menu displayed. The [Properties] window will be displayed.
3. Select the [Sharing] tab if it isn't already selected.
4. Select [Share this folder], then enter data as required:
 - "Share name"
Enter the name of the folder to be shared.
 - "Comment"
Enter explanatory statements or notes about the folder to be shared.

- **“User limit”**
Enter the number of users who share the folder.
 - **[Permissions]**
Click the [Permissions] button to set permission levels for access to the folder.
 - **[Caching]**
Click the [Caching] button to configure settings for the off-line access to the folder.
5. Click the [OK] button. The folder will be set as a sharable folder, and the display of the icon for the “work” folder will change.

Setting the printer-sharing function

1. Click [Start] -> [Settings] -> [Printers]. A list of connected printers will be displayed.
2. Right-click the printer for which the sharing function is to be set, and then click [Sharing...] in the menu displayed. The property window corresponding to the selected printer will be displayed.
3. Click the Sharing tab if it is not already selected.
4. Check the [Shared as] checkbox and confirm the name of the printer to be shared or enter a new name. Click [OK]. Printer sharing will be set and the display of the icon for the printer will change.

Confirming connection

After you have finished the network setup operations, access the folder whose sharing has been set, and confirm the status of the radio in case of trouble such as a network connection failure.

In the case of an access point (infrastructure) connection, enter the necessary data for the access point before confirming connection. Refer to the manual of the access point for the access point setup procedure

Connecting your personal computer to another personal computer

1. Double-click [My Network Places] on the Desktop. The [My Network Places] window will be displayed.
2. Double-click the [Computers Near Me] icon. The personal computers connected to the network will be listed.
3. Double-click the name of the personal computer to which you wish to connect your own personal computer. The folder that specified in “Setting the file-sharing function” on page 102 will be displayed.
4. Double-click the folder to be accessed. The contents of the folder will be displayed.

Confirming the status of the radio waves

Intel PROSet Wireless LAN:

1. Click [Start] -> [Programs] -> [Intel Network Adapters] -> [Intel(R) PROSet]. The [Intel(R) PROSet] window will be displayed. (You can also double-click on the Intel PROSet icon in the system tray at the bottom right of the screen to open the window.)
2. Click the [General] tab and confirm radio status in the window displayed. The current connection status will be displayed.

- **Signal Quality**
The quality of the signals is displayed on a graph.
- **Network name (SSID)**
The connected network name (SSID) is displayed.
- **Profile name**
Profile name you set is displayed.
- **Mode**
If access point (infrastructure) connection is in use, “Access Point (AP)” will be displayed. If ad hoc connection is in use, “Ad hoc (Peer-to-peer)” will be displayed.
- **Security**
The setting status of WEP is displayed.
- **Speed**
The communications speed is displayed.
- **Band (Frequency)**
The current operating frequency band is displayed. When communication is possible, “802.11b (2.4 GHz)” is displayed.
- **Channel**
The channel number currently being used for the communications is displayed.

If connection cannot be made to the network or if you want to check for normal connection, see “Troubleshooting” on page 112.

Atheros Wireless LAN:

1. Right-click the Atheros icon in the lower right corner of the screen.
2. Click [Open Utility]. The Atheros Wireless Configuration Utility window opens.
3. Select the Link Status tab. The current radio condition is displayed. (When the radio is turned off or the computer is not yet connected, some of the conditions are not displayed.)

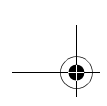

LifeBook S6000 Notebook

- **Status**
The connection condition is shown.
- **Network Name (SSID)**
The connected network name (SSID) is displayed.
- **AP's MAC Address**
In access point (infrastructure) mode, the MAC address of the access point currently in connection is shown. In Ad Hoc mode, a value is shown, but it is not the MAC address of the connected client.
- **WEP**
When the Network key is used, this appears as [Enabled]. Otherwise, [Disabled] appears.
- **Speed**
The current communications speed is displayed in Mbps.
- **Channel**
The channel number currently being used for the communications is displayed.
- **Client IP Address**
The IP address is shown.
- **Network Connection Type**
[Access Point] or [Ad Hoc] is displayed.
- **Radio State**
When radio waves are being transmitted, [Enabled] appears.
- **Signal**
The longer the bar graph, the better the radio wave signal.
- **Noise**
The shorter the bar graph, the less noise, resulting in a better the radio wave signal.

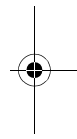
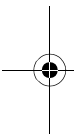

Other settings

SETTING OF POWER-SAVING FUNCTION

You can set the power-saving function of wireless LAN. Default setting is auto-setting. In case of using the power-saving function, manually control the communication performance.

Intel PROSet Wireless LAN:

1. Click [Start] -> [(All) Programs] -> [Intel Network Adapters] -> [Intel(R) PROSet]. The Intel(R) PROSet window will be displayed.
2. Click the [Adapter] tab.
3. Click the [Configure] button in [Power settings]. The [Power settings] window will be displayed.
4. Select [Manual], and adjust the bar to set the power-saving function.

Setting of transmission power during ad hoc connection

By controlling the transmission power during ad hoc connection, you can broaden or narrow the communication range. This setting is only effective during ad hoc connection. It will be ineffective during access point connection.

Intel PROSet Wireless LAN:

1. Click [Start] -> [(All) Programs] -> [Intel Network Adapters] -> [Intel(R) PROSet]. The Intel(R) PROSet window will be displayed.
2. Click the [Adapter] tab.
3. Click the [Configure] button in [Power settings]. The [Power settings] window will be displayed.
4. Adjust the "Transmission Power (Ad Hoc)" bar to set the transmission power.

Setting of channels during ad hoc connection

You can set channels during ad hoc connection. Channel 11 is set by default. When connecting to an existing ad hoc network, no channel setting will be effective.

This setting is only effective during ad hoc connection; it will be ineffective during access point connection.

POINT

When changing channels during ad hoc connection, change the channel settings of all connected computers with the same Network name (SSID) at the same time. After changing the channels, turn off all computers and -- after they are all turned off -- turn them back on.

Intel PROSet Wireless LAN:

1. Click [Start] -> [(All) Programs] -> [Intel Network Adapters] -> [Intel(R) PROSet]. The Intel(R) PROSet window will be displayed.
2. Click the [Adapter] tab.
3. Click the [Configure] button in [Ad hoc settings]. The [Ad hoc settings] window will be displayed.
4. Change channels during ad hoc connection by selecting a new channel from the drop down list.
5. Click [OK].

Atheros Wireless LAN:

1. Click on the My Computer icon. Select [View system information] from the left frame.
2. Select the Hardware tab and click [Device Manager].
3. Double-click "Atheros BCM4306 Wireless LAN Adapter" under [Network Adapters].
4. In the Atheros BCM4306 Wireless LAN Adapter window, select the Advanced tab.
5. Select IBSS Channel Number from the list, and change the value from the [Value:] dropdown list to the desired channel.
6. Click [OK].

Troubleshooting

Causes and countermeasures for troubles you may encounter while using your wireless LAN are described in the following table.

Problem	Possible Cause	Possible Solution
Unavailable network connection	Incorrect network name (SSID) or network key	<p>Ad hoc connection: verify that the network names (SSID's) and network keys (WEP) of all computers to be connected have been configured correctly. SSID's and WEP key values must be identical on each machine.</p> <p>Access Point (Infrastructure) connection: set the network name (SSID) and network key to the same values as those of the access point.</p> <p>Set the Network Authentication value identically to that of the Access Point. Please consult your network administrator for this value, if necessary.</p> <p>For the method of setting network authentication, refer to the following pages:· Windows XP: "Assigning parameters" on page 99· Windows 2000: "Assigning parameters" on page 105</p>
	Poor radio wave condition	<p>Ad hoc connection: Retry connection after shortening the distance to the destination computer or removing any obstacles for better sight.</p> <p>Access Point (Infrastructure) connection: Retry connection after shortening the distance to the access point or removing any obstacles for better sight.</p> <p>To check the wave condition, refer to the following pages:· Windows XP: "Confirming the status of the radio waves" on page 103· Windows 2000: "Confirming the status of the radio waves" on page 109</p>
	Radio wave transmission has stopped	Check if the wireless switch is turned ON. Also verify "Disable Radio" is not checked in "Network setting" window. Refer to "Starting Transmission" on page 98.
	The computer to be connected is turned off	Check if the computer to be connected is turned ON.
	Active channel duplication due to multiple wireless LAN networks	If there is any other wireless LAN network nearby, change channels to avoid active channel duplication. For the method of checking active channels, refer to the following pages:· Windows XP: "Confirming the status of the radio waves" on page 103· Windows 2000: "Confirming the status of the radio waves" on page 109
	No right of access to the network to be connected	Check if you have a right of access to the network to be connected with.
	Incorrectly-performed network setting	Check the protocol, work group name or shared setting. For the method of checking, refer to the following pages:· Windows XP: "Connection to the Network" on page 101· Windows 2000: "Connection to the Network" on page 107
	Unmatched [Network authentication (shared mode)] settings in Windows XP	If the setting of [Network authentication (shared mode)] is not matched with that of access point or computer to be connected with, no communication can be established. Check the parameter setting. Refer to "Assigning parameters" on page 99.

Wireless LAN User's Guide

Problem	Possible Cause	Possible Solution
Unavailable network connection (continued)	It takes too long to retrieve the network and display the connected computers.	Retrieve computers as follow: Windows XP: 1. Click [Start] button, then click [Search]. 2. Click [Computers or people]. 3. Click [Computers on the network]. 4. Input the name of computer to be connected with in [Computer name] and click [Search]. 5. Double-click the icon of connected computer. Windows 2000: 1. Click [Start] -> [Find] -> [Files and folders]. 2. Click [Computer] in [Find other items]. 3. Input the name of computer to be connected with in [Computer name] and click [OK]. 4. Double-click the icon of connected computer.
	Incorrect setting of IP address	Check the network setting. Windows XP: "Setting the network" on page 101. Windows 2000: "Setting the network" on page 107 In case of using TCP/IP protocol, you can check IP address as follows: 1. Windows XP: Click [Start] -> [All programs] -> [Accessories] -> [Command prompt]. Windows 2000: Click [Start] button -> [Program] -> [Accessories] -> [Command prompt]. 2. In [Command prompt] or [MS-DOS prompt] window, input [IPCONFIG] command as follows, then press [Enter] key. Example: In case of C drive being the hard disk: C:\ipconfig [Enter] Check that the IP address is correctly displayed: IP Address.....: 10.0.1.3 Subnet Mask.....: 255.255.255.0 Default Gateway.....: 10.0.1.1 When IP address is displayed as [169.254.XXX.YYY] or [0.0.0.0], IP address is not correctly fetched from the access point. In that case, restart the computer itself. If the display is still unchanged, check the setting of TCP/IP. If [Cable Disconnected] or [Media Disconnected] is displayed without showing IP address, check the setting of network name (SSID) and network key. Also, set the network authentication according to the access point.



LifeBook S6000 Notebook

Problem	Possible Cause	Possible Solution
Communication is disconnected soon after connection to the access point	Access control may be disabled	<p>In case of Windows XP, check the setting of "Enable network access control using IEEE 802.1X". Refer to "Assigning parameters" on page 99.</p> <p>When restricting the access of wireless LAN clients using IEEE802.1X authentication, put a check mark on "Enable network access control using IEEE 802.1X".</p> <p>When using at home, remove a check mark on "Enable network access control using IEEE802.1X".</p> <p>For the method of setting related with IEEE802.1X authentication, refer to the access point manual.</p>

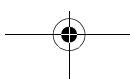
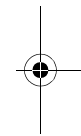
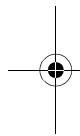

Wireless LAN Glossary

Ad hoc

A designation for wireless LAN network configuration. It indicates a form of communication limited to those personal computers which have wireless LAN function. For details, refer to "Ad hoc connection" on page 96.

Channel

The frequency band of wireless LAN to be used in communications over wireless LAN or at the access point.

DHCP (Dynamic Host Configuration Protocol)

A protocol used for automatically fetching communication parameters such as IP addresses. The side which assigns IP address is called DHCP server and the side that is assigned it is called DHCP client.

DNS (Domain Name System)

A function that controls the correspondence of IP addresses assigned to a computer with the name. Even for those computers whose IP addresses are unknown, if their names are known, it is possible to communicate with them.

IEEE802.11a

One of the wireless LAN standards prescribed by the 802 committee in charge of establishing standards of LAN technology in IEEE (Institute of Electrical and Electronic Engineers). It allows communications at the maximum speed of 54 Mbps by using a 5GHz band which can freely be used without radio communication license.

IEEE802.11b

One of the wireless LAN standards prescribed by 802 committee in charge of establishing standards of LAN technology in IEEE (Institute of Electrical and Electronic Engineers). It allows communications at the maximum speed of 11Mbps by a band of 2.4 GHz (ISM band) which can freely be used without radio communication license.

Access point

A designation of Wireless LAN network configurations. It indicates a form of communication using an Access Point. For details, refer to "access point connection" on page 96.

IP address

An address used by computers for communicating in TCP/IP environment. IP addresses have global and private addresses. A global address is a unique address in

the world. A private address is a unique address within a closed network.

LAN (Local Area Network)

An environment connecting computers within a relatively small range, such as the same floor and building.

MAC address (Media Access Control Address)

A physical address inherent to a network card. For Ethernet, the top three bytes are controlled/assigned as a vendor code. The remaining three bytes comprise the code uniquely (to avoid duplication) controlled by each vendor. As a result, there is no Ethernet card with the same physical address in the world. In Ethernet, the frame transmission/reception is performed based on this address.

MTU (Maximum Transmission Unit)

The maximum size of data which can be transmitted at one time in networks including the Internet. In an environment whose maximum size of data is too large to correctly receive data, normal communications can be restored by setting the size of MTU to a smaller value.

Network authentication

The method of authentication performed by wireless LAN clients to connect with the access point. There are two types: open system authentication and shared key authentication. The type of authentication must be set to each client and also coincide with the setting of access point with which to communicate. Network authentication is sometimes called authentication mode.

Network key

Data that is used for encrypting data in data communication. The personal computer uses the same network key both for data encryption and decryption, therefore, it is necessary to set the same network key as the other side of communication.

Network name (SSID: Security Set Identifier)

When a wireless LAN network is configured, grouping is performed to avoid interference or data theft. This grouping is performed with "Network name (SSID)". In order to improve security, the network key is set allowing no communication unless "Network name (SSID)" coincides with the network key.

Open system authentication

One of network authentication types for wireless LAN. Since there is no check of network key upon authentication, clients can connect to the access point without



submitting correct network keys. However, in case of actual communications, the same network key must be set. Open system authentication is sometimes called Open key authentication.

PPPoE (Point to Point Protocol over Ethernet)

A method of allowing the authentication protocol adopted in telephone line connection (PPP) to be used over an Ethernet.

Protocol

A procedure or rule of delivering data among computers. Ordered data communication is allowed by making all conditions required for communication including the method of data transmission/reception and actions upon communication errors into procedures.

Shared key authentication

One of the network authentication types for wireless LAN. Upon authentication, the access point checks whether the same network key is set to the client. If the client uses a wrong network key or the network key itself is not set, authentication is unsuccessful, allowing no communications with the access point.

SSID (Security Set Identifier)

See "Network name"

Subnet mask

TCP-IP network is controlled by being divided into multiple smaller networks (subnets). IP address consists of the subnet address and the address of each computer. Subnet mask defines how many bits of IP address comprise the subnet address. The same value shall be set among computers communicating with each other.

TCP/IP (Transmission Control Protocol/Internet Protocol)

A standard protocol of the Internet.

Wi-Fi

Indicates that the interconnectivity test of the organization which guarantees the compatible connection of wireless LAN (Wi-Fi Alliance) has been passed.

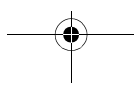

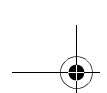

IP address information



POINT

IP addressing is much more complicated than can be briefly explained in this document. You are advised to consult with your network administrator for additional information.

If IP address is unknown, set IP address as follows:

If you have an access point (DHCP server) on the network, set the IP address as follows:

Windows 2000: [Obtain an IP address automatically]

Windows XP: [Obtain an IP address automatically]



POINT

A DHCP server is a server that automatically assigns IP addresses to computers or other devices in the network. There is no DHCP server for the AdHoc network.

If the IP address is already assigned to the computer in the network, ask the network administrator to check the IP address to be set for the computer.

If no access point is found in the network:

An IP address is expressed with four values in the range between 1 and 255.

Set the each computer as follows: The value in parentheses is a subnet mask.

<Example>

Computer A: 192.168.100.2 (255.255.255.0)

Computer B: 192.168.100.3 (255.255.255.0)

Computer C: 192.168.100.4 (255.255.255.0)

:

:

Computer X: 192.168.100.254 (255.255.255.0)

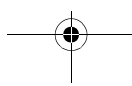

LifeBook S6000 Notebook

Specifications

Item	Specification
Type of network	Conforms to IEEE 802.11b/802.11g (Wi-Fi based)*
Transfer rate	(Automatic switching) Intel PROSet WLAN: 11 Mbps maximum data rate Atheros WLAN: 54 Mbps maximum data rate
Active frequency	2400~2473MHz
Number of channels	11 channels, 3 non-overlapping channels
Security	Network name (SSID) Network key (64 bits/128 bits)** Intel PROSet WLAN: WPA 1.0 compliant and CCX certified Atheros WLAN: WPA 1.0 compliant
Maximum recommended number of computers to be connected over wireless LAN (during ad hoc connection)	10 units or less ***

* "Wi-Fi based" indicates that the interconnectivity test of the organization which guarantees the interconnectivity of wireless LAN (Wi-Fi Alliance) has been passed.

** Encryption with network key (WEP) is performed using the above number of bits, however, users can set 40 bits/104 bits after subtracting the fixed length of 24 bits.

*** Depending on practical environments, the allowable number of computers to be connected may be decreased.

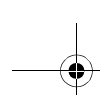

Index

A

About This Guide	1
AC	
adapter	27
indicator	11
plug adapters	71
ACPI	83
Active-Matrix Display	83
Anti-theft lock slot	8
Application Panel	20
Auto/Airline Adapter	27, 83

B

Battery	37
alarm	37
bay	10
care	72
charging indicator	12
cold-swapping	38
conserving power	32
dead	60
faulty	60
increasing life	72
level indicators	11
lithium ion battery	37, 85
low	37
problems	60
recharging	37
replacing	38
shorted	38
suspend mode	37
BIOS	83
guide	29
setup utility	29
Boot	83
Boot Sequence	29
Built-in Speakers	56

C

Cache Memory	83
CapsLock	12
CardBus	83
CD-ROM	39, 83
problems	56

Centrino	78
Clicking	15
CMOS RAM	83
Cold-swap	19
Cold-swapping	38
COMM Port	83
Configuration Label	10, 77
Control	40
Controls and Connectors	6
Conventions Used in the Guide	1
CRT	84
Cursor	15
Cursor Keys	14

D

DC Output Cable	27
DC Power Jack	9, 27
Default Value	84
Device Ports	49, 78
DIMM	45, 84
Disk	
care	72
Display Panel	6, 28
adjusting	28
brightness	28
closing	28
latch	6
opening	28
power management	28
problems	61, 62
Display Timeout	33
DMA	84
DMI	84
Docking Port	50
Dolby Headphone	41
Double-Clicking	15
Dragging	16
Drive Image Special Edition (DISE)	66
Drivers and Application CD	67
DVD	39

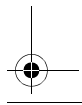
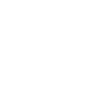
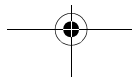
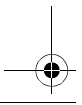
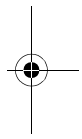
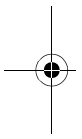

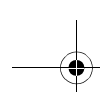

DVD drive
 access indicator 12
 tray release 65
 DVD/CD-RW combo 39
 DVD/CD-RW/CD-ROM
 access indicator 12
 DVD/CD-RW/CD-ROM drive
 problems 56

E

ECP 84
 Emergency tray release 8
 Error Messages 64
 Extended Memory 85
 External Floppy Disk Drive
 problems 57
 External Monitor Port 9, 51

F

Flexible Bay 8, 18
 cold-swapping 19
 devices 18
 eject lever 8
 installing 18
 removing 18
 Floppy Disk
 ejecting 42
 formatting 42
 initializing 42
 loading 42
 preparing 42
 write protect 42
 Fujitsu Contact Information 1
 Fujitsu LifeBook
 storing 71
 traveling 71
 Function Key
 F10 14
 F3 14
 F4 14
 F6 14
 F7 14
 F8 14, 17
 F9 14, 17
 FN 14

H

Hard Disk Drive
 access indicator 12
 problems 57
 Hard Disk Timeout 33
 Headphone Jack 7, 51
 Hibernation Feature 32
 disable/enable 32

I

IDE 85
 Infrared Port 9, 50
 Internal LAN Jack 49
 IrDA 50, 85
 IRQ 85

K

Keyboard 6, 13
 cursor keys 13
 function keys 13
 numeric keypad 13
 problems 57
 windows keys 13

L

LAN (RJ-45) Jack 9
 LifeBook Security Application Panel
 buttons 22
 configuring 22
 deactivating 23
 deactivating and activating 23
 launching applications 22
 operating 21
 passwords 20
 uninstalling 21
 LifeBook Security/Application Panel 6

M

Media Player
 care 73
 Control Panel 40
 loading 39
 removing 40
 Software 39, 40
 using 41

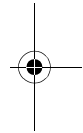
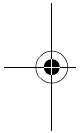

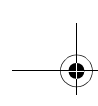
**Index**

Media player		POST	.86
care	73	Power	
Media Player Drive	39	AC adapter	.27
Memory		Auto/Airline adapter	.27
capacity	46	failure	.59
compartment	10, 45	indicator	.11
installing	45	management	.32
problems	58	off	.33
removing	45, 46	on	.29
upgrade module	45	problems	.61
Microphone Jack	7, 51	sources	.27
MIDI	86	Power Management	.32, 33
Modem	9	Power On Self Test	.29, 64
problems	58	Power/Suspend/Resume Button	.6, 32
Modem Jack	49	Pre-Installed Software	.79
Modem Result Codes	65	Adobe Acrobat Reader	.80
Modular Devices	18	BatteryAid	.80
installing	18	Drive Image Special Edition (DISE)	.80
removing	18	Fujitsu HotKey	.80
Mouse		Intel SpeedStep	.80
problems	57	LifeBook Application Panel	.80
MPU-401	86	manuals	.80
N		Netscape 6.01	.80
NTSC	86	Quicken New User Edition	.80
Numeric Keypad	13	Preparation for wireless LAN connection (XP)	.99
NumLk	12	PS/2 Port	.50
P		R	
Parallel Port	49, 86	Registration	.30, 31
problems	58	Restarting	.33
PC Card		Restoring Your Pre-installed Software	.66
access indicator	12	RJ-11	.49
care	73	RJ-45	.49
installing	43	S	
problems	59	ScrLk	.12
removing	43	SDRAM	.10, 45
slot	7	Security Indicator	.12
PCMCIA	86	Security Panel	.20
Pointing Device		Serial Port	.50, 87
See Touchpad	15	problems	.58
Port Replicator	47	SMART	.87
attaching	48	Specifications	.77
back panel components	47	Audio	.77
connector	10	Chipset	.77
detaching	48	Dimensions and Weight	.79
front panel components	48	Environmental Requirements	.79
problems	57	Keyboard	.78



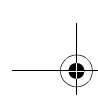

LifeBook S6000 Notebook

T

Touchpad 15
 buttons 15
 controls 16

Touchpad Pointing Device 6

Troubleshooting 55

U

Universal Serial Bus Ports 50

Unpacking 5

USB 50, 58
 problems 58

USB 2.0 Ports 9

V

Volume control 17

W

Warranty1

WFM88

Windows

Windows 2000 Professional1
 Windows XP Home1
 Windows XP Professional1

Windows keys13
 Application key13
 Start keys13

Wireless LAN

Ad Hoc Mode96
 Before Using the Wireless LAN96
 Broadcom Wireless LAN96
 Connection to the network (Windows 2000) ...107
 Connection using Windows 2000105
 Connection using Windows XP99
 For better communications97
 Infrastructure Mode96
 Intel PROSet Wireless LAN96
 IP address information117
 Other settings111
 Preparation for wireless LAN connection
 (Windows 2000)105
 Setting of power-saving function111
 Specifications118
 Starting Transmission98
 Stopping transmission98
 Troubleshooting112
 Wireless LAN Glossary115

Wireless LAN Switch9

