

HP Photosmart D7100 series

User Guide

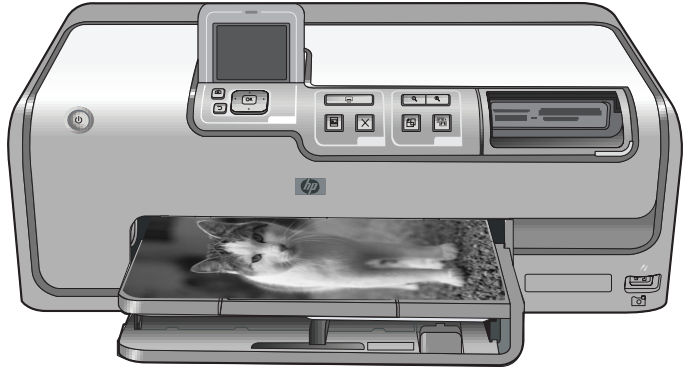



www.hp.com/support

021 672 280	الجزائر
Argentina (Buenos Aires)	54-11-4708-1600
Argentina	0-800-555-5000
Australia	1300 721 147
Australia (out-of-warranty)	1902 910 910
Österreich	www.hp.com/support
17212049	البحرين
België	www.hp.com/support
Belgique	www.hp.com/support
Brasil (Sao Paulo)	55-11-4004-7751
Brasil	0-800-709-7751
Canada (Mississauga Area)	(905) 206-4663
Canada	1-800-474-6836
Central America & The Caribbean	www.hp.com/support
Chile	800-360-999
	10-68687980
中国	8008103888
Colombia (Bogotá)	571-606-9191
Colombia	01-8000-51-4746-8368
Costa Rica	0-800-011-1046
Česká republika	810 222 222
Danmark	www.hp.com/support
Ecuador (Andinatel)	1-999-119 800-711-2884
Ecuador (Pacifitel)	1-800-225-528 800-711-2884
(02) 6910602	مصر
El Salvador	800-6160
España	www.hp.com/support
France	www.hp.com/support
Deutschland	www.hp.com/support
Ελλάδα (από το εξωτερικό)	+ 30 210 6073603
Ελλάδα (εντός Ελλάδας)	801 11 75400
Ελλάδα (από Κύπρο)	800 9 2654
Guatemala	1-800-711-2884
香港特別行政區	2802 4098
Magyarország	06 40 200 629
India	1-600-425-7737 91-80-28526900
Indonesia	+62 (21) 350 3408
+971 4 224 9189	العراق
+971 4 224 9189	الكويت
+971 4 224 9189	لبنان
+971 4 224 9189	قطر
+971 4 224 9189	اليمن
Ireland	www.hp.com/support
1-700-503-048	ישראל
Italia	www.hp.com/support
Jamaica	1-800-711-2884

日本	0570-000511
日本 (携帯電話の場合)	03-3335-9800
0800 222 47	الأردن
한국	1588-3003
Luxembourg	www.hp.com/support
Malaysia	1800 888588
Mauritius	(262) 262 210 404
México (Ciudad de México)	55-5258-9922
México	01-800-472-68368
081 005 010	المغرب
Nederland	www.hp.com/support
New Zealand	0800 441 147
Nigeria	1 3204 999
Norge	www.hp.com/support
24791773	عُمان
Panamá	1-800-711-2884
Paraguay	009 800 54 1 0006
Perú	0-800-10111
Philippines	2 867 3551
Polska	22 5666 000
Portugal	www.hp.com/support
Puerto Rico	1-877-232-0589
República Dominicana	1-800-711-2884
Reunion	0820 890 323
România	0801 033 390
Россия (Москва)	095 777 3284
Россия (Санкт-Петербург)	812 332 4240
800 897 1415	السعودية
Singapore	6 272 5300
Slovensko	0850 111 256
South Africa (international)	+ 27 11 2589301
South Africa (RSA)	086 0001030
Rest of West Africa	+ 351 213 17 63 80
Suomi	www.hp.com/support
Sverige	www.hp.com/support
Switzerland	www.hp.com/support
臺灣	02- 8722 8000 0800 010 055
ໄທ	+66 (2) 353 9000
071 891 391	تونس
Trinidad & Tobago	1-800-711-2884
Türkiye	+90 (212)291 38 65
Україна	(044) 230-51-06
600 54 47 47	الإمارات العربية المتحدة
United Kingdom	www.hp.com/support
United States	1-(800)-474-6836 (1-800 hp invent)
Uruguay	0004-054-177
Venezuela (Caracas)	58-212-278-8666
Venezuela	0-800-474-68368
Việt Nam	+84 88234530

Copyrights and trademarks

© 2006 Hewlett-Packard Development Company, L.P.

The information contained herein is subject to change without notice. Reproduction, adaptation, or translation without prior written permission is prohibited, except as allowed under the copyright laws.

Hewlett-Packard Company notices

The information contained in this document is subject to change without notice.

All rights reserved. Reproduction, adaptation, or translation of this material is prohibited without prior written permission of Hewlett-Packard, except as allowed under copyright laws.

The only warranties for HP products and services are set forth in the express warranty statements accompanying such products and services. Nothing herein should be construed as constituting an additional warranty. HP shall not be liable for technical or editorial errors or omissions contained herein.

Trademarks

HP, the HP logo, and Photosmart are property of Hewlett-Packard Development Company, L.P.

The Secure Digital logo is a trademark of the SD Association.

Microsoft and Windows are registered trademarks of Microsoft Corporation.

CompactFlash, CF, and the CF logo are trademarks of the CompactFlash Association (CFA).

Memory Stick, Memory Stick Duo, Memory Stick PRO, and Memory Stick PRO Duo are trademarks or registered trademarks of Sony Corporation.

MultiMediaCard is a trademark of Infineon Technologies AG of Germany, and is licensed to the MMCA (MultiMediaCard Association).

Microdrive is a trademark of Hitachi Global Storage Technologies.

xD-Picture Card is a trademark of Fuji Photo Film Co., Ltd., Toshiba Corporation, and Olympus Optical Co., Ltd.

Mac, the Mac logo, and Macintosh are registered trademarks of Apple Computer, Inc.

iPod is a trademark of Apple Computer, Inc.

Bluetooth is a trademark owned by its proprietor and used by Hewlett-Packard Company under license.

PictBridge and the PictBridge logo are trademarks of the Camera & Imaging Products Association (CIPA).

Other brands and their products are trademarks or registered trademarks of their respective holders.

Regulatory model identification number

For regulatory identification purposes, your product is assigned a Regulatory Model Number. The Regulatory Model Number for your product is VCVRA-0603. This regulatory number should not be confused with the marketing name (HP Photosmart D7100 series, etc.) or product numbers (Q7046A, etc.).

Energy consumption - Energy Star®

Hewlett-Packard Company is committed to providing quality products in an environmentally sound manner. For information about the HP's environmental product stewardship program see the onscreen help.

Contents

1	Welcome	5
	Special features.....	5
	Accessing the onscreen HP Photosmart help.....	5
	Printer parts.....	6
	Optional accessories.....	9
	Printer menu.....	9
	View & Print.....	10
	Save.....	10
	Share.....	10
	Settings.....	10
2	Get ready to print	13
	Load paper.....	13
	Choose the right paper.....	13
	Paper loading tips.....	13
	Load the main tray.....	13
	Load the photo tray.....	14
	Insert ink cartridges.....	15
	Purchasing replacement ink cartridges.....	15
	Ink cartridge tips.....	16
	Ink cartridge warranty information.....	16
	Inserting or replacing the ink cartridges.....	17
	Insert memory cards.....	18
	Supported file formats.....	18
	Inserting a memory card.....	19
	Memory card types.....	19
	Removing a memory card.....	20
3	Printing photos without a computer	21
	Printing photos.....	21
	Print photos from a memory card.....	21
	Print one or more photos.....	21
	Print all photos on the memory card.....	21
	Print camera-selected photos from a memory card.....	22
	Print using the Wizard.....	22
	Print photos from video clips.....	22
	Print a photo index.....	23
	Stop printing.....	23
	Print photos from a digital camera.....	23
	Digital camera with Bluetooth wireless technology.....	23
	Digital camera with PictBridge technology.....	24
	Print photos from an iPod.....	24
	Photo layouts.....	24
	Improving photo quality.....	26
	Adjust photos with poor brightness.....	26
	Remove red eye from photos.....	26
	Adjust poor-quality video clips.....	27

Getting creative.....	27
Add a color effect.....	27
Add the date and time to your prints.....	27
Change the print quality.....	27
Crop a photo.....	28
Print panoramic photos.....	28
4 Getting connected.....	29
Connecting to other devices.....	29
Saving photos to a computer.....	31
Connecting through HP Photosmart Share.....	31
5 Printing from a computer.....	33
Using creative options in the printer software.....	33
HP Photosmart Premier (Windows users).....	33
HP Photosmart Essential (Windows users).....	33
HP Photosmart Studio (Macintosh Users).....	34
HP Photosmart Share.....	34
Set print preferences.....	34
Open the electronic help.....	35
HP Real Life technologies features.....	35
6 Care and maintenance.....	37
Clean and maintain the printer.....	37
Clean the outside of the printer.....	37
Aligning the printer.....	37
Print a sample page.....	37
Automatically clean the printhead.....	38
Manually clean the ink cartridge contacts.....	38
Print a self test report.....	39
Update the software.....	40
Store and transport the printer and ink cartridges.....	41
Store and transport the printer.....	41
Store and transport the ink cartridges.....	41
Maintain the quality of photo paper.....	41
7 Troubleshooting.....	43
Printer hardware problems.....	43
Printing problems.....	44
Error messages.....	48
Paper errors.....	48
Ink cartridge errors.....	50
Memory card errors.....	53
Computer and connectivity printing errors.....	56
8 HP support.....	57
Support process.....	57
HP support by phone.....	57
Phone support period.....	57
Placing a call.....	57
After the phone support period.....	58
A Specifications.....	59
System requirements.....	59
Printer specifications.....	59
B HP Warranty.....	63

Index.....65

1 Welcome

Thank you for purchasing an HP Photosmart D7100 series printer! With this new photo printer you can print beautiful photos, save photos to a computer, and create fun and easy projects with or without a computer.

This guide primarily explains how to print without connecting a computer. To learn how to print from a computer, install the printer software and view the electronic Help. For an overview of using a computer and the printer together, see [Printing from a computer](#). For information about installing the software, see the *Quick Start* guide.

Home users can learn how to:

- Print borderless photos from the printer or from a computer
- Choose a photo layout
- Convert a color photo to black and white, or apply a color effect such as Sepia or Antique

The printer comes with the following documentation:

- **Quick Start Guide:** The *Quick Start Guide* explains how to set up the printer, install the printer software, and print your first photo.
- **User Guide:** The *User Guide* is the book you are reading. This guide describes the basic features of the printer, explains how to use the printer without connecting a computer, and contains hardware troubleshooting information.
- **Onscreen help:** The onscreen HP Photosmart help describes how to use the printer with a computer and contains software troubleshooting information.

Special features

New features and media make it easier than ever to produce high-quality photos:

- When you use the new HP Advanced Photo Paper (also called HP Photo Paper in some countries/regions), special sensors in the printer detect a mark on the back of the paper and automatically select the optimal print settings. For more information about this new paper, see [Choose the right paper](#).
- HP Real Life technologies make it easy for you to get better photos. Automatic red eye removal and adaptive lighting to enhance detail in shadows are just a few of the many technologies included. You can explore the many editing and enhancing options from both the control panel and from the printer software. To access these features from the control panel, see [Improving photo quality](#). To learn how to find them in the software, see [HP Real Life technologies features](#).

Accessing the onscreen HP Photosmart help

After you have installed the HP Photosmart software on a computer, you can view the onscreen HP Photosmart help:

- **Windows PC:** From the **Start** menu, select **Programs** (in Windows XP, select **All Programs**) > **HP** > **HP Photosmart D7100 series** > **Photosmart Help**.
- **Macintosh:** From the Finder **Help** menu, choose **Mac Help**. From the Help Viewer **Library** menu, choose **HP Photosmart Mac Help**.

Printer parts

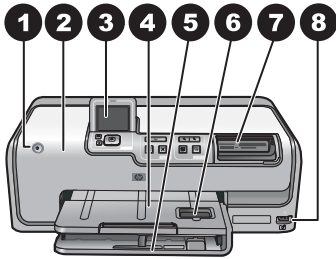

Front of printer

1	On: Press this button to turn on the printer.
2	Top cover: Lift this cover to access the ink cartridges and to clear paper jams. To lift the cover, grasp the top cover below the HP logo and pull upward.
3	Printer Screen: Use this screen to view photos, menus, and messages.
4	Output tray: Use this tray to catch your printouts. Lift this tray to access the photo tray.
5	Main tray: Pull out this tray and load paper, transparencies, envelopes, or other media with the side to be printed facing down.
6	Photo tray: Lift the output tray, pull out this tray, and load small-size paper up to 10 x 15 cm (4 x 6 inch) into the photo tray for printing with the side to be printed facing down. The paper may be tabbed or untabbed.
7	Memory card slots: Insert memory cards here. For a list of supported memory cards, see Insert memory cards .
8	Camera port: Connect a PictBridge™ digital camera, the optional HP Bluetooth® wireless printer adapter, or an iPod.

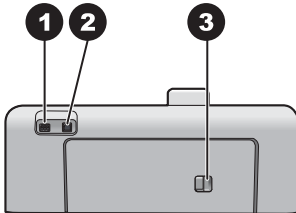

Back of printer

1	Power cord connection: Use this port to connect the power cord included with the printer.
2	USB port: Use this port to connect the printer to a computer.
3	Rear access door: Remove this door to clear paper jams or to install the optional HP Automatic Two-sided Printing Accessory. See Optional accessories .

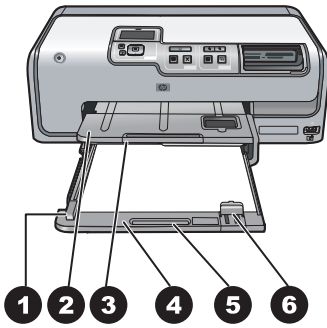

Main and Output trays

1	Paper-width guide: Adjust this guide to fit close to the edge of the paper in the main tray.
2	Output tray: Use this tray to catch your printouts. Lift this tray to access the photo tray.
3	Output tray extender: Pull towards you to extend the output tray to catch your printouts.
4	Main tray: Pull out this tray and load plain paper, transparencies, envelopes, or other media with the side to be printed facing down.
5	Main tray grip: Pull toward you to extend the Main tray.
6	Paper-length guide: Adjust this guide to fit close to the end of the paper in the main tray.

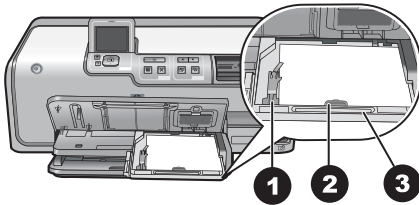
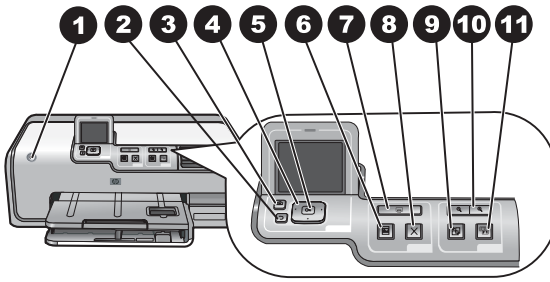

Photo tray

1	Paper-width guide: Adjust this guide to fit close to the edge of the paper in the photo tray.
2	Paper-length guide: Adjust this guide to fit close to the end of the paper in the photo tray.
3	Photo tray grip: Pull toward you to extend the photo tray.



Control panel

1	On: Turn on the printer or put it into power save mode.
2	Back: Step back one screen at a time.
3	Home: Press to return to the home screen.
4	Navigation arrows: Adjust the crop box, navigate menu choices, and control the playback of a video clip.
5	OK: Select a highlighted item, menu or dialog choice, and play/pause a video clip during playback.
6	Print Preview: View a preview of the selected photo or photos.
7	Print: Print the selected photos from the inserted memory card, or from a camera connected to the front camera port.
8	Cancel: Stops a print job.
9	Rotate: Rotate a photo or a crop box.
10	Zoom (+)(-): Zoom in or out of a photo or crop box. You can also press Zoom (-) to view photos four at a time when viewing a photo at normal magnification.
11	Photo Fix: Automatically enhances and applies lighting, contrast, focus and red eye removal features to all printed photos.

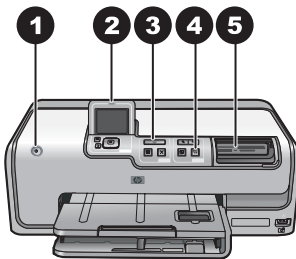

Indicator lights

1	On light: Solid blue if the printer is on, otherwise it is off.
2	Attention light: Flashes when there is an error condition. See the printer screen for instructions or information about the error. For more information, see The Attention light is on .
3	Print light: Solid blue when the printer is on and ready to print, flashes blue when the printer is printing or busy with self-maintenance.
4	Photo Fix light: Solid blue when the Photo Fix function is turned on.
5	Memory Card light: Solid blue if a memory card is inserted, flashes if the printer is accessing a memory card, off if no memory card is inserted or if more than one card is inserted. See the printer screen for instructions.

Optional accessories

There are several optional accessories available for the printer that enhance its portability for printing anywhere, anytime. The appearance of the accessories may vary from what is shown.

To purchase supplies, go to:

- www.hpshopping.com (U.S.)
- www.hp.com/go/supplies (Europe)
- www.hp.com/jp/supply_inkjet (Japan)
- www.hp.com/paper (Asia/Pacific)

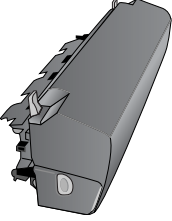
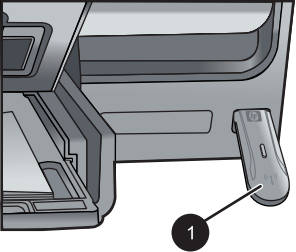
Accessory name	Description		
 <p data-bbox="224 743 607 798">HP Automatic Two-sided Printing Accessory</p>	<p data-bbox="690 499 1134 703">This accessory automatically flips each page to print on both sides. You will save money (two-sided printing reduces paper consumption) and time (no need to remove the paper and reinsert it to print on the back), plus you will make bulky documents more manageable.</p> <p data-bbox="690 711 1134 772">This accessory may not be available in all countries/regions.</p>		
 <p data-bbox="224 1102 667 1137">HP Bluetooth® wireless printer adapter</p> <table border="1" data-bbox="224 1137 667 1204"> <tr> <td data-bbox="224 1137 270 1204">1</td> <td data-bbox="270 1137 667 1204">Insert the Bluetooth adapter into the front camera port</td> </tr> </table>	1	Insert the Bluetooth adapter into the front camera port	<p data-bbox="690 824 1134 1024">The HP Bluetooth® wireless printer adapter goes into the camera port on the front of the printer. This adapter lets you use Bluetooth wireless technology for printing from many Bluetooth-enabled devices, including digital cameras, camera phones, and PDAs.</p> <p data-bbox="690 1032 1134 1119">For more information on printing with this accessory, go to www.hp.com/go/bluetooth.</p>
1	Insert the Bluetooth adapter into the front camera port		

Printer menu

Press the home button to access the home screen. You can access all of the functions from the home screen as well as setup menus.

View & Print

Wizard: Use the wizard to guide you through the printing process. Also use the wizard to improve photo quality and apply advanced photo effects such as brightness and color effects.

4×6: Use to print 4×6 inch (10 × 15 cm) photographs.

Enlargement: Use Enlargement to print different photo sizes.

Print All: Select to print all the photos from the memory card inserted in the printer.

Other Print Projects: Use Other Projects to print panoramic, HP CD/DVD Tattoos, wallet prints, and passport photos.

- **Panorama Prints:** Select to turn panoramic printing **On** or **Off** (default). Select **On** to print all selected photos with a 3:1 aspect ratio; load 10 x 30 cm (4 x 12 inch) paper before printing.
- **HP CD/DVD Tattoos:** Select to print labels for CD/DVDs.
- **Wallet Prints:** Use to print wallet-sized photos.
- **Passport Photos:** Select to print a passport photo.

Save

Select **Save** to save selected images to a connected PC.

Share

Use **Share** to select and share photos through HP Photosmart Share.

Settings

- **Tools:** Use tools to display the ink gauge, adjust the print quality, print a sample page, print a test page, and to clean and align cartridges.
 - Display Ink Gauge: Use to enable an ink supply gauge on the home screen.
 - **Print sample page:** Select to print a sample page, which is useful for checking the print quality of the printer. This feature is not available in all printer models.
 - **Print test page:** Select to print a test page containing information about the printer that can help in troubleshooting problems.
 - **Clean Printhead:** Select to clean the print head when white lines or streaks appear in your printouts. After the cleaning finishes, the printer prints a self test report. You have the option to clean the print head again if the report shows print quality problems.
 - **Align printer:** Select to align the printer when white lines or streaks appear in your printouts.
- **Bluetooth**
 - **Device address:** Some devices with Bluetooth wireless technology require you to enter the address of the device they are trying to locate. This menu option shows the printer address.
 - **Device name:** You can select a name for the printer that appears on other devices with Bluetooth wireless technology when they locate the printer.
 - **Passkey:** When the Bluetooth **Security level** of the printer is set to **High**, you must enter a passkey to make the printer available to other Bluetooth devices. The default passkey is 0000.
 - **Visibility:** Select **Visible to all** (default) or **Not visible**. When **Visibility** is set to **Not visible**, only devices that know the printer address can print to it.

- **Security level:** Select **Low** (default) or **High**. The **Low** setting does not require users of other devices with Bluetooth wireless technology to enter the printer passkey. **High** requires users of other devices with Bluetooth wireless technology to enter the printer passkey.
- **Reset Bluetooth options:** Select to reset all items in the Bluetooth menu to their default values.
- **Help Menu:** Use the help menu for instructions about using the printer.
 - **Cartridges:** Select to see an animation of how to install an ink cartridge.
 - **Main Tray Loading:** Select to read main tray paper loading instructions.
 - **Photo Tray Loading:** Select to read photo tray paper loading instructions.
 - **Paper jams:** Select to see an animation of how to clear a paper jam.
 - **Camera connect:** Select to read instructions on how to connect a PictBridge camera to the printer.
- **Preferences**
 - 4 × 6 print paper size: Choose **Ask before print** to select the paper type and size each time you print (default).
 - **Print quality:** Choose either **Best** (default) or **Normal** print quality.
 - **Paper Type:** Select **Automatic** (default) and the printer automatically detects the paper type and size.
 - **Date Stamp:** Use this option to include the date and/or time on your printed photos.
 - **Colorspace:** Choose a colorspace. The Auto-select default tells the printer to use the Adobe RGB colorspace, if available. The printer defaults to sRGB if Adobe RGB is not available.
 - **PictBridge Tray Select:** Use to select the default paper tray for printing through the PictBridge connection.
 - **Video enhancement:** Select **On** (default) or **Off**. When you select **On**, the quality of photos printed from video clips is improved.
 - **Restore Factory Defaults:** Restores factory settings for all menu items except **Select language** and **Select country/region** (under **Language** in **Preference** menu) and Bluetooth settings (under **Bluetooth** in the main printer menu). This setting does not affect HP Instant Share or Network defaults.

2 Get ready to print

This section includes the following topics:

- [Load paper](#)
- [Insert ink cartridges](#)
- [Insert memory cards](#)

Load paper

Learn how to choose the right paper for your print job and how to load it into the input tray for printing.

Choose the right paper

Use HP Advanced Photo Paper. It is especially designed to work with the inks in your printer to create beautiful photos.

For a list of available HP-designed photo paper, or to purchase supplies, go to:

- www.hpshopping.com (U.S.)
- www.hp.com/eur/hpoptions (Europe)
- www.hp.com/jp/supply_inkjet (Japan)
- www.hp.com/paper (Asia/Pacific)

The printer is set by default to print the best quality photos on HP Advanced Photo Paper. If you print on a different type of paper, be sure to change the paper type from the printer menu. See [Printer menu](#).

Paper loading tips

Paper loading tips:

- Load paper with the side to be printed facing down.
- You can print photos and documents on a wide variety of paper sizes, from 8 x 13 cm (3 x 5 inch) up to 22 x 61 cm (8.5 x 24 inch). The 10 x 15 cm (4 x 6 inch) photo paper is available with and without tabs.
- Before loading paper, pull the out main paper tray and slide out the paper-width and paper-length guides to make room for the paper. After loading paper, adjust the guides to fit close to the edges of the paper without bending the paper. When finished loading paper, push the main tray back in all the way.
- Load only one type and size of paper at a time in the same tray.
- After loading paper, extend the output tray extension and raise the backstop to catch your printed pages.

Load the main tray

Any supported photo or plain paper media

1. Extend the main tray.
2. Slide the paper-width and paper-length guides to their outermost positions.
3. Load paper with the side to be printed facing down. Make sure the stack of paper fits loosely under the tab on the paper-length guide.

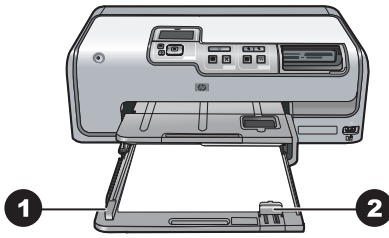

- | | |
|---|--------------------|
| 1 | Paper-width guide |
| 2 | Paper-length guide |

- Adjust the paper-width and paper-length guides inward until they stop at the edges of the paper.
- Push the main tray all the way in.

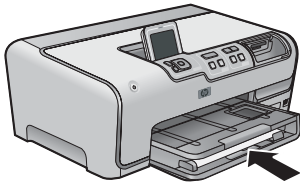

- | | |
|---|-----------------------------------|
| 1 | Push in the main tray all the way |
|---|-----------------------------------|

Load the photo tray

Use photo paper up to 10 x 15 cm (4 x 6 inch) with or without tabs, Hagaki cards, A6 cards, and L-size cards.

- Lift the output tray and extend the photo tray.
- Adjust the paper-width and paper-length guides outward to make room for the paper.

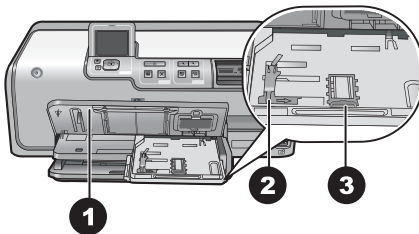

- | | |
|---|--------------------|
| 1 | Output tray |
| 2 | Paper-width guide |
| 3 | Paper-length guide |

- Load up to 20 sheets of paper into the photo tray with the print side down. If you are using tabbed paper, insert the paper so the tab is closer to you.
- Adjust the paper-width and paper-length guides inward until they stop at the edges of the paper. Make sure the stack of paper fits loosely under the tab on the paper-length guide.
- Push in the photo tray.
- Close the output tray.

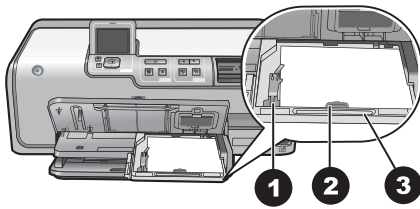

1	Paper-width guide
2	Paper-length guide
3	Photo tray grip.

Insert ink cartridges

The first time you set up and use your HP Photosmart, make sure to install the ink cartridges that were shipped with your printer. The ink in these ink cartridges is specially formulated to mix with the ink in the print head assembly.

Purchasing replacement ink cartridges

When purchasing replacement cartridges, refer to the cartridge numbers that appear on the back cover of this guide. These cartridge numbers may vary by country/region.



Note If you have already used the printer several times and you have installed the HP Photosmart printer software, you can also find the cartridge numbers in the printer software. **Windows users:** Right-click the HP Digital Imaging Monitor icon in the Windows taskbar, and select **Launch/Show HP Solution Center**. Select **Settings**, then **Print Settings**, and then **Printer Toolbox**. Click the **Estimated Ink Levels** tab, and then click **Ink Cartridge Information**. To order ink cartridges, click **Shop Online**. **Mac users:** Click **HP Photosmart Studio** in the Dock. In the HP Photosmart Studio toolbar, click **Devices**. From the **Information and Settings** pop-up menu, choose **Maintain Printer** and then click **Launch Utility**. In the **Configuration Settings** list, click **Supply Info**.

Ink cartridge tips

HP Vivera Inks deliver true-to-life photo quality and exceptional fade resistance resulting in vivid colors that last for generations! HP Vivera Inks are specially-formulated and scientifically tested for quality, purity and fade resistance.

For best print quality, HP recommends that you install all retail ink cartridges before the install-by date stamped on the box.

For optimum printing results, HP recommends using only genuine HP ink cartridges. Genuine HP ink cartridges are designed and tested with HP printers to help you easily produce great results, time after time.



Note HP cannot guarantee the quality or reliability of non-HP ink. Printer service or repairs required as a result of printer failure or damage attributable to the use of non-HP ink will not be covered under warranty.

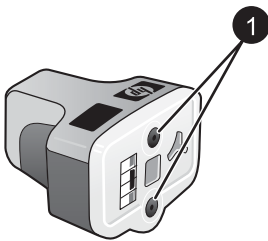

Ink cartridge

1	Do not insert objects into these holes
---	--



Caution To prevent ink loss or spillage: leave the ink cartridges installed while transporting the printer, and avoid leaving used ink cartridge(s) out of the printer for extended lengths of time.

Ink cartridge warranty information

The HP ink cartridge(s) warranty is applicable when the product is used in its designated HP printing device. This warranty does not cover HP ink products that have been refilled, remanufactured, refurbished, misused, or tampered with.

During the warranty period the product is covered as long as the HP ink is not depleted and the end of warranty date has not been reached. The end of warranty date, in YYYY/MM/DD format, may be found on the product as indicated:

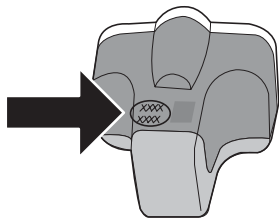

For a copy of the HP Limited Warranty Statement, see [HP Warranty](#).

Inserting or replacing the ink cartridges

1. Make sure the power is on, then lift the top cover. Make sure all packing material has been removed from inside the printer.

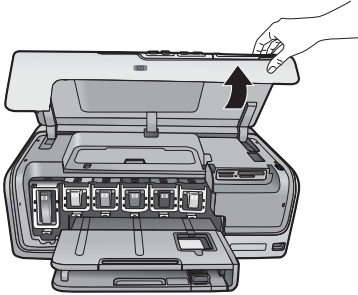

2. Squeeze the gray tab below an ink cartridge slot to release the gray latch inside the printer, then lift the latch.

The ink cartridge areas are color-coded for easy reference. Lift the latch below the appropriate color to insert or replace a cartridge. From left to right, the ink cartridges are black, yellow, light cyan, cyan, light magenta, and magenta.

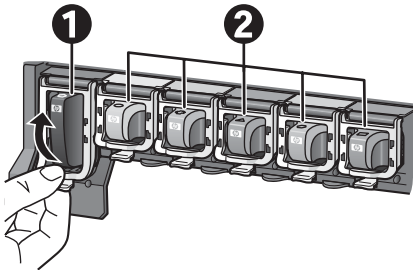

- | | |
|---|---|
| 1 | Ink cartridge latch for the black ink cartridge |
| 2 | Ink cartridge area for the color ink cartridges |

3. If you are replacing a cartridge, remove the old cartridge by pulling it toward you out of its slot.

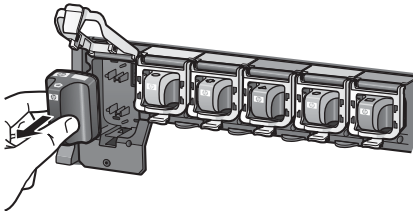

Recycle the old cartridge. The HP Inkjet Supplies Recycling Program is available in many countries/regions and lets you recycle used ink cartridges free of charge. For more information, go to www.hp.com/hpinfo/globalcitizenship/environment/recycle/inkjet.html.

4. Remove the new ink cartridge from its packaging, and while holding it by the handle, slide the ink cartridge into the empty slot.

Make sure you insert the ink cartridge into the slot that has the same shaped icon and color as the new cartridge. The copper-colored contacts should be facing the printer as the ink cartridge is inserted.



Note The first time you set up and use the printer, make sure to install the ink cartridges that were shipped with your printer. The ink in these ink cartridges is specially formulated to mix with the ink in the print head assembly.

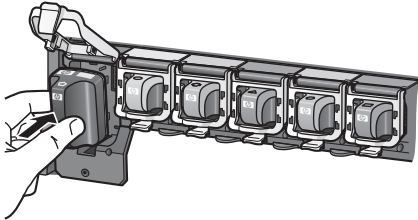

5. Press down on the gray latch until it clicks into place.

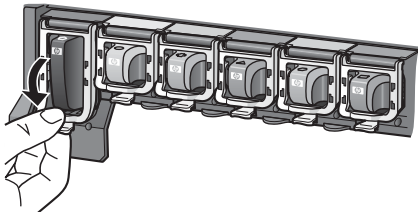

6. Repeat steps 2 through 5 for each ink cartridge you are replacing. You must install all six cartridges. The printer will not work if an ink cartridge is missing.
7. Close the top cover.

Insert memory cards

After you have taken pictures with a digital camera, you can remove the memory card from the camera and insert it into the printer to view and print your photos. The printer can read the following types of memory cards: CompactFlash™, Memory Sticks, Microdrive™, MultiMediaCard™, Secure Digital™, and xD-Picture Card™.



Caution Using any other type of memory card may damage the memory card and the printer.

To learn about other ways of transferring photos from a digital camera to the printer, see [Connecting to other devices](#).

Supported file formats

The printer can recognize and print the following file formats directly from a memory card: JPEG, uncompressed TIFF, Motion JPEG AVI, Motion-JPEG QuickTime, and MPEG-1. If your digital camera saves photos and video clips in other file formats, save the files to your computer and print them using a software program. For more information, see the electronic Help.

Inserting a memory card

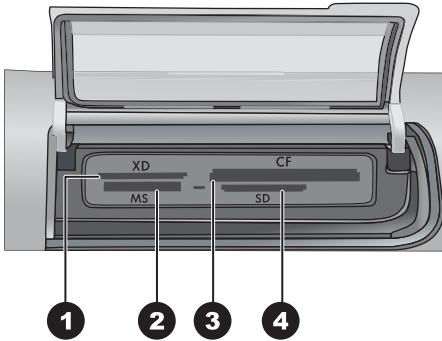

Memory card slots

1	xD-Picture Card
2	Memory Stick
3	Compact Flash I and II, Microdrive
4	Secure Digital, MultiMediaCard (MMC)

Memory card types

Find your memory card in the following table and use the instructions to insert the card into the printer.

Guidelines:





- Insert only one memory card at a time.
- Gently push the memory card into the printer until it stops. The memory card slot allows for only a portion of the card to insert into the printer; do not try to force the memory card all the way into the printer.
- When the memory card is inserted correctly, the memory card light flashes and then remains solid green.

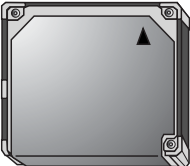

Caution 1 Inserting the memory card any other way may damage the card and the printer.

Caution 2 Do not pull out a memory card while the memory card light is flashing green. For more information, see [Removing a memory card](#).

Memory card	How to insert the memory card
CompactFlash 	<ul style="list-style-type: none">• Front label faces up, and if the label has an arrow, the arrow points toward the printer• Edge with metal pinholes goes into the printer first

Memory card	How to insert the memory card
<p data-bbox="123 170 287 194">Memory Stick</p>  <p>A vertical, rectangular Memory Stick card with a small white triangle pointing upwards at the top left corner.</p>	<ul data-bbox="413 170 1156 314" style="list-style-type: none">• Angled corner is on the left• Metal contacts face down• If you are using a Memory Stick Duo or Memory Stick PRO Duo card, attach the adapter that came with the card before you insert the card into the printer
<p data-bbox="123 442 249 466">Microdrive</p>  <p>A square Microdrive card with a small white triangle pointing upwards at the top center. It has metal pinholes at the corners.</p>	<ul data-bbox="413 442 1156 529" style="list-style-type: none">• Front label faces up, and if the label has an arrow, the arrow points toward the printer• Edge with metal pinholes goes into the printer first
<p data-bbox="123 673 306 697">MultiMediaCard</p>  <p>A rectangular MultiMediaCard with a small white triangle pointing upwards at the top left corner.</p>	<ul data-bbox="413 673 766 730" style="list-style-type: none">• Angled corner is on the right• Metal contacts face down
<p data-bbox="123 873 287 897">Secure Digital</p>  <p>A rectangular Secure Digital card with a small white triangle pointing upwards at the top left corner.</p>	<ul data-bbox="413 873 766 930" style="list-style-type: none">• Angled corner is on the right• Metal contacts face down
<p data-bbox="123 1072 309 1097">xD-Picture Card</p>  <p>A rectangular xD-Picture Card with a small white triangle pointing upwards at the top center and a white label at the bottom.</p>	<ul data-bbox="413 1072 866 1130" style="list-style-type: none">• Curved side of card points toward you• Metal contacts face down

Removing a memory card

Wait until the Memory Card light stops flashing, then gently pull the memory card to remove it from the printer.



Caution Do not pull out a memory card while the Memory Card light is flashing. A flashing light means that the printer is accessing the memory card. Removing a memory card while it is being accessed may damage the printer and the memory card or corrupt the information on the memory card.

3 Printing photos without a computer

The HP Photosmart D7100 series printer lets you select, enhance, and print photos without even turning on the computer. Once you've set up the printer using the instructions in the *Quick Start Guide*, you can insert a memory card in the printer and print your photos using the buttons on the printer control panel.

You can also print photos directly from a digital camera. For more information, see [Print photos from a digital camera](#).

Printing photos

You can print photos without a computer in several different ways:

- Insert a memory card with photos on it into one of the memory card slots on the printer
- Connect a PictBridge digital camera to the camera port on the front of the printer
- Install the optional HP Bluetooth® wireless printer adapter and print from a digital camera with Bluetooth wireless technology

Print photos from a memory card

You can print photos from a memory card by inserting the card into the printer and using the printer control panel to view, select, enhance, and print photos. You can also print camera-selected photos—photos you marked for printing using a digital camera—directly from a memory card.

Printing from a memory card is quick and easy, and does not drain the digital camera batteries.

Print one or more photos

Before you begin, make sure that the memory card is inserted in the printer and the paper tray you want to use is loaded with the correct paper.

1. Select **View & Print**, then press **OK**.
2. Select **4×6** or **Enlargement** to select your desired photo size, then press **OK**.
3. Select your desired paper size, then press **OK**.
4. Select a layout then press **OK**.
5. Using the arrow keys, scroll through the available photos.
6. Press **OK** to select one or more images.
 - Press **Zoom** - to view up to 9 images on the printer screen.
 - Press the up arrow to increase the number of prints for the selected image.
7. Press **Print** to print the selected photographs.

Check the Photo tray light to verify that the correct tray is selected — the light should be off for the Main tray and on for the Photo tray.

Print all photos on the memory card

Before you begin, make sure that the memory card is inserted in the printer and the paper tray with the paper you want to use is loaded with the correct paper.

1. Select **View & Print**, then press **OK**.
2. Select **Print All**.
3. Select the desired paper size and press **OK**.
→ Select a layout and press **OK**.
4. Select **Print Now** and press **OK**.

Print camera-selected photos from a memory card

When you select photos for printing using a digital camera, the camera creates a Digital Print Order Format (DPOF) file that identifies the selected photos. The printer can read DPOF 1.0 and 1.1 files directly from a memory card.

1. Use the digital camera to select the photos you want to print. For more information, see the documentation that came with the camera.
2. If you select **default** as the photo layout with the camera, select **Layout** to select a photo layout.
If you select a photo layout other than **default** with the camera, photos print in the camera-selected layout regardless of the printer setting.
3. Load the desired paper.
4. Remove the memory card from the digital camera and insert it into the printer.
5. When a message appears on the printer screen asking if you want to print the camera-selected photos, press **OK**.

The photos you selected with the camera begin printing.

If the printer cannot find or read all of the camera-selected photos on the card, it prints the photos that it can read.

After printing, the printer deletes the DPOF file and unmarks the photos.

Print using the Wizard

The print wizard provides detailed instructions about selecting, sizing, editing, and printing photographs.



Note Use the wizard to improve photo quality and apply advance effects such as brightness and color effects.

1. Select **View & Print** and press **OK**.
2. Select **Wizard** and press **OK**.
3. Follow the prompts to print your desired photo or photos.

Print photos from video clips

You can view video clips on the printer screen, and select and print individual frames.

When you first insert a memory card containing a video clip, the printer uses the first frame of the video clip to represent the clip on the printer screen.

The printer recognizes video clips recorded in these formats:

- Motion-JPEG AVI
- Motion-JPEG QuickTime
- MPEG-1

The printer ignores video clips in any other format.

Before you begin, make sure that the memory card is inserted in the printer and the paper tray you want to use is loaded with the correct paper.

1. Select **View & Print** and press **OK**.
2. To select your desired photo size, select **4×6** or **Enlargement** then press **OK**.
3. Select your desired paper size and press **OK**.
4. Scroll to select the available videos using the left and right arrows.



Note Videos display a video camera icon in the center of the image.

5. Press the up arrow to play the video.
6. To select a frame to print, press the up arrow to pause the video. The video must be paused to select frames for printing.
7. Press **OK** to select the desired frame for printing.
8. Press **Print** to print the selected frames.

Print a photo index

A photo index shows thumbnail views and index numbers for up to 2000 photos on a memory card. Use plain paper instead of photo paper to reduce costs.

A photo index may be several pages long.

Before you begin, make sure that the memory card is inserted in the printer and the paper tray you want to use is loaded with the correct paper.

1. Select **View & Print** and press **OK**.
2. Select **Print All** and press **OK**.
3. Select 8.5×11 paper.
4. Select the index sheet icon (16 images per page) and press **OK**.

Stop printing

To stop a print job in progress, press **Cancel**.

Print photos from a digital camera

You can print photos by connecting a PictBridge digital camera directly to the camera port of the printer with a USB cable. If you have a digital camera with Bluetooth wireless technology, you can insert the optional HP Bluetooth® wireless printer adapter in the printer and send photos to the printer wirelessly.

When you print from a digital camera, the printer uses the settings that you selected on the camera. For more information, see the documentation that came with the camera.

Digital camera with Bluetooth wireless technology

If you have a digital camera with Bluetooth wireless technology, you can purchase the optional HP Bluetooth® wireless printer adapter and print from a camera using a Bluetooth wireless connection.

(continued)



Note You can also print from other devices with Bluetooth wireless technology, such as PDAs and camera phones. For more information, see [Connecting to other devices](#) and the documentation that came with your Bluetooth adapter.

1. Set the Bluetooth options for the printer using the Bluetooth menu on the display. For more information, see [Settings](#).
2. Load printer paper.
3. Insert the HP Bluetooth® wireless printer adapter into the camera port on the **front** of the printer.
The light on the adapter flashes when the adapter is ready to receive data.
4. Follow the instructions in the documentation that came with the digital camera to send photos to the printer.

Digital camera with PictBridge technology

1. Turn on the PictBridge digital camera and select the photos you want to print.
2. Load paper.
3. Make sure the camera is in PictBridge mode, then connect it to the camera port on the **front** of the printer using the USB cable that came with the camera.
Once the printer recognizes the PictBridge camera, the selected photos print automatically.

Print photos from an iPod

If you have an iPod that can store photos, you can connect your iPod to the printer and print the photos.

Before you begin

Check that the images you copy to the iPod are in JPEG format.



Note iPods might not be available in your country/region.

To import photos to an iPod



1. Copy photos from a memory card to your iPod using the Belkin Media Reader for iPod.
2. Verify that photos are on your iPod by selecting **Photo Import** on the iPod menu. Photos appear as **Rolls**.

To print photos from an iPod

1. Connect the iPod to the camera port on the **front** of the printer using the USB cable that came with the iPod. The printer screen displays **Reading Device** for several minutes while the photos are read. Then the photos appear on the printer screen.
2. Select the photo(s) you want to print and press **Print**. For more information on selecting and printing photos, see [Printing photos](#).

Photo layouts

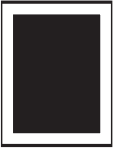
Select the desired print function from the View & Print menu and press **OK**, choose your desired print function, then select your desired paper size to select a layout.

Layout	Paper size (photo size)
<p>1 per page borderless</p> 	<p>4 x 6 inch (4 x 6 inch) 10 x 15 cm (10 x 15 cm) 5 x 7 inch (5 x 7 inch) 8.5 x 11 inch (8.5 x 11 inch)</p>
<p>1 per page</p> 	<p>3.5 x 5 inch (3.25 x 4.75 inch) 4 x 6 inch (3.75 x 5.75 inch) 10 x 15 cm (9.53 x 14.6 cm) 5 x 7 inch (4.75 x 6.75 inch) 8 x 10 inch (7.75 x 9.75 inch) 8.5 x 11 inch (8 x 10 inch) A6 (9.86 x 14.16 cm) A4 (20 x 25 cm) Hagaki (9.36 x 14.16 cm) L (8.25 x 12.06 cm)</p>
<p>2 per page</p> 	<p>3.5 x 5 inch (2.25 x 3.25 inch) 4 x 6 inch (2.75 x 3.75 inch) 5 x 7 inch (3.25 x 4.75 inch) 8 x 10 inch (4.75 x 6.5 inch) 8.5 x 11 inch (5 x 7 inch) A6 (6.92 x 9.86 cm) A4 (13 x 18 cm) Hagaki (6.8 x 9.36 cm) L (5.87 x 8.25 cm)</p>
<p>3 per page</p> 	<p>3.5 x 5 inch (1.5 x 2.25 inch) 4 x 6 inch (1.75 x 2.625 inch) 5 x 7 inch (2.25 x 3.375 inch) 8 x 10 inch (3.33 x 5 inch) 8.5 x 11 inch (4 x 6 inch) A6 (4.77 x 7.15 cm) A4 (10 x 15 cm) Hagaki (4.52 x 6.78 cm) L (3.96 x 5.94 cm)</p>
<p>4 per page</p>	<p>3.5 x 5 inch (1.5 x 2.25 inch) 4 x 6 inch (1.75 x 2.5 inch) 5 x 7 inch (2.2 x 3.25 inch)</p>

(continued)

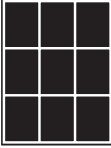
Layout	Paper size (photo size)
	8 x 10 inch (3.5 x 4.75 inch) 8.5 x 11 inch (3.5 x 5 inch) A6 (4.77 x 6.92 cm) A4 (9 x 13 cm) Hagaki (4.52 x 6.5 cm) L (3.96 x 5.7 cm)
9 per page 	3.5 x 5 inch (1 x 1.375 inch) 4 x 6 inch (1.125 x 1.5 inch) 5 x 7 inch (1.5 x 2 inch) 8 x 10 inch (2.25 x 3 inch) 8.5 x 11 inch (2.5 x 3.25 inch) – Wallet size A6 (3.07 x 4.05 cm) A4 (6.4 x 8.4 cm) Hagaki (2.9 x 3.86 cm) L (2.53 x 3.36 cm)



Note The printer may rotate the photos to fit the layout.

Improving photo quality

The printer provides a variety of enhancements that can improve the quality of a photo printed from a memory card. These print settings do not change the original photo. They only affect printing.

Adjust photos with poor brightness

1. Select **View & Print** and press **OK**.
2. Select **Wizard** and press **OK**.
3. Follow the onscreen instructions to select your paper size and photo, then press **OK** to view the menu.
4. Select **Edit Photo** and press **OK**.
5. Select **Photo Brightness** and press **OK**.
6. Press ◀ and ▶ to increase or decrease the photo brightness to the desired level, then press **OK**.

Remove red eye from photos

The automatic red eye removal feature is enabled when you turn on the Photo fix function. Enabling the Photo Fix function applies Smart Focus, Adaptive Lighting, and red eye removal features to selected photos.

- Press **Photo Fix** to enable the Photo Fix function.

Adjust poor-quality video clips

This preference affects photos printed from video clips.

Improve the quality of photos printed from video clips

1. Select **Settings** and press **OK**.
2. Using the arrow keys, find and select **Preferences** and press **OK**.
3. Using the arrow keys, find and select **Video Enhancement** and press **OK**.
4. Select **On**, then press **OK**.

For information about printing photos from video clips, see [Print photos from a memory card](#).

Getting creative

The printer provides a variety of tools and effects that let you use your photos in creative ways. These print settings do not change the original photo. They only affect printing.

Add a color effect

You can set the printer to change the color option applied to a photo from **Color** (default) to **Black & white**, **Sepia**, or **Antique**.

Photos printed in **Sepia** print in brown tones and look similar to photos produced in the early 1900s. Photos printed in **Antique** print in the same brown tones, but with some pale colors added to give the appearance that the photos are hand-colored.

1. Select **View & Print** and press **OK**.
2. Select **Wizard** and press **OK**.
3. Follow the onscreen instructions to select your paper size and photo, then press **OK**.
4. Select **Done Selecting** and press **OK**.
5. Select **Edit Photo** and press **OK**.
6. Select **Color Effect** and press **OK**.
7. Select the desired color effect and press **OK**.

Add the date and time to your prints

You can print a stamp on the front of your photos that shows when the photo was taken. This preference affects all prints.

1. Select **Settings** and press **OK**.
2. Using the arrow keys, find and select **Preferences** and press **OK**.
3. Select **Date Stamp** and press **OK**.
4. Select one of the following date/time stamp options:
 - **Date and Time**
 - **Date Only**
 - **Off**

If you use a computer to modify the photo and then save your changes, the original date and time information are lost. Changes that you make to the photo using the printer control panel do not affect the date and time information.

Change the print quality

You can change the print quality for photos. Best quality is the default and produces the highest quality photos. Normal quality conserves ink and prints faster.

To change the print quality:

1. Select **Settings** and press **OK**.
2. Select **Preferences** and press **OK**.
3. Select **Print quality** and press **OK**.
4. Select the desired print quality and press **OK**.

Print quality will revert to Best after the next print job.

Crop a photo

Press **Zoom +** and **Zoom –** to increase or decrease the magnification by 1.25×. The maximum level is 5.0×.

1. Select **View & Print** and press **OK**.
2. Select **4×6** or **Enlargement** to select your desired photo size and press **OK**.
3. Select the desired paper size and press **OK**.
4. Select the desired photo and press **OK**.
5. Press **Zoom +** to increase the magnification of the photo by 1.25×. The green crop box appears. Press **Zoom +** repeatedly until you reach the desired magnification. (After zooming in, you can zoom back out by pressing **Zoom –**.)



Note The crop box changes from green to yellow if printing at the selected magnification will noticeably reduce the print quality.

6. At any magnification level, press the arrows to move the crop box left, right, up, or down.
7. Press **OK** when the portion of the image you want to print is in the crop box. Cropping does not change the original photo. It only affects printing.

Print panoramic photos

1. Select **View & Print** and press **OK**.
2. Select **Other Projects** and press **OK**.
3. Select **Panorama Prints** and press **OK**.
4. Follow the prompt to load 10 x 30 cm (4 x 12 inch) media, then press **OK**.
5. Select a photo and press **OK**. If desired, crop the photo before printing. The crop box has a 3:1 aspect ratio.



Note All photos printed in panoramic mode are printed borderless.

4 Getting connected

Use the printer to stay connected to other devices and people.

Connecting to other devices

This printer offers several ways of connecting to computers or other devices. Each connection type lets you do different things.

Connection type and what you need	This lets you...
<p>Memory cards</p>  <p>A memory card</p> <p>A compatible digital camera memory card Insert the memory card into the appropriate memory card slot on the front of the printer.</p>	<ul style="list-style-type: none">• Print directly from a memory card to the printer.• Save photos from a memory card inserted in the printer to a computer where you can enhance or organize them in the HP Photosmart Premier or other software. For more information, see Saving photos to a computer and Print photos from a memory card.
<p>USB</p> <ul style="list-style-type: none">• A Universal Serial Bus (USB) 2.0 full-speed compliant cable 3 meters (10 feet) or less in length. For instructions about connecting the printer with a USB cable, see the <i>Quick Start</i> booklet.• A computer with Internet access (to use HP Photosmart Share).	<ul style="list-style-type: none">• Print from a computer to the printer. See Printing from a computer.• Save photos from a memory card inserted in the printer to a computer where you can enhance or organize them in the HP Photosmart Premier or other software.• Share photos through HP Photosmart Share.• Print directly from an HP Photosmart direct-printing digital camera to the printer. For more information, see Print photos from a digital camera and the camera documentation.
<p>PictBridge</p>	<p>Print directly from a PictBridge-compatible digital camera to the printer.</p> <p>For more information, see Print photos from a digital camera and the camera documentation.</p>

(continued)

Connection type and what you need	This lets you...
 <p>The PictBridge symbol</p> <p>A PictBridge-compatible digital camera and a USB cable.</p> <p>Connect the camera to the camera port on the front of the printer.</p>	
<p>Bluetooth</p> <p>The optional HP Bluetooth wireless printer adapter.</p> <p>If the printer came with this accessory or you have purchased it separately, see the accompanying documentation and the onscreen Help for instructions.</p>	<p>Print from any device with Bluetooth wireless technology—such as a digital camera, a camera phone, or a PDA—to the printer.</p> <p>If you connect the optional HP Bluetooth wireless printer adapter to the printer through the camera port, be sure to set the Bluetooth printer menu options as needed. See Settings.</p>
<p>iPod</p> <p>An iPod and the USB cable that came with it. Connect the iPod to the camera port on the front of the printer.</p>	<p>Print directly from an iPod (with photos stored in it) to the printer. For more information, see Print photos from an iPod.</p>

Saving photos to a computer

You can save photos to a computer from any memory card inserted in the printer, if you set up a USB connection between the two devices.

If you are using a Windows computer

Use either of these methods to save photos to your computer.

- Insert a memory card into the printer. The HP Photosmart Premier transfer software (HP Transfer and Quick Print) opens on your computer screen and allows you to designate a location on the computer to save images. For more information, see the onscreen HP Photosmart software help.
- Insert a memory card into the printer. The memory card appears in Windows Explorer as a removable drive. Open the removable drive and drag photos from the card to any location on your computer.

If you are using a Macintosh

1. Insert a memory card into the printer.
2. Wait for iPhoto to start and read the contents of the memory card.



Note iPhoto starts only if it is set as the default application.

3. Click **Import** to save the photos on the card to your Macintosh.



Note The memory card also appears on the desktop as a drive icon. You can open it and drag photos from the card to any location on your Macintosh.

Connecting through HP Photosmart Share

Use HP Photosmart Share to share photos with friends and relatives using e-mail, online albums, or an online photo finishing service. Your printer must be connected through a USB cable to a computer with Internet access and have all the HP software installed. If you try to use Share and do not have all the required software installed or configured, a message prompts you through the required steps.

Use Share (USB) to send photos (Windows users):

1. Insert a memory card and select some photos.
2. Select **Share** on the printer screen and press **OK**.
3. Follow the instructions on your computer to share the selected photos with others.

Use Share (USB) to send photos (Mac users)

1. Open **HP Photosmart Studio** and select photos to share. For information about HP Photosmart Studio, see [HP Photosmart Premier \(Windows users\)](#).
2. In the HP Photosmart Studio toolbar, click **Share**.
3. Click **Continue**, and follow the instructions on your computer to share the selected photos with others.

See the onscreen software help for more information about using HP Photosmart Share

5 Printing from a computer

To print from a computer, the printer software must be installed. During software installation, either HP Photosmart Premier (Windows Full-install users), HP Photosmart Essential (Windows Express-install users) or the HP Photosmart Studio (Mac) is installed on your computer, allowing you to organize, share, edit, and print photos.

For more information on installing the software, see the *Quick Start Guide*. Update the software regularly to ensure you have the latest features and improvements; for instructions, see [Update the software](#).

To work with photos, you need to transfer them to a computer that is connected to the printer. See [Saving photos to a computer](#).



Note Windows users: HP Photosmart Premier can only be used on computers with processors that have Intel® Pentium® III (or equivalent) and higher.

Using creative options in the printer software

Read through these tips on how to open and use HP Photosmart Premier, HP Photosmart Essential, HP Photosmart Studio (Mac), and HP Photosmart Share.

HP Photosmart Premier (Windows users)

HP Photosmart Premier is an easy-to-use software program that gives you everything you need to have fun with your photos, in addition to basic photo editing and printing. This software also gives you access to HP Photosmart Share so that you can easily share your photos.

Open HP Photosmart Premier

→ Double-click the **HP Photosmart Premier** icon on your desktop. If you need help, see the software help within HP Photosmart Premier.

Explore the many features of HP Photosmart Premier:

- **View** — View photos in multiple sizes and ways. Easily organize and manage your photos.
- **Edit** — Crop your photos and fix photos with red eye. Automatically adjust and enhance your photos in different sizes and in multiple layouts.
- **Print** — Print your photos in different sizes and in multiple layouts.
- **Share** — Send photos to family and friends without the bulky attachments using HP Photosmart Share, a better way to send e-mail.
- **Create** — Easily create album pages, cards, calendars, panoramic photos, CD labels, and more.
- **Back-up** — Make back-up copies of your photos to store and save.

HP Photosmart Essential (Windows users)

HP Photosmart Essential is an easy-to-use software program that gives you basic photo editing and printing capabilities. This software also gives you access to HP Photosmart Share so that you can easily share your photos. HP Photosmart Essential is only available for Windows users.

Open HP Photosmart Essential

- Double-click the **HP Photosmart Essential** icon on your desktop. If you need help, see the software help within HP Photosmart Essential.

Explore the many features of HP Photosmart Essential:

- **View** — View photos in multiple sizes and ways. Easily organize and manage your photos.
- **Edit** — Crop your photos and fix photos with red eye. Automatically adjust and enhance your photos to make them perfect.
- **Print** — Print your photos in different sizes and in multiple layouts.
- **Share** — Send photos to family and friends without the bulky attachments with HP Photosmart Share, a better way to send e-mail.

HP Photosmart Studio (Macintosh Users)

- Click the **HP Photosmart Studio** icon in the Dock.

Explore the many features of the HP Photosmart Mac software that is accessible from the HP Photosmart Studio:

- **Import** — Import photos or videos from an HP digital camera.
- **View and Manage** — View, organize, and manage your photos and videos.
- **Edit** — Adjust and enhance your images.
- **Slideshow** — Create an online slideshow of your photos.
- **Panorama** — Create a single panoramic image from several images.
- **Create** — Create album pages, cards, labels, posters, banners, and more.
- **Print** — Print your photos and frames from video in standard sizes or in index sheet format.
- **Share** — Send photos to family and friends without the bulky attachments.
- **Shop** — Order online prints and gifts.

HP Photosmart Share

HP Photosmart Share allows you to send photos to family and friends without bulky e-mail attachments. For more information, see [Connecting through HP Photosmart Share](#) and the HP Photosmart Premier or HP Photosmart Essential help.

Open HP Photosmart Share (Windows users)

- Click the **HP Photosmart Share** tab within HP Photosmart Premier or HP Photosmart Essential.

Open HP Photosmart Share (Mac users)

- Click the **Applications** tab in HP Photosmart Premier, then double-click **HP Photosmart Share**.

Set print preferences

Print preferences are set by default, but can be altered to suit your needs. You can set specific job settings when you print from the computer. When you change settings before printing, the changes only affect the current print job. In some Windows software programs, you need to click **Properties** or **Preferences** within the **Print** dialog box to access the advanced printing features. See the electronic Help for more information about printing preferences.

Access print preferences (Windows users)

1. Open the **Print** dialog box, usually by selecting **Print** from the **File** menu.
2. Change the printing preferences in the **Print** dialog box tabs, or click **Properties** or **Preferences** to access more printing preferences.

Access print preferences (Mac users)

1. Open the **Print** dialog box, usually by selecting **Print** from the **File** menu.
2. Change the printing preferences in the **Print** dialog box by selecting the print options you want to change in the **Copies & Pages** drop-down menu.

For more information on changing the printing preferences, see the electronic Help.

Open the electronic help

Windows users:

- Press F1 on your keyboard.
- For field-level help, click the ? in the top right corner of the **Print** dialog box.

Mac users:

1. From the **Finder**, choose **Help > Mac Help**.
2. Choose **HP Photosmart Mac Help** from the **Library** menu, and then choose the printer name in the **HP Photosmart Mac Help** table of contents.

HP Real Life technologies features

Explore the many photo editing and enhancing options in the HP Real Life technologies software features. These features—such as automatic red eye removal and adaptive lighting—make it easy for you to print high-quality photos.

There are three options available:

- The **Basic** setting sharpens images and improves the quality and clarity of low resolution images, such as those downloaded from the Internet.
- The **Full** setting improves images that are under exposed or over exposed, contain dark areas or red eye, or have colors that appear washed out.
- The **Off** setting lets you edit the image manually in a software program such as HP Photosmart software.

Access Real Life technologies features (Windows users)

1. Open the **Print** dialog box, usually by selecting **Print** from the **File** menu.
2. Click the **Paper/Quality** tab, then click the **Real Life Digital Photography** button —OR— Click the **Properties** or **Preferences** button, and then click the **Real Life Digital Photography** button.

Access Real Life technologies features (Mac users)

1. Open the **Print** dialog box, usually by selecting **Print** from the **File** menu.
2. Select **Real Life Digital Photography** from the **Copies & Pages** drop-down menu.

6 Care and maintenance

The printer requires very little maintenance. Follow the guidelines in this section to extend the life span of the printer and printing supplies, and to ensure that the photos you print are always of the highest quality.

- [Clean and maintain the printer](#)
- [Update the software](#)
- [Store and transport the printer and ink cartridges](#)
- [Maintain the quality of photo paper](#)

Clean and maintain the printer

Keep the printer and print cartridge clean and well maintained using the simple procedures in this section.

Clean the outside of the printer

1. Turn off the printer, then disconnect the power cord from the back of the printer.
2. Wipe the outside of the printer with a soft cloth that has been lightly moistened with water.



Caution Do not use any type of cleaning solution. Household cleaners and detergents may damage the printer finish. Do not clean the interior of the printer. Keep all fluids away from the interior. Do not lubricate the metal rod on which the print head slides. Noise is normal when the print head moves back and forth.

Aligning the printer

Use the following procedure when the self test report shows streaking or white lines through any of the blocks of color.

If you still have print quality problems after aligning the printer, try cleaning the print head using the procedure described in [Care and maintenance](#). If print quality problems persist after aligning and cleaning, contact HP Support.

1. Load letter or A4 unused plain white paper into the Main tray.
2. Select **Settings** and press **OK**.
3. Select **Tools** and press **OK**.
4. Scroll to find then select **Align printer**.
The printer aligns the print head, prints an alignment page, and calibrates the printer. Recycle or discard the alignment page.
5. Press **OK**.

Print a sample page

You can print a sample page to test the printer photo printing quality and to make sure the paper is loaded correctly.

1. Load paper in the Main tray. Use plain paper to conserve photo paper.
2. Select **Settings** and press **OK**.
3. Select **Tools** and press **OK**.
4. Select **Print sample page** and press **OK**.

Automatically clean the printhead

If you notice white lines or streaks on the photos you print, or in the color blocks of the self test report, use this procedure to clean the print head. Do not clean the print head unnecessarily, as this wastes ink and shortens the life of the ink nozzles on the print head.

1. Load paper in the Main tray. Use plain paper to conserve photo paper.
2. Select **Settings** and press **OK**.
3. Select **Tools** and press **OK**.
4. Select **Clean printhead** and press **OK**.

If print quality still seems poor after you clean the print head, try aligning the printer using the procedure described in [Aligning the printer](#). If print quality problems persist after cleaning and aligning, contact HP support.

Manually clean the ink cartridge contacts

Clean the copper-colored ink cartridge contacts if a message appears on the printer screen that says a cartridge is missing or damaged.

Before cleaning the ink cartridge contacts, remove the ink cartridge and verify that nothing is covering the ink cartridge contacts or the ink cartridge slot, then reinstall the ink cartridge. If you continue to get a message that says a cartridge is missing or damaged, clean the ink cartridge contacts. If you still get this message after cleaning the contacts, you will need a replacement ink cartridge. Remove the affected ink cartridge and look at the end-of-warranty date on the bottom, in YYYY/MMM/DD format. If it is before the end-of-warranty date, contact HP support to obtain a replacement ink cartridge.

To clean the ink cartridge contacts:

1. Gather the following items to clean the contacts:
 - Distilled, filtered, or bottled water (tap water may contain contaminants that can damage the ink cartridge)



Caution Do not use platen cleaners or alcohol to clean the ink cartridge contacts. These can damage the ink cartridge or the HP Photosmart printer.

- Dry foam rubber swabs, lint-free cloth, or any soft material that will not come apart or leave fibers.
2. Open the top cover of the printer.
 3. Squeeze the gray tab below an ink cartridge slot to release the gray latch inside the printer, then lift the latch.



Caution Do not remove multiple ink cartridges at the same time. Remove and clean each ink cartridge one at a time. Do not leave the ink cartridge outside the printer for more than 30 minutes.

4. Lightly moisten a swab or cloth with water and squeeze out any excess water.
5. Hold the ink cartridge by its handle and gently wipe only the copper-colored contacts with the swab or cloth.

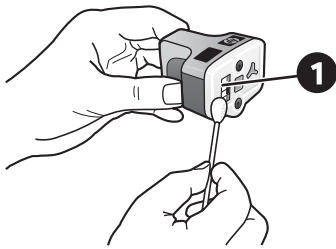

1 Gently wipe only the copper-colored contacts

6. Place the ink cartridge back into the empty slot and press down on the gray latch until it clicks into place.
7. Repeat if necessary for the other ink cartridges.
8. Close the top cover.



Caution The ink supply may become pressurized. Inserting a foreign object into the ink supply could result in ink being expelled and coming in contact with persons or property.

Print a self test report

If you are experiencing problems with printing, print a self test report. This two-page report—labelled the Extended Self Test Diagnostic Page—can help you diagnose printing problems and can provide valuable information if you need to call HP Support. You can also use this report to check on the approximate percentage of ink remaining in the ink cartridges.

1. Select **Settings** and press **OK**.
2. Select **Tools** and press **OK**, then scroll to Print test page.
3. Select **Print test page** and press **OK**.

The HP Photosmart prints a two-page self test report that contains the following information:

- **Product information:** Includes the model number, serial number, and other product information.
- **Revision information:** Includes the firmware version number and indicates whether or not you have an HP two-sided printing accessory (duplexer) installed.
- **Ink delivery system information:** Displays the approximate ink level of each installed ink cartridge, the status of each ink cartridge, the date each cartridge was installed, and the expiration date for each cartridge.
- **Print head assembly information:** Contains information that may be used for diagnostic purposes if you need to call HP Support.
- **Print head parameters:** Contains information that may be used for diagnostic purposes if you need to call HP Support.
- **Print quality pattern:** Displays six color blocks, representing each of the six installed cartridges. When streaks appear through the color blocks, or there are missing color blocks, clean the print head using the procedure described in [Care and maintenance](#). If the color blocks still show print quality problems after cleaning the print head, align the printer using the procedure described in [Aligning the printer](#). If the color blocks continue to show print quality problems after cleaning and aligning, contact HP support.
- **History log:** Contains information that may be used for diagnostic purposes if you need to call HP Support.

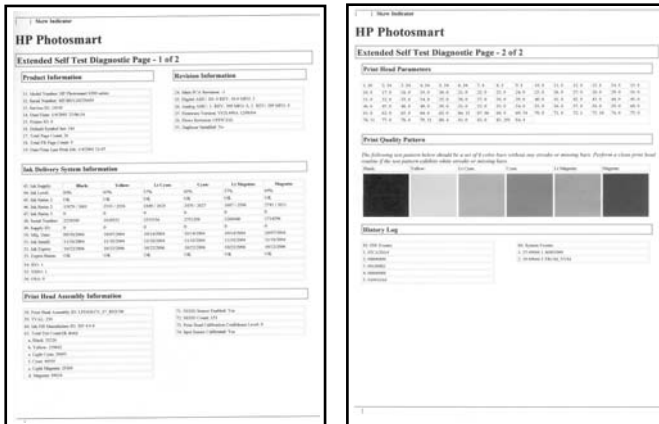

Self test report

Update the software

Download the latest printer software update periodically to ensure you have the latest features and improvements. You can download printer software updates by going to www.hp.com/support or by using HP Software Update.



Note The printer software update that you download from the HP Web site does not update the HP Photosmart Premier software.

Downloading the software (Windows)



Note Make sure you are connected to the Internet before you use HP Software Update.

1. From the Windows **Start** menu, select **Programs** (in Windows XP, select **All Programs**) > **Hewlett-Packard** > **HP Software Update**. The HP Software Update window opens.
2. Click **Check Now**. HP Software Update searches the HP Web site for printer software updates. If the computer does not have the most recent version of the printer software installed, a software update appears in the HP Software Update window.



Note If the computer has the most recent version of the printer software installed, the following message appears in the HP Software Update window: “No updates are available for your system at this time”.

3. If a software update is available, click the checkbox next to the software update to select it.
4. Click **Install**.
5. Follow the onscreen instructions to complete the installation.

Downloading the software (Mac)



Note Make sure you are connected to the Internet before you use HP Photosmart Updater.

1. On your Mac in the Finder, choose **Go > Applications**.
2. Choose **Hewlett-Packard > Photosmart > HP Photosmart Updater**.
3. Follow the onscreen instructions to check for software updates.
If you are behind a firewall, you need to enter the proxy server information in the updater.

Store and transport the printer and ink cartridges

Protect the printer and ink cartridges by storing them properly when you are not using them.

Store and transport the printer

The printer is built to withstand long or short periods of inactivity. Store the printer indoors out of direct sunlight in a place without temperature extremes.



Caution To prevent ink loss or spillage: do not transport or store the printer on its side, and leave the ink cartridges installed while storing and transporting the printer.

Store and transport the ink cartridges

When you transport or store the printer, always leave the active ink cartridge inside the printer to prevent the ink from drying out.



Caution 1 To prevent ink loss or spillage: leave the ink cartridges installed while storing and transporting the printer, and avoid leaving used ink cartridge(s) out of the printer for extended lengths of time.

Caution 2 Make sure the printer completes its power-down cycle before you unplug the power cord. This allows the printer to store the print head properly.

Follow this tip to help maintain your HP ink cartridges and ensure consistent print quality: Keep all unused ink cartridges in their original sealed packages until they are needed. Store ink cartridges at room temperature (15-35 °C or 59-95 °F).

Maintain the quality of photo paper

For best results with photo paper, follow the guidelines in this section.

To store photo paper

- Store the photo paper in its original packaging or in a resealable plastic bag.
- Store the packaged photo paper on a flat, cool, and dry surface.
- Return unused photo paper to the plastic bag. Paper left in the printer or exposed to the elements may curl.

To handle photo paper

- Always hold photo paper by the edges to avoid fingerprints.
- If the photo paper has curled edges, place it in its plastic storage bag and gently bend it in the opposite direction of the curl until the paper lies flat.

7 Troubleshooting

The HP Photosmart printer is designed to be reliable and easy to use. This chapter answers frequently asked questions about using the printer and printing without a computer. It contains information about the following topics:

- [Printer hardware problems](#)
- [Printing problems](#)
- [Error messages](#)

For additional troubleshooting information, see:

- **Software installation troubleshooting:** The *Quick Start* guide that came with the printer.
- **Printer software and printing from a computer troubleshooting:** The onscreen HP Photosmart Printer Help. For information about viewing the onscreen HP Photosmart Printer Help, see [Welcome](#).

Printer hardware problems

Before contacting HP support, read this section for troubleshooting tips or go to the online support services at www.hp.com/support.



Note If you want to connect the printer to a computer with a USB cable, HP recommends using a 2.0 high-speed compliant cable 3 meters (10 feet) or less in length.

The Print light is flashing blue but the printer is not printing

Solution The printer is busy processing information; wait for it to finish.

The Attention light is on

Solution

- Check the printer screen for instructions. If a digital camera is connected to the printer, check the camera screen for instructions. If the printer is connected to a computer, check the computer monitor for instructions.
- Turn off the printer, then unplug its power cord. Wait about 10 seconds, then plug it in again. Turn on the printer.

If the Attention light stays on after trying the above solutions, go to www.hp.com/support, or contact HP Support for help.

The printer does not find the photos I stored on my memory card

Solution The memory card may contain file types the printer cannot read directly from the card.

- Save the photos to a computer, then print them from the computer. For more information, see the onscreen HP Photosmart help and the documentation that came with the camera.
- The next time you take photos, set the digital camera to save them in a file format the printer can read directly from the memory card. For a list of supported file formats, see [Printer specifications](#). For instructions on setting the digital camera to save photos in specific file formats, see the documentation that came with the camera.

The memory card may need to be reformatted if the problem persists.

The printer is plugged in but will not turn on

Solution

- The printer may have drawn too much power. Unplug the printer power cord. Wait about 10 seconds, then plug the cord back in. Turn on the printer.
 - The printer may be plugged into a power strip that is turned off. Turn on the power strip, then turn on the printer.
 - The power cord could be defective. Make sure the green light on the power cord is lit.
-

The printer makes noises when I turn it on, or starts making noises after sitting unused for a while

Solution The printer may make noises after long periods of inactivity (approximately 2 weeks) or when its power supply has been interrupted and then restored. This is normal operation. The printer is performing an automatic maintenance procedure to ensure it produces the best quality output.

All the lights are flashing on the printer

Solution The printer has encountered a hardware error and may need to be serviced. Unplug the power cord to the printer. Wait about 10 seconds, and then plug it in again. Turn on the printer. If the lights are still flashing, please go to www.hp.com/support, or contact HP Support for help.

Printing problems

Before contacting HP support, read this section for troubleshooting tips or go to the online support services at www.hp.com/support.

The printer does not print borderless photos when I print from the control panel

Solution Make sure the correct layout is selected when setting up the print job. When selecting photo and paper size, the image rectangle must be solidly filled with orange to indicate a borderless print.

Printing is very slow

Solution You may have one of the following situations: 1) you may be printing a PDF or a project containing high-resolution graphics or photos or 2) you may have selected the highest resolution for your printout. Large, complex projects containing graphics or photos print slower than text documents, especially at higher resolutions.

Paper does not feed into the printer correctly from the Main tray

Solution

- There may be too much paper loaded in the tray. Remove some paper and try printing again.
 - The Main tray may not be pushed in all the way. Push the Main tray all the way in.
 - The paper guides may not be adjusted correctly. Make sure the paper-width and paper-length guides fit close to the edges of the paper without bending the paper.
 - Two or more pieces of paper may be sticking together. Remove the paper from the Main tray, fan the edges of the stack to separate the sheets of paper, then reload the paper and try printing again.
 - If the paper is wrinkled or bent, try using different paper.
 - The paper may be too thin or too thick. Use HP inkjet paper for best results. For more information, see [Choose the right paper](#).
-

Printed pages are dropping off of the Output tray

Solution Always extend the Output tray extension when you print.

The printout is rippled or curled

Solution The project you are printing uses a larger amount of ink than normal. Print the project from a computer, and use the printer software to lower the ink saturation level. See the onscreen HP Photosmart help for more information.

The document printed at an angle or is off-center

Solution

- The paper may not be loaded correctly. Reload the paper, making sure it is correctly oriented in the Main tray and that the paper-width and paper-length

guides fit close to the edges of the paper. For paper-loading instructions, see [Paper loading tips](#).

- If you are using a two-sided printing accessory, try removing it, replacing the rear access door, and printing again.
 - The printer may need to be aligned. For more information, see [Aligning the printer](#).
-

Colors are not printing satisfactorily

Solution

- One of the color ink cartridges may be empty, resulting in another color being substituted during printing. Check the estimated ink levels by viewing the ink level icons from the Tools menu (Settings > Tools > Display Ink Gauge). If an ink cartridge is empty, replace it. For more information, see [Insert ink cartridges](#).
 - The printer may need to be aligned. For more information, see [Aligning the printer](#).
 - The print head may need to be cleaned. For more information, see [Care and maintenance](#).
-

No page came out of the printer or the paper jammed while printing

Solution

- The printer may need attention. Read the printer screen for instructions.
 - The power may be off or there may be a loose connection. Make sure the power is on and the power cord is securely connected.
 - You may not have any paper in the Main tray or Photo tray. Check that the paper is loaded correctly. For paper-loading instructions, see [Paper loading tips](#).
 - If the paper jammed while printing, try the following:
 - Turn off the printer, then unplug it from the power source. Clear the printer of any paper obstructing the paper path. Remove the rear access door. Gently remove the jammed paper from the printer, then replace the rear access door. If all jammed paper cannot be removed from the rear area of the printer, try removing paper jammed in the middle of the printer by opening the paper jam door located inside the top cover. For illustrations of the two places to clear a paper jam, see [Paper errors](#). When you are finished clearing the paper jam, plug the printer back in, turn it on, and try printing again.
 - If you were printing labels, make sure a label did not become unglued from the label sheet while going through the printer.
-

A blank page came out of the printer

Solution

- You may have begun printing and then cancelled the print job.

If you cancelled the print job before printing started, the printer may have already loaded paper in preparation for printing. The next time you print, the printer ejects the blank page before starting the new printing project.

- A print job with a large amount of data may have been sent to the printer. Wait for the printer to service the print head before it continues printing.
-

The printer asked me to print an alignment page

Solution Periodically, the printer needs to perform a print head alignment to maintain optimal print quality.

When prompted, load plain letter or A4 paper. Discard or recycle the alignment page.

The photo did not print using the default print settings

Solution You may have changed the print settings for the selected photo. Print settings you apply to an individual photo override the default print settings. Discard all print settings that have been applied to an individual photo by deselecting the photo. For more information, see [Settings](#).

The printer ejects the paper when preparing to print

Solution Direct sunlight could be interfering with the operation of the automatic paper sensor. Move the printer out of direct sunlight.

Print quality is poor

Solution

- One of the ink cartridges may be very low on ink, resulting in another color being substituted during printing. Check the estimated ink levels by viewing the ink level icons from the Tools menu (Settings > Tools > Display Ink Gauge). If an ink cartridge is low on ink, replace it. For more information, see [Insert ink cartridges](#).
- Use photo paper designed for the printer. For best results, use the papers recommended in [Choose the right paper](#).
- You may be printing on the wrong side of the paper. Make sure the paper is loaded with the side to be printed facing down.
- You may have selected a low-resolution setting on the digital camera. Reduce the size of the image and try printing again. For better results in the future, set the digital camera to a higher photo resolution.
- There may be a problem with an ink cartridge or with the print head. Try the following:
 - Remove and then reinsert each ink cartridge, one at a time, to make sure they are all properly seated.
 - Run the automatic print head cleaning procedure. For more information, see [Care and maintenance](#).

- Align the printer. For more information, see [Aligning the printer](#).
 - If print quality problems persist after you have tried all of the above solutions, contact HP Support.
-

Photos are not printing correctly

Solution

- You may have loaded the photo paper incorrectly. Load the photo paper with the side to be printed facing down.
 - The photo paper may not have fed into the printer correctly. Try the following:
 - Check for a paper jam. For more information, see [Paper errors](#).
 - Insert the photo paper as far as it will go into the Photo tray.
 - Load one sheet of photo paper at a time.
-

The photos I marked for printing in the digital camera do not print

Solution Some digital cameras let you mark photos for printing in both the camera's internal memory and on the memory card. If you mark photos in the internal memory, and then move photos from the camera's internal memory to the memory card, the marks do not transfer. Mark photos for printing after you transfer them from the digital camera's internal memory to the memory card.

Error messages

Before contacting HP support, read this section for troubleshooting tips or go to the online support services at www.hp.com/support.

Error messages that appear on the printer screen can be divided into the following types:

- [Paper errors](#)
- [Ink cartridge errors](#)
- [Memory card errors](#)
- [Computer printing errors](#)

Paper errors

Before contacting HP support, read this section for troubleshooting tips or go to the online support services at www.hp.com/support.

Error message: Paper jam. Clear jam then press OK.

Solution Turn off the printer, then unplug it from the power source. Clear the printer of any paper that may be obstructing the paper path. Remove the rear access door. Gently remove the jammed paper from the printer, then replace the rear access door.

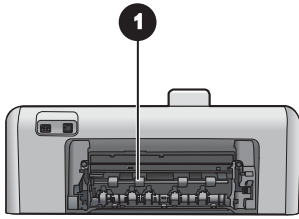

-
- 1 Remove the rear access door to clear paper jams.

If you cannot remove all jammed paper from the rear area of the printer, try removing paper jammed in the middle of the printer by opening the paper jam door located inside the top cover.

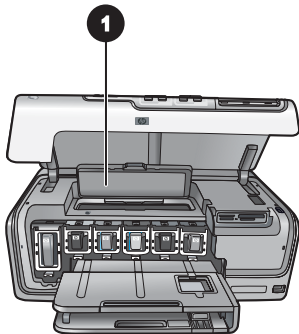

-
- 1 Open the paper jam door to clear paper jams in the middle of the printer.

Plug the printer back in and turn it on.

Error message: Out of paper. Load paper then press OK.

Solution Load paper, then press **OK** to print again. For paper-loading instructions, see [Paper loading tips](#).

Error message: Unsupported media size.

Solution The printer cannot use the size of paper loaded in the paper tray. Press **OK**, then load a supported paper size instead. For a list of supported paper sizes, see [Printer specifications](#).

Error message: Automatic paper sensor failed.

Solution The automatic paper sensor is obstructed or damaged. Try moving the printer out of direct sunlight, then press **OK** and try printing again. If this does not work, go to www.hp.com/support or contact HP Support.

Ink cartridge errors

Before contacting HP support, read this section for troubleshooting tips or go to the online support services at www.hp.com/support.

Error message: Wrong ink cartridge(s) installed

Solution The first time you set up and use your HP Photosmart printer, make sure to install the ink cartridges that were shipped with your printer. The ink in these ink cartridges is specially formulated to mix with the ink in the print head assembly.

To resolve this error, replace the affected ink cartridge(s) with the ink cartridges that were shipped with your HP Photosmart printer.

For more information on replacing ink cartridges, see [Insert ink cartridges](#).

Error message: Incorrect ink cartridge

Solution The indicated ink cartridge(s) cannot be used after the device has undergone initialization. Replace the ink cartridge(s) with the appropriate ink cartridges for your HP Photosmart. The cartridge numbers you can use with this printer appear on the back cover of this printed guide.

For more information on replacing ink cartridges, see [Insert ink cartridges](#).

Error message: Replace cartridges soon

Solution The indicated ink cartridge(s) are empty.

You might be able to continue printing for a short period of time with ink remaining in the print head assembly. Replace the indicated ink cartridge(s) or press **OK** to continue.

For more information on replacing ink cartridges, see [Insert ink cartridges](#).

Error message: Ink cartridge(s) are empty

Solution The indicated ink cartridge(s) are empty and there is not enough ink in the printhead reservoir for normal printing and servicing tasks. Replace the indicated ink cartridge(s) with new ink cartridge(s).

- If the black ink cartridge is empty, you can continue printing with the other color ink cartridges by selecting that option in the displayed printer screen prompts.
- If a color ink cartridge is empty, you can continue printing with the black ink cartridge by selecting that option in the displayed printer screen prompts.

Depending on the status of your print job, you can press **OK** to continue. If the HP Photosmart is in the middle of a print job, press **Cancel** and restart your print job.



Note Text and photo quality will differ from those printed when using all ink cartridges. If the empty ink cartridge(s) are not replaced soon, all printing will stop.

For more information on replacing ink cartridges, see [Insert ink cartridges](#).

Error message: Cannot print

Solution The indicated ink cartridge(s) are out of ink.

Replace the indicated ink cartridge(s) immediately so that you can resume printing.

The HP Photosmart cannot continue printing until the indicated ink cartridge(s) are replaced. All printing will stop.

For more information on replacing ink cartridges, see [Insert ink cartridges](#).

Error message: Ink cartridge problem

Solution The indicated ink cartridge(s) are missing or damaged.

Replace the indicated ink cartridge(s) immediately so that you can resume printing.

If there are no ink cartridges missing from the HP Photosmart, the ink cartridge contacts might need to be cleaned.

For more information on replacing ink cartridges, see [Insert ink cartridges](#). For more information on cleaning the ink cartridge contacts, see [Care and maintenance](#).

If there are no ink cartridges missing from the HP Photosmart, and you still receive this message after cleaning the ink cartridge contacts, you will need a replacement ink cartridge. Remove the affected ink cartridge and look at the end-of-warranty date on the bottom, in YYYY/MMM/DD format. If it is before the end-of-warranty date, contact HP Support to obtain a replacement ink cartridge.

Error message: Ink Expiration Nearly Expired. —OR— Ink Cartridge(s) Expired.

Solution Each ink cartridge has an expiration date. The purpose of expiration is to protect the printing system and to ensure ink quality. When you receive an ink expiration message, remove and replace the ink cartridge, and then close the message. You can also continue printing without replacing the ink cartridge, by following the instructions on your computer screen. HP recommends replacing the expired ink cartridges. HP cannot guarantee the quality or reliability of expired ink cartridges. Device service or repairs required as a result of using expired ink will not be covered under warranty.

For more information on replacing ink cartridges, see [Insert ink cartridges](#).

Error message: Non-HP ink

Solution Replace the indicated ink cartridge(s) or press **OK** to continue.

HP recommends that you use genuine HP ink cartridges. Genuine HP ink cartridges are designed and tested with HP printers to help you easily produce great results, time after time.



Note HP cannot guarantee the quality or reliability of non-HP ink. Printer service or repairs required as a result of printer failure or damage attributable to the use of non-HP ink will not be covered under warranty.

If you believe you purchased genuine HP ink cartridge(s), go to:

www.hp.com/go/anticounterfeit

Error message: Original HP ink depleted

Solution Replace the indicated ink cartridge(s) or press **OK** to continue.

HP recommends that you use genuine HP ink cartridges. Genuine HP ink cartridges are designed and tested with HP printers to help you easily produce great results, time after time.



Note HP cannot guarantee the quality or reliability of non-HP ink. Printer service or repairs required as a result of printer failure or damage attributable to the use of non-HP ink will not be covered under warranty.

If you believe you purchased genuine HP ink cartridge(s), go to:

www.hp.com/go/anticounterfeit

Error message: Scheduled maintenance

Solution You must align the printer to ensure excellent print quality. With letter or A4 unused plain white paper in the Main tray, press **OK**. The HP Photosmart aligns the print head, calibrates the printer, and then prints a test page. Recycle or discard the test page.

Error message: Calibration error

Solution

- If you have color or photo paper loaded in the Main tray when you align the printer, the alignment might fail. Load unused plain white letter or A4 paper into the Main tray, and then try the alignment again. If the alignment fails again, you might have a defective sensor or ink cartridge; contact HP Support.
 - The ink cartridge or sensor is defective. Contact HP support.
-

Error message: Print cartridge cradle is stuck

Solution Remove any objects that are blocking the print head assembly.

To clear the print head assembly

1. Open the top cover, then open the paper jam door.

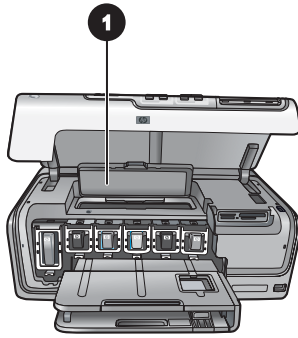

- 1 | Open the paper jam door to clear the print head assembly.
 2. Remove any objects that are blocking the print head assembly, including paper and any packing materials.
 3. Turn the printer off, then turn it on again.
 4. Close the paper jam door and the top cover.
-

Error message: Ink System Failure

Solution The print head assembly or the ink delivery system has failed and the HP Photosmart can no longer print.

Turn off the printer, then unplug its power cord. Wait about 10 seconds, then plug it in again. If this does not clear the error message, please contact HP Support.

Memory card errors

Before contacting HP support, read this section for troubleshooting tips or go to the online support services at www.hp.com/support.

Error message: Photo is missing. —OR— Some photos are missing.

Solution The printer cannot read the file on the memory card, or one or more files specified for the job are missing from the memory card. Try saving the photos to the computer using the digital camera rather than the memory card. If a photo is missing, you may have accidentally deleted the photo from the card.

Error message: Card access error. Job was cancelled. Press OK.—OR— File directory structure is corrupted. —OR— Card may be damaged. Job was cancelled. Press OK.

Solution The printer cannot read the data on the memory card and cannot complete any current print jobs. The data may be corrupted or there may be a physical problem with the memory card.

- Save the files to the computer and access them from there.
 - If this does not work, use a new memory card or reformat the memory card using the digital camera. Any photos on the memory card will be lost.
 - If this does not work, the photo files may be damaged or unreadable. Before you contact HP Support, try another memory card to determine if it is the printer or the memory card that is failing.
-

Error message: Cannot print photos.

Solution More than 10 photos specified for a print job may be corrupted, missing, or are an unsupported file type. For information about supported file types, see [Printer specifications](#).

- Save the photos to the computer using the digital camera rather than the memory card.
 - Save the files to the computer and print from the computer.
 - Print a photo index and reselect photos. For more information, see [Printing photos](#).
-

Error message: Card is password protected. Cannot access card.

Solution The printer cannot read the memory card because the card is password-protected. Follow these steps:

1. Remove the memory card from the printer.
 2. Insert the memory card in the device you originally used to store the password on the memory card.
 3. Remove the password from the memory card.
 4. Remove the memory card and reinsert it in the printer memory card slot.
 5. Try printing again.
-

Error message: Card is locked. Cannot access card.

Solution Make sure the lock switch on the card is in the unlocked position.

Error message: Card is not fully inserted. Push card in a little more.

Solution The printer can detect the memory card but cannot read it. Push the memory card gently into the memory card slot until it stops. For more information, see [Insert memory cards](#).

Error message: Use only one (1) card at a time. Please remove a memory card. —OR— Use only one (1) device at a time. Please remove/disconnect a device.

Solution The printer has two or more different types of memory cards inserted simultaneously, or a memory card is inserted and a digital camera is connected to the camera port at the same time. Remove memory cards or disconnect the camera until only one card is in the printer or only a camera is connected.

Error message: Card was removed. Job was cancelled. Press OK.

Solution You removed a memory card from the printer while it was busy printing a file from the card. Follow these steps:

1. Press **OK**.
2. Reinsert the memory card and print the selected photos again. The memory card must remain inserted until the print job is complete.

To avoid damage to memory cards in the future, do not remove them from the printer memory card slot while they are being accessed. For more information, see [Removing a memory card](#).

Error message: Camera selections (DPOF) file has error.

Solution The printer is unable to read a DPOF file due to corrupted data or an error on the memory card. Use the printer control panel to reselect the photos. For more information, see [Print photos from a memory card](#).

Error message: Some camera-selected photos are not on card.

Solution Some camera-selected photos are missing or have been deleted. Try the following:

- Confirm that you did not accidentally delete the photo from the memory card.
 - Reselect the photos again using the digital camera.
 - Print a new photo index to see the index numbers associated with each photo. For more information, see [Printing photos](#).
-

Error message: Cannot display this photo. —OR— Cannot display all photos. —OR— Photos are corrupted.

Solution The memory card contains image formats the printer does not support, or the files are corrupted. For a list of supported image formats, see [Printer specifications](#). Access photos using the computer. For information about accessing photos through the computer, see [Printing from a computer](#).

Error message: Unsupported card type.

Solution Use your camera to transfer the photos to your computer, and then print from your computer.

Error message: Some photo numbers are not on card.

Solution Use your camera to transfer the photos to your computer, and then print from your computer. If some photos are still missing, they may have been deleted from the memory card.

Computer and connectivity printing errors

Before contacting HP Support, read this section for troubleshooting tips or go to the online support services at www.hp.com/support.

Error message: Printer memory is full. Job was cancelled. Press OK.

Solution The printer encountered a problem when printing photos. Try the following:

- To clear the printer memory, turn the printer off, then turn it on again.
 - Print fewer photos at a time.
 - Save the photos to the computer and print from there.
 - Save the files to the computer using a memory card reader and then print from the computer.
-

Error message: Communication error. Check computer connection. Press OK. —OR— Data was not received. Check computer connection. Press OK to continue. —OR— No response from computer.

Solution The printer cannot communicate properly with the computer. The printer software may not be working or a cable may be loose. Make sure the USB cable is securely attached to both the computer and to the USB port on the back of the printer. If the cable is secure, verify that the printer software is installed.

Error message: Camera disconnected during print job.

Solution The print job will be cancelled. Reattach the USB cable to the camera and printer and resend the print job.

8 HP support

Support process

If you have a problem, follow these steps:

1. Check the documentation that came with the HP Photosmart.
2. Visit the HP online support Web site at www.hp.com/support. HP online support is available to all HP customers. It is the fastest source for up-to-date device information and expert assistance and includes the following features:
 - Fast access to qualified online support specialists
 - Software and driver updates for the HP Photosmart
 - Valuable HP Photosmart and troubleshooting information for common problems
 - Proactive device updates, support alerts, and HP newsletters that are available when you register the HP Photosmart
3. For Europe only: Contact your local point of purchase. If the HP Photosmart has a hardware failure, you will be asked to bring it back to your local point of purchase. (Service is provided at no charge during the device limited warranty period. After the warranty period, you will be quoted a service charge.)
4. Call HP support. Support options and availability vary by device, country/region, and language.

HP support by phone

For a list of support phone numbers, see the phone number list on the inside of the front cover.

Phone support period

One year of phone support is available in North America, Asia Pacific, and Latin America (including Mexico). To determine the duration of phone support in Europe, the Middle East, and Africa, go to www.hp.com/support. Standard phone company charges apply.

Placing a call

Call HP support while you are in front of the computer and the HP Photosmart. Be prepared to provide the following information:

- Device model number (located on the label on the front of the device)
- Device serial number (located on the back or bottom of the device)
- Messages that appear when the situation occurs
- Answers to these questions:
 - Has this situation happened before?
 - Can you re-create it?
 - Did you add any new hardware or software to your computer at about the time that this situation began?
 - Did anything else occur prior to this situation (such as a thunderstorm, device was moved, etc.)?

After the phone support period

After the phone support period, help is available from HP at an additional cost. Help may also be available at the HP online support Web site: www.hp.com/support. Contact your HP dealer or call the support phone number for your country/region to learn more about support options.

A Specifications

This section lists the minimum system requirements for installation of the HP Photosmart software, and provides selected printer specifications.

For a complete list of printer specifications and system requirements, see the onscreen HP Photosmart Printer Help. For information about viewing the onscreen HP Photosmart help, see [Welcome](#).

System requirements

Component	Windows PC minimum	Macintosh minimum
Operating system	Microsoft® Windows 98, 2000 Professional, Me, XP Home, and XP Professional	Mac® OS X 10.3, 10.4, and later
Processor	Intel® Pentium® II (or equivalent) and higher	G3, G4, G5 or Intel Core Duo or greater
RAM	64 MB (128 MB recommended)	Mac OS X 10.3, 10.4, and later: 128 MB
Free disk space	500 MB	150 MB
Video display	800 x 600, 16-bit or higher	800 x 600, 16-bit or higher
CD-ROM drive	4x	4x
Connectivity	USB: Microsoft Windows 98, 2000 Professional, Me, XP Home, and XP Professional PictBridge: using front camera port Bluetooth: using optional HP Bluetooth Wireless Adapter	USB: Front and back ports (Mac OS X 10.3, 10.4, and later) PictBridge: using front camera port Bluetooth: using optional HP Bluetooth Wireless Adapter
Browser	Microsoft Internet Explorer 5.5 or later	—

Printer specifications

Category	Specifications
Connectivity	USB: Microsoft Windows 98, 2000 Professional, Me, XP Home, and XP Professional; Mac OS X 10.3, 10.4, and later
Image file formats	JPEG Baseline TIFF 24-bit RGB uncompressed interleaved TIFF 24-bit YCbCr uncompressed interleaved TIFF 24-bit RGB packbits interleaved

(continued)

Category	Specifications
	TIFF 8-bit gray uncompressed/packbits TIFF 8-bit palette color uncompressed/packbits TIFF 1-bit uncompressed/packbits/1D Huffman
Video file formats	Motion-JPEG AVI Motion-JPEG QuickTime MPEG-1
Media specifications	Recommended maximum length: 61 cm (24 inch) Recommended maximum paper thickness: 292 µm (11.5 mil) Recommended maximum envelope thickness: 673 µm (26.5 mil)
Media sizes supported	Supported sizes when printing from a computer 7.6 x 12.7 cm to 22 x 61 cm (3 x 5 inch to 8.5 x 24 inch) Supported sizes when printing from the control panel Metric: A6, A4, 10 x 15 cm (with and without tab); Imperial: 3.5 x 5 inch, 4 x 6 inch (with and without tab), 4 x 12 inch, 5 x 7 inch, 8 x 10 inch, 8.5 x 11 inch; Other: Hagaki and L-size
Media types supported	Paper (plain, inkjet, photo, and panoramic photo) Envelopes Transparencies Labels Cards: index, greeting, Hagaki, A6, L-size Iron-on transfers Avery C6611 and C6612 photo sticker paper: 10 x 15 cm (4 x 6 inch), 16 rectangular or oval stickers per page
Memory cards	CompactFlash Type I and II Microdrive MultiMediaCard Secure Digital Memory Sticks xD-Picture Card
Memory card-supported file formats	Printing: See Image file formats earlier in this table. Saving: All file formats
Paper tray – media sizes supported	Main tray 8 x 13 cm to 22 x 61 cm (3 x 5 inch to 8.5 x 24 inch) Photo tray Up to 10 x 15 cm (4 x 6 inch), with or without tab Output tray All supported Main tray and Photo tray sizes

(continued)

Category	Specifications
Paper tray capacity	Main tray 100 sheets of plain paper 14 envelopes 20–40 cards (depending on thickness) 30 sheets of labels 25 transparencies, iron-on transfers, or photo paper 10 sheets of photo paper Photo tray Output tray 20 sheets of photo paper 50 sheets of plain paper 10 cards or envelopes 25 sheets of labels or iron-on transfers
Operating environment	Recommended temperature range: 15–30 °C (59–86 °F) Maximum temperature range: 5–40 °C (41–104 °F) Storage temperature range: -40–60 °C (-40–140 °F) Recommended humidity range: 20–80% RH Maximum humidity range: 10–80% RH
Physical specifications	Height: 17.9 cm (6.8 inch). Width: 46.25 cm (18.2 inch) Depth: 38.7 cm (15.25 inch) Weight: 7.7 kg (17.0 lb).
Power consumption	Printing, Average: 75 W Printing, Maximum: 94 W Idle: 13.3–16.6 W
Power supply model number	HP Part # 0957-2105
Power requirement	100–240 VAC (± 10%), 50–60 Hz (± 3 Hz)
Ink cartridges	HP Yellow Ink Cartridge HP Cyan Ink Cartridge HP Light Cyan Ink Cartridge HP Magenta Ink Cartridge HP Light Magenta Ink Cartridge HP Black Ink Cartridge Note The cartridge numbers you can use with this printer appear on the back cover of this printed guide. If you have already used the printer several times, you can also find the cartridge numbers in the printer software. For more information, see Insert ink cartridges .

(continued)

Category	Specifications
Print speed (maximum)	Black printouts: 32 pages per minute Color printouts: 31 pages per minute Photos: 14 seconds for each 10 x 15 cm (4 x 6 inch) photo
USB support	Microsoft Windows 98, 2000 Professional, Me, XP Home, and XP Professional Mac OS X 10.3, 10.4, and later HP recommends using a USB 2.0 full-speed compliant cable 3 meters (10 feet) or less in length.

B HP Warranty

HP product	Duration of limited warranty
Software Media	90 days
Printer	1 year
Print or Ink cartridges	Until the HP ink is depleted or the "end of warranty" date printed on the cartridge has been reached, whichever occurs first. This warranty does not cover HP ink products that have been refilled, remanufactured, refurbished, misused, or tampered with.
Accessories	1 year unless otherwise stated

A. Extent of limited warranty

- Hewlett-Packard (HP) warrants to the end-user customer that the HP products specified above will be free from defects in materials and workmanship for the duration specified above, which duration begins on the date of purchase by the customer.
- For software products, HP's limited warranty applies only to a failure to execute programming instructions, HP does not warrant that the operation of any product will be interrupted or error free.
- HP's limited warranty covers only those defects that arise as a result of normal use of the product, and does not cover any other problems, including those that arise as a result of:
 - Improper maintenance or modification;
 - Software, media, parts, or supplies not provided or supported by HP;
 - Operation outside the product's specifications;
 - Unauthorized modification or misuse.
- For HP printer products, the use of a non-HP cartridge or a refilled cartridge does not affect either the warranty to the customer or any HP support contract with the customer. However, if printer failure or damage is attributable to the use of a non-HP or refilled cartridge or an expired ink cartridge, HP will charge its standard time and materials charges to service the printer for the particular failure or damage.
- If HP receives, during the applicable warranty period, notice of a defect in any product which is covered by HP's warranty, HP shall either repair or replace the product, at HP's option.
- If HP is unable to repair or replace, as applicable, a defective product which is covered by HP's warranty, HP shall, within a reasonable time after being notified of the defect, refund the purchase price for the product.
- HP shall have no obligation to repair, replace, or refund until the customer returns the defective product to HP.
- Any replacement product may be either new or like-new, provided that it has functionality at least equal to that of the product being replaced.
- HP products may contain remanufactured parts, components, or materials equivalent to new in performance.
- HP's Limited Warranty Statement is valid in any country where the covered HP product is distributed by HP. Contracts for additional warranty services, such as on-site service, may be available from any authorized HP service facility in countries where the product is distributed by HP or by an authorized importer.

B. Limitations of warranty

TO THE EXTENT ALLOWED BY LOCAL LAW, NEITHER HP NOR ITS THIRD PARTY SUPPLIERS MAKES ANY OTHER WARRANTY OR CONDITION OF ANY KIND, WHETHER EXPRESS OR IMPLIED WARRANTIES OR CONDITIONS OF MERCHANTABILITY, SATISFACTORY QUALITY, AND FITNESS FOR A PARTICULAR PURPOSE.

C. Limitations of liability

- To the extent allowed by local law, the remedies provided in this Warranty Statement are the customer's sole and exclusive remedies.
- TO THE EXTENT ALLOWED BY LOCAL LAW, EXCEPT FOR THE OBLIGATIONS SPECIFICALLY SET FORTH IN THIS WARRANTY STATEMENT, IN NO EVENT SHALL HP OR ITS THIRD PARTY SUPPLIERS BE LIABLE FOR DIRECT, INDIRECT, SPECIAL, INCIDENTAL, OR CONSEQUENTIAL DAMAGES, WHETHER BASED ON CONTRACT, TORT, OR ANY OTHER LEGAL THEORY AND WHETHER ADVISED OF THE POSSIBILITY OF SUCH DAMAGES.

D. Local law

- This Warranty Statement gives the customer specific legal rights. The customer may also have other rights which vary from state to state in the United States, from province to province in Canada, and from country to country elsewhere in the world.
- To the extent that this Warranty Statement is inconsistent with local law, this Warranty Statement shall be deemed modified to be consistent with such local law. Under such local law, certain disclaimers and limitations of this Warranty Statement may not apply to the customer. For example, some states in the United States, as well as some governments outside the United States (including provinces in Canada), may:
 - Preclude the disclaimers and limitations in this Warranty Statement from limiting the statutory rights of a consumer (e.g., the United Kingdom);
 - Otherwise restrict the ability of a manufacturer to enforce such disclaimers or limitations; or
 - Grant the customer additional warranty rights, specify the duration of implied warranties which the manufacturer cannot disclaim, or allow limitations on the duration of implied warranties.
- THE TERMS IN THIS WARRANTY STATEMENT, EXCEPT TO THE EXTENT LAWFULLY PERMITTED, DO NOT EXCLUDE, RESTRICT, OR MODIFY, AND ARE IN ADDITION TO, THE MANDATORY STATUTORY RIGHTS APPLICABLE TO THE SALE OF THE HP PRODUCTS TO SUCH CUSTOMERS.

HP Limited Warranty

Dear Customer,

You will find below the name and address of the HP entity responsible for the performance of the HP Limited Warranty in your country.

You may have additional statutory rights against the seller based on your purchase agreement. Those rights are not in any way affected by this HP Limited Warranty.

Ireland: Hewlett-Packard Ireland Ltd, 30 Herbert Street IRL-Dublin 2

United Kingdom: Hewlett-Packard Ltd, Cain Road, Bracknell, GB-Berks RG12 1HN

Index

A

- accessories 9
- accessories, two-sided printing 9
- after the support period 58
- aligning the printer 37
- alignment page 37
- alignment, required 52
- antique coloration 27

B

- Bluetooth
 - connecting to printer 21, 29
 - menu settings 9
 - wireless printer adapter 9
- borderless prints 27
- buttons 8

C

- calling HP support 57
- cameras
 - connecting to printer 21, 29
 - direct-printing 23
 - PictBridge 23
 - port 6
 - printing from 23
- care and maintenance 37
- cartridges. *See* ink cartridges
- cleaning
 - copper-colored contacts 38
 - print head 38
 - printer 37
- color effects 27
- CompactFlash 18
- computer
 - connecting to printer 29
 - printing from 33
 - saving photos to 31
 - system requirements 59
- control panel 8

D

- damaged, ink cartridge 51
- date and time stamps 27

- digital cameras. *See* cameras
- Digital Print Order Format 22
- documentation, printer 5
- DPOF 22

E

- e-mailing photos 31
- energy consumption 4
- Energy Star 4
- error messages 48

F

- file formats, supported 18, 59
- Frequently asked questions 43

G

- Getting help 43

H

- Help 43
- Hewlett-Packard Company notices 4
- home, screen 9
- HP direct-printing digital cameras 23
- HP Instant Share 29
- HP Photosmart Essential 33
- HP Photosmart Premier 33
- HP Photosmart Share 31, 34
- HP Photosmart Studio (Mac only) 34
- HP Software Update 40

I

- ink
 - checking level 39
 - empty 50
 - replace soon 50
- ink cartridges
 - damaged 51
 - empty 50
 - expired 51
 - HP ink depleted 52
 - incorrect 50
 - ink level, checking 17
 - inserting 17

- missing 51
- non-HP ink 51
- printer alignment 52
- replace soon 50
- replacing 17
- storing 41
- testing 39
- ink level, checking 17
- inserting
 - ink cartridges 17
 - memory cards 19
- iPod 30

J

- JPEG file formats 18

L

- layout and photo size 24
- lights 8
- Load paper 13

M

- Macintosh
 - HP Photosmart Mac software 34
- memory cards
 - inserting 19
 - printing from 21
 - removing 20
 - saving photos to a computer 31
 - supported types 18
- Memory Sticks 18
- Microdrive 18
- missing ink cartridge 51
- MPEG-1 file format 18
- MultiMediaCard 18

P

- Paper
 - load 13
- paper
 - buying and choosing 13
 - maintaining 13, 41
 - specifications 59
 - trays 6

- phone support 57
- phone support period
 - period for support 57
- photos
 - antique coloration 27
 - cropping 27
 - date and time stamp 27
 - e-mailing 31
 - framing 27
 - improving quality 26
 - printing 21
 - saving to computer 29
 - sepia tones 27
 - supported file formats 18
 - zooming 27
- Photosmart Share. *See*
 - HP Photosmart Share
- PictBridge cameras 23
- placing a call 57
- print head
 - cleaning 38
 - failure 53
 - stalled 52
- print quality
 - changing 21
- Printer
 - Specifications 59
- printer
 - accessories 9
 - care and maintenance 37
 - cleaning 37
 - connecting 21, 29
 - documentation 5
 - error messages 48
 - home 9
 - parts 6
 - specifications 59
 - storing 41
- printer software
 - updating 40
- printer software, updating 33
- printing
 - from a computer 33
 - from BlueTooth device 21
 - from cameras 23
 - from memory cards 21
 - from PictBridge camera 21
 - photos 21
 - range of photos 21
 - test page 39
 - without computer 21
- Q**
- quality
 - photo paper 41
 - photos 26
 - printing test page 39
- Questions and Answers 43
- R**
- range
 - printing 21
- regulatory notices
 - regulatory model
 - identification number 4
- removing memory cards 20
- replacing ink cartridges 17
- S**
- saving photos to computer 29
- Secure Digital 18
- sepia tones 27
- Sony Memory Sticks. *See*
 - Memory Sticks
- Specifications 59
- storing
 - ink cartridges 41
 - photo paper 41
 - printer 41
- support 57
- support process 57
- system requirements 59
- T**
- test page 39
- TIFF file format 18
- transporting printer 9
- trays, paper 6
- Troubleshooting 43
- troubleshooting
 - error messages 48
- two-sided printing 9
- U**
- USB
 - connection type 29
 - port 6
 - specifications 59
- V**
- video clip
 - supported file formats 18
- X**
- xD-Picture Card 18



Print Cartridge Selection Numbers



Black	02
Yellow	02
Light Cyan	02
Cyan	02
Light Magenta	02
Magenta	02

© 2006 Hewlett-Packard Development Company, L.P.

Printed in [country] - English

www.hp.com



EN



Q7046-90227