

**Invacare[®] Pronto[™] M41 Series
with SureStep[®]
SERVICE MANUAL**

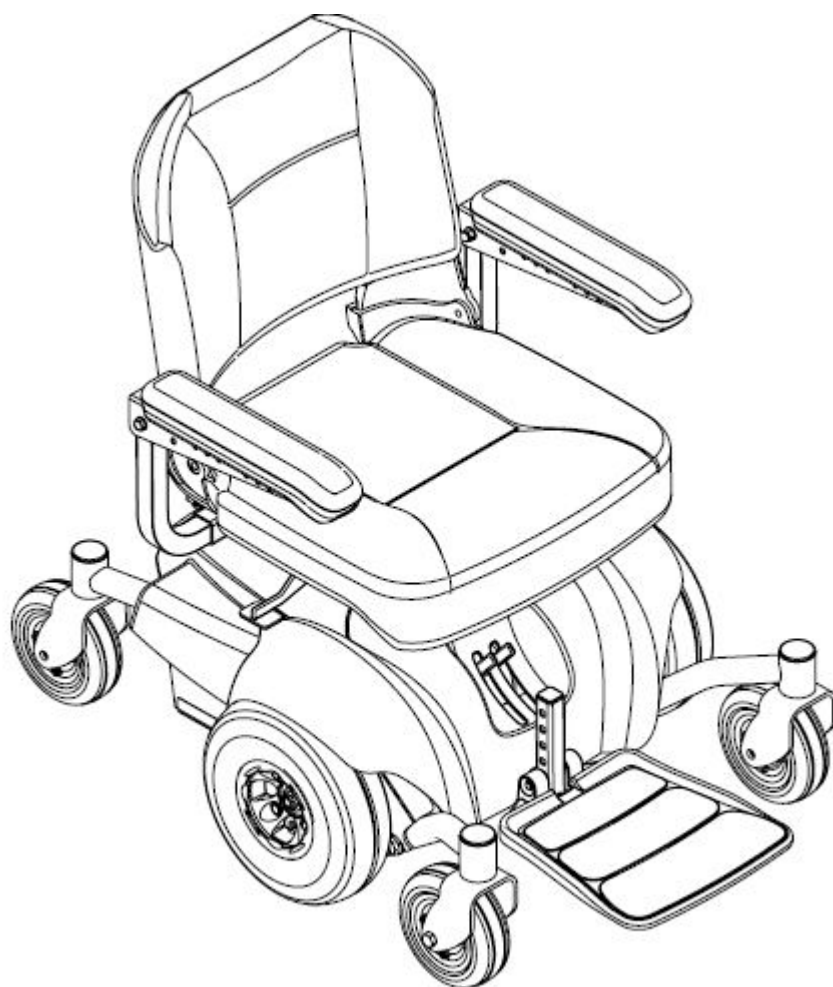

DEALER: Keep this manual.

The procedures in this manual MUST be performed by a qualified technician.



Edition: 1568396A Vers. 002 - 22.01.2015



This manual is part of the instructions for use.

© 2014 Invacare[®] Corporation

All rights reserved. Republication, duplication or modification in whole or in part is prohibited without prior written permission from Invacare. Trademarks are identified by TM and [®]. All trademarks are owned by or licensed to Invacare Corporation or its subsidiaries unless otherwise noted.

Contents

Chapter		Page
1	Introduction	6
1.1	General information	6
1.2	Notes on transport	6
1.3	Definition and representation of information and safety information in this manual	7
1.4	Hazard symbols and symbols used.....	8
1.5	Images in this manual	9
2	Safety and fitting instructions	10
2.1	Power module settings / Repair or service	10
2.2	Operation information.....	10
2.3	Before any inspection or repair work	11
2.4	Personal safety equipment.....	11
2.5	General safety information and information about fitting / removal	11
3	Tightening torques	13
4	Arrangement of sub-assemblies and components	14
4.1	Overview.....	14
4.2	Overview of the electronic modules (ACS2 system).....	15
4.2.1	ACS2 DX2-PMA70 electronic module	17
4.2.2	ACT2 actuator module.....	17
4.2.3	ACT4 actuator module.....	17
4.2.4	Shark MK5NX electronics module.....	18
5	Service plan	19
6	Operational faults	22
6.1	Troubleshooting	22
6.1.1	Service Indicator Diagnostics (Shark 2/MK5 SPJ+).....	23
6.1.2	Service Indicator Diagnostics (ACS2).....	26
6.1.3	Motor/Gearbox/Brake	27
6.1.4	Battery.....	29
6.1.5	Battery Charger.....	30
7	Initial test procedures	31
7.1	Testing the motor	31
7.2	Testing the electro-mechanical parking brake	32
7.3	Rain test.....	33
7.4	Field load test.....	33
7.5	Checking battery charge level.....	34
7.6	Checking an actuator	35
8	Repair work	36
8.1	Covers and frame	36
8.1.1	Removing/Installing the top cover.....	36
8.1.2	Removing/Installing the front cover	37
8.1.3	Removing/Installing the rear cover	38
8.1.4	Removing/Installing the swingarm assembly	39
8.1.5	Removing/Installing the spring.....	40
8.2	Electronics	41
8.2.1	Removing/Installing the joystick (office style seat)	41
8.2.2	Repositioning the joystick mounting bracket (office style seat)	42
8.2.3	Disconnecting/Connecting the joystick	43
8.2.4	Replacing the ACS2 power module.....	44

8.2.5	Replacing the actuator module	46
8.2.6	Replacing the Shark power module	48
8.3	Updating the driving program	49
8.4	Wheels	50
8.4.1	Engaging/Disengaging motor release lever	50
8.4.2	Removing/Installing the front/rear casters	50
8.4.3	Adjusting forks	51
8.4.4	Removing/Installing forks and/or caster assemblies	52
8.5	Drive wheels.....	53
8.5.1	Removing/Installing the drive wheel	53
8.6	Drive unit	54
8.6.1	Removing/Installing the motor	54
8.7	Batteries	56
8.7.1	Warnings for handling and replacing batteries	56
8.7.2	Using the proper batteries.....	57
8.7.3	Removing/Installing batteries.....	58
8.7.4	Connecting/Disconnecting battery cables.....	60
8.7.4.1	Connecting battery cables	60
8.7.4.2	Disconnecting battery cables.....	62
8.7.5	Correct handling of damaged batteries.....	63
8.8	Cables	64
8.8.1	Cable routing.....	64
8.8.2	Checking the cables	65
8.9	Seat system.....	66
8.9.1	Captain's seat/standard seat	66
8.9.1.1	Removing/Installing the seat assembly	66
8.9.2	Modulite Seat.....	67
8.9.2.1	Moving the seat into the service position.....	67
8.9.2.2	Replacing the seat angle adjustment actuator	69
8.9.2.3	Replacing the lifter actuator	70
8.9.2.4	Replacing the lifter / seat angle adjustment module.....	71
8.9.2.5	Replacing the backrest actuator	74
8.9.2.6	Replacing the seat support (without lifter or seat angle adjustment modules)	75
8.9.3	Backrest unit - Modulite	78
8.9.3.1	Replacing the standard backrest	78
8.9.3.2	Replacing the backrest mounting bracket	79
8.10	Adjusting the seat width/ backrest width (Modulite)	80
8.10.1	Adjusting the seat width	80
8.10.2	Adjusting the backrest width	82
8.10.3	Adjusting the Flex3 backrest.....	84
8.11	Backrest unit - Standard	85
8.11.1	Adjusting sling backrest (standard seat).....	85
8.11.2	Replacing the standard backrest	86
8.12	Armrest	87
8.12.1	Removing/Installing Armrest (Captain's seat).....	87
8.12.2	Replacing the armrest assembly (Captain's seat)	88
8.12.3	Removing/Installing Armrest (Modulite seat)	89
8.12.4	Replacing the armrest (Modulite seat).....	90
8.13	Footboard.....	91
8.13.1	Removing/Installing the footboard assembly	91
9	Accessoires	92
9.1	Replacing the postural belt	92
9.1.1	Replacing the postural belt (Captain's seat)	92
9.1.2	Replacing the postural belt (standard seat)	93
9.1.3	Replacing postural belts (Modulite seat).....	94
9.1.3.1	Installation on the backrest mounting bracket (simple backrest).....	94
9.1.3.2	Installation on the backrest mounting bracket (adjustable seat)	95
9.1.3.3	Installation on the seat frame profile (adjustable seat)	96
9.2	Further accessoires.....	97

10	Adjusting the seating position	98
10.1	Adjusting the lower leg length and seat depth	99
10.1.1	Adjusting the lower leg length	99
10.1.2	Adjusting the seat depth	99
10.1.2.1	Captain's seat	99
10.1.2.2	Standard seat	103
10.1.2.3	Modulite seat	104
10.2	Adjusting the seat height and seat angle	105
10.2.1	Adjusting the seat height (Captain's seat and standard seat).....	105
10.2.2	Adjusting the seat height (Modulite seat).....	106
10.2.3	Adjusting the seat angle (Modulite seat).....	107
10.3	Adjusting the center of gravity of the seat	108
10.3.1	Captain's seat and standard seat	109
10.3.2	Modulite seat.....	109
11	Final check	110

1 Introduction

These instructions contain information about:

Testing work

Repair Instructions

1.1 General information

- Service and maintenance work must be carried out taking this service manual into account.
- It is imperative that you observe safety information.
- Information about operation or about general maintenance and care work on the mobility aid should be taken from the user manual.
- You can find information about ordering spare parts in the spare parts catalogue.
- Only use original Invacare® spare parts. The guarantee will become invalid if other spare parts are used!
- We reserve the right to make any alterations on the grounds of technical improvements.
- The mobility aid may only be maintained and overhauled by qualified personnel.
- The minimum requirement for service technicians is suitable training, such as in the cycle or orthopaedic mechanics fields, or sufficiently long-term job experience.
 - Experience in the use of electrical measuring equipment (multimeters) is also a requirement.
 - Special Invacare® training is recommended.
- Alterations to the mobility aid which occur as a result of incorrectly or improperly executed maintenance or overhaul work lead to the exclusion of all liability on the side of INVACARE.
- If you have any problems or questions please contact Invacare® Service.

1.2 Notes on transport

- If the mobility aid has to be shipped back to the manufacturer for major repairs, you should always use the original packaging for transport.
- Please attach a precise description of the fault.

1.3 Definition and representation of information and safety information in this manual

Different types of information and signal words are used throughout this manual.



DANGER!

The signal word "DANGER" refers to immediate hazards.

- *The following lines in italics refer to actions which serve to avoid such hazards.*



WARNING!

The signal word "WARNING!" refers to possibly-occurring hazards which can lead to death or serious injuries if they are not avoided.

- *The following lines in italics refer to actions which serve to avoid such hazards.*



CAUTION!

The signal word "CAUTION" refers to possibly-occurring hazards which can lead to minor injuries and/or material damage if they are not avoided.

- *The following lines in italics refer to actions which serve to avoid such hazards.*



IMPORTANT!

The signal word "IMPORTANT" refers to hazards which could lead to material damage if they are not avoided.

- *The following lines in italics refer to actions which serve to avoid such hazards.*



Note

The signal word "Note" is used to denote general information which simplifies the handling of your product and refers to special functions.

1.4 Hazard symbols and symbols used

Different types of hazard symbols and symbols are used throughout this manual.



General hazards

This symbol warns you of general hazards!

- Always follow the instructions to avoid injury to the user or damage to the product!



BURN DANGER!

This symbol warns you of the danger of chemical burns, for example due to the discharge of battery acids!

- Always follow the instructions to avoid injury to the user or damage to the product!



RISK OF CRUSHING!

This symbol warns you of crushing hazards due to inattentive working with heavy components.

- Always follow the instructions to avoid injury to the user or damage to the product!



EXPLOSION DANGER!

This symbol warns you of an explosion hazard, which can be caused by excessive tyre pressure in a pneumatic tyre.

- Always follow the instructions to avoid injury to the user or damage to the product!



Wear safety shoes

The symbol refers to the requirement for wearing safety shoes.

- Wear standardised safety shoes during all work.



Wear eye protection

This symbol refers to the requirement for wearing eye protection, for example when working with batteries.

- Wear eye protection when this symbol is shown.



Wear safety gloves

This symbol refers to the requirement for wearing safety gloves, for example when working with batteries.

- Wear safety gloves when this symbol is shown.



Note

This symbol identifies general information which is intended to simplify working with your product and which refers to special functions.



Always dispose used or damaged batteries correctly

The symbol refers to information for the correct disposal of used or damaged batteries.

1.5 Images in this manual

The detailed images in this manual are given digits to identify various components. Component numbers in text and operational instructions always relate to the image directly above.

2 Safety and fitting instructions

These safety instructions are intended to prevent accidents at work, and it is imperative that they are observed.



WARNING!

This section contains important information for the safe operation and use of this product. Do not use this product or any available optional equipment without first completely reading and understanding these instructions and any additional instructional material such as User Manuals, Service Manuals or Instruction Sheets supplied with this product or optional equipment. If you are unable to understand the Warnings, Cautions or Instructions, contact a healthcare professional, dealer or technical personnel before attempting to use this equipment - otherwise, injury or damage may occur.

2.1 Power module settings / Repair or service

- Set-up of the Electronic Control Unit is to be performed only by a qualified technician. The final adjustments of the power module may affect other activities of the wheelchair. Personal injury or damage to the equipment could occur if improperly set-up or adjusted.
- Wheelchairs should be examined during maintenance for signs of corrosion (by, for example, liquid exposure). Electrical components damaged by corrosion should be replaced IMMEDIATELY.
- Wheelchairs that are frequently exposed to liquids may require replacement of electrical components more frequently.

2.2 Operation information

- Performance adjustments should only be made by professionals of the healthcare field or persons fully conversant with this process and the driver's capabilities. Incorrect settings could cause injury to the driver, bystanders, damage to the chair and to surrounding property.
- After the wheelchair has been set-up, check to make sure that the wheelchair performs to the specifications entered during the set-up procedure. If the wheelchair does not perform to specifications, turn the wheelchair Off IMMEDIATELY and reenter set-up specifications. Repeat this procedure until the wheelchair performs to specifications.
- DO NOT engage or disengage the motor release levers until the power is in the OFF position.
- Before performing any maintenance, adjustment or service verify that On/Off switch on the joystick is in the off position.
- Avoid storing or using the wheelchair near open flame or combustible products. Serious injury or damage to property may result.
- ALWAYS keep hands and fingers clear of moving parts to avoid injury.
- NEVER leave an unoccupied wheelchair on an incline.
- DO NOT attempt to lift the wheelchair by any removable (detachable) parts. Lifting by means of any removable (detachable) parts of the wheelchair may result in injury to the user or damage to the wheelchair.
- Make sure the detent balls of the quick-release pin of the footboard are fully released beyond the outer edge of the tube before returning the wheelchair to the user. Otherwise, injury and/or damage may result.
- Keep detent balls clean.

2.3 Before any inspection or repair work

- Read and observe this service manual and the associated user manual!
- Observe the minimum requirements for carrying out the work (see chapter entitled „General information)!

2.4 Personal safety equipment



Safety shoes

The mobility device, and some of its components, are very heavy. These parts can result in injuries to the feet if they are allowed to drop.

- *Wear standardised safety shoes during all work.*



Eye protection

It is possible that battery acid can be discharged when working on defective batteries or when handling batteries improperly.

- *Always wear eye protection when working on any defective or possibly defective batteries.*



Safety gloves

It is possible that battery acid can be discharged when working on defective batteries or when handling batteries improperly.

- *Always wear acid-proof safety gloves when working on any defective or possibly defective batteries.*

2.5 General safety information and information about fitting / removal



WARNING! Risk of crushing!

Various components such as the drive unit, batteries, seat etc are very heavy. This results in injury hazards to your hands!

- *Please note the high weight of some components! This applies especially to the removal of drive units, batteries and the seat.*



WARNING!

Injury hazard if the vehicle starts moving unintentionally during repair work!

- *Switch the power supply off (ON/OFF key)!*
- *Engage the drive!*
- *Before raising the vehicle, secure the wheels by blocking them with wedges!*



CAUTION!

Fire and burn hazard due to electrical short-circuit!

- *The mobility device must be completely switched off before removal of voltage-carrying components! To do this, remove the batteries.*
- *Avoid short-circuiting the contacts when carrying out measurements on voltage-carrying components!*



IMPORTANT!

Risk of burns from hot surfaces on the motor!

- *Allow the motors to cool down before commencing work on them.*

**CAUTION!****Injury hazard and Risk of damage to vehicle due to improper or incomplete maintenance work!**

- Use only undamaged tools in good condition.
- Some moving parts are mounted in sockets with PTFE coating (Teflon™). Never grease these sockets!
- Never replace self-locking nuts with "normal" nuts.
- Always use correctly-dimensioned washers and spacers.
- When reassembling, always replace any cable ties which were cut during dismantling.
- After completing your work / before renewed start-up of the mobility device, check all connections for tight fitting.
- After completing your work / before renewed start-up of the mobility device, check all parts for correct locking.
- Only operate the vehicle with the approved tyre pressures (see technical data).
- Check all electrical components for correct function. Please note that incorrect polarity can result in damage to the electronics.
- Always carry out a trial run at the end of your work.

**IMPORTANT!****Risk of injury and damage to property, if the maximum speed reduction on a wheelchair with a lifter does not function correctly!**

The wheelchair's control unit must reduce the maximum possible speed as soon as the lifter is raised.

- Test the maximum speed reduction for correct function after any maintenance work or modifications to the wheelchair.

**Note**

Mark all current settings for the mobility aid (seat, armrests, backrest etc.), and the associated cable connecting plugs, before dismantling. This makes reassembly easier.

All plugs are fitted with mechanical safety devices which prevent release of the connecting plugs during operation. To release the connecting plugs the safety devices must be pressed in. When reassembling ensure that these safety devices are correctly engaged.

**WARNING!****Any changes to the drive program can affect the driving characteristics and the tipping stability of the vehicle!**

- Changes to the drive program may only be carried out by trained Invacare® specialist dealers!
- Invacare® supplies all mobility aids with a standard drive program ex-works. Invacare® can only give a warranty for safe vehicle driving behaviour - especially tipping stability - for this standard drive program!

3 Tightening torques

The tightening torques stated in the following list are based on the thread diameter for the nuts and bolts for which no specific values have been determined. All values assume dry and de-greased threads.



IMPORTANT!

Damage can be caused to the mobility device due to improperly tightened screws, nuts or plastic connections.

- *Always tighten screws, nuts etc to the stated tightening torque.*
- *Only tighten screws or nuts which are not listed here fingertight.*

Thread	M4	M5	M6	M8	M10	M12	M14	M16
Tightening torque in Nm $\pm 10\%$	3 Nm	6 Nm	10 Nm	25 Nm	49 Nm	80 Nm	120 Nm	180 Nm

UNC Thread	Tightening torque in Nm
1/4"-20	11-7 Nm
5/16"-20	22-14 Nm
3/8"-16	41-25 Nm
7/16"-14	67-40 Nm
1/2"-13	100-60 Nm
9/16"-12	150-90 Nm
5/8"-11	210-130 Nm
3/4"-1	370-230 Nm
7/6"-9	600-370 Nm
1"-8	900-550 Nm

4 Arrangement of sub-assemblies and components

4.1 Overview

Under the rear cover/seat:

Depending on the seat variant:

- (1) – Electronic module
- (2) – Actuator module (optional)

The electronic modules that are installed are described in chapter 4.2.

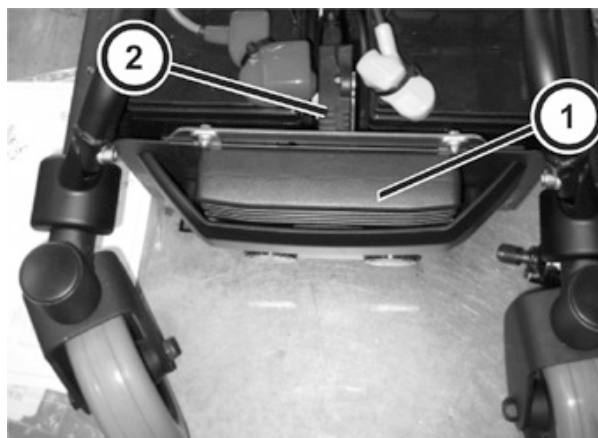

Under the seat:

Depending on the seat variant:

- (1) – Seat angle adjustment actuator module (optional)
- (2) – Lifter actuator module (optional)

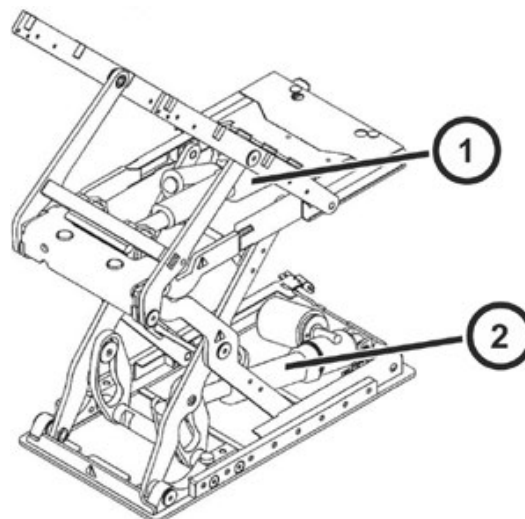

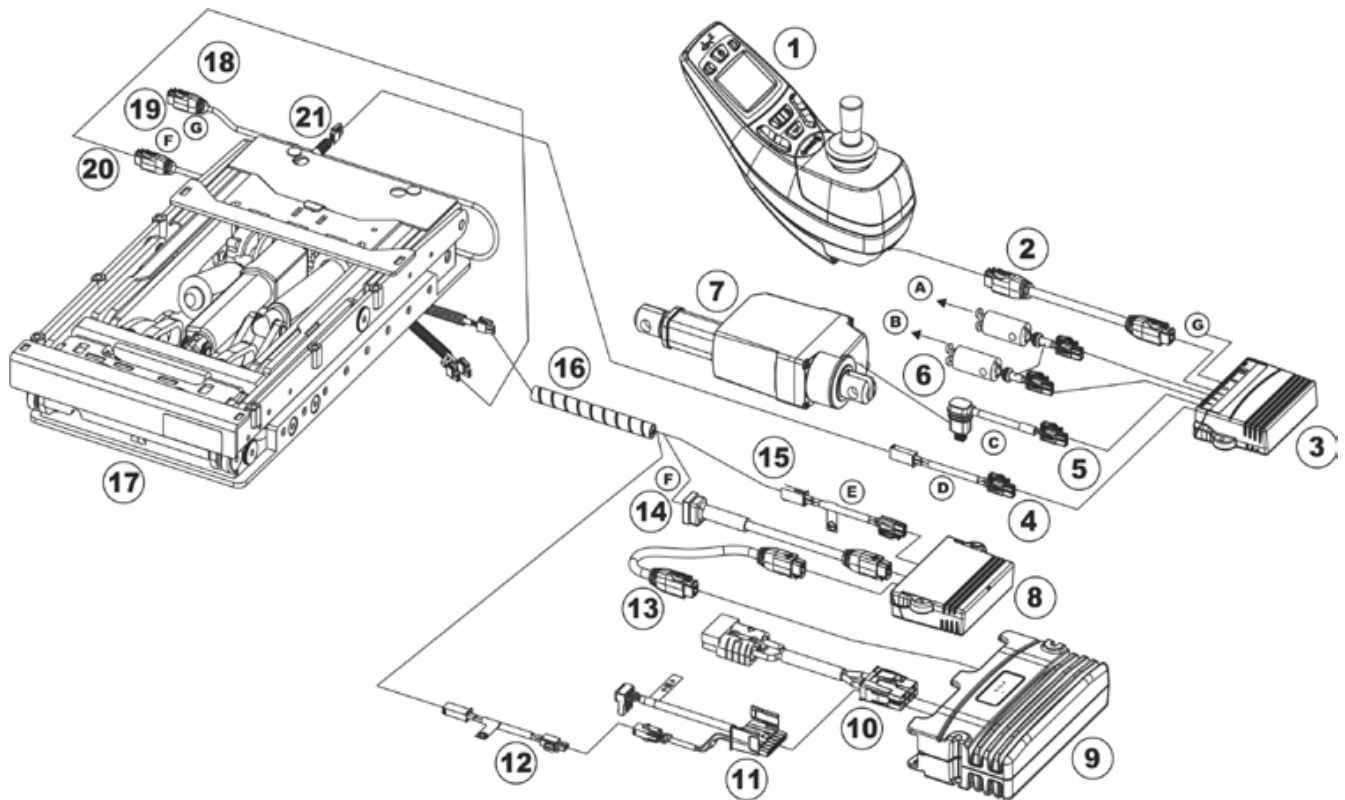

4.2 Overview of the electronic modules (ACS2 system)

Various different types of electronic modules can be installed in the wheelchair.

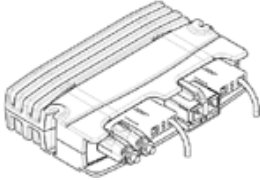
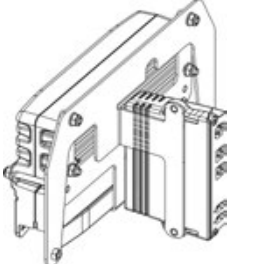
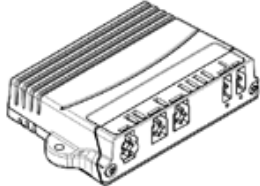

- | | | | | | |
|---|----------------------------|----|-------------------------------------|----|------------------------------------|
| 1 | Remote | 10 | Battery cable | 19 | ACT4 bus |
| 2 | ASC bus cable | 11 | Light cable | 20 | ACT2 bus |
| 3 | Actuator module ACT4 | 12 | Extension cable | 21 | Seat angle adjustment |
| 4 | Adapter cable | 13 | ACS bus cable | A | Legrest RH to channel 4 |
| 5 | ACS harness | 14 | ACS extension cable | B | Legrest LH to channel 3 |
| 6 | Power supply legrests | 15 | ACT adapter cable | C | Recliner to channel 2 |
| 7 | Actuator module (backrest) | 16 | Spiral wrap black | D | Seat angle adjustment to channel 1 |
| 8 | Actuator module ACT2 | 17 | Lifter/seat angle adjustment module | E | Lifter to channel 1 |
| 9 | Power module | 18 | ACS bus cable | F | Bus A1 |
| | | | | G | Bus A2 |

Before you connect components of the wheelchair such as adjustment motors or actuators to the electronic module, make sure you know exactly which electronic module is installed. The following table provides an overview.

Electronic modules	Designations	Remotes	Remarks
	ACS2 DX2-PMA70	G90A REM A REM 24 SD REM 34 REM 41 REM 550 G91S	
	ACS2 with actuator module ACT		The actuator module is optional.
	Actuator module ACT2 ACT4		The actuator module is optional.
	Shark MK5NX (40 Amp)	Shark 2/MK5 SPJ+	

4.2.1 ACS2 DX2-PMA70 electronic module

Connections

- 1) Battery 24V
- 2) Bus cable (to remote or ACT)
- 3) Bus cable (to remote or ACT)
- 4) Motor M1
- 5) Light
- 6) Motor M2

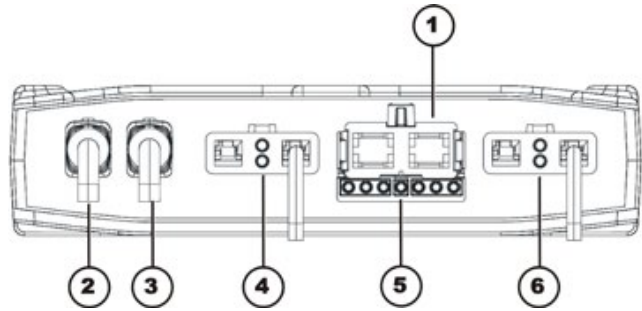

Rubber stoppers for free slots

- 2) & 3) Order number: 1552876

4.2.2 ACT2 actuator module

Various types of adjustment motors, also called actuators, can be installed on the wheelchair. These actuators are either connected directly to the electronic module or to a separate actuator module. The actuator module is connected to the electronic module via a bus cable.

Connections

- 1) ACI*
- 2) Bus cable (to remote or ACT)
- 3) Bus cable (to remote or ACT)
- 4) Adjustment motor/actuator - channel 2
- 5) Adjustment motor/actuator - channel 1

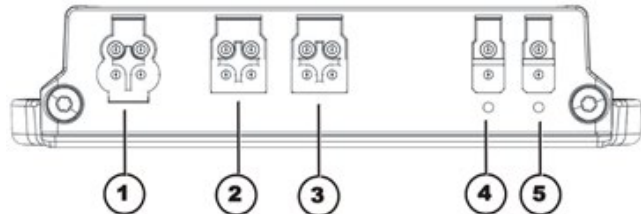

Rubber stoppers for free slots

- 1) Order number: 1555701
- 2) & 3) Order number: 1552876
- 4) & 5) Order number: 1555700

* The ACI connection serves to limit the movement of an actuator or to reduce velocity.

4.2.3 ACT4 actuator module

Connections

- 1) ACI*
- 2) Bus cable (ACT or power module)
- 3) Bus cable (ACT or power module)
- 4) Actuator - Channel 4
- 5) Actuator - Channel 3
- 6) Actuator - Channel 2
- 7) Actuator - Channel 1

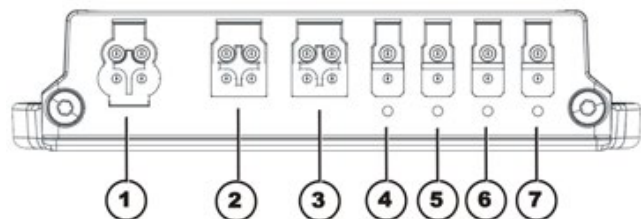

Rubber stoppers for free slots

- 1) Order number: 1555701
- 2) & 3) Order number: 1552876
- 4) to 7) Order number: 1555700

* The ACI connection is used for actuator limitation or speed reduction.

4.2.4 Shark MK5NX electronics module

Connections

- 1) Joystick box
- 2) Left-hand motor
- 3) Battery
- 4) Right-hand motor

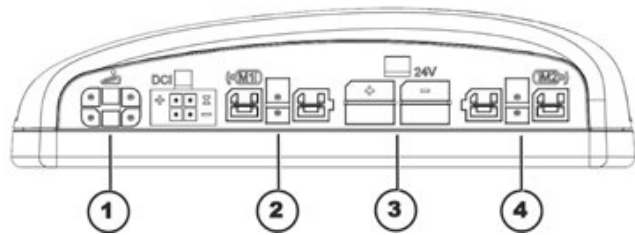

5 Service plan

These adjustments should be made whenever this product is serviced, but at least once a year. They should especially be done as part of the initial unit setup. Follow these procedures:



IMPORTANT!

Risk of injury and damage to property, if the maximum speed reduction on a wheelchair with a lifter does not function correctly!

The wheelchair's control unit must reduce the maximum possible speed as soon as the lifter is raised.

- *Test the maximum speed reduction for correct function after any maintenance work or modifications to the wheelchair.*

Component	Check	Remedy	Notes	✓
Postural belt	• Damage to postural belt	• Replace if necessary.	See chapter 9.1	
	• Belt lock function	• Replace if necessary.	See chapter 9.1	
Upholstery	• Check for damage and wear.	• Replace if necessary.		
Armrests	• Damage to armrests	• Replace if necessary.		
	• Armrest fixings	• Tighten screws		
Side panels	• Damage to side panels	• Replace if necessary.		
	• Side panel fixings	• Tighten screws		
Seat	• Secure fit to wheelchair frame	• Tighten screws.		
Seat lock	• Seat lock defective	• Replace seat lock		
Seat angle adjustment	• Tight seating of SL retainer clip	• Replace SL retainer clip if necessary		
Seat release latch (if fitted)	• Damage and wear • Check function.	• Replace if necessary.		
Power backrest (if fitted)	• Damage to backrest • Seams • Fixing • Check cable. • Check function.	• Replace parts if necessary. • Tighten screws. • Replace cable or motor if necessary.		

Component	Check	Remedy	Notes	✓
Frames (chassis) / battery mounting	<ul style="list-style-type: none"> Check fixings, welded seams and battery mounting. 	<ul style="list-style-type: none"> Tighten screws. Replace components if necessary. 		
Wheel suspension and wheels	<ul style="list-style-type: none"> Check drive wheels for tight fit and side play. 	<ul style="list-style-type: none"> Adjust, replace wheel hubs. 	See chapter 8.5	
	<ul style="list-style-type: none"> Check casters for tight fit, float and side play. 	<ul style="list-style-type: none"> Replace wheels, wheel fork or wheel bearings. Loosen/tighten locknut if necessary. 	See chapter 8.4	
	<ul style="list-style-type: none"> Check casters for debris. 	<ul style="list-style-type: none"> Clean if necessary. 		
	<ul style="list-style-type: none"> Check straight running. 	<ul style="list-style-type: none"> Replace wheels, wheel fork or wheel bearing. 	See chapter 8.4.4	
Puncture-proof tires	<ul style="list-style-type: none"> Check for flat spots and wear. 	<ul style="list-style-type: none"> Replace if necessary. 		
Drive units, coupling mechanism	<ul style="list-style-type: none"> Check functions in drive and push modes. Check coupling mechanism. 	<ul style="list-style-type: none"> Replace motor if necessary. Tighten screws/nuts, adjust or replace if necessary 	See chapter 8.6.1	
Legrests (Footboard)	<ul style="list-style-type: none"> Check welded seams, interlocking, screws and footboard. 	<ul style="list-style-type: none"> Tighten, replace if necessary. 	See chapter 8.13 or user manual.	
Power legrests (if fitted)	<ul style="list-style-type: none"> Check cable. Check contacts. Check functions. 	<ul style="list-style-type: none"> Replace cable if necessary. 		
Electrical components	<ul style="list-style-type: none"> Check for corrosion. 	<ul style="list-style-type: none"> Replace if corroded or damaged. 	See chapter 8.2.	
Batteries	<ul style="list-style-type: none"> Check batteries for damage. 	<ul style="list-style-type: none"> Replace if necessary. 	Please refer to the safety information in chapter 8.7 for handling batteries	
	<ul style="list-style-type: none"> Check battery voltage. 	<ul style="list-style-type: none"> Charge batteries. 	See user manual	

Component	Check	Remedy	Notes	✓
	<ul style="list-style-type: none"> Check contacts and terminals. 	<ul style="list-style-type: none"> Clean contacts and terminals. 		
Battery charger	<ul style="list-style-type: none"> Check power cord for damage. 	<ul style="list-style-type: none"> Replace if necessary. 		
Remote / electronics module	<ul style="list-style-type: none"> Remote, status display blinking 	<ul style="list-style-type: none"> Evaluate error/blink code. 	See chapter 6.1.1	
	<ul style="list-style-type: none"> Fixings 	<ul style="list-style-type: none"> Tighten fixings, replace if necessary. 		
	<ul style="list-style-type: none"> Cables and connecting plugs 	<ul style="list-style-type: none"> Tighten cables and connecting plugs, replace if necessary. 		
	<ul style="list-style-type: none"> Joystick function 	<ul style="list-style-type: none"> Replace joystick if necessary. Replace remote if necessary. 		
	<ul style="list-style-type: none"> Power supply 	<ul style="list-style-type: none"> Tighten cables and connecting plugs, replace if necessary. 		
Drive program	<ul style="list-style-type: none"> Check drive electronics program version. 	<ul style="list-style-type: none"> Update software if newer version available. 	See chapter 8.3	
Labels	<ul style="list-style-type: none"> Check that present and legible. 	<ul style="list-style-type: none"> Replace if necessary. 		

6 Operational faults

Different power modules can be installed in the mobility device in connection with different remotes. The rectification of operational faults depends on the installed power module in each case.

If you have problems with the mobility device, please proceed as follows:

- First assess the possible cause of the problem using the following table.
- Check the remote status display. Evaluate the error code.
- Carry out the necessary checks and repairs as recommended in the following table.

6.1 Troubleshooting



Note

For additional troubleshooting information and explanations of error codes, refer to the individual remote manuals supplied with each wheelchair.

Chair veers left/right	Sluggish turn/performance	Casters flutter	Squeaks and rattles	Looseness in chair	Solutions
x	x	x	x	x	Check for loose stem nuts/bolts.
x		x			Check that both casters contact ground at the sametime.

The remote display and the service indicator give indications of the type of fault or error detected by the control module. When a fault is detected, the wheelchair may stop and not drive.

The LEDs on the display may flash in a particular pattern or the service indicator light will flash. The number or type of flashes indicates the nature of the error. If multiple errors are found, only the first error encountered by the control module will be displayed.

6.1.1 Service Indicator Diagnostics (Shark 2/MK5 SPJ+)

Number of Flashes	Diagnostics Code	Error Code Description	Sub Code	Details of Error Code	Possible Solution
1	E01	User Fault	00	Stall Timeout or user error.	Release joystick to neutral and try again.
2	E02	Battery Fault	00	Recharge batteries or replace.	Check the batteries and cable. Try charging the batteries. Batteries may require replacing.
3	E03	Left Motor Fault	00	Left Motor Short Circuit	Check the left motor, connections and motor cable.
			01	Left Motor Open Circuit	
			02	Left Motor Connection Fault B-	
			03	Motor Terminal Connected to B+	
			04	Left Motor Voltage Fault	
			05	Left Motor Bridge Fault	
			06	Too Many Hardware Current Limit Events	
			07	Current Offset Out of Range	
			08	Hardware Current Limit Fault	
4	E04	Right Motor Fault	00	Right Motor Short Circuit	Check the right motor, connections and motor cable.
			01	Right Motor Open Circuit	
			02	Right Motor Connection Fault B-	
			03	Motor Terminal Connected to B+	
			04	Right Motor Voltage Fault	
			05	Right Motor Bridge Fault	
			06	Too Many Hardware Current Limit Events	
			07	Current Offset Out of Range	
			08	Hardware Current Limit Fault	

Number of Flashes	Diagnostics Code	Error Code Description	Sub Code	Details of Error Code	Possible Solution
5	E05	Left Park Brake Fault	00	Left Park Brake Drive-Time Test Failed	Check the left park brake connections and cable.
			01	Left Park Brake Output Enabled When Wheelchair Idle	
			02	Left Park Brake Output Did not Enable When Entering Drive Mode	
			03	Left Park Brake fault during power-up testing	
			04	Left park brake feedback low during drive (park brake short)	
6	06	Right Park Brake Fault	00	Right Park Brake Drive-Time Test Failed	Check the right park brake connections and cable.
			01	Right Park Brake Output Enabled When Wheelchair Idle	
			02	Right Park Brake Output Did not Enable When Entering Drive Mode	
			03	Right Park Brake fault during power-up testing	
			04	Right park brake feedback low during drive (park brake short)	
7	E07	Remote Fault	00	Local SR Fault (CPU, EEPROM, etc.)	Check the communications bus, connections and wiring. Replace the remote.
			01	Joystick fault at the remote	
			02	Speed pot fault at the remote	
8	E08	Power module Fault	00	Power module fault	Check connections and wiring. Replace power module.
			01	RAM fault	
			02	ROM fault	
			03	CPU fault	
			04	EEPROM fault	

Number of Flashes	Diagnostics Code	Error Code Description	Sub Code	Details of Error Code	Possible Solution
			05	Watchdog fault	
			06	Stack fault	
			07	Software fault	
			08	Power-up testing fault	
			09	Relay fault or precharge fault	
			10	Bridge fault or disable all fault	
			11	Electronics fault: Thermistor	
			12	Calibration setting fault	
9	E09	Communications Fault	00	Remote connection lost	Check connections and wiring. Replace Bus cable.
			01	Low communication mode	
10		General Fault	00	General fault	Check all connections and wiring. Contact Invacare Technical Service.
11		Incompatible/incorrect Remote	00	Incompatible/incorrect Remote	Wrong type of remote connected. Ensure the branding of the joystick matches that of power module unit.

6.1.2 Service Indicator Diagnostics (ACS2)

BLINK CODE	POSSIBLE CAUSE	SOLUTION	DOCUMENTATION
1 x blink	Module defective	Replace defective module	See chapter 8.2
2 x blink	Accessory error (for example short circuit in the actuator)	Check accessory connections, check accessory	See chapter 7.6
	Lifter too high or too low (seat not at driving height)	If the lifter is raised, lower it slowly until the status display stops blinking. If the lifter is too low, raise it slowly until the status display stops blinking. Only drive when the seat is at driving height.	See operating manual
3 x blink	Error in motor M1 Connection loose/faulty or motor faulty	Check connection plug, check motor	See chapters 8.8.2 and 7.1
4 x blink	Error in motor M2 Connection loose/faulty or motor faulty	Check connection plug, check motor	See chapters 8.8.2 and 7.1
5 x blink	Fault/brake fault in motor M1. Connection loose or faulty or motor faulty	Check connection plug, check motor	See chapters 8.8.2 and 7.1
6 x blink	Fault/brake fault in motor M2. Connection loose or faulty or motor faulty	Check connection plug, check motor	See chapters 8.8.2 and 7.1
7 x blink	Completely discharge battery	Pre-charge battery	See operating manual
8 x blink	Battery voltage too high	Switch lighting to low battery voltage Check battery charger	See charging unit operating manual
9 or 10 x blink	Faulty data transmission between modules	Remove electronic modules except for the power module and the remote. Replace the modules one after another in order to ensure which was the one causing the fault.	See chapter 8.2
11 x blink	Drive motors overloaded / overheated	Switch remote on and off / wait if necessary	-
12 x blink	Compatibility problems between modules	Remove incorrect module	See chapter 8.2

6.1.3 Motor/Gearbox/Brake

Problem	Probable Cause	Solutions	Documentation
Motor makes a clicking noise.	Bad bearings.	If bearings are bad, replace motor.	See chapter 8.6.1.
	Raised commutator plate inside of motor.	Ohm out motor and replace motor if high reading is present. Normal reading is 0.5-5 Ohms.	See chapter 7.1 or chapter 8.6.1.
Grinding noise or motor is locking up.	Bad bearings. Bad gears.	Replace motor/gearbox.	See chapter 8.6.1
Motors stall and start up again.	Current rollback.	Stop driving and let electronics cool.	
Motor chatters or runs erratically, or only one motor turns.	Damaged connector or worn brushes. Bad motor or gear box.	Ohm out motors. Replace motor/gearbox if high reading is present. Normal reading is 0-5 Ohms.	See chapter 7.1, chapter 7.2 or chapter 8.6.1.
	Motor release lever is disengaged.	Engage motor release levers.	See chapter 8.4.1.
	Power module malfunction.	Check for error codes with programmer.	See electronics manual.
Wheelchair veers to the left or right when driving on level surface.	Uneven tire pressure. Motors out of balance.	Inflate tires. Replace tires if worn. Use programmer to balance motors.	
Gearbox is leaking fluid.	Bad seal around drive shaft.	If seal is bad, replace motor/gearbox.	See chapter 7.2 or chapter 8.6.1.
	Loose hardware.	If loose hardware is found retighten hardware.	
Excessive clicking coming from motor/gearbox.	Bad bearing in motor or gearbox.	Replace motor/gearbox:	See chapter 8.6.1.
	Loose wheel hardware.	Tighten hardware, (use removable Loctite™ on hardware).	Follow torque settings in this manual.
Rough driving.	Gearbox shaft movement or bent shaft.	Replace motor/gearbox.	See chapter 8.6.1.
Motor stutters.	Poor connection or worn brushes.	Check DCL connectors. Check motor and replace if necessary.	See chapter 8.6.1.
Motor fails to start after initial installation.	Battery voltage is too low.	Check batteries and recharge if necessary.	See chapter 8.7.
	Bad connection. Brake disengaged.	Check connector. Engage brake.	
Motor is running then fails to restart when stopped.	Heavy load on the motors forcing power module into the current rollback mode.	Leave power On and allow power module to count down, and recharge the batteries overnight with power On.	

Problem	Probable Cause	Solutions	Documentation
	Blown fuse in battery wiring harness.	Replace battery wiring harness.	See chapter 8.7.4.
	Damaged motor.	Replace motor/gearbox if internal damage is determined.	See chapter 7.2 or chapter 8.6.1.
		Ohm out motor to check for possible internal damage (worn out brushes may be possible).	See chapter 7.1 or chapter 7.2.
	Power module power stage board or relays may be damaged.	Replace power module or send to Invacare for repair.	See chapter 8.2.6.
Motor runs but loses power.	Power module senses heavy load and has entered the current rollback mode.	Stop driving and let electronics cool.	
	Batteries are going bad.	Replace batteries.	See chapter 8.7.3.
Actuator does not react	Actuator module defective. (ACS2 remotes only: Remote shows flashing "E" ¹ or flash code 2 ² . Status diode on actuator module does not go out even if the remote has been switched off or disconnected.)	Replace actuator module.	See chapter 8.2.5
	Cable disconnected or damaged.	Safeguard cable connection, replace cable if necessary.	See chapter 8.8.2
	Actuator defective.	Check actuator.	
	Remote defective.	Replace remote.	See chapter 8.2.1 or 8.2.3

¹ Only applies to remote SD24

² All ACS2 remotes except SD24

6.1.4 Battery

Problem	Probable Cause	Solutions	Documentation
Batteries won't charge.	Blown battery fuse or damaged cables.	Check cables for damage or replace battery wiring harness.	See chapter 8.7.4.
	Batteries sat discharged too long.	Replace batteries.	See chapter 8.7.3.
Short charge time	One or both batteries may be bad (if batteries charge up to soon).	Check each battery and replace if needed.	See chapter 8.7.3.
No power to wheelchair motors.	Bad connection or blown fuse. Check joystick connection.	Check all connections and housings for damage. If you have blown fuse a new battery wiring harness must be purchased.	See chapter 8.7.4.
	Batteries are dead.	Check battery voltage and replace if necessary.	See chapter 8.7.3.
	Loose battery connections.	Check battery cable connections, may have vibrated loose when driving on rough terrain.	
Corroded battery wiring connections.	Possible water, salt, or urine damage.	Replace battery wiring harness.	See chapter 8.7.4.

6.1.5 Battery Charger

PROBLEM	PROBABLE CAUSE	SOLUTIONS	Documentation
No LED's on charger.	Charger not plugged into outlet, or disconnected from wiring harness on wheelchair.	Make sure the charger is plugged into the outlet and check the wiring on the wheelchair.	
	No AC power at outlet.	Check for AC power with digital volt meter.	
	Damaged power cord.	Check for damage on the power cord, replace if damaged or send to Invacare for repair.	
	Charger LED's burnt out.	Replace charger.	
	Charger may have internal fuse that is blown.	Remove charger cover and check for fuses. If fuses are present, ohm out fuses and replace if necessary.	
Batteries have short driving range during a single charge. Battery gauge falls off faster than normal.	Consumer not charging batteries long enough.	Instruct consumer to charge for 8-10 hours minimum.	
	Batteries may be weak.	Perform load test or check "Battery Quality Menu" with the programmer.	See electronics manual. See chapter 7.4.
	Check programming settings.	Torque setting and power level setting may be too high.	See electronics manual.
	Heavy load on motors.	Chairs weight distribution may be offset (wheelchair may be front loaded).	
Batteries won't charge.	Blown battery fuse in wiring harness, or charger.	Check battery wiring harness fuse on the wheelchair. Replace battery wiring harness if fuse is blown. Check fuse in the charger.	See chapter 8.7.4.
	Charger not plugged into outlet.	Make sure charger is plugged into the outlet.	
	No AC power at the outlet.	Check for AC power with a digital volt meter.	
	Charger power cord may be damaged, or the connector may be damaged.	Check for damage and replace if necessary.	
	Charger may have internal damage.	Charge batteries with known good charger.	
	Battery voltage too low for charger to start charging cycle.	Replace batteries.	See chapter 8.7.3.

7 Initial test procedures

7.1 Testing the motor

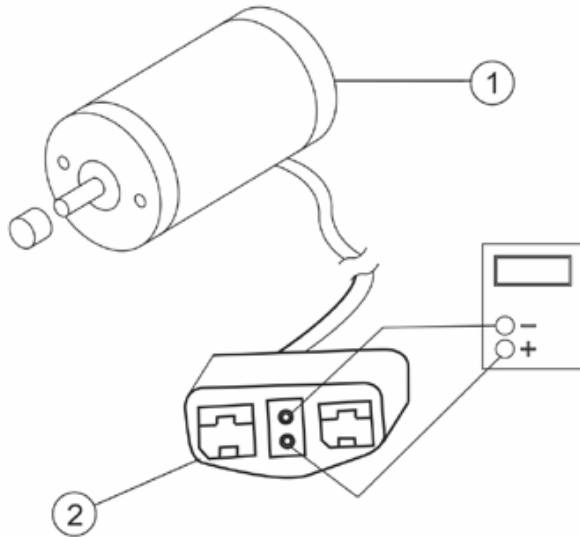

- On the 4-pin motor connector (2), locate the two contacts in the RED and BLACK housings.
- Set the digital multimeter to measure resistance (ohms).
- Measure the resistance between the two motor contacts.

**Note**

A normal reading is between 0.5 and 5 ohms. A reading of 0 ohms or in excess of 15 ohms indicates a problem. High readings are generally caused by bad connections and/or damaged brushes. Contact Invacare.

7.2 Testing the electro-mechanical parking brake



Note

This procedure should only be performed on wheelchairs with conventional motor/gearbox assembly.

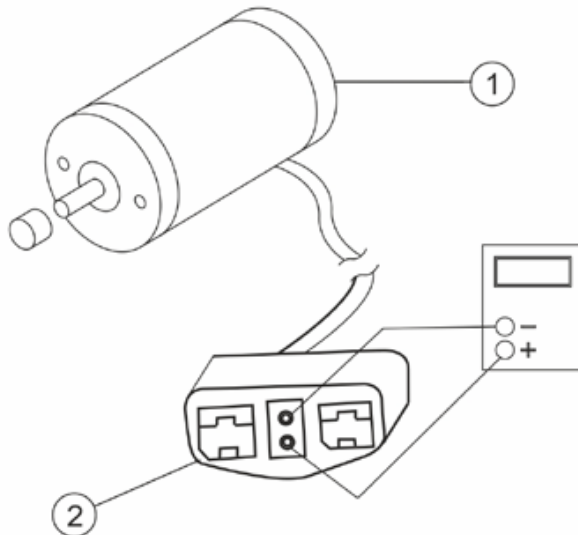

- Engage the motor release lever, as described in chapter 8.4.1
- On the four-pin motor connector (2), locate the side by side connectors in the black housings.
- Set the digital multimeter to read ohms.
- Measure the resistance between the two brake contacts.
- A normal reading is between 45-100 ohms depending on the motor (1).
- A reading of 0 ohms or a very high reading (Megohms or O.L. (out of limit)) indicates a shorted brake or an open connection respectively. If either condition exists, send the motor to Invacare Technical Service for inspection/repair.



WARNING!

A shorted electro-mechanical brake will damage the brake output section in the power module.

Do not connect a shorted electro-mechanical brake to a good power module. A shorted brake must be replaced.



Note

A bad motor can damage the power module but a bad power module will not damage a motor.

7.3 Rain test

- Check to ensure that the **RED** and **GREY** battery terminal caps are secured in place, joystick boot is not torn or cracked where water can enter and that all electrical connections are secure at all times.
- Do not use the wheelchair if the joystick boot is torn or cracked. If the joystick boot becomes torn or cracked, replace IMMEDIATELY.

7.4 Field load test

Old batteries lose their ability to store and release power due to increased internal resistance. In this procedure, batteries are tested under load using a digital voltmeter to check battery charge level at the charger connector. The charger connector is located on the joystick. When voltage at the output drops 1.0 volts under load (2.0 for a pair), replace the batteries.



Note

Read these instructions carefully and the manufacturer's instructions on the digital voltmeter before proceeding.

- Switch the electronics OFF on the remote.
- Make sure battery is fully charged. An extremely discharged battery will exhibit the same symptoms as a bad battery.
- Remove the footboard from the wheelchair. Refer to chapter 8.13.

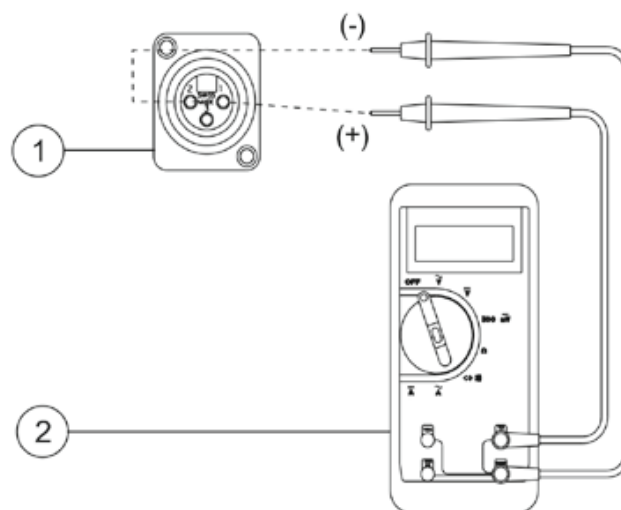

- Connect the voltmeter leads to the charger connector (1) on the wheelchair. Most digital voltmeters (2) are not affected by polarity; however, analog meters (meters with swinging needles) can be and should be used carefully. A good meter reading should be 25.0 to 25.8 VDC with the chair in neutral.



WARNING!

When performing the remaining steps, ensure your feet are clear from casters and wall, otherwise injury may result.

- Run the wheelchair in neutral for at least 2 minutes.
- Sit in wheelchair and place your feet against a door jam, workbench, or other stationary object.
- Carefully push the joystick forward, trying to drive the wheelchair through the stationary object. The load should draw between 30 to 40 amps from the batteries for 0.3 seconds.



Note

Performing the last step puts a heavy load on the batteries as they try to push through the stationary object. If the wheels spin, have two individuals (one on each arm) apply as much downward pressure as possible on the arms of the wheelchair.

- Read the meter while the motors are straining to determine the voltage under load.



Note

If the voltage drops more than 2.5 volts from a pair of fully charged batteries during the 0.3 seconds, they should be replaced regardless of the unloaded voltages.

7.5 Checking battery charge level

The following “Do” and “Do not” are provided for your convenience and safety.

Do	Do not
Read and understand this manual and any service information that accompanies a battery and charger before operating the wheelchair.	Do not perform any installation or maintenance without first reading this manual.
Move the wheelchair to a work area before opening battery box or installing service batteries	Do not perform installation or maintenance of batteries in an area that could be damaged by battery spills.
Recharge as frequently as possible to maintain a high charge level and extend battery life.	Do not make it a habit to discharge batteries to the lowest level.
Follow recommendations in this manual when selecting a battery or charger.	Do not use randomly chosen batteries or chargers.
Fully charge new batteries before using.	Do not put new batteries into service before charging.
Use a carrying strap to remove, move or install a battery.	Do not tip or tilt batteries.
Push battery clamps on the terminals. Spread clamps wider if necessary.	Do not tap on clamps and terminals with tools.
Use ONLY a GEL charger for a GEL battery or “Sealed” battery.	Do not mismatch your battery and chargers.

7.6 Checking an actuator

- Switch the electronics OFF on the remote.
- Remove the rear cover, as described in chapter 8.1.3.
- Move the seat into the service position (Modulite seat), as described in chapter 8.9.2.1.
- Take exact note of the positions of all cables and the sockets that they are connected to. Mark the connectors and sockets or take a photograph with a digital camera.

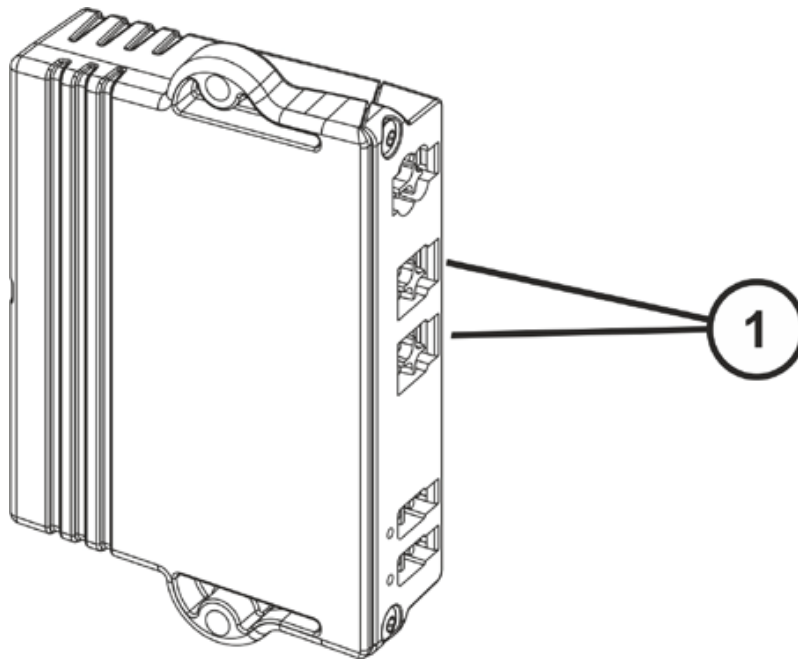

Disconnect the motor plug (1) of the motor to be tested from the actuator module.

- Check the electrical resistance at the plug (1) of the actuator. The plug can have a different shape than show in the illustration.
- If the resistance is close to infinity, the motor is probably burnt out.
- If the resistance is below 1Ω , the motor has a short-circuit.
- The motor must be replaced in both cases.

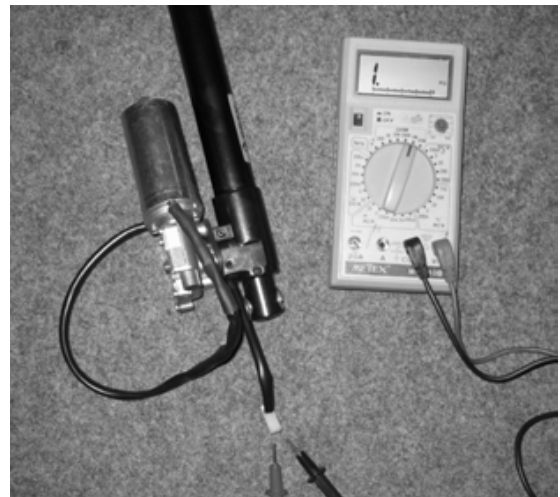

8 Repair work

8.1 Covers and frame



IMPORTANT!

After any adjustments, repair or service and before use, make sure that all attaching hardware is tightened securely - otherwise injury or damage may result.

- Before performing any maintenance, adjustment or service verify that ON/OFF switch on the joystick is in the OFF position.
 - To prevent cracking the plastic cover material, do not overtighten the mounting screws.
-

8.1.1 Removing/Installing the top cover



Requirements:

- Slotted screwdriver
 - Phillips screwdriver
-

Removing the front cover:

- Disconnect the joystick, as described in chapter 8.2.3.
- Remove the seat assembly, as described in chapter 8.9.1.1.
- Remove the two screws (2) that secure the top cover (5) to the frame.
- Remove the two screws (2) that secure both the top cover (5) and front cover (1) to the frame (3).
- Remove the top cover (5) by pulling the top cover forward then up in order to clear the motor release levers and seat post.

Installing the front cover:

- Pull joystick cable through the center hole in the top cover (5).
- Place the top cover (5) on the base frame.

**Note**

Pull the cover forward to clear the motor release levers.

- Install the two screws (2) that secure the top cover (5) to the frame (3). Do not overtighten.
- Attach the front cover (1) to the top cover (5).
- Install the two screws (2) that secure both the top cover (5) and front cover (1) to the frame (3). Do not overtighten.
- Install the seat assembly, as described in chapter 8.9.1.1.
- Connect the joystick, as described in chapter 8.2.3

8.1.2 Removing/Installing the front cover

**Requirements:**

- Slotted screwdriver
- Phillips screwdriver

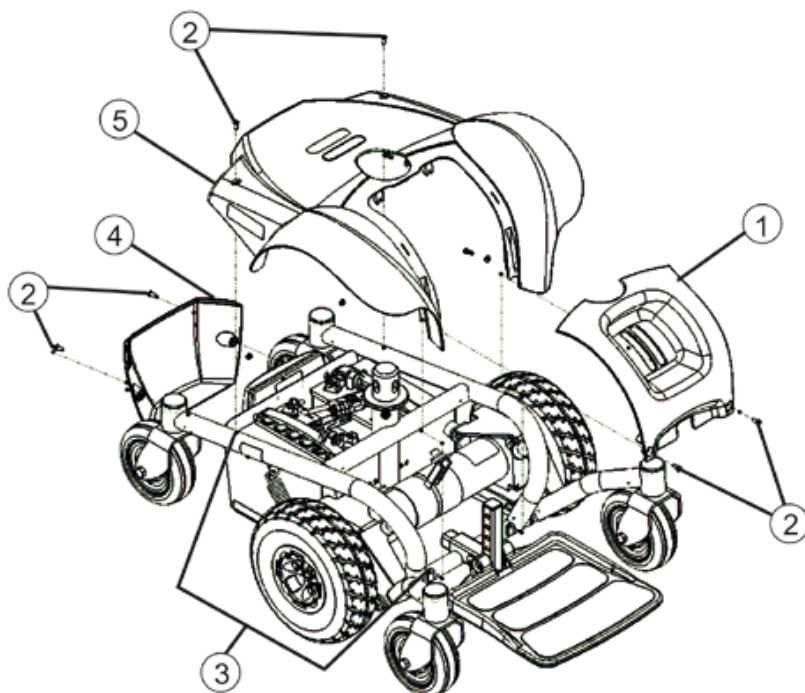
**Removing the front cover:**

- Remove the two screws (2) that secure both the top cover (5) and front cover (1) to the frame (3).
- Remove the front cover (1) from the frame (3).

Installing the front cover:

- Insert the tabs at the bottom of the front cover (1) into the slots in the bottom of the frame (3).
- Secure the bottom of the front cover (1) to the frame using the two screws (2). Do not overtighten.

8.1.3 Removing/Installing the rear cover

**Requirements:**

- Slotted screwdriver
- Phillips screwdriver

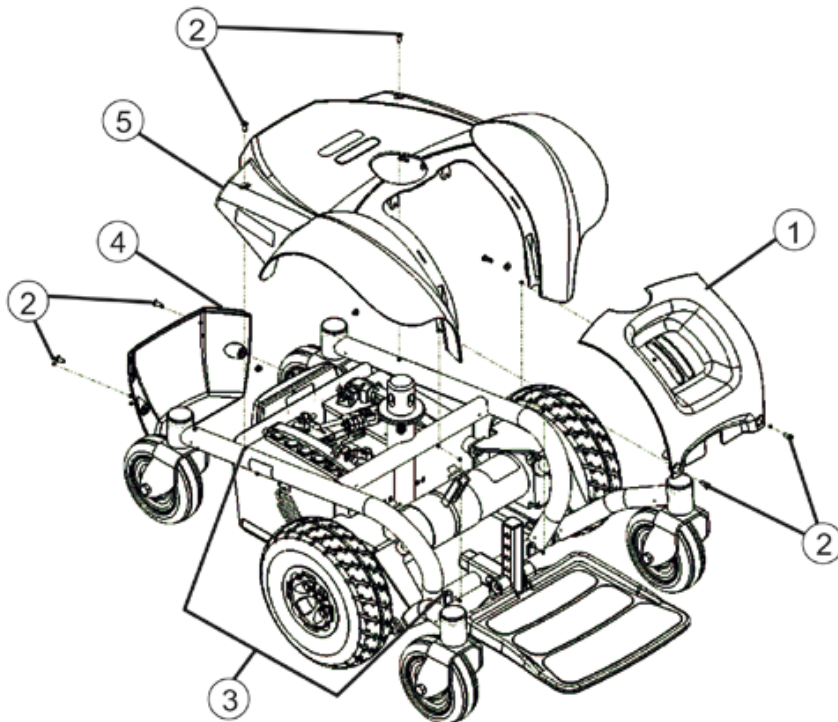
**Removing the rear cover:**

- Remove the two screws (2) that secure the rear cover (4) to the frame (3).
- Remove the rear cover (4).

Installing the rear cover:

- Insert the tabs at the bottom of the rear cover (4) into the slots in the bottom of the frame (3).
- Secure the rear cover (2) to the frame (3) using the two screws (2). Do not overtighten.

8.1.4 Removing/Installing the swingarm assembly

Requirements:

- 24 mm open-ended wrench
- 19 mm socket wrench
- 13 mm socket wrench
- 11 mm socket wrench

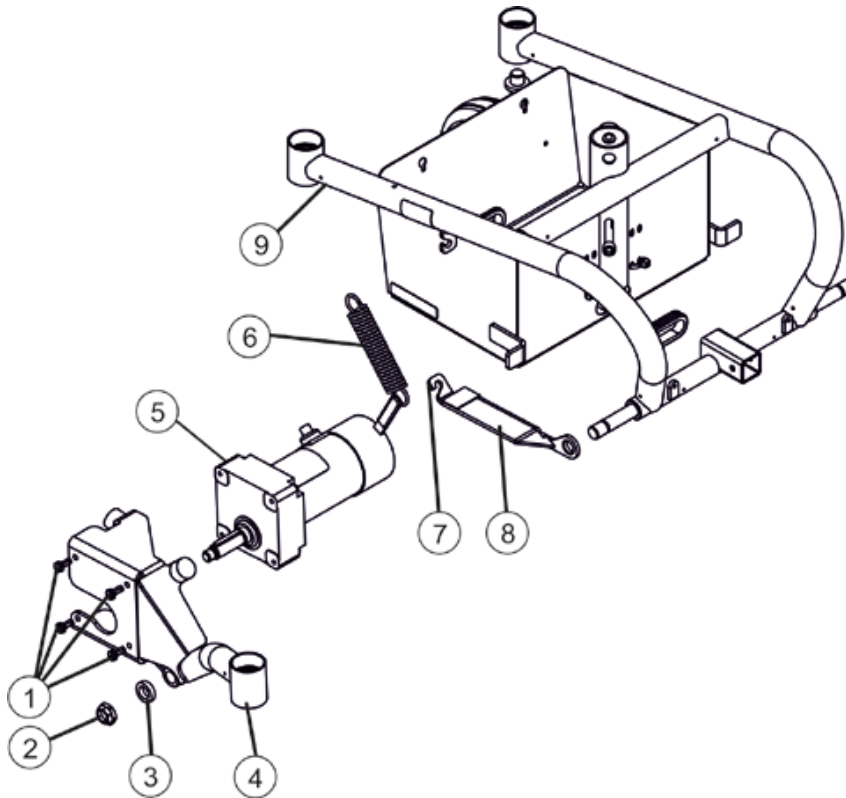

Removing the swingarm assembly:

- Remove the front caster assembly, as described in chapter 8.4.4
- Remove the drive wheel, as described in chapter 8.5.
- Ensure the front and top covers are removed. Refer to chapter 8.1.1 and chapter 8.1.2.
- Remove the four screws (1) that secure the swingarm (4) assembly to the motor.
- Remove the locknut (2) and spacer (3) that secure the swingarm (4) assembly and bracket (8) to the frame (9).

Installing the swingarm assembly:

- Install the locknut (2) and spacer (3) that secure the swingarm (4) assembly and bracket (8) to the frame.
- Install the four screws (1) that secure the swingarm (4) assembly to the motor (5).
- Install the drive wheel, as described in chapter 8.5.
- Ensure the front and top covers are installed. Refer to chapter 8.1.1 and chapter 8.1.2.
- Install the front caster assembly, as described in chapter 8.4.4.

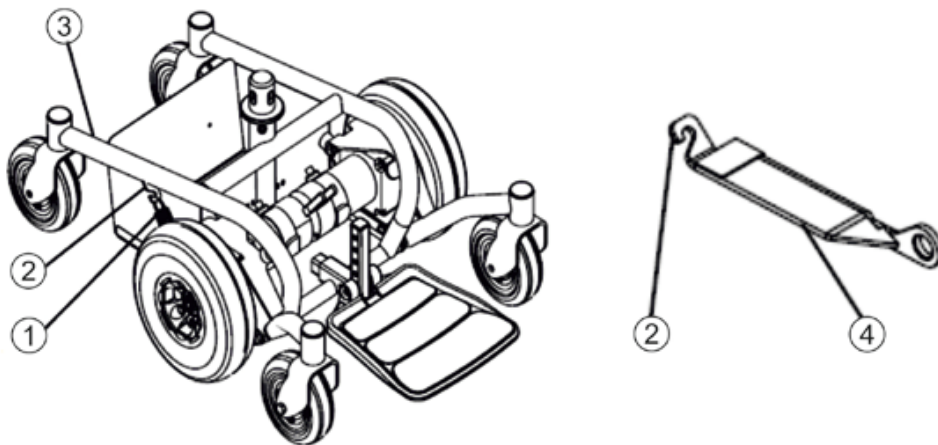
8.1.5 Removing/Installing the spring

**Removing the spring:**

- Unhook the spring (1) from the hooks (2) on the frame (3) and the bracket (4).

Installing the spring:

- Install the spring (1) to the hooks (2) on the frame (3) and the bracket (4).

8.2 Electronics



WARNING!

After any adjustments, repair or service and before use, make sure that all attaching hardware is tightened securely - otherwise injury or damage may result.

- Before performing any maintenance, adjustment or service verify that On/Off switch on the joystick is in the off position.

8.2.1 Removing/Installing the joystick (office style seat)

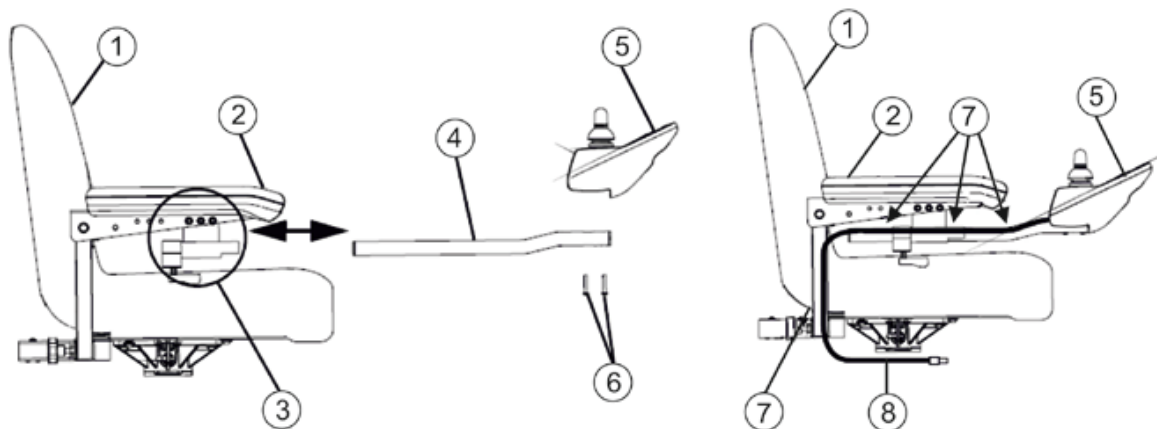

1	Seat	4	Joystick mounting tube	7	Tie-wrap here
2	Standard arm	5	Joystick	8	Joystick cable
3	Mounting bracket and adjustment lock lever	6	Mounting screws		

Removing the joystick:

- Disconnect the joystick, as described in chapter 8.2.3.
- Cut the tie-wraps (7) that secure the joystick cable (8) to the arm (2).
- Loosen the adjustment lock lever (3) to release the joystick mounting tube (4) from the mounting bracket (3).
- Remove the joystick (5) and joystick mounting tube (4) from the mounting bracket (3).

Installing the joystick:

- Slide joystick mounting tube (4) through the mounting bracket (3) to the desired position.
- Tighten the adjustment lock lever (3) to secure the joystick mounting tube (4) to the mounting bracket (3) on the other arm (2).
- Tie-wrap (7) the joystick cable (8) to the arm (2).
- Connect the joystick, as described in chapter 8.2.3.
- Ensure the arm (2) can swing fully up without pulling on the joystick cable (8).

8.2.2 Repositioning the joystick mounting bracket (office style seat)



Note

Take note of position and orientation of mounting hardware for reinstalling the joystick assembly.



Requirements:

- 2 x 1/4" open-ended wrenches

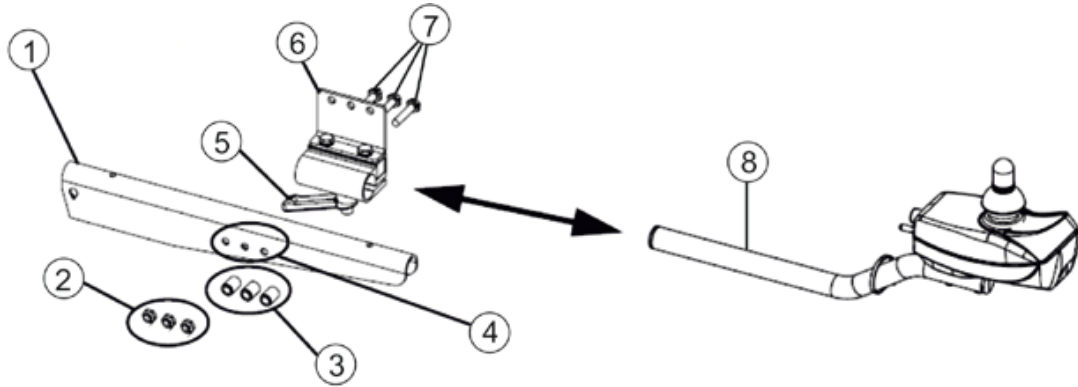

1	Armrest plate	4	Mounting holes on arm frame	7	Hex mounting screws
2	Locknuts	5	Adjustment lock lever	8	Joystick mounting tube
3	Spacers	6	Mounting bracket		

- Turn the adjustment lock lever (5) to release the joystick mounting tube (8) from the mounting bracket (6).
- Remove the joystick from the wheelchair.
- Remove the three hex mounting screws (7), spacers (3) and locknuts (2) that secure the mounting bracket (6) to the three mounting holes on the arm frame (4).



Note

The mounting bracket is mounted to the inside of the arm frame.

- Reposition the mounting bracket (6) on the opposite arm frame.
- Using the three hex mounting screws (7), spacers (3) and locknuts (2) secure the mounting bracket (6) to the three mounting holes of the arm frame (4).
- If necessary, perform the following to reposition the adjustment lock:
 - Slide the adjustment lock from the mounting bracket.
 - Rotate adjustment lock 180° and slide adjustment lock over the opposite end of the mounting bracket.
- Slide joystick mounting tube (8) through the mounting bracket (6) to the desired position and secure adjustment lock to tube by turning lever on adjustment lock (5).

8.2.3 Disconnecting/Connecting the joystick

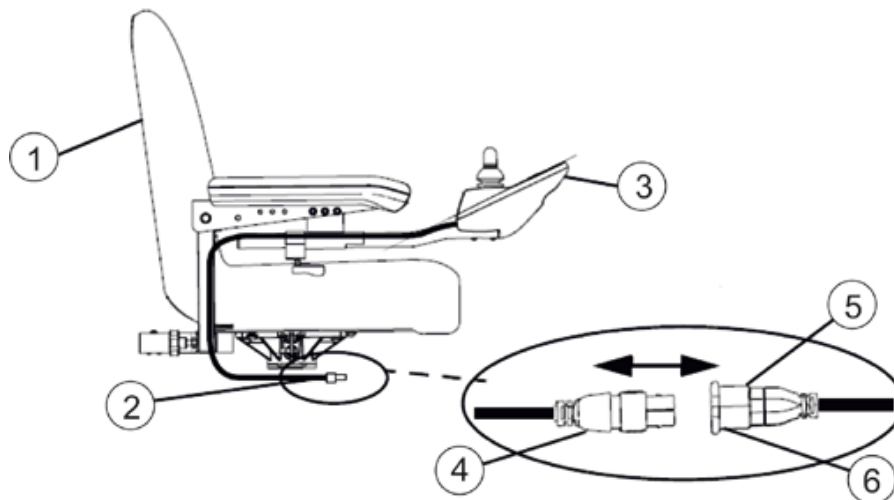

1	Seat	4	Light grey collar
2	Joystick cable	5	Power module connector
3	Joystick	6	Joystick connector

Disconnecting the joystick:

- Hold the light Grey collar (4) portion of the joystick connector (6) with one hand and the power module connector (5) on the wheelchair in the other and disconnect them by pulling them apart.

Connecting the joystick:



IMPORTANT!

- *The joystick connector and power module connector fit together in one way only. Do not force them together.*
- Hold the light grey collar portion (4) of the joystick connector (6) with one hand and the power module connector (5) on the wheelchair in the other and align them.
- Lightly push to engage the joystick connector (6) and the power module connector (5).

8.2.4 Replacing the ACS2 power module



Note

When replacing the power module in connection with a remote, please take the final selection of the drive program into account as described in chapter 8.3.

Different power modules in connection with different remotes can be fitted to the mobility aid. The possible power modules are described in chapter 4.2.



IMPORTANT!

Any changes to the drive program can affect the driving characteristics and the tipping stability of the mobility aid!

- *Changes to the drive program may only be carried out by trained Invacare® specialist dealers!*
- *Invacare® can only give a warranty for safe mobility aid driving behaviour - especially tipping stability - for unaltered standard drive programs!*



Note

All power modules are delivered with a standard drive program. If you have made any customer-specific modifications to the drive program, these must be adapted after the installation of the new power module.



Requirements:

- 8 mm socket wrench
- To adapt the drive program:
programming software or hand programming device and system installation manual, available from Invacare®.

Removing the power module:

- Switch the electronics OFF on the remote.
- Remove the seat, as described in chapter 8.9.1.1.
- Move the seat into the service position (Modulite seat), as described in chapter 8.9.2.1.
- Remove the rear cover and top cover, as described in chapters 8.1.1 and 8.1.3.
- Take exact note of the positions of all cables and the sockets that they are connected to. Mark the connectors and sockets or take a photograph with a digital camera.

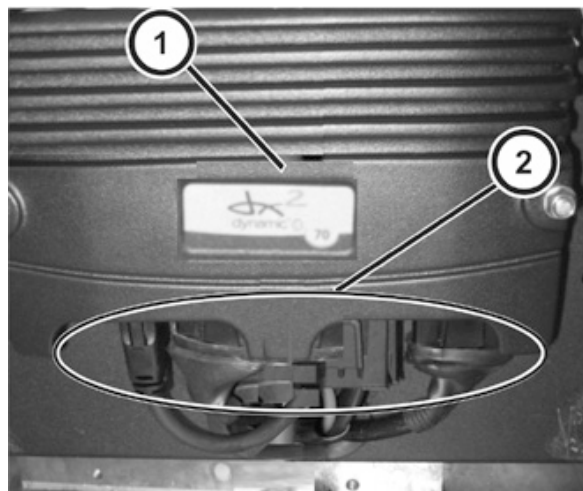

- Disconnect the plugs (2) from the power module (1).

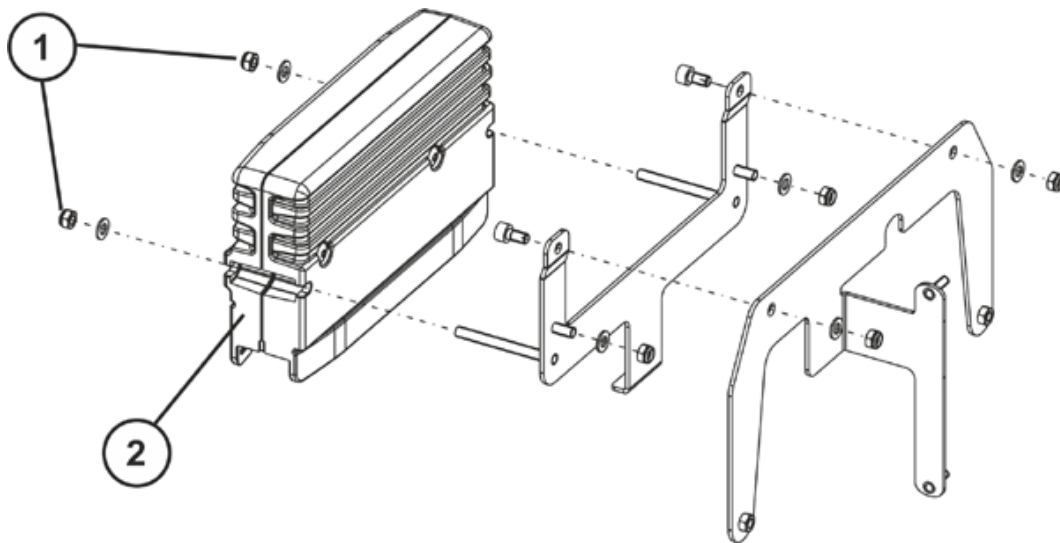

- Use the 8 mm socket wrench to loosen self-locking nuts (2) and remove the nuts including the washers.
- Pull the power module towards the rear and off of the guides.
- Replace the power module.

Installing the power module:

- Assemble the parts in reverse order.
- Reconnect all cable connectors to their former positions.
- Plug all free slots with a suitable rubber stopper, see chapter 4.2.1.
- Select and update the driving program if a new software version is available, as described in chapter 8.3.
- Modify the driving program using the programming software as needed.
- The last step is to test all functions of the vehicle.

8.2.5 Replacing the actuator module



Requirements:

- 4 mm Allen key
- 8 mm socket wrench
- 7 mm socket wrench (actuator module)

Removing the actuator module:

- Switch the electronics OFF on the remote.
- Move the seat into the service position (Modulite seat), as described in chapter 8.9.2.1.
- Remove the rear cover and top cover, as described in chapters 8.1.1 and 8.1.3.

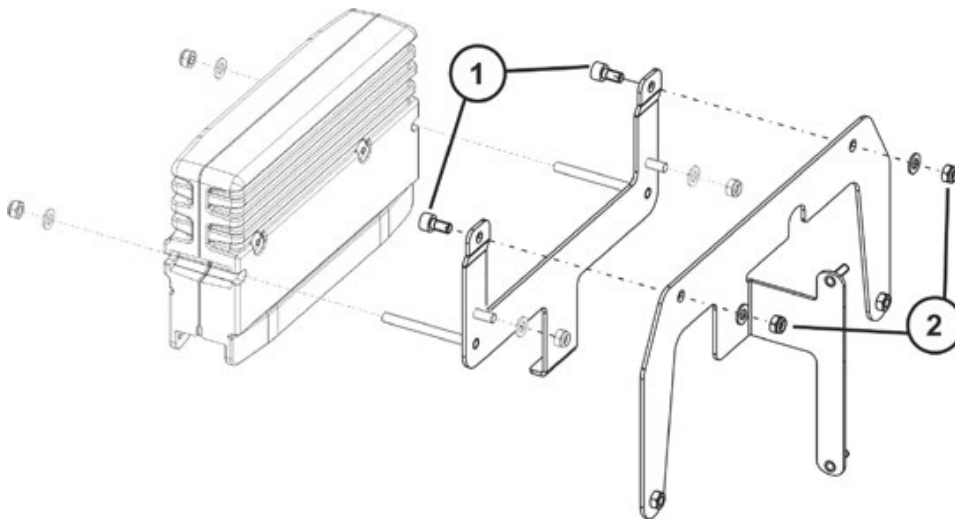

- Loosen and remove the self-locking nuts (2) and the Allen screws (1) including the washer with a 4 mm Allen key and an 8 mm socket wrench.

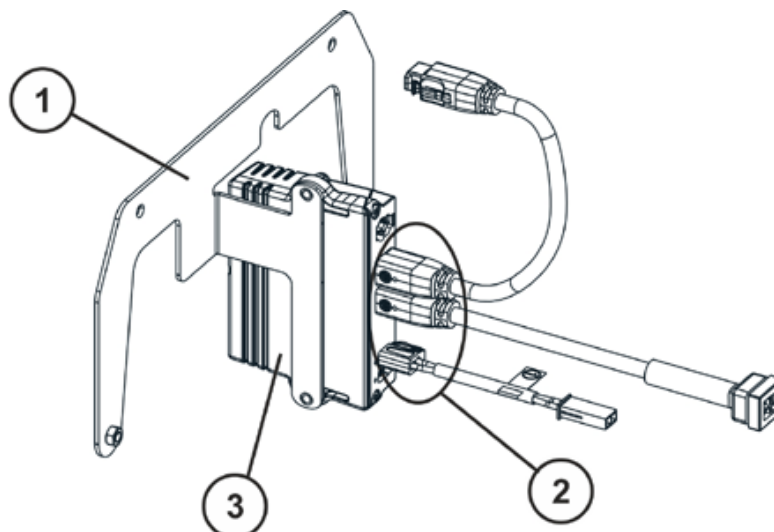

- Pull the actuator holder (1) carefully upwards out of the chassis.
- Take exact note of the positions of all cables and the sockets that they are connected to. Mark the connectors and sockets or take a photograph with a digital camera.
- Disconnect the plugs (2) from the actuator module (3).

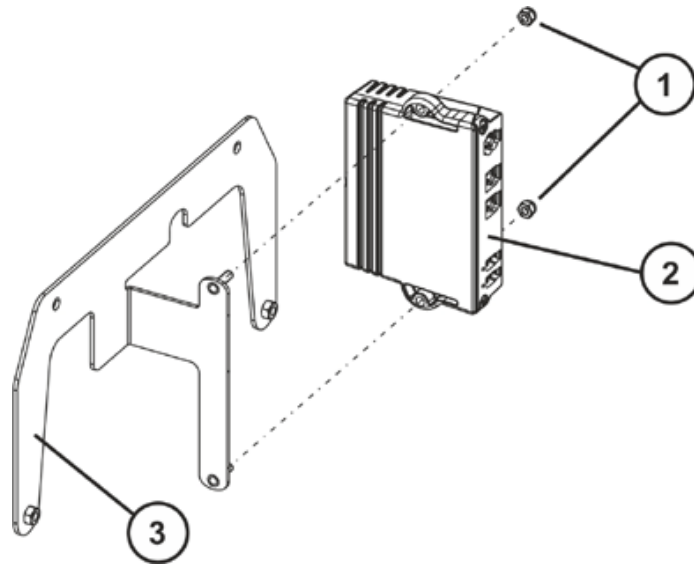

- Loosen and remove the self-locking nuts (1) with a 7 mm socket wrench.
- Pull the actuator module (2) from the holding (3).
- Replace the actuator module.

Installing the actuator module:

- Assemble the parts in reverse order.
- Reconnect all cable connectors to their former positions.
- Plug all free slots with a suitable rubber stopper, see chapter 4.2.2.
- The last step is to test all functions of the vehicle.

8.2.6 Replacing the Shark power module



WARNING!

Do not attempt to perform this procedure with any power supplied to the wheelchair. The joystick and batteries (6) must be disconnected prior to beginning to remove the power module. Otherwise, equipment damage and/or personnel injury may occur.



Note

There are four cables connected to the power module. These cables must be disconnected before the power module can be removed.

Take note of position and orientation of the power module, cables, connectors and mounting hardware for reinstallation of power module.



Requirements:

- Phillips screwdriver
- 8 mm open-ended wrench

- Remove the seat, as described in chapter 8.9.1.1.
- Remove the top cover (chapter 8.1.1) and front cover (chapter 8.1.2).
- Remove the rear cover, as described in chapter 8.1.3.
- Remove the batteries from the wheelchair, as described in chapter 8.7.3.

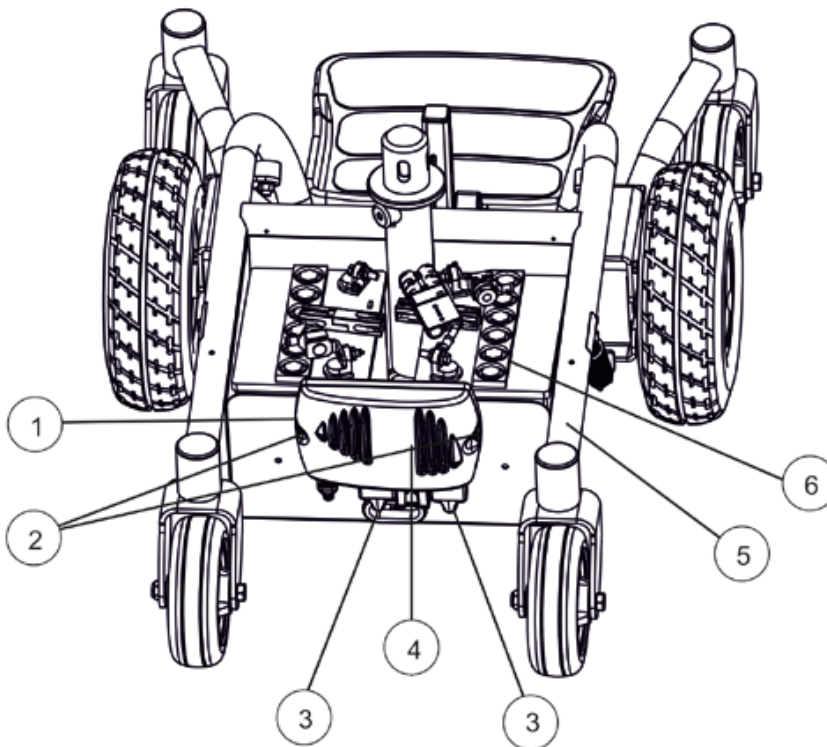

- Disconnect the right and left motor leads (3) from the power module (1).
- Disconnect the battery connector (4) from the power module (1).
- Disconnect the joystick cable from the power module.
- Remove the two mounting screws (2) and locknuts that secure the power module (1) to the frame (5).

- Remove the power module from the frame.
- Reverse the steps to install the new power module.

**Note**

Route the joystick cable (not shown) through the hole in the top cover (not shown) when installing the new power module.

Route the joystick cable, two battery cables, and the motor cable beneath the tabs.

8.3 Updating the driving program

The driving programs for power wheelchairs are continually updated and improved by Invacare®. For this reason, you should check whether the version number is still up to date each time a wheelchair comes in for repairs, and also during regular inspections.

If a newer version is available, the driving program must be updated. The procedure for updating the driving program is described in the user manual of the Wizard software.

**Note**

The electronic system is supplied with a standard drive program. If the driving program has been customised, you have to perform this customisation again, after installing the new driving program. This also applies to the customer-specific options of the seat setting for ACS2 remotes, which are activated ex works.

**WARNING!**

Every alteration to the drive program can influence vehicle handling and the tipping stability of the wheelchair!

- *Alterations to the drive program must only be carried out by trained Invacare®-dealers!*
- *Invacare® can only assume a warranty for the safe vehicle handling of the wheelchair – in particular tipping stability - for unaltered standard drive programs!*

**Pre-requisites:**

- Dynamic® Wizard software
- User manual for the Wizard software
- For further information on other requirements - such as the minimum system configuration of the PC to be used for programming, necessary programming cables - see the user manual of the Wizard software. You find the latest version of the user manual in the download area on <http://www.dynamiccontrols.com/>.

**Note**

When an electrical adjustment option is retrofitted, such as electrical legrests, then this option needs to be activated in the driving program as well if you have an ACS2 remote. For more information, refer to the user manual of the Wizard software and the installation instructions for the electronic modules

8.4 Wheels



WARNING!

After ANY adjustments, repair or service and before use, make sure all attaching hardware is tightened securely - otherwise injury or damage may result.

- Before performing any maintenance, adjustment or service verify that ON/OFF switch on the joystick is in the OFF position.

8.4.1 Engaging/Disengaging motor release lever



Note

Engaging/Disengaging motor release lever is described in the user manual.

8.4.2 Removing/Installing the front/rear casters



Note

Front and rear casters are replaced in the same manner.

When replacing the front/rear casters, it is necessary to brace the caster to prevent spinning.



Requirements:

- 2 x 16 mm open-ended or box spanners

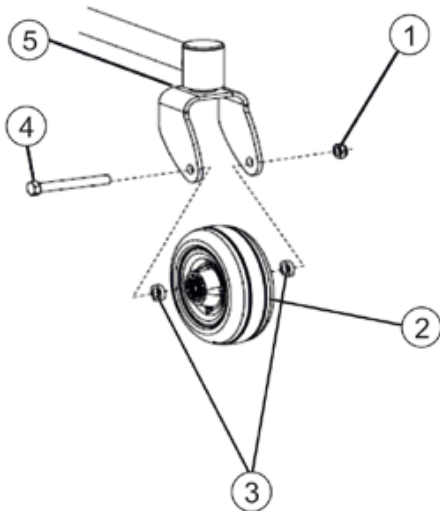

Removing the front/rear casters:

- Remove the mounting screw (4), two spacers (3), and locknut (1) that secure the caster (2) to the fork (5).
- Remove the caster (2).

Installing the front/rear casters:

- Secure new/existing caster (2) to fork (5) with mounting screw (4), two spacers (3), and locknut (1).
- Torque locknut (1) to 10 ft-lbs (14 Nm) (120 in-lbs (13,56 Nm)).
- Loosen the locknut (1) 1/8 of a turn.
- Move the caster (2) side to side.

**Note**

If the caster moves side to side, tighten the locknut slightly. Repeat the last step until there is no side to side movement of the caster.

8.4.3 Adjusting forks

**Requirements:**

- Ratchet with 15/16" socket

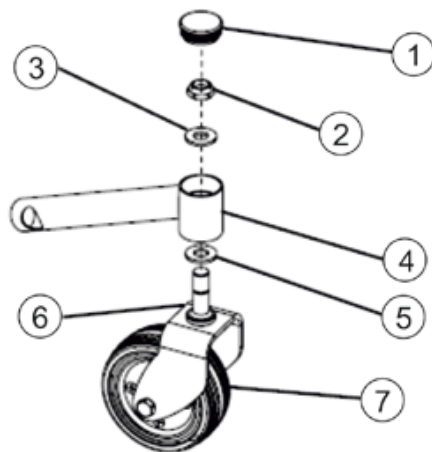

- Remove headtube cap (1).
- To properly tighten caster (7) assembly and guard against flutter, perform the following check:

**Note**

Two people are recommended to perform the steps a ... d - one person to tip the wheelchair back and one person to inspect/adjust the caster assembly.

- Tip back the wheelchair.
 - Pivot both caster (7) assemblies to top of their arc simultaneously.
 - Let casters drop to bottom of arc (casters should swing once to oneside, then IMMEDIATELY rest in a straight downward position).
 - Adjust locknut (2) according to freedom of caster (7) swing.
- Test wheelchair for maneuverability.
 - Readjust locknut (2) if necessary, and repeat steps a. ... d. until correct. Test wheelchair for maneuverability.
 - Replace the headtube cap (1).

8.4.4 Removing/Installing forks and/or caster assemblies

Note

Front and rear forks are replaced in the same manner.

Requirements:

- Ratchet with 15/16" socket

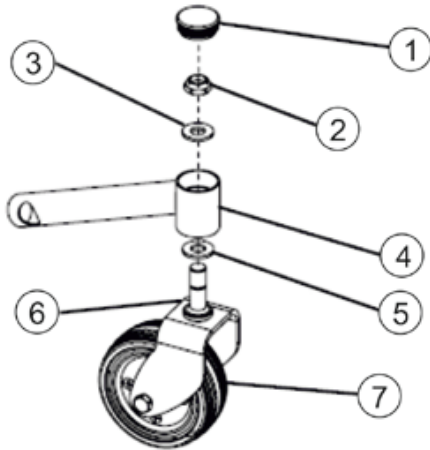
Removing forks and/or caster assemblies:

- Remove the caster (7) from the fork if necessary. Refer to chapter 8.4.2.
- Remove the head tube cap (1).
- Remove locknut (2), washer (3), and spacer (5) securing the fork (6) to the headtube (4).

Installing forks and/or caster assemblies:

- Insert the spacer (5) and the threaded post of the fork (6) into the headtube (4).

Note

Check the bearing assemblies. Replace if necessary.

- Slide the fork (6) completely into the headtube (4).
- Secure the fork (6) to the headtube (4) with the locknut (2) and washer (3). Securely tighten.

WARNING!

Improper positioning of the washer will prohibit the free movement of the forks which may result in injury to the occupant.

- Install the caster (7) onto the fork if removed, as described in chapter 8.4.2.
- Replace the headtube cap (1).

8.5 Drive wheels

8.5.1 Removing/Installing the drive wheel



Requirements:

- 19 mm socket spanner

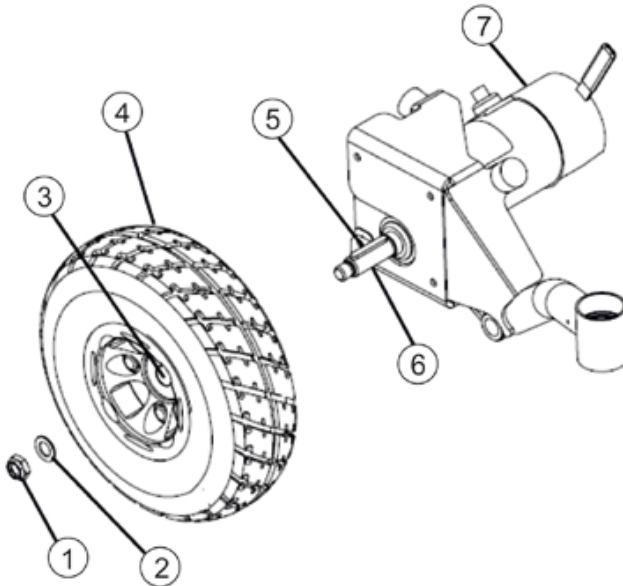

Removing the drive wheel:

- Remove locknut (1) and washer (2).
- Remove the wheel (4) from the drive shaft (6). If necessary, use a wheel puller to remove the wheel (4) from the drive shaft (6).

Installing the drive wheel:



Note

Ensure keystone (5) is in the cutout (3) on the drive shaft (6). The keystone (5) must line up with the wheel hub cutout.



IMPORTANT!

Do not apply more than a one-inch (25,4 mm) (in length) thin film of anti-seize compound to the drive shaft. Applying more than one-inch (25,4 mm) (in length) can cause the anti-seize compound to leak resulting in damage to flooring (carpet, tile, etc.).

- Apply an anti-seize compound to drive shaft (6) and keystone (5).
- Align the keystone (5) in the drive shaft (6) with the cutout (3) in the wheel hub and position the wheel (4) on to the drive shaft (6).



WARNING!

Failure to properly install the washer and locknut can result in wheel separation and potential user injury or property damage.

- *The locknut can only be re-used one to two times then replace.*

- Secure the wheel (4) to the drive shaft (6) with the washer (2) and locknut (1).

8.6 Drive unit



WARNING!

Personal injury or damage may occur in case of repairing or servicing the wheelchair.

- After ANY adjustments, repair or service and before use, make sure that all attaching hardware is tightened securely.
 - ALWAYS turn the wheelchair power off before repairing or servicing the wheelchair.
-

8.6.1 Removing/Installing the motor



Note

Reverse this procedure to install the motor.



Requirements:

- 24 mm open-ended wrench
 - 19 mm socket wrench
 - 13 mm socket wrench
 - 11 mm socket wrench
-

- Remove the seat, as described in chapter 8.9.1.1.
- Remove the front cover, as described in chapter 8.1.2.
- Remove the batteries, as described in chapter 8.7.3.
- Place two 5-inch (12 cm) blocks under battery frame to lift frame off the ground for ease in performing this procedure. Use proper lifting techniques.
- Remove the drive wheel, as described in chapter 8.5.
- Cut all tie-wraps securing the motor lead to the frame (not shown).
- Remove the rear cover, as described in chapter 8.1.3.
- Disconnect the motor lead connectors from the power module.
- Unhook the spring from the frame and bracket, as described in chapter 8.1.5.

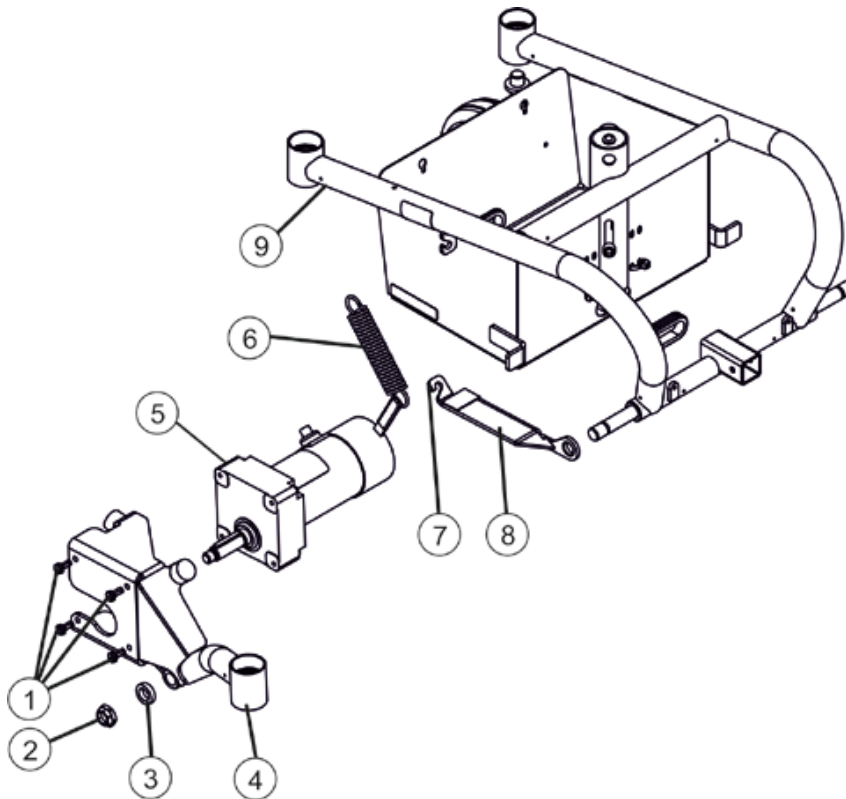

- Remove the locknut (2) and spacer (3) that secure the swingarm (4) assembly to the frame (9).
- Remove the swingarm (4) and motor (5).
- Remove the four screws (1) that secure the swingarm (4) assembly to the motor (5).
- Separate the motor from the swingarm.
- Position the new motor against the swingarm assembly.
- Install the four screws (4) that secure the motor to the swingarm assembly.
- Install the locknut (2) and spacer (3) that secure the swingarm assembly to the frame.
- If necessary, repeat the steps for the motor on the other side.
- Reverse the first nine steps to reassemble the base.

8.7 Batteries

8.7.1 Warnings for handling and replacing batteries



WARNING!

After any adjustments, repair or service and before use, make sure that all attaching hardware is tightened securely - otherwise injury or damage may result.

- Make sure power to the wheelchair is off before performing this section.
 - The use of rubber gloves is recommended when working with batteries.
 - Invacare strongly recommends that battery installation and battery replacement ALWAYS be done by a qualified technician.
 - Batteries are very heavy. Use proper lifting techniques (lift with your legs) to avoid injury.
 - Use 30 - 34 Ah (C20) batteries only. Failure to use the correct battery size and/or voltage may cause damage to your wheelchair and give you unsatisfactory performance.
 - ALWAYS use a battery handle/lifting strap when lifting a battery. It is the most convenient method and assures that the battery acid will not spill. It also helps to prolong the life of the battery.
 - DO NOT tip the batteries. Keep the batteries in an upright position.
 - NEVER allow any of your tools and/or battery cables to contact both battery posts at the same time. An electrical short may occur and serious personal injury or damage may occur.
 - The POSITIVE (+) battery cable MUST connect to the POSITIVE (+) battery terminal, otherwise serious damage will occur to the electrical system.
 - Connect same color connectors to each other (**RED to RED, BLACK to BLACK**).
 - DO NOT remove fuse or mounting hardware from POSITIVE (+) battery cable mounting screw. To replace the fuse, obtain and replace battery harness with fuse.
 - Wheelchairs should be examined during maintenance for signs of corrosion ((by, for example, liquid exposure). Electrical components damaged by corrosion should be replaced IMMEDIATELY.
 - Wheelchairs that are frequently exposed to liquids may require replacement of electrical components more frequently.
-

**Note**

If there is battery acid in the bottom of the battery tray or on the sides of the battery, apply baking soda to these areas to neutralize the battery acid. Before reinstalling the existing or new battery, clean the baking soda from the battery tray or battery being sure to avoid contact with skin and eyes. Determine source of contamination. NEVER install/reinstall a battery with a cracked or otherwise damaged case.

8.7.2 Using the proper batteries

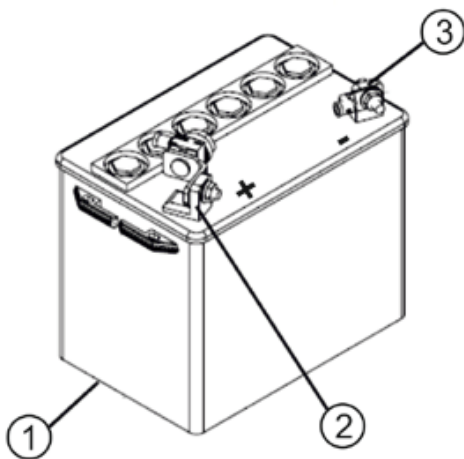

- Place battery (1) on ground/flat surface.
- Visually draw a horizontal and vertical centerline through the middle of battery.
- Position the battery so that the terminals are above the horizontal centerline.
- Visually inspect the battery to ensure the correct position of the **Positive** (2) and **Negative** (3) terminals.



WARNING!

Personal injury or damage may occur in case of wrong terminal configuration.

- *Batteries with terminal configuration as shown below must be used. Batteries that have the reverse terminal configuration must not be used.*
-

8.7.3 Removing/Installing batteries



Requirements:

- 7/16" (6PT) Box Wrench
- Diagonal Cutters



WARNING!

Injury hazard due to discharged acid.

- Always use the battery handle when lifting the battery. It is the most convenient method and assures that the battery acid will not spill. It also helps to prolong the life of the battery.
- Do not tip the batteries. Keep the batteries in an upright position.



Note

If there is battery acid in the bottom of the battery tray or on the sides of the battery, apply baking soda to these areas to neutralize the battery acid. Before reinstalling the existing or new battery, clean the baking soda from the battery tray or battery being sure to avoid contact with skin and eyes. Determine source of contamination.

Never install/reinstall a battery with a cracked or otherwise damaged case.

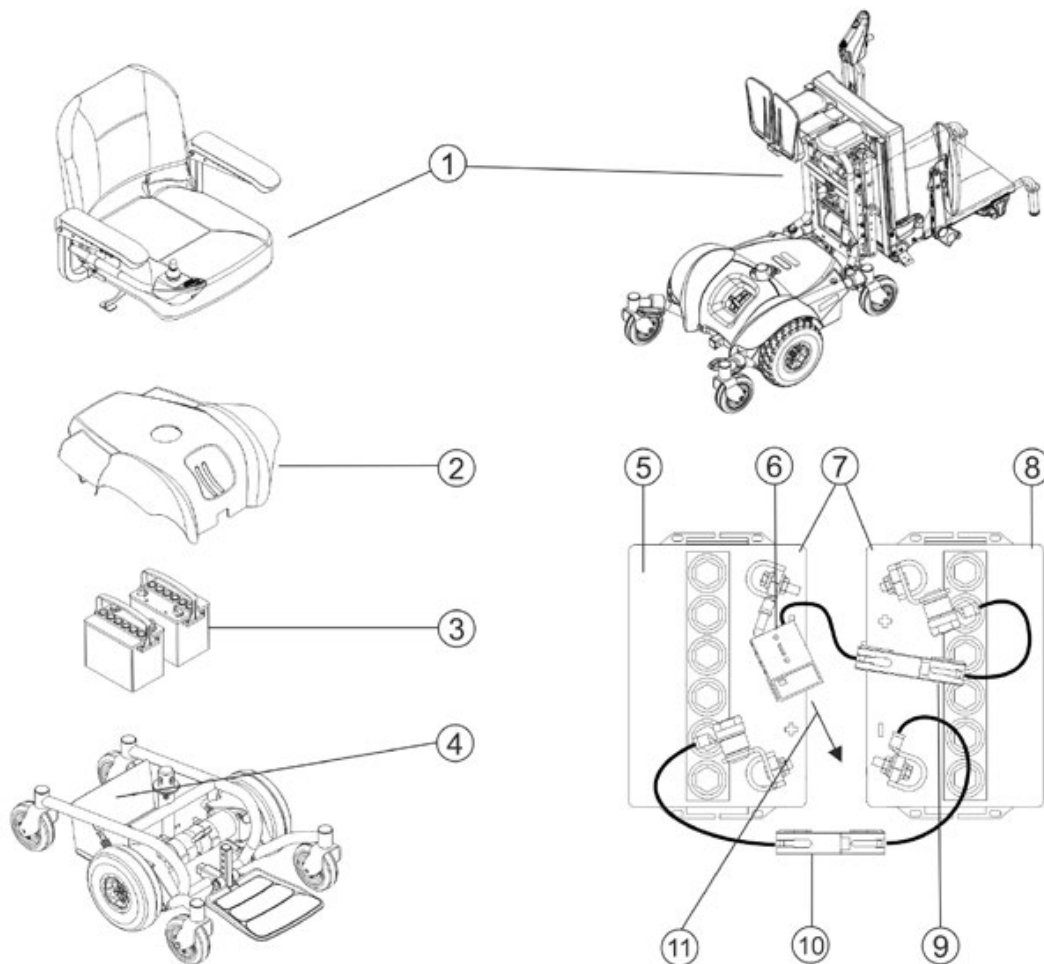

1	Seat (Standard or Captain's) Seat service position (Modulite only)	5	Left battery	9	Black connectors
2	Cover	6	Black connector to power module	10	Red connectors
3	Batteries	7	Batteries 30-34 Ah (C20)	11	Plug into power module
4	Battery tray	8	Right battery		

Removing the battery:

- Verify the joystick ON/OFF switch is in the OFF position and disconnect joystick cable (not shown), refer to chapter 8.2.3.
- Remove the seat (chapter 8.9.1.1) or move the seat into the service position (Modulite seat) as described in chapter 8.9.2.1.
- Remove the top cover, as described in chapter 8.1.1.
- Disconnect the right battery (8) from the power module (6) (**black** connector (9)).
- Disconnect the left battery (5) from the right battery (8) (**red** connector (10) and **black** connector (9)).
- Lift left (5) and right (8) batteries out of the battery tray (4) using the battery handles.

Installing the battery:

- Verify the joystick ON/OFF switch is in the OFF position and disconnect joystick cable, refer to chapter 8.2.3.
- Position the right battery in the battery tray.
- Position the left battery in the battery tray.

**Note**

Ensure that both batteries are properly seated and resting on the battery tray.

- Connect the left battery (5) to the right battery (8) (**red** connector (10) and **black** connector (9)).
- Connect the right battery (8) to the power module (6) (**black** connector (9)).
- Reinstall the top cover, as described in chapter 8.1.1.
- Reinstall the seat, as described in chapter 8.9.1.1/8.9.2.1.
- Connect joystick cable (not shown), as described in chapter 8.2.3.

8.7.4 Connecting/Disconnecting battery cables

8.7.4.1 Connecting battery cables



DANGER: ELECTRICAL HAZARD!

Serious personal injury or damage may occur in case of an electrical short.

- *NEVER allow any of your tools and/or battery cables to contact both battery terminals at the same time.*
 - *Connect same color connectors to each other (**red to red, black to black**).*
 - *DO NOT remove the fuse or mounting hardware from the POSITIVE (+) battery cable mounting screw. To replace the fuse, obtain and replace battery harness with fuse.*
 - *The POSITIVE (+) battery cable MUST connect to the POSITIVE (+) battery terminal; otherwise serious damage will occur to the electrical system.*
 - *The use of rubber gloves is recommended when working with batteries.*
-



DANGER: ELECTRICAL HAZARD!

Serious personal injury or damage may occur in case of wrong terminal configuration.

- *DO NOT remove fuse or mounting hardware from POSITIVE (+) **red** battery cable/mounting screw.*
 - *Battery terminal configuration as shown in the following figure MUST be used. Batteries that have the terminal configuration reversed MUST NOT be used - otherwise serious injury or damage may occur.*
 - *Install protective caps on POSITIVE (+) and NEGATIVE (-) terminals.*
 - *All battery terminal covers (two on the right battery and two on the left battery) MUST be installed prior to use.*
-



IMPORTANT!

Risk of damage to the battery cable.

- *The battery cables MUST be connected to the battery terminals, as shown in following figure (depending on battery type), otherwise damage to the battery cable may result when installing battery terminal caps.*
-

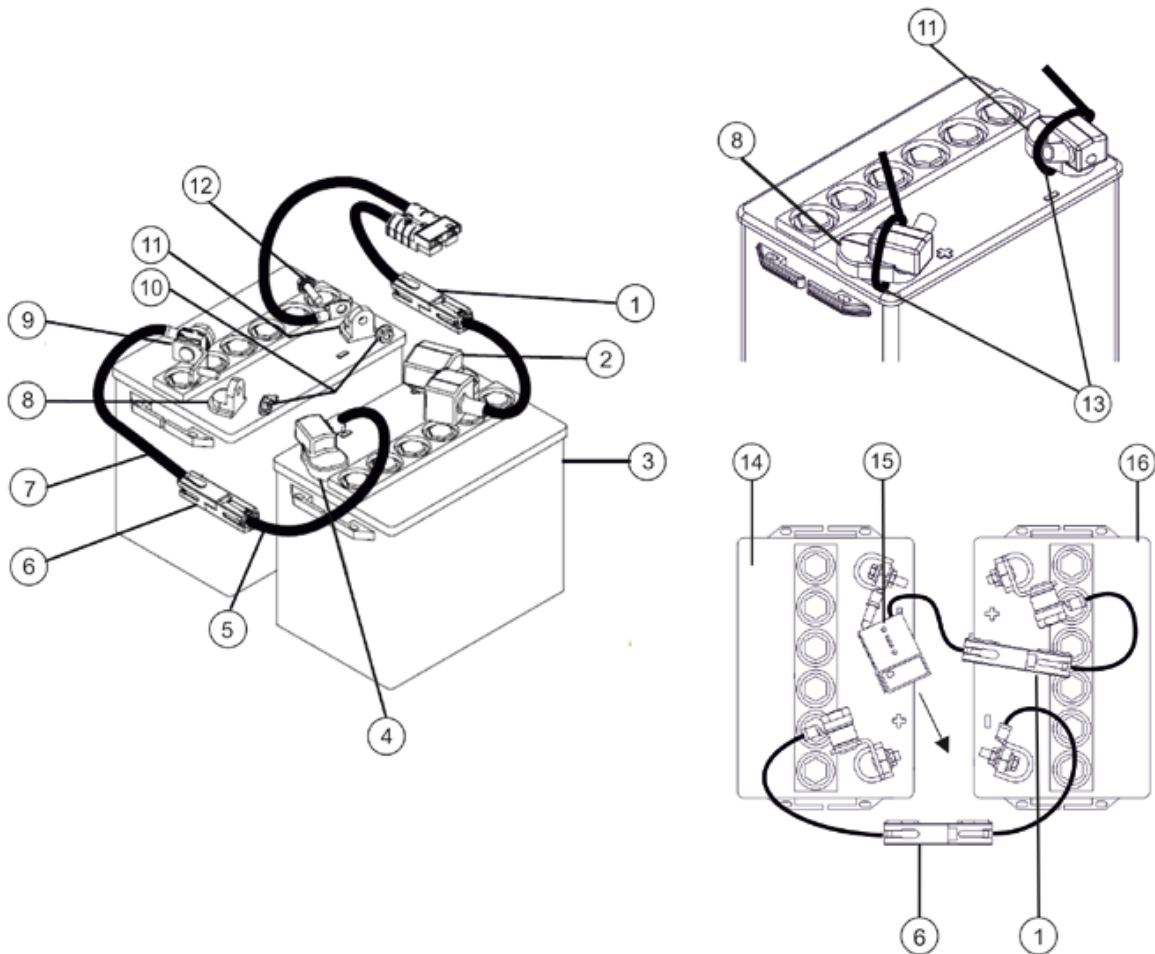

1	Black connectors	6	Red connector	11	Negative (-) battery terminal
2	Positive (+) battery terminal cap	7	Positive (+) battery cable	12	Mounting screw
3	Batteries 30-34 Ah (C20)	8	Positive (+) battery terminal	13	Tie-wraps
4	Negative (-) battery terminal cap	9	L-bracket with mounting screw	14	Left battery
5	Negative (-) battery cable	10	Locknuts	15	Black connector to power module
				16	Right battery

- Connect battery cables to batteries terminals/posts (8) (11):
NEGATIVE (-) **black** battery cable (5) to NEGATIVE (-) battery terminal/post (11) .
POSITIVE (+) **red** battery cable to (7) POSITIVE (+) battery terminal/post (8).
- Secure the battery cables/ring terminals to the battery terminals/posts, **black** to NEGATIVE (-) and **red** to POSITIVE (+), with the provided 1/4-20 x 5/8"-inch (6,35 mm x 15,88 mm) hex flange screw and hex flange locknut. Securely tighten.
- Verify all battery cables/ring terminals are correctly installed and securely tightened.
- Slide terminal caps (2) (4) down battery cables (5) (7) and onto battery clamps.
- Secure each terminal cap in place with a tie-wrap (13) (use tie-wraps 11-1/2-inches (292,1 mm) long).
- Position the batteries into the wheelchair, as described in chapter 8.7.3.



Note

New battery (ies) MUST be fully charged before using, otherwise the life of the battery(ies) will be reduced.

8.7.4.2 Disconnecting battery cables



DANGER: ELECTRICAL HAZARD!

Serious personal injury or damage may occur in case of an electrical short.

- The use of rubber gloves is recommended when working with batteries.
- NEVER allow any of your tools and/or battery cables to contact both battery terminals at the same time.



Requirements:

- Wire cutters
- Needle nose pliers
- 11 mm open-ended spanner

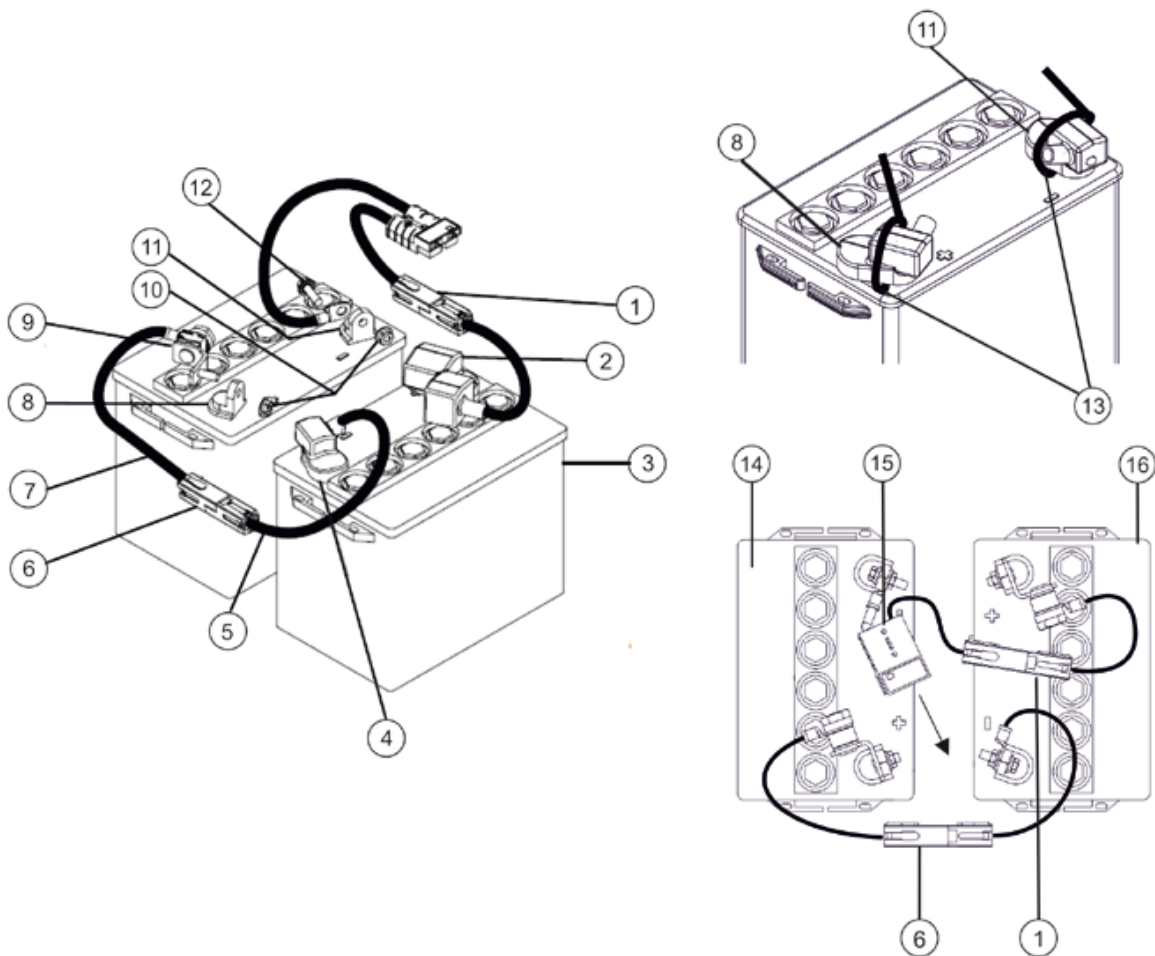

1	Black connectors	6	Red connector	11	Negative (-) battery terminal
2	Positive (+) battery terminal cap	7	Positive (+) battery cable	12	Mounting screw
3	Batteries 30-34 Ah (C20)	8	Positive (+) battery terminal	13	Tie-wraps
4	Negative (-) battery terminal cap	9	L-bracket with mounting screw	14	Left battery
5	Negative (-) battery cable	10	Locknuts	15	Black connector to power module
				16	Right battery

- Remove the seat, as described in chapter 8.9.1.1.
- Remove the batteries, as described in chapter 8.7.3.
- Cut the tie-wrap (13) that secures the battery terminal cap (2) (4) in place.
- Slide terminal caps (2) (4) up onto the battery cables (5) (7).
- Disconnect POSITIVE (+) **red** battery cable (7) from the POSITIVE (+) battery terminal/post (8).
- Disconnect NEGATIVE (-) **black** battery cable (5) from NEGATIVE (-) battery terminal/post (11).

8.7.5 Correct handling of damaged batteries



WARNING: BURN DANGER!

Injury hazard due to discharged acid.

- *Always wear acid-proof protective gloves when handling batteries.*
- *Always wear protective goggles when handling batteries.*



What to do if acid is discharged:

- *Always take clothing which has been soiled by or dipped in acid off immediately!*
- *Rinse any areas of your skin which has come into contact with battery acid off immediately with plenty of water!*

If contact with eyes is made:

- *Rinse the affected eye under running water for several minutes! You should also consult an eye specialist immediately afterwards!*



Requirements:

- protective goggles
- acid-proof gloves
- acid-proof transport container

- If handling damaged batteries, always wear suitable protective clothing.
- Always deposit damaged batteries in suitable acid-proof containers immediately after removal.
- Only transport damaged batteries in suitable acid-proof containers.
- Always wash any objects which were contacted by acid in plenty of fresh water.



Always dispose of used or damaged batteries correctly

Used and damaged batteries will be taken back by your medical equipment supplier or Invacare®.

8.8 Cables

8.8.1 Cable routing



WARNING!

Cables must be secured to the wheelchair frame and/or base with tie-wraps after servicing is complete. Failure to follow the warnings and instructions below could result in injury to the users, attendants and/or bystanders and/or damage to the wheelchair.

- Cables **MUST** be secured so there are no loops of excess cable extending away from the wheelchair. Bundle all excess cable together and secure with a tie-wrap. It may also be necessary to secure these bundles to the frame and/or base.
- **ALWAYS TEST** all wheelchair functions after securing the cables to be sure cables do not get pinched or crushed during operation of the wheelchair.



Note

Motors not shown for clarity. The motor cables are routed out the hole located at the back of the battery box.

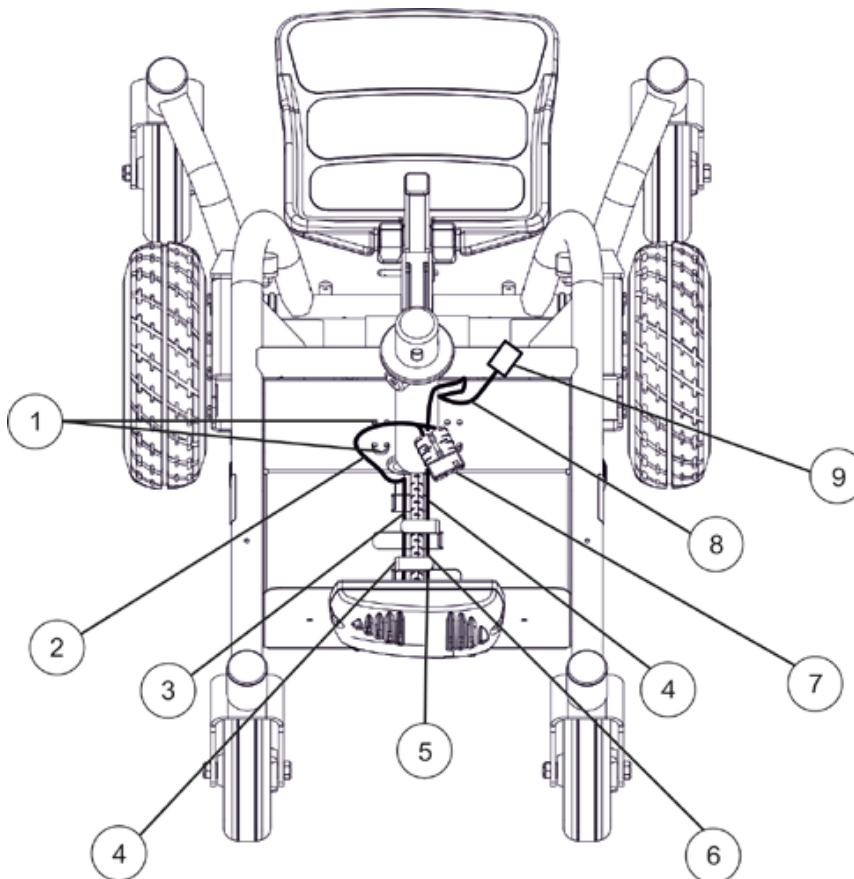

1	Motor cable tie wraps	4	Tab	7	Battery connector
2	Battery cable	5	Power module	8	Tie wrap here
3	Motor cable	6	Joystick cable	9	Joystick connector

8.8.2 Checking the cables

- Switch the electronics OFF on the remote.
- Remove the rear and top cover as described in chapter 8.1.1 and chapter 8.1.3.
- Move the seat into the service position (Modulite seat) as described in chapter 8.9.2.1
- Check all cables for visible damage, crushing points or abrasion points.
- Replace damaged cables.
- Pull on each plug carefully. The plug must not come out of its socket when pulled on lightly.
- If a plug is loose, apply slight pressure to push the plug into the socket. The plug must snap in place securely.
- Check that the plug is firmly attached to its socket.
- Remove the batteries as described in chapter 8.7.3.
- Check the battery cables for visible damage, crushing points or abrasion points.
- Replace damaged cables.
- Assemble all parts again in reverse order.
- The last step is to test all functions of the vehicle.

8.9 Seat system

8.9.1 Captain's seat/standard seat



WARNING!

After any adjustments, repair or service and before use, make sure that all attaching hardware is tightened securely - otherwise injury or damage may result.

- Before performing any maintenance, adjustment or service verify that ON/OFF switch on the joystick is in the OFF position.

8.9.1.1 Removing/Installing the seat assembly

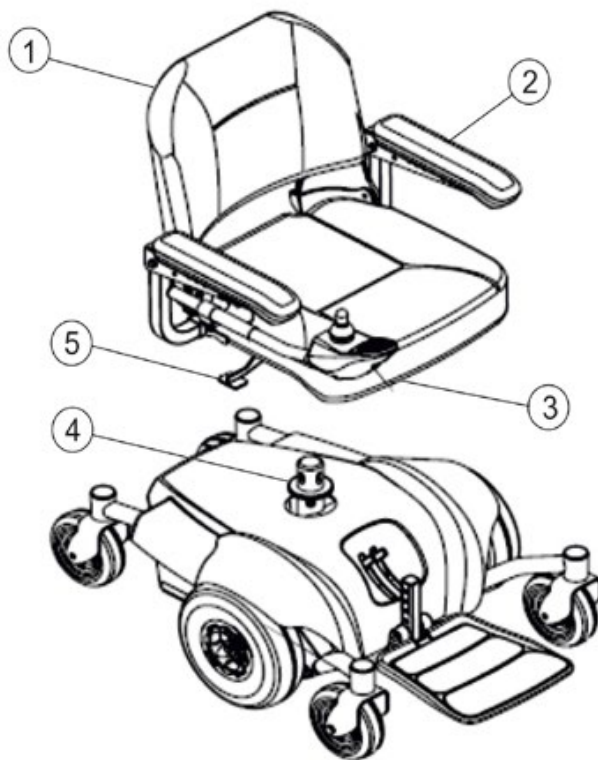

Removing the Seat Assembly:

- Disconnect the joystick, as described in chapter 8.2.3.
- Pull the release lever to fold down the seat back (1).
- Pull the seat lever (5) up and lift the seat assembly (2) up and away from the seat post (4).

Installing the Seat Assembly:

- Align the seat pivot (3) with the seat post (4).
- Pull the seat lever (5) up and lower the seat assembly (2) on the seat post (4).



Note

If necessary, slightly twist seat assembly back and forth to lock it in place.

- Release the seat lever (5).
- Pull the seat assembly (2) up to ensure that it is locked in place.
- Connect the joystick, as described in chapter 8.2.3.

8.9.2 Modulite Seat

8.9.2.1 Moving the seat into the service position

It is necessary to move the seat into the service position or to remove it for maintenance purposes or if the batteries have to be removed.



CAUTION: Risk of crushing!

The seat is very heavy. Risk of injury to hands and feet!

- Use proper lifting techniques.

Risk of injury due to uncontrolled movement of the wheelchair!

- Switch the vehicle's power system off (ON/OFF key).
- Engage the drive motors.
- Secure the vehicle against rolling away by pressing the parking brake down.



CAUTION: Risk of crushing!

The seat has no stopper to prevent it from falling over backwards when being unlocked.

- Be careful when unlocking the seat.
- Pay attention to your hands and feet.

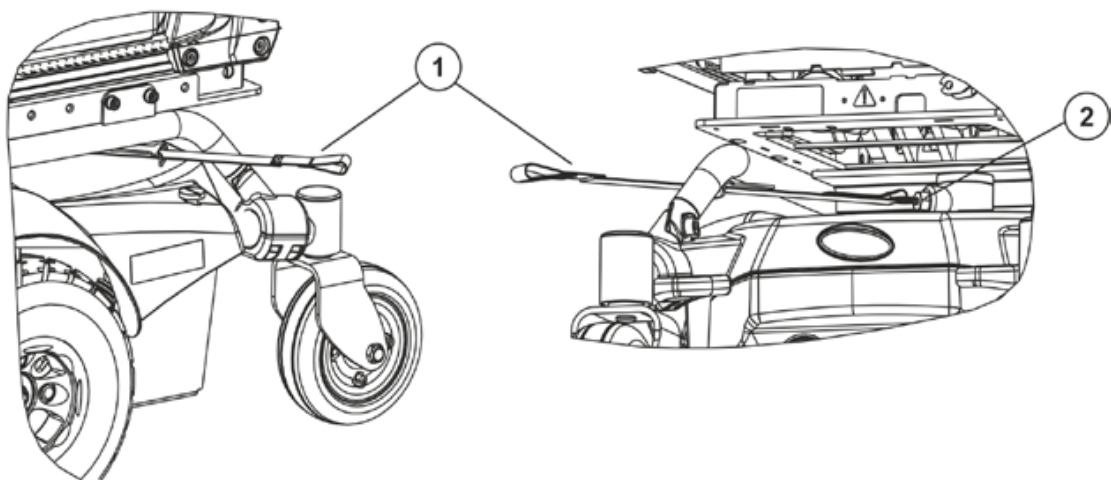

- Pull the belt webbing (1) under the seat on the centre column (2) to unlock the seat.
- Carefully fold the seat backwards.

The seat is now in the service position.

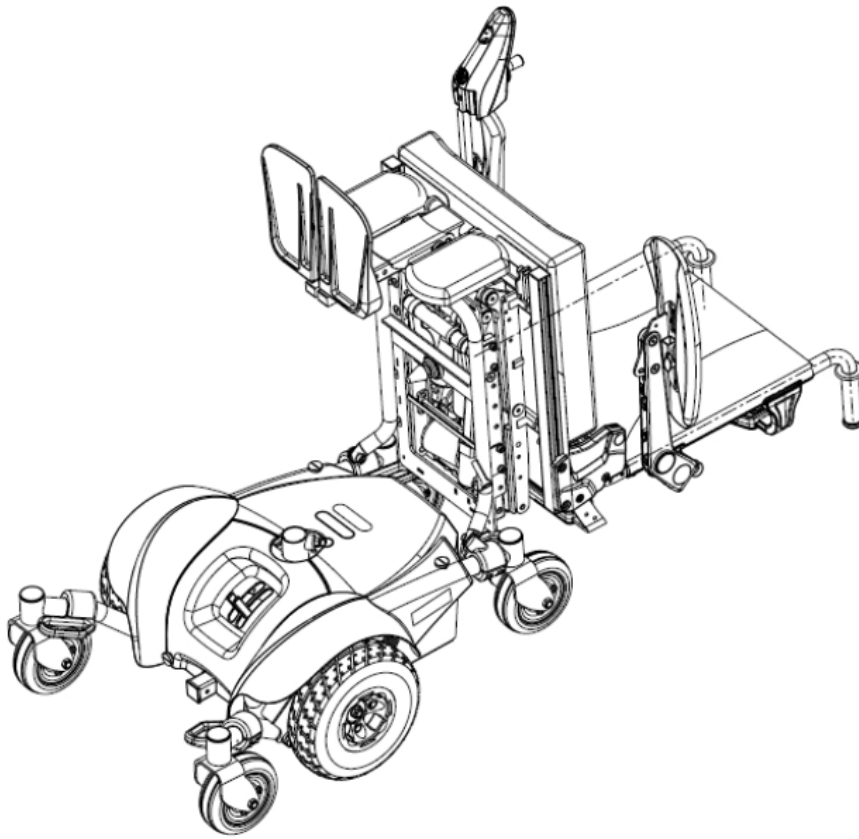

8.9.2.2 Replacing the seat angle adjustment actuator



Requirements:

- Screwdriver, flat, width 6 mm
- 13 mm open-ended wrench (2x)

- Remove legrests.
- Switch the electronics OFF on the remote.
- Disconnect the actuator cable from the cable harness.

Variant actuator - seat angle adjustment:

- Bottom fixing bolt (3) with nut (4) –
Loose the nut with the open-ended wrenches.
Remove the nut and bolt.
- Top fixing bolt (2) secured with snap rings (1) –
Remove a snap ring using a screwdriver and
remove the bolt.
- Pull the actuator out.
- Insert a new actuator.
- Reassembly takes place in the reverse order.
- Connect the actuator cable to the cable harness.
- To complete, check all I angle adjustment
functions.

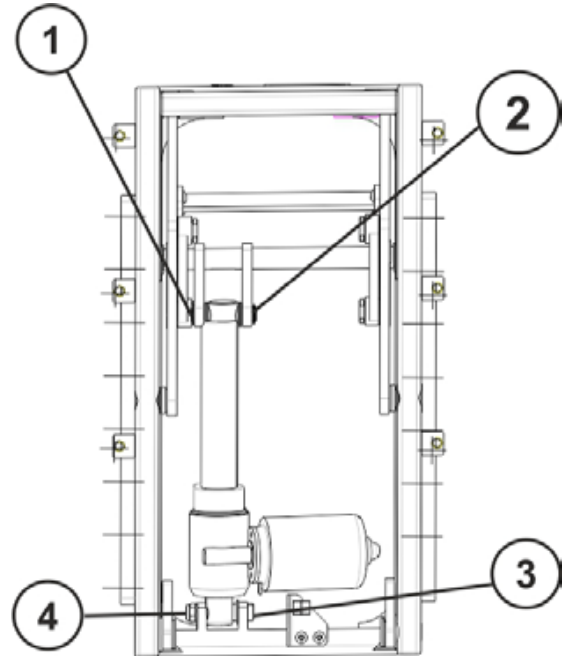

Variant seat angle adjustment actuator in the lifter/seat angle adjustment module:

- Bottom fixing bolt (3) with slot –
Loosen the fixing bolt with a screwdriver.
Remove the bolt.
- Top fixing bolt (2) secured with snap rings (1) –
Remove a snap ring using a screwdriver and
remove the bolt.
- Pull the actuator out.
- Insert a new actuator.
- Reassembly takes place in the reverse order.
- Connect the actuator cable to the cable harness.
- To complete, check all angle adjustment functions.

8.9.2.3 Replacing the lifter actuator



Requirements:

- Flat screwdriver

- Remove legrests.
- Run the lifter up to if possible.
- Switch the electronics OFF on the remote.
- Secure the seat.
- Pull the plug from the actuator.
- Bottom fixing bolt (1) secured with snap rings – Remove a snap ring using a screwdriver and remove the bolt.
- Top fixing bolt (2) with slot – Loosen the fixing bolt with a screwdriver. Remove the bolt.
- Replace actuator.
- Reassembly of the actuator takes place in the reverse order.
- Connect the plug of the actuator cable to the actuator.
- To complete, check all angle adjustment functions.

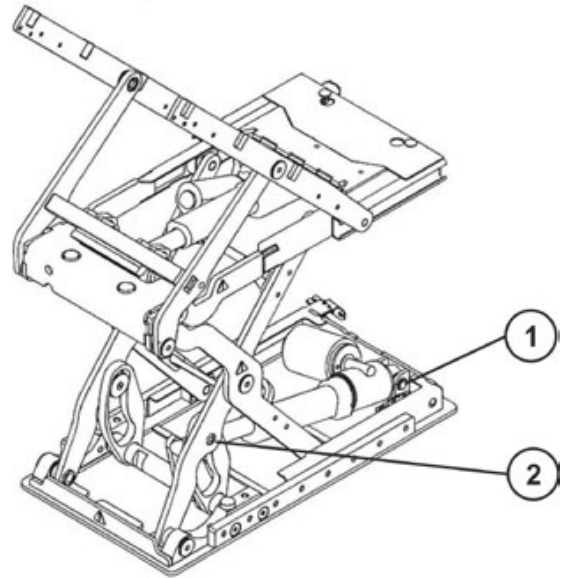

If the lifter cannot be raised, a cover can be removed from the upper rear side of the module. This way it is possible to reach the lower fixation bolt of the actuator.

8.9.2.4 Replacing the lifter / seat angle adjustment module



Note

Replacement of the seat angle adjustment module is performed in the same manner.



CAUTION: Risk of crushing!

The seat is very heavy. Risk of injury to hands and feet!

- Use proper lifting techniques



Requirements:

- 3 mm Allen key
- 5 mm Allen key
- T25 Torx wrench
- T40 Torx wrench
- Side cutting pliers
- Cable ties

- Remove legrests.
 - Tilt the seat angle adjustment completely to the rear if possible.
 - Switch the electronics OFF on the remote.
 - Remove the backrest cushion.
 - Loosen and remove the screws, which secure the middle seat plate (A) with a 3 mm Allen key.
 - Remove the middle seat plate (B).
 - Loosen and remove the screws on both sides, which secure the lateral seat plates (C) with a 3 mm Allen key.
 - Remove the lateral seat plates (D).
- or**
- Remove the seat cushion.
 - Loosen and remove the screws on both sides, which secure the sling seat (A) with a T25 Torx wrench.
 - Remove the sling seat (B).

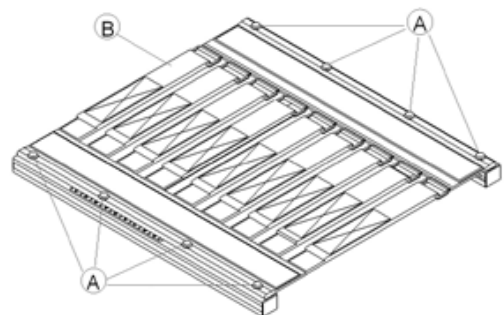
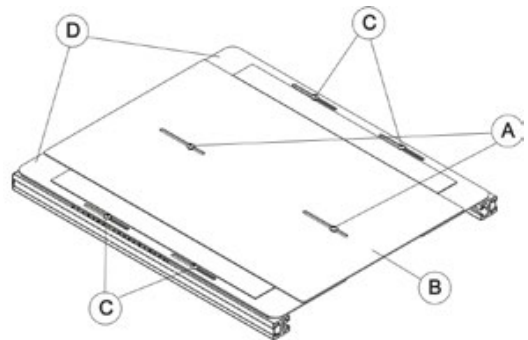

- Remove the seat frame by removing the screws (1) with a T40 Torx wrench.

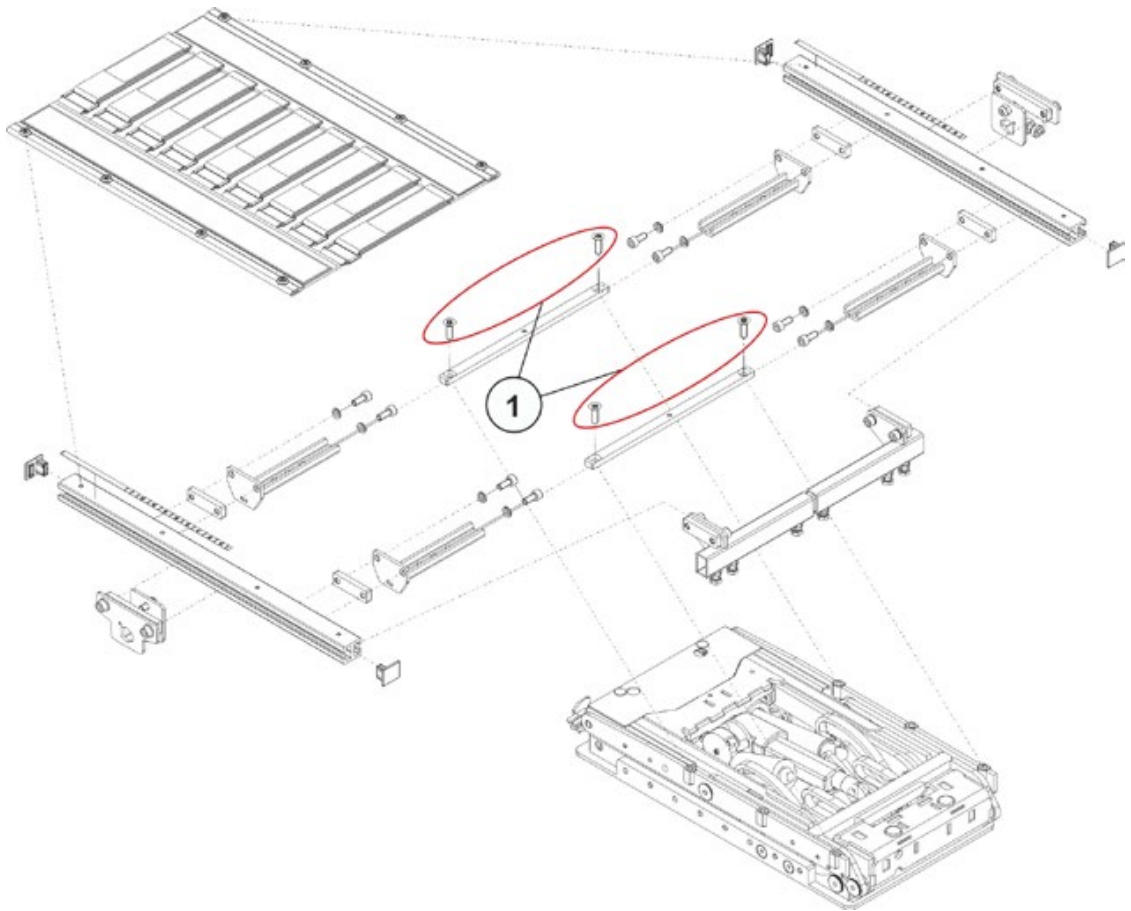

- Disconnect the actuator cable and microswitch cable from the cable harness.

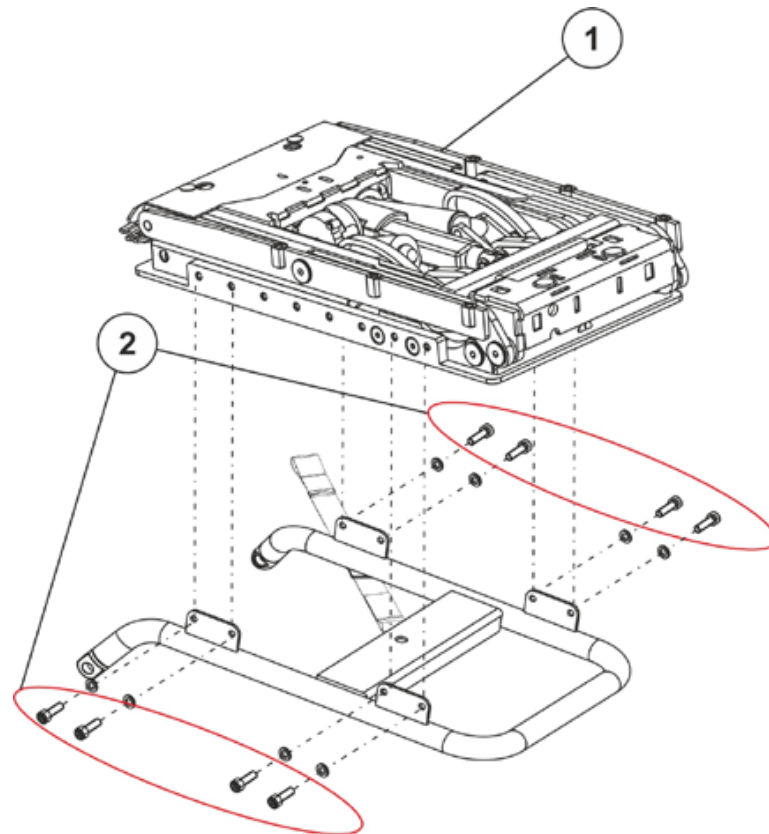

- Loosen and remove the screws (2) including the washers with a 5 mm Allen key.
- Lift the module of the seat angle adjustment (1) from the frame and replace it.
- Reassembly takes place in the reverse order.

**Note**

Make sure that all screws, washers and nuts are reassembled in the correct order and securely tightened during assembly.

- When installing the seat, pay attention to its heavy weight!
- To complete, check all seat tilting functions.

8.9.2.5 Replacing the backrest actuator

Dismantling the backrest actuator:

- Pull the cable off directly where it is connected to the actuator (1).
- Detach the bracket of the actuator at the top and bottom; to do this, slide the bolts (3) to the side using the lever (4) and tilt the actuator (1) out of the backrest clamp (2).
- Replace actuator.

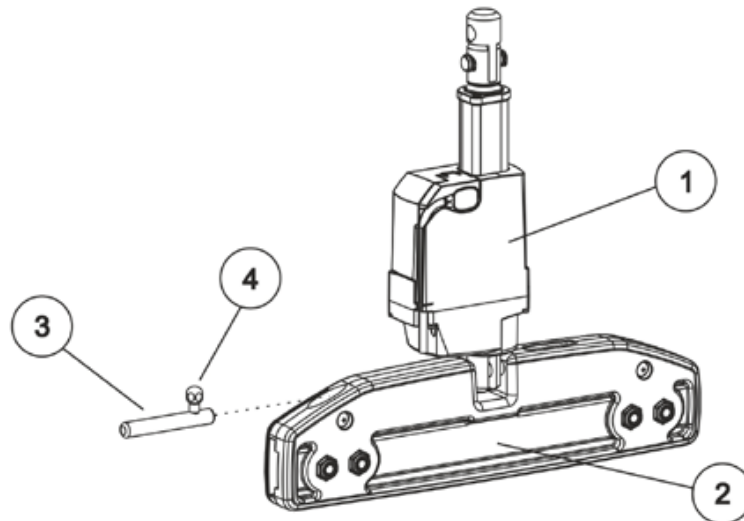

Refitting the backrest actuator:

- Assemble the parts in the reverse order.

8.9.2.6 Replacing the seat support (without lifter or seat angle adjustment modules)



Note

This chapter deals with replacing the seat support for a seat without lifter or seat angle adjustment modules. Please proceed as described in chapter 8.9.2.4 to replace lifter or seat angle adjustment modules.



CAUTION: Risk of crushing!

The seat is very heavy. Injury hazard to hands and feet!

- Pay attention to the hand and feet
- Use proper lifting techniques



Requirements:

- 3 mm Allen key
- 10 mm open-ended wrench
- T25 Torx wrench
- T40 Torx wrench
- Side cutting pliers
- Cable ties

- Remove legrests.
 - Switch the electronics OFF on the remote.
 - Remove the backrest cushion.
 - Loosen and remove the screws, which secure the middle seat plate (A) with a 3 mm Allen key.
 - Remove the middle seat plate (B).
 - Loosen and remove the screws on both sides, which secure the lateral seat plates (C) with a 3 mm Allen key.
 - Remove the lateral seat plates (D).
- or**
- Remove the seat cushion.
 - Loosen and remove the screws on both sides, which secure the sling seat (A) with a T25 Torx wrench.
 - Remove the sling seat (B).

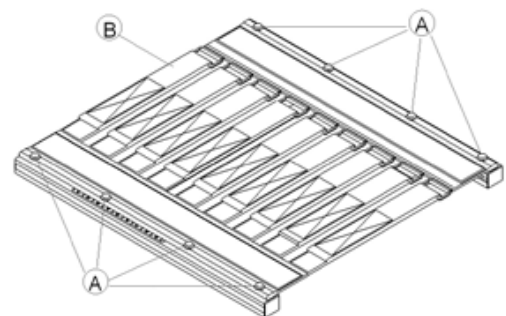
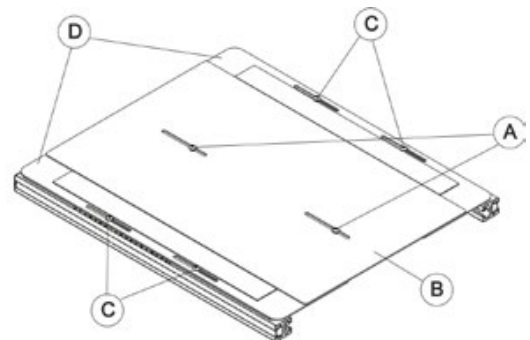

Uninstalling the seat support (adjustable seat / simple seat)**Requirements:**

- 6 mm Allen key
- 13 mm open-ended wrench

The following figure shows the seat support with the adjustable seat plate.

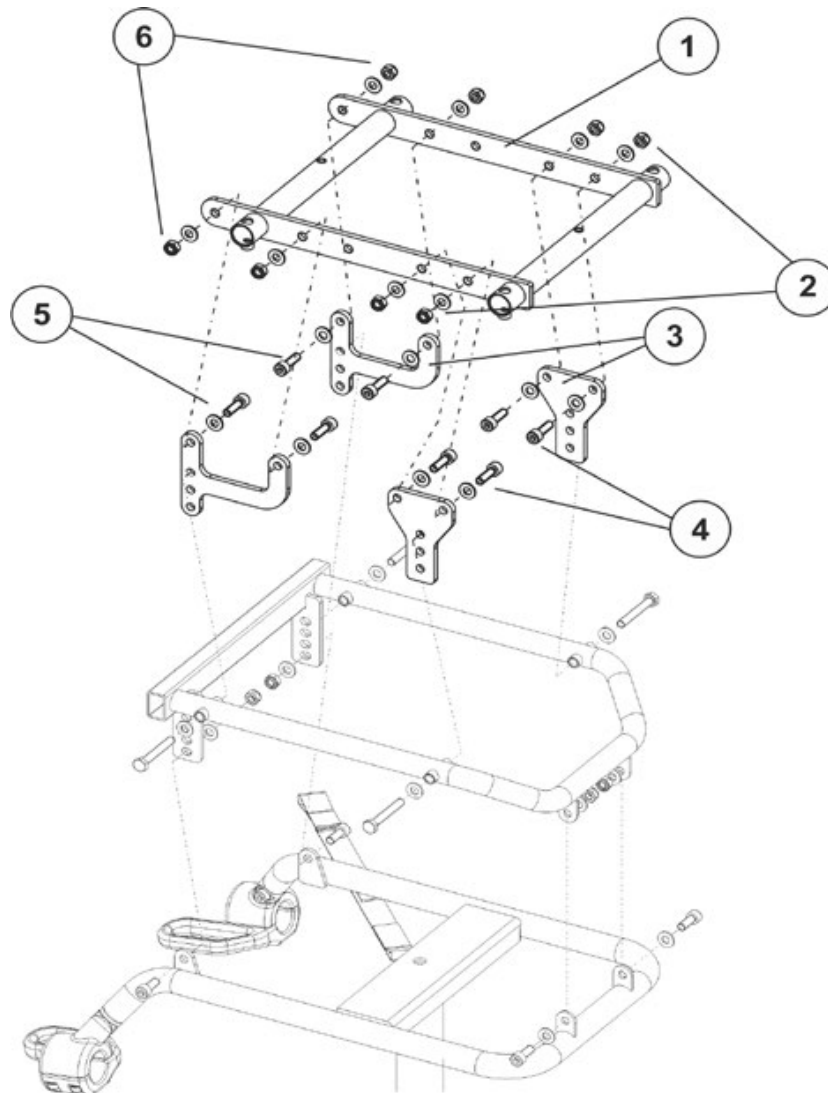

- Remove the seat plate or sling seat, see chapter 8.10.1.
- Loosen the four Allen screws (4) (5) in the front and rear and the self-locking nuts (2) (6) including the washers with a 13 mm open-ended wrench and a 6 mm Allen key.
- Remove the seat support (1) from the seat adapter (3).

Installing the seat and seat support

- Assemble all parts in reverse order.
-

**Note**

Make sure that all screws, washers and nuts are reassembled in the correct order and securely tightened during assembly.

- When installing the seat, pay attention to its heavy weight!
- Tighten the screws to a torque of 25 Nm.
- Check all functions of the vehicle and go for a test drive.

8.9.3 Backrest unit - Modulite

8.9.3.1 Replacing the standard backrest

**Requirements:**

- 5 mm Allen key

Dismantling the backrest unit:

- Remove the backrest cushion.
- Loosen the fixation lever (2) of the backrest tube.
- Remove the backrest tube.

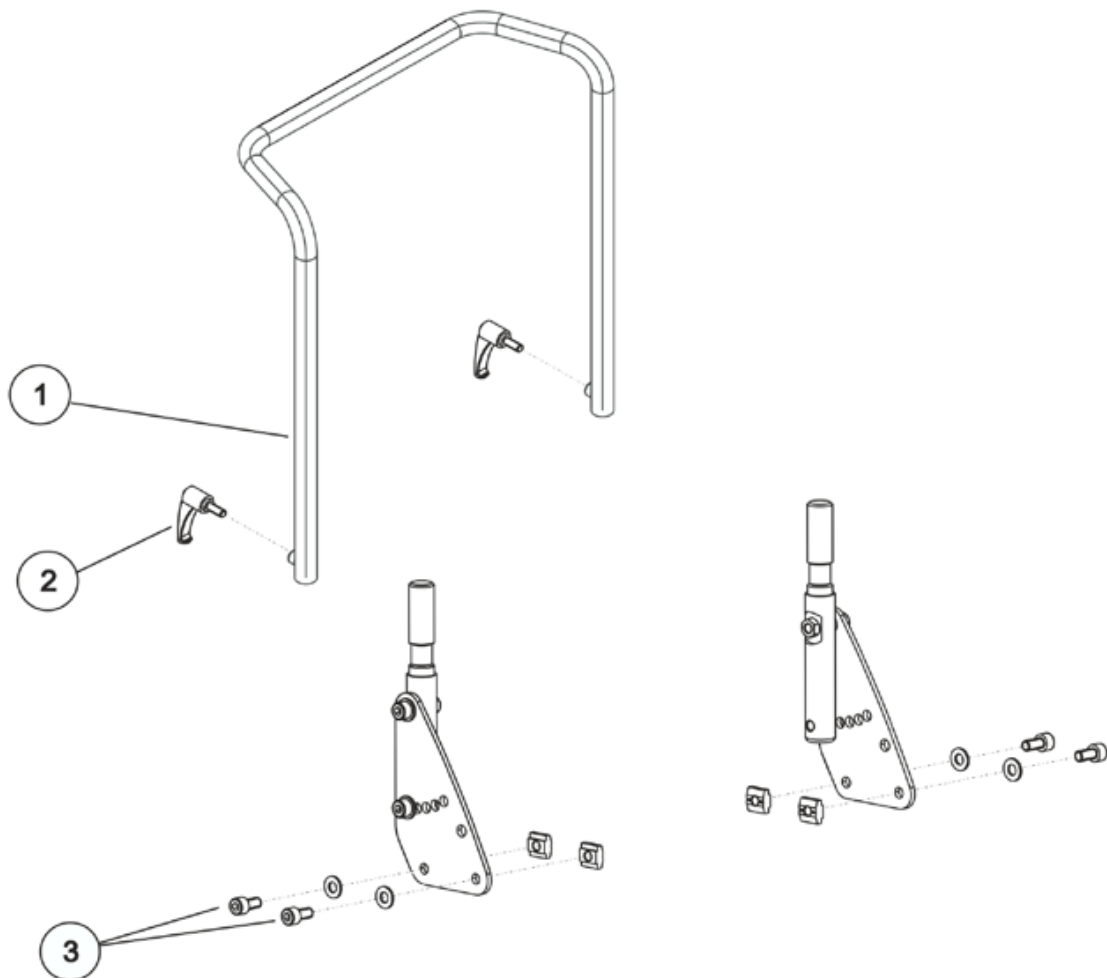

- Use the Allen key to loosen and remove the hexagon socket head screws (3) including the nuts and washers on the left and right side of the chair.

Refitting the backrest unit:

- Replace the parts in the reverse order.
- To conclude, you should always carry out a trial run to test the vehicle functions.

8.9.3.2 Replacing the backrest mounting bracket



Requirements:

- 5 mm Allen key

Dismantling the backrest unit:

- Remove the backrest cushion.
- Loosen the fixation levers (2) of the corresponding backrest tube (1), depending on the version.
There are two versions:
(2) - for the manual backrest
(3) - for the electrically adjustable backrest
- Remove the backrest tube.

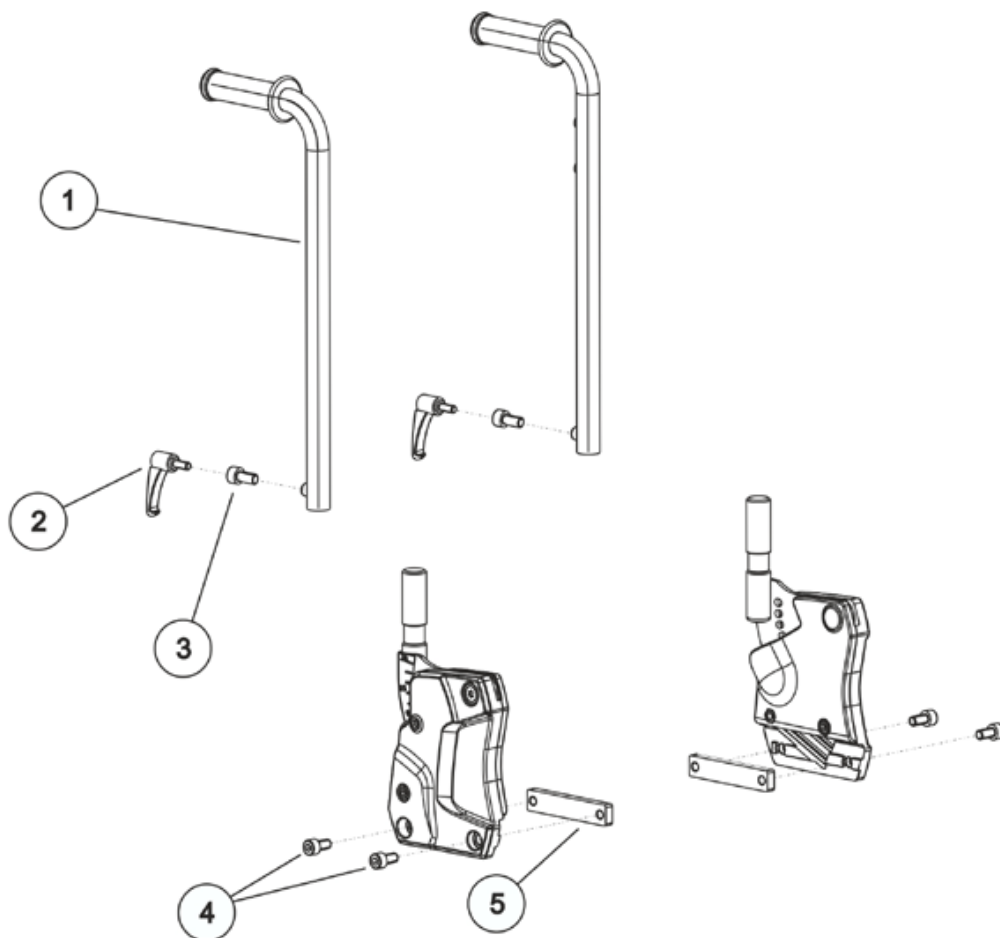

- Loosen and remove the two hexagon socket head screws (4) to the sliding block (5) on the left and right side of the chair.

Refitting the backrest unit:

- Replace the parts in the reverse order.
- To conclude, you should always carry out a trial run to test the vehicle functions.

8.10 Adjusting the seat width/ backrest width (Modulite)

8.10.1 Adjusting the seat width

You can only adjust the seat width for the adjustable seat plate or for the adjustable sling seat.

The sling seat is available in two widths:

- for a seat width of 38-43 cm and
- for a seat width of 48-53 cm.

When modifying the seat width, the backrest width must also be correspondingly adapted. See chapter 8.10.2.



Requirements:

- 3 mm Allen key
- 5 mm Allen key
- 13 mm open-ended wrench
- T25 Torx wrench
- T40 Torx wrench

- Remove the backrest cushion.
- Remove the backrest from the backrest mounting bracket. See chapter 8.9.3.
- Loosen and remove the screws, which secure the middle seat plate (A) with a 3 mm Allen key.
- Remove the middle seat plate (B).
- Loosen and remove the screws on both sides, which secure the lateral seat plates (C) with a 3 mm Allen key.
- Remove the lateral seat plates (D).

or

- Remove the seat cushion.
- Loosen and remove the screws on both sides, which secure the sling seat (A) with a T25 Torx wrench.
- Remove the sling seat (B).

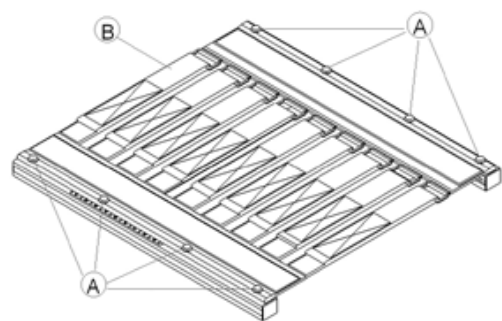
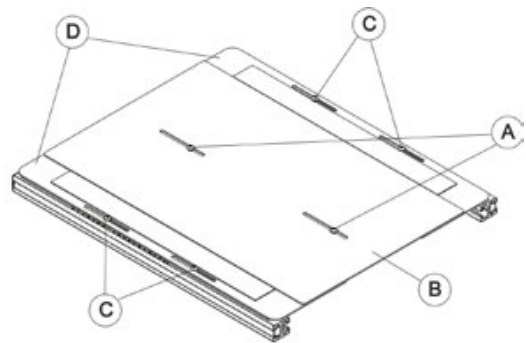

- Loosen and remove the screws of the seat frame adjustment (A) with a T40 Torx wrench.
- Loosen and remove the screws of the fixation of the legrest mounting brackets (B).

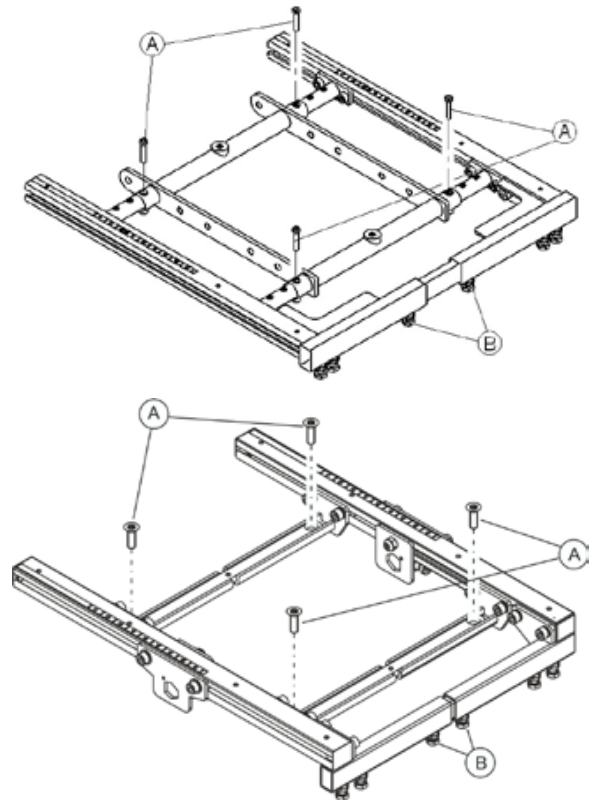

- Adjust the seat frame and the legrest fixation to the desired width according to the following illustrations and tables:

Seat frame:

Screw position	Seat width
A	530 mm
B	480 mm
C	430 mm
D	380 mm

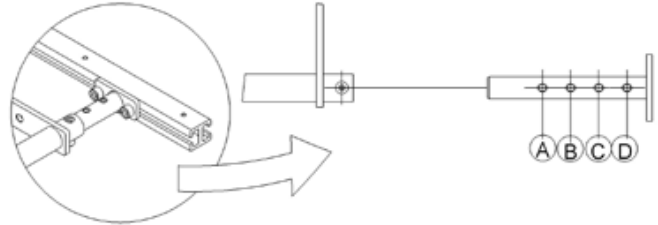

Leg supports connection:

Screw position	Seat width
A	380 mm
B	430 mm
C	480 mm
D	530 mm

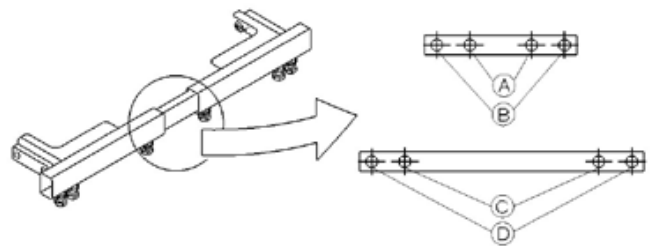

Note

When switching from 430 mm to 480 mm and the other way around, the fixation of the legrests must be replaced.

- Reposition the screws and tighten them again.
- Install the seat plate or the sling seat.
- Reposition the seat cushion.

8.10.2 Adjusting the backrest width

The backrest width is adjusted by performing the following tasks:

- Adjust the backrest tube.
- Adjust the backrest:
 - Sling backrest, as described in chapter 8.11.1.
 - Flex3 backrest, as described in chapter 8.10.3.
- Replace the backrest cushion (these are available in various widths).

When modifying the backrest width, the seat width must also be correspondingly adapted. Please see chapter 8.10.1.



Requirements:

- 3 mm Allen key
- 5 mm Allen key
- 13 mm open-ended wrench

The screw position for the backrest width, refer to the table:

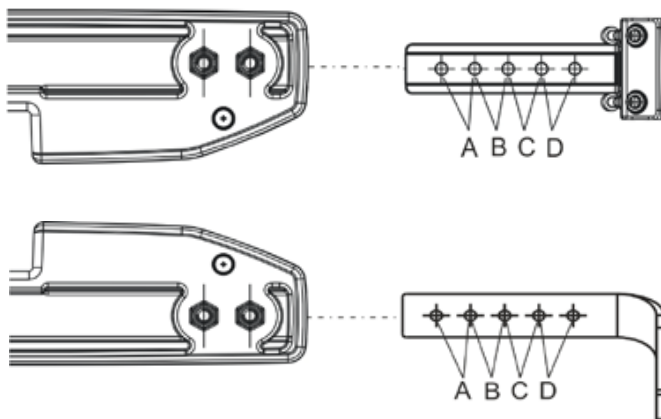

Screw position	Seat width
A	530 mm
B	480 mm
C	430 mm
D	380 mm

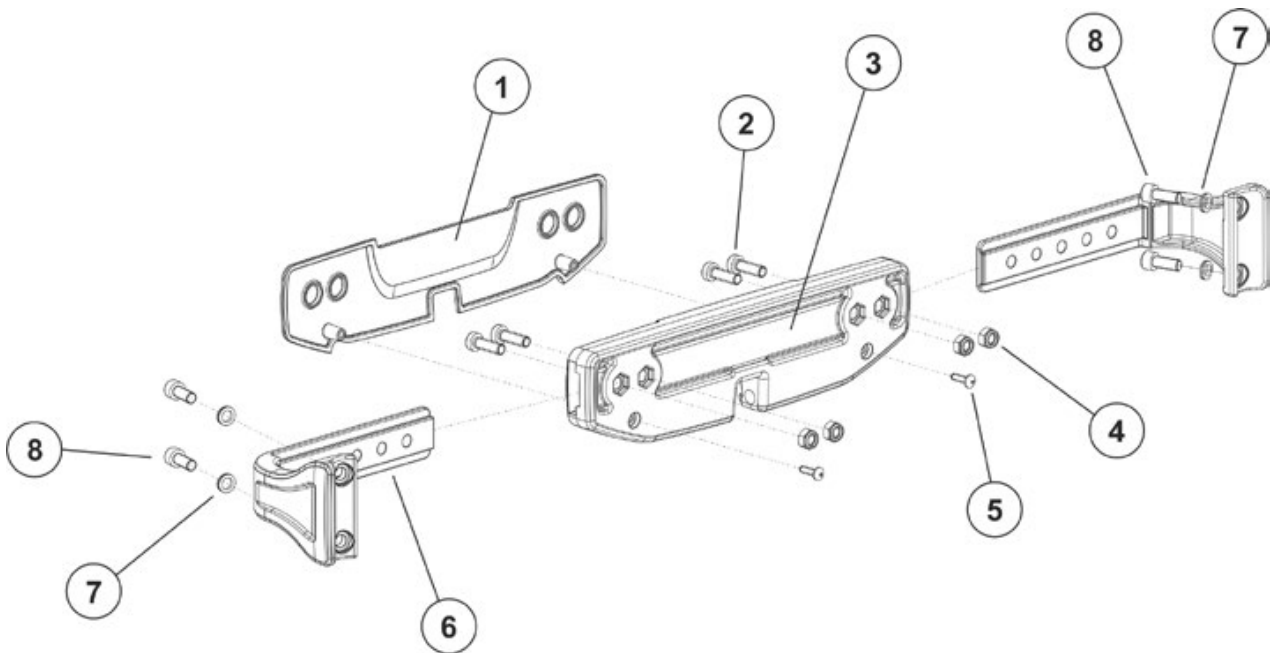

- Remove the backrest cushion.
- Loosen the straps of the sling backrest or remove the Flex3 backrest.
- Loosen and remove both screws (5) of the actuator fixation bracket.
- Remove the cover of the actuator fixation bracket.
- Loosen and remove the screws and nuts (2, 4) on the upper and lower actuator fixation bracket on both sides.
- Adjust the backrest fixation (6) for the new backrest width according to the table on page 82.
- Insert the screws (2) through the cover of the actuator fixation bracket and the corresponding holes of the backrest fixation to the actuator fixation.
- Fasten these with the nuts (4).
- Reposition the cover of the actuator fixation bracket.
- Insert and tighten the screws (5) again.
- Adjust the straps of the sling backrest to the new width or install the adjusted Flex 3 backrest.
- Install the backrest cushion.
- Perform a function check of the chair.

8.10.3 Adjusting the Flex3 backrest



Requirements:

- Phillips screwdriver
- 5 mm Allen key

- Remove the front lateral plates (2 and 4) from the backrest (1) by loosening and removing the five hexagon socket head screws (3).

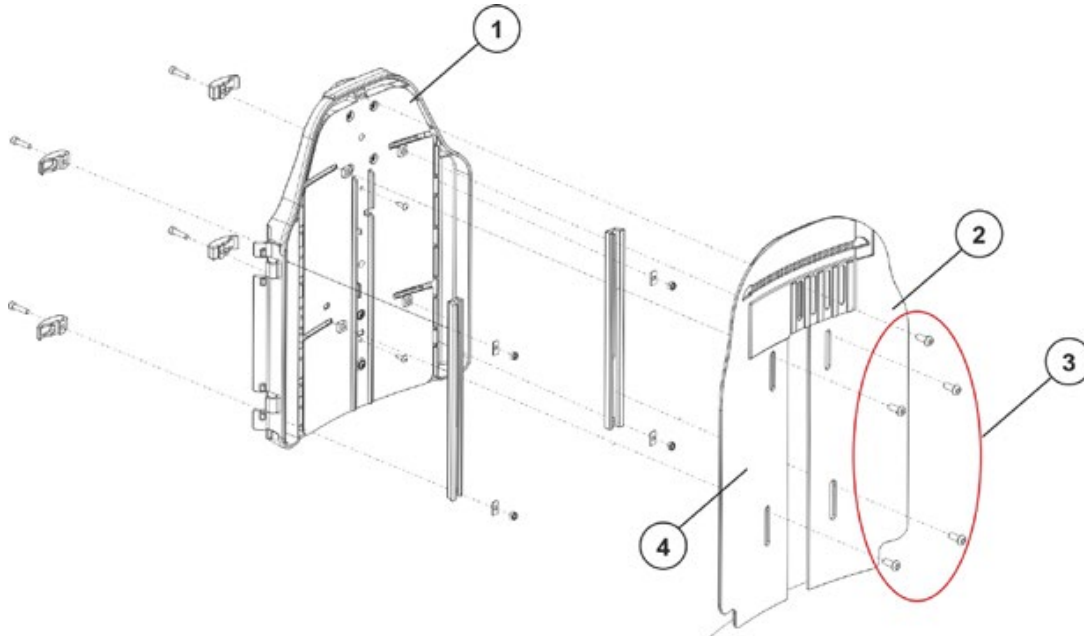

- Remove both Phillips screws (A) on the middle plate.

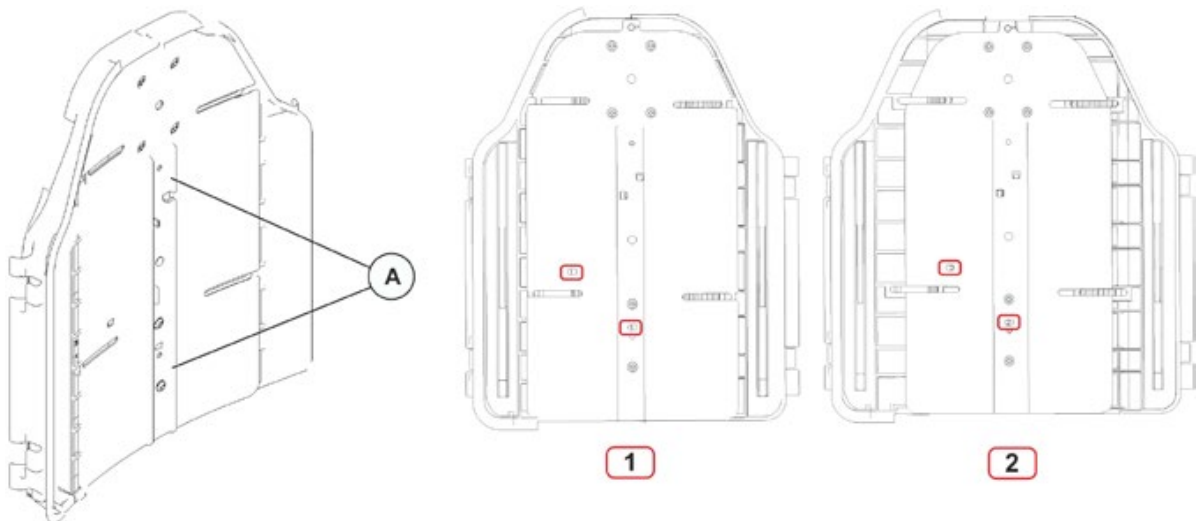

- Shift the position of the rear plate halves (three settings are possible using the drill holes).
 - **Before** pulling the Flex3 backrest apart, a "1" will be visible in the small, rectangular cut-out.
 - **After** pulling the Flex3 backrest apart, a "2" will be visible in the small, rectangular cut-out.
- Re-insert the two screws (A) into the middle plate.
- Fasten the front lateral plates (2 and 4) again.

8.11 Backrest unit - Standard

8.11.1 Adjusting sling backrest (standard seat)

The sling backrest can be individually adapted to the user's back shape.

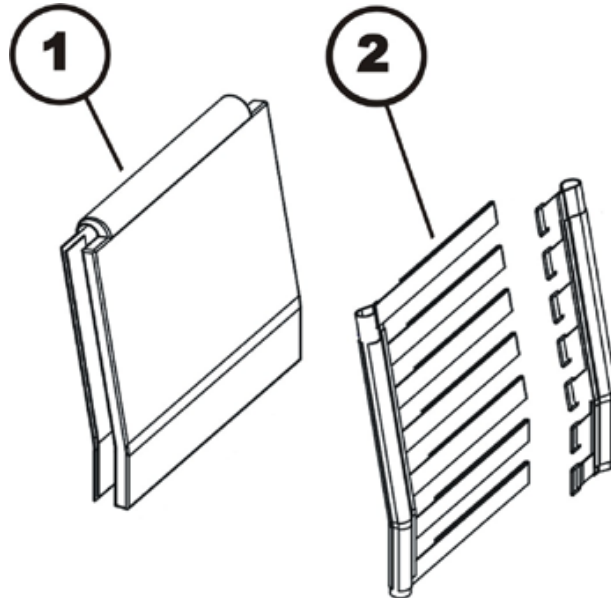

- Pull the front and rear faces of the backrest upholstery (1) apart and remove. The backrest upholstery front and rear faces are held together using Velcro fastenings.
- Open the backrest belt (2) Velcro fastenings and adjust to the required length.
- Reattach the backrest upholstery and fix with Velcro fastenings.

8.11.2 Replacing the standard backrest

Requirements:

- TX30 Torx wrench with T-handle
- 5 mm Allen key
- 10 mm open-ended wrench
- 2 x 13 mm open-ended wrench

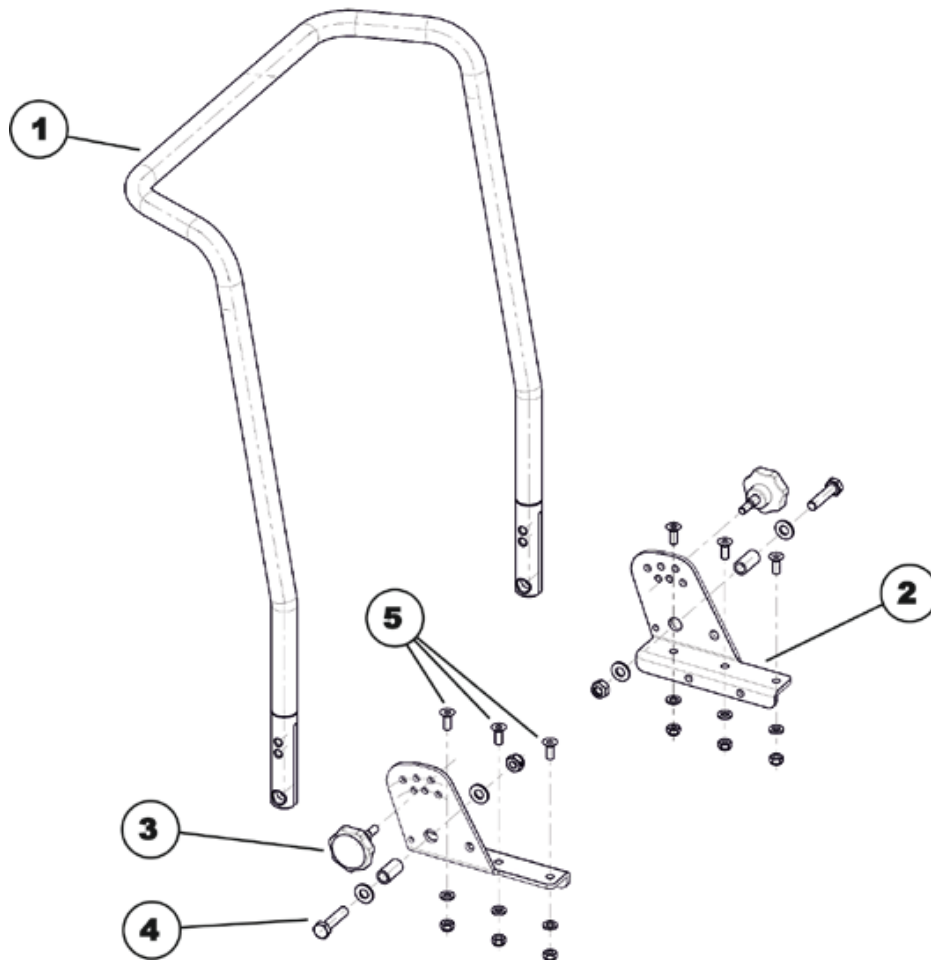
Dismantling the backrest unit:

- Remove the backrest cushion.
- Undo and remove the handwheels (3).
- Use two 13 mm open-ended wrenches to undo the bolts (4) including the nuts and washers on the left-hand and right-hand side of the chair.
- Remove the backrest tube (1) from the backrest holders (2).
- If the backrest holders also need to be replaced: Undo and remove the Allen screws (5) including the nuts and washers on the left-hand and right-hand side of the chair. To do this, use a 5 mm Allen key and a 10 mm open-ended wrench.

Refitting the backrest unit:

- Replace the parts in the reverse order.
- To conclude, you should always carry out a trial run to test the vehicle functions.

8.12 Armrest



WARNING!

After any adjustments, repair or service and before use, make sure that all attaching hardware is tightened securely - otherwise injury or damage may result.

- Before performing any maintenance, adjustment or service verify that On/Off switch on the joystick is in the off position.

8.12.1 Removing/Installing Armrest (Captain's seat)



Requirements:

- 12 mm box wrench
- 13 mm box wrench

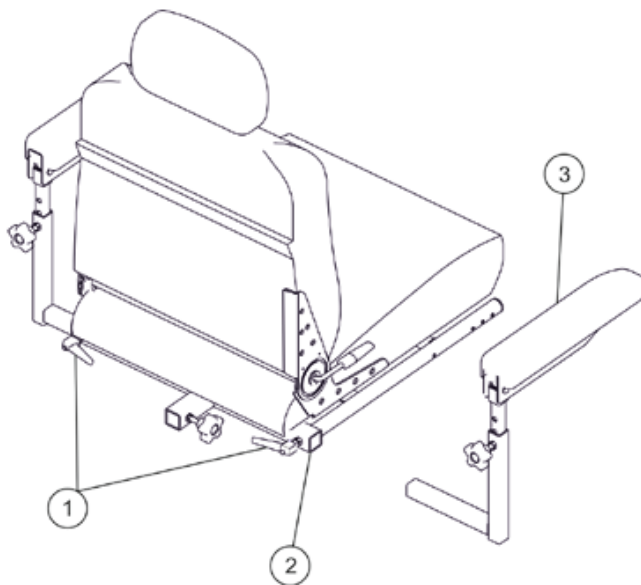

- If necessary, disconnect the joystick. Refer to chapter 8.2.3.
- Loosen the lever (1) that secures the arm (3) to the arm support tube (2).
- Remove the arm (3) from the arm support tube (2).
- If necessary, repeat the first three steps to remove the remaining arm.

8.12.2 Replacing the armrest assembly (Captain's seat)

**Requirements:**

- 12 mm box wrench
- 13 mm box wrench

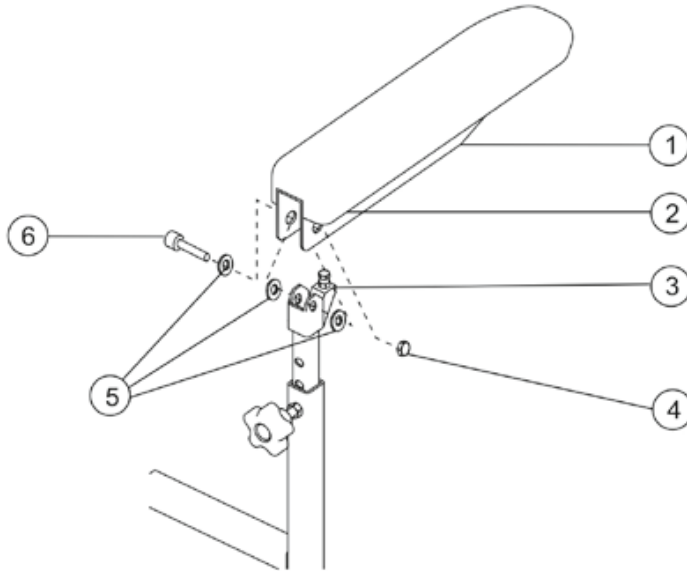

- If necessary, remove the joystick. Refer to chapter 8.2.1.
- Remove the mounting screw (6), three washers (5), and locknut (4) that secures the existing armrest (1) to the arm post.
- Discard the old/existing armrest (1).
- Position the new armrest (1) on the armrest post (3) and secure with the mounting screw (6), three washers (5), and locknut (4).
- If necessary, install the joystick. Refer to chapter 8.2.1.
- Repeat the first four steps for the opposite armrest if necessary.

8.12.3 Removing/Installing Armrest (Modulite seat)

**Requirements:**

- 8 mm Allen key

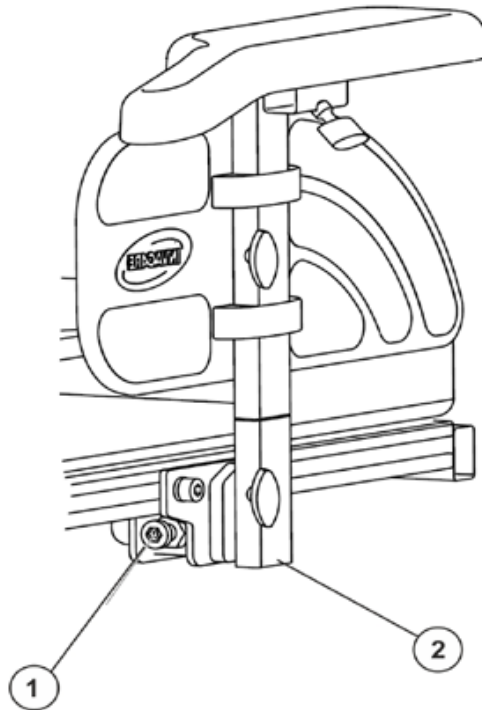

- If necessary, disconnect the joystick. Refer to chapter 8.2.3.
- Loosen the Allen screw (1) with an 8 mm Allen key.
- Pull the armrest (2) out of the holder.
- If necessary, replace the armrest including the holder.
- Refit the parts in reverse order.

8.12.4 Replacing the armrest (Modulite seat)

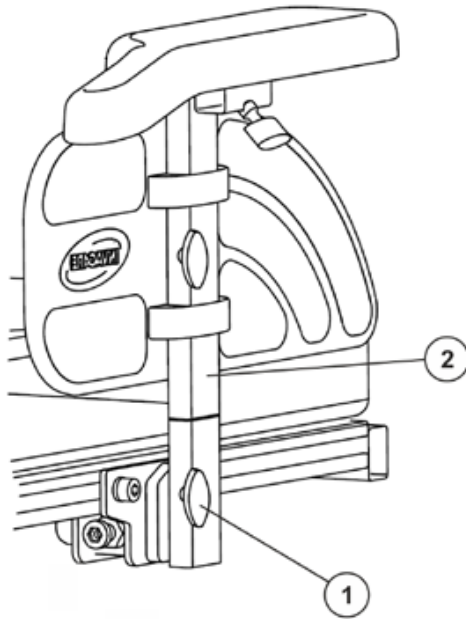

- If necessary, remove the joystick. Refer to chapter 8.2.3.
- Loosen the wing screw (1) that secures the armrest (2) to the holder.
- Replace the armrest (2).
- Refit the parts in reverse order.

8.13 Footboard

8.13.1 Removing/Installing the footboard assembly



WARNING!

Pinch point may occur when rotating the footboard assembly.

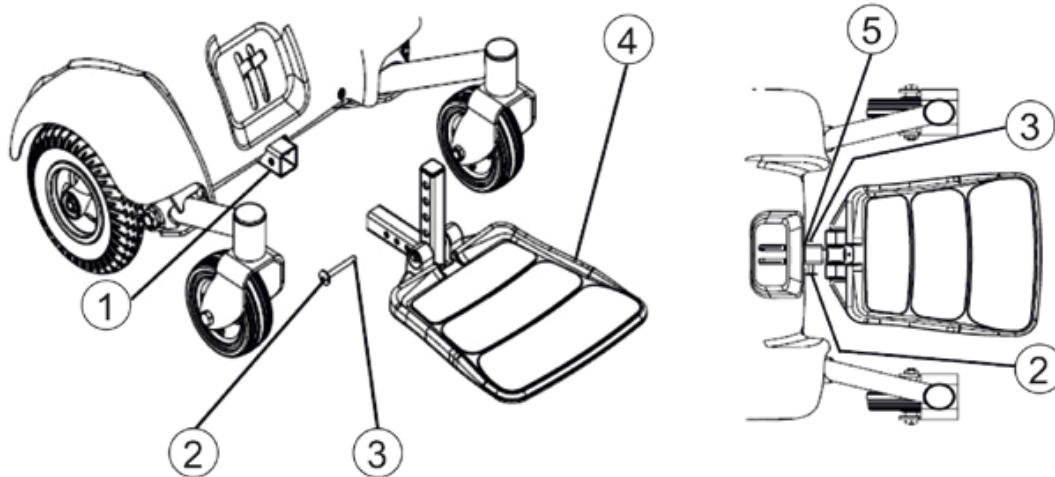

Removing the footboard assembly:

- Remove the quick release pin (2) that secures the footboard assembly (4) to the wheelchair frame by depressing the button while sliding the pin out.
- Remove the footboard assembly (4) from the wheelchair frame.

Installing the footboard assembly:



WARNING!

Make sure the detent balls (3) of the quick-release pin (2) are fully released beyond the outer edge of the tube (5) before operating the wheelchair. Otherwise, injury and/or damage may result. Keep detent balls clean.

- Position the footboard assembly (4) onto the wheelchair frame so that the mounting hole (1) in the wheelchair frame aligns with the desired mounting hole (1) in the footboard assembly (4).
- Install the quick release pin (2) by depressing the button while sliding the pin in. Ensure that the detent balls (3) are engaged with the outer edge of the tube (5).

9 Accessoires



WARNING!

After any adjustments, repair or service and before use, make sure that all attaching hardware is tightened securely - otherwise injury or damage may result.

- Before performing any maintenance, adjustment or service verify that On/Off switch on the joystick is in the off position.

9.1 Replacing the postural belt

9.1.1 Replacing the postural belt (Captain's seat)



WARNING!

Always wear your postural belt (3). The postural belt (3) is a positioning belt only. It is not designed for use as a safety device withstanding high stress loads such as auto or aircraft safety belts. If signs of wear appear, belt must be replaced immediately.



Requirements:

- 3/16" Allen key

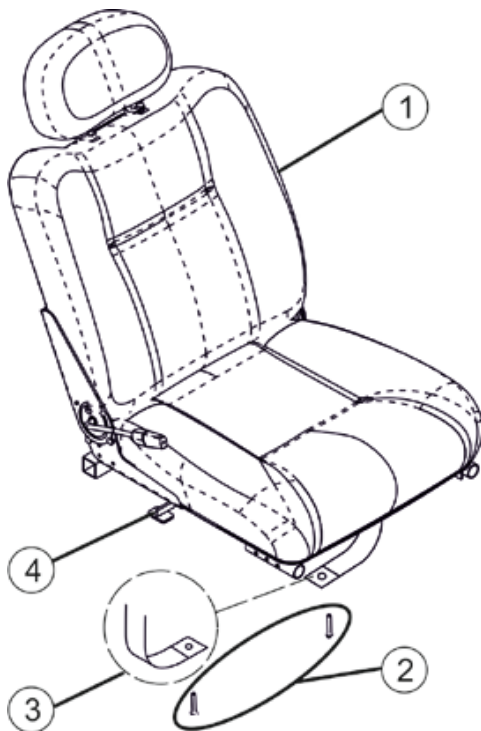

- Remove the two mounting screws (2) that secure the postural belt (3) to the seat frame.
- Remove the two halves of the postural belt (3) from the rear seat frame.
- Reposition the two new postural belt (3) halves underneath seat rails.
- Reinstall the two mounting screws (2) to secure the postural belts (3) to the seat frame. Securely tighten.

9.1.2 Replacing the postural belt (standard seat)

**Note**

A nut is fixed between the two washers (2) and (4) as a spacer so that the belt mounting can rotate freely.

**Requirements:**

- 5 mm Allen key
- 13 mm socket wrench

- Remove the plastic cap (5).
- Loosen the bolt (3) and the associated nut (in the figure this is covered by the plastic cap) with a 5 mm Allen key and a 13 mm socket wrench.
- Remove the nut.
- Remove the bolt including postural belt and flat washers (2) and (4).
- Remove the flat washers (4).
- Replace the postural belt (1).
- Refit the parts in the reverse order.

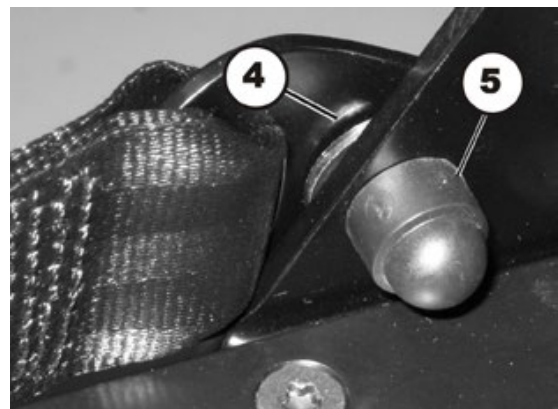
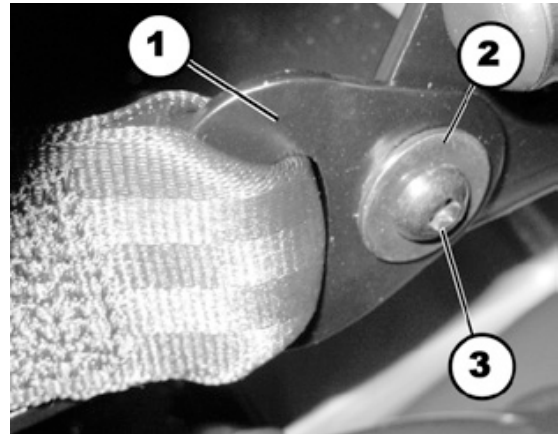

9.1.3 Replacing postural belts (Modulite seat)

9.1.3.1 Installation on the backrest mounting bracket (simple backrest)

**Requirements:**

- 13 mm socket wrench
- 5 mm Allen key

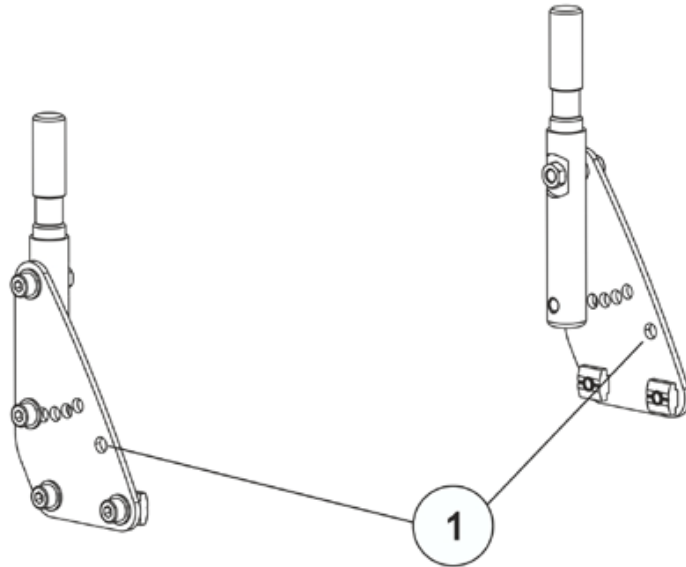

- The postural belts are attached via the drill hole (1) at the top right.
- The installation of postural belts is described in chapter 9.1.

9.1.3.2 Installation on the backrest mounting bracket (adjustable seat)

**Requirements:**

- 5 mm Allen key

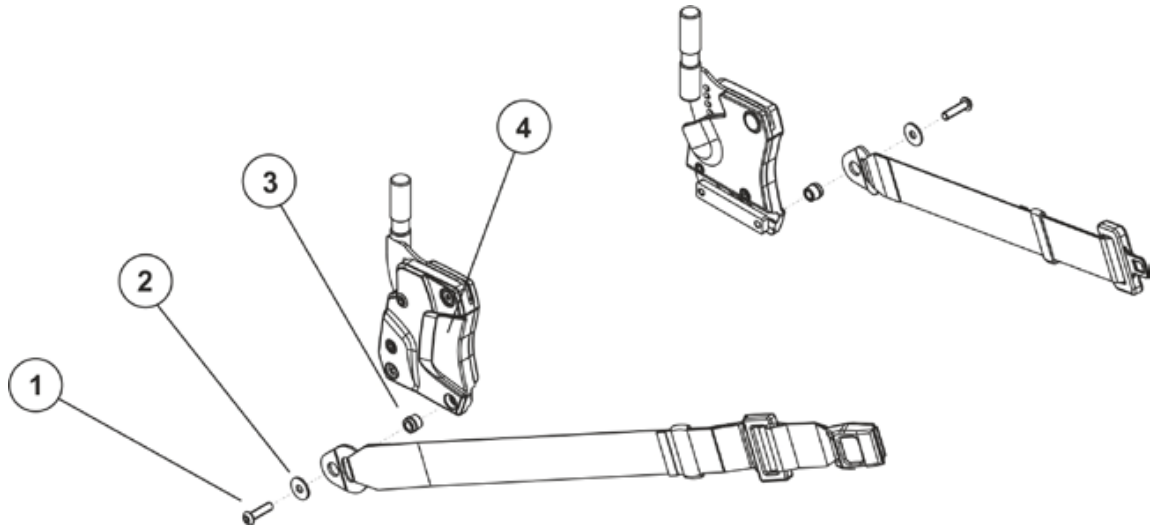

- Loosen the screw (1) with a 5 mm Allen key.
- Remove the screw (1), the corresponding washer (2) and the postural belt and belt winder (3) from the backrest mounting bracket (4).
- Replace the postural belt.
- Refit the parts in the reverse order.

9.1.3.3 Installation on the seat frame profile (adjustable seat)

**Requirements:**

- 5 mm Allen key

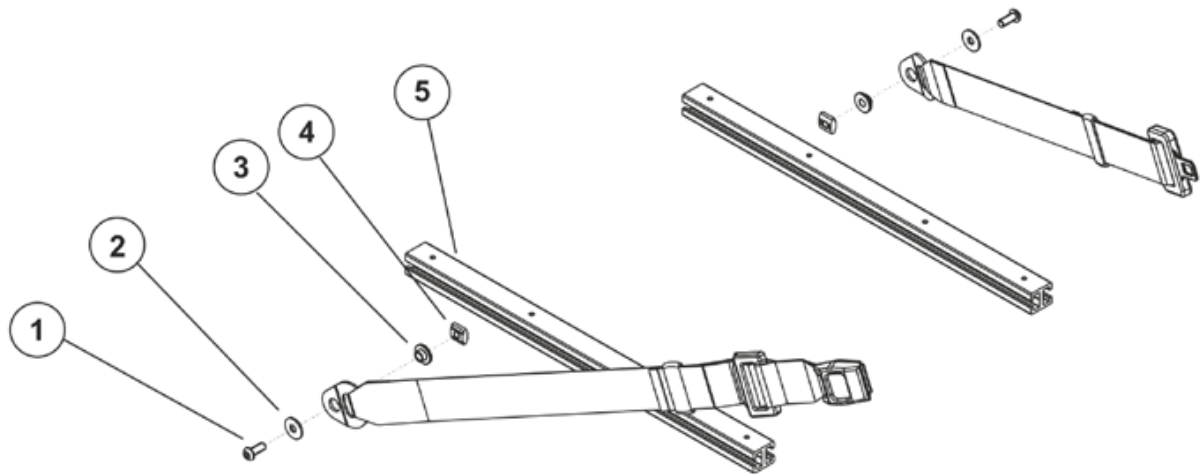

- Loosen the screw (1) with a 5 mm Allen key.
- Remove the screw (1), the washer (2), the postural belt, the sliding bushing (3) and the sliding block (4) from the seat frame profile (5).
- Replace the postural belt.
- Refit the parts in the reverse order.

9.2 Further accessoires



Note

The installation instructions for additional accessories are available at your Invacare® specialist supplier or directly from Invacare®.

10 Adjusting the seating position

In order to adapt the mobility device optimally to the requirements of the user, we recommend that you ask your authorized Invacare® dealer to adjust the seat depth individually.

Adapting the seat to the user's seating position depends on which seat has been fitted, and should be carried out in the following sequence.

1. Adjusting the lower leg length and seat depth, see chapter 10.1.
2. Adjusting the seat height and seat angle, see chapter 10.2.
3. Adjusting the center of gravity of the seat frame, see chapter 10.3.
4. Repetition of steps 3 to 4, if necessary.



WARNING!

Risk of injury by tipping of mobility device caused by blocked casters.

- *Always check the seat depth settings for both forward and reverse movement. Make sure that casters can rotate freely and have not contact to any fixed mobility device component.*
-



IMPORTANT!

Any changes to the drive program can affect the driving characteristics and the tipping stability of the vehicle!

- *Changes to the drive program may only be carried out by trained Invacare® specialist dealers!*
 - *Invacare® supplies all mobility aids with a standard drive program ex-works. Invacare® can only give a warranty for safe vehicle driving behaviour - especially tipping stability - for this standard drive program!*
-



CAUTION: Risk of crushing

The seat is very heavy. Risk of injury to hands and feet.

- *Pay attention to the hand and feet.*
 - *Use proper lifting techniques.*
-

10.1 Adjusting the lower leg length and seat depth

10.1.1 Adjusting the lower leg length

Invacare® offers a range of legrests which can be adjusted individually.

See user manual.

10.1.2 Adjusting the seat depth

Pay attention to the center of gravity of the seat. The seat can be adjusted by mounting the seat frame farther towards the front or the rear on the seat, see also chapter 10.3.

10.1.2.1 Captain's seat



Requirements:

- Phillips screwdriver

- Remove the seat, as described in chapter 8.9.1.1.
- Remove the seat base (3) from the seat assembly, as described in subchapter **Adjusting seat position on seat base**.
- Remove the six mounting screws (5) located under the seat that secure the seat back (1) assembly in place.
- Adjust seat back (1) assembly to desired position and reinstall the six mounting screws (5). Securely tighten.

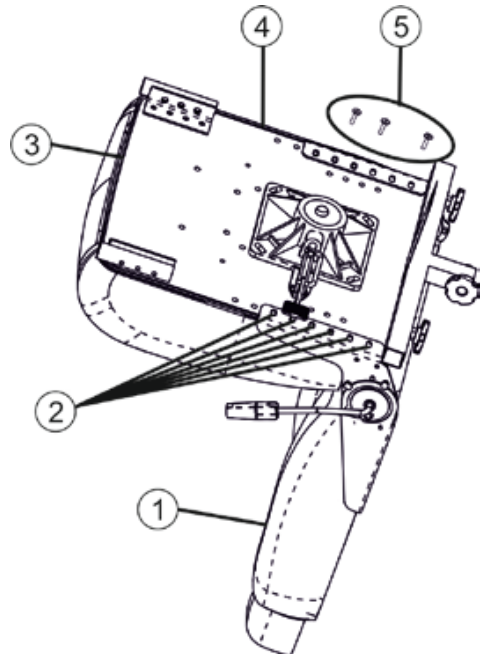

Note

For proper seat depth positions see following figure.

For example, to achieve maximum seat depth, the front mounting hole (2) on the seat back bracket (4) aligns with the third hole on the seat base (3).

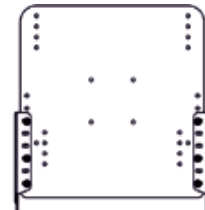
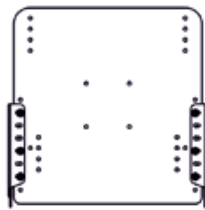
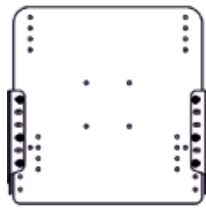

Minimum Seat Depth	
Seat Depth	Seat Size
16 inch (406,4 mm)	18 x 18 inch (457,2 x 457,2 mm)

Middle Seat Depth	
Seat Depth	Seat Size
17 inch (457,2 mm)	18 x 18 inch (457,2 x 457,2 mm)

Maximum Seat Depth	
Seat Depth	Seat Size
18 inch (457,2 mm)	18 x 18 inch (457,2 x 457,2 mm)

- Install the seat base (3) onto the seat assembly. Refer to adjusting the seat position subchapter **Adjusting seat position on seat base**.
- Reinstall the seat, as described in chapter 8.9.1.1.

Adjusting seat position on seat base



WARNING!

Refer to the table in for proper seat post mounting positions (1). For users over 220 lbs (100 kg) - seat must be in the 1-inch (25,4 mm) back position when using seat post mounting holes 3, 4 and 5. Refer to adjusting the seat height in chapter 10.2.1.

- Remove the seat, as described in chapter 8.9.1.1.
- Remove the four mounting screws (4) and washers (3) securing the seat pivot to the seat base (2).
- Separate the seat pivot from the seat base.
- Refer to following figure to determine the correct mounting holes to achieve the desired seat position.

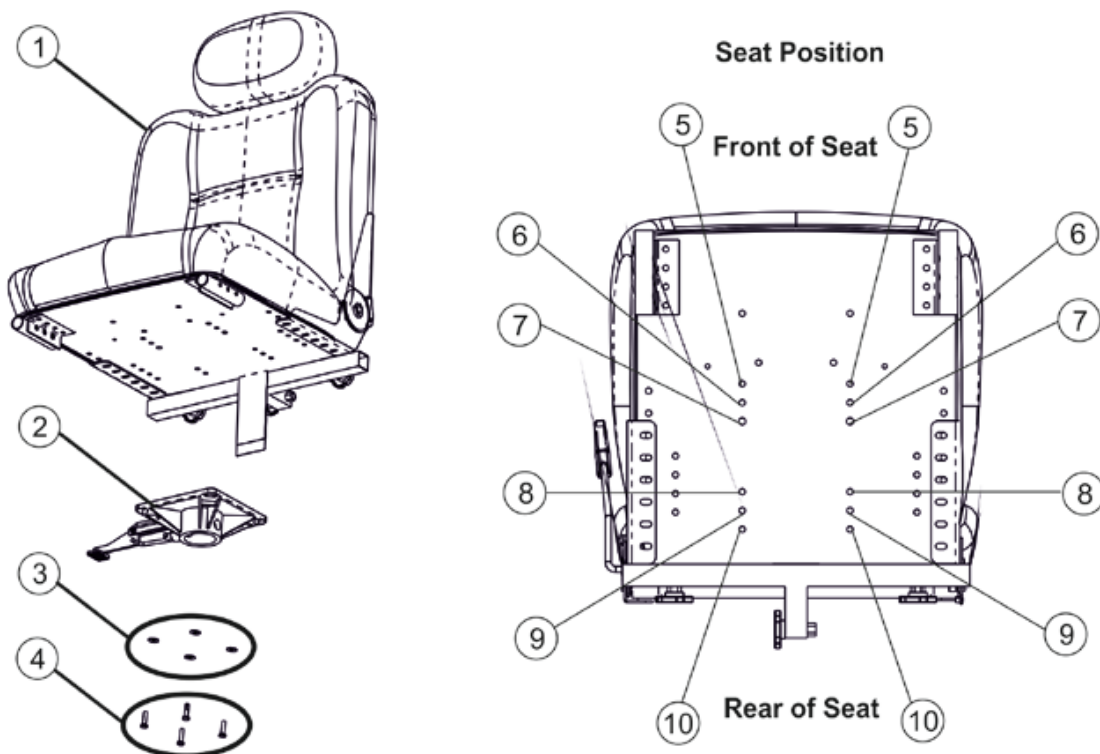

1	Seat assembly	6	Standard seat position
2	Seat base	7	1-inch (25,4 mm) forward seat position*
3	Washers	8	1-inch (25,4 mm) back seat position
4	Mounting screws	9	Standard seat position
5	1-inch (25,4 mm) back seat position	10	1-inch (25,4 mm) forward position*

- Align the mounting holes on the seat pivot (see the table on page 101) with the mounting holes on the seat base.
- Using the four mounting screws and washers, secure the seat base to the seat assembly. Securely tighten.
- Reinstall the seat, as described in chapter 8.9.1.1.



Note

* For users over 220 lbs (100 kg) - do not use 1-inch (25,4 mm) forward position.

Proper seat positions for 18-inch (457,2 mm) deep back setting

Weight Limitation	Seat post Mounting hole	1-Inch (25,4 mm) Back	Standard	1-Inch (25,4 mm) Forward
300 LBS (136 kg)	1	Y	Y	N/A
	2	Y	Y	N/A
	3	Y	N/A	N/A
	4	Y	N/A	N/A
	5	Y	N/A	N/A
220 LBS (100 kg)	1	Y	Y	Y
	2	Y	Y	N/A
	3	Y	N/A	N/A
	4	Y	N/A	N/A
	5	Y	N/A	N/A

Weight Limitation	Seat post Mounting hole	1-Inch (25,4 mm) Back	Standard	1-Inch (25,4 mm) Forward
150 LBS (68 kg)	1	Y	Y	Y
	2	Y	Y	Y
	3	Y	Y	Y
	4	Y	Y	Y
	5	Y	Y	Y
Legend: Y - Use N/A - Do not use				

10.1.2.2 Standard seat



WARNING: Risk of crushing!

The seat is very heavy. Risk of injury to hands and feet!

- Use proper lifting techniques.



Requirements:

- 4 mm Allen key
- 10 mm open-ended wrench

The pictures show the standard seat without seat cushion from above (A) und below (B).

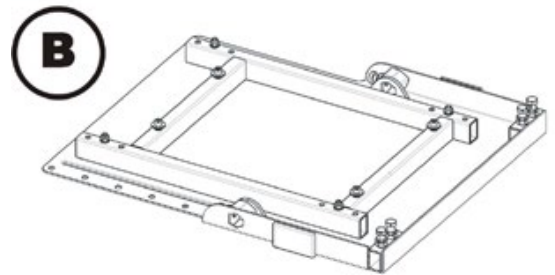
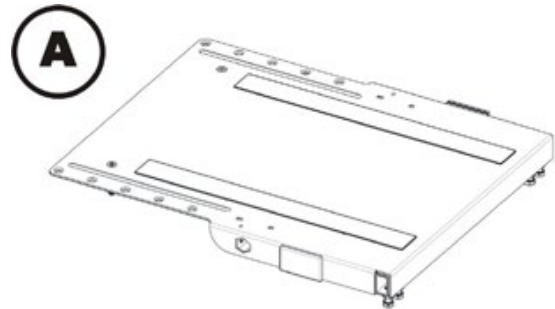

- Rear bolts (1)
- Front bolts (2)
- Seat plate (3)
- Seat frame (4)
- The seat plate can be fixed in three different positions on the seat frame.
- Front fixing (V)
- Centre fixing (M)
- Rear fixing (H)

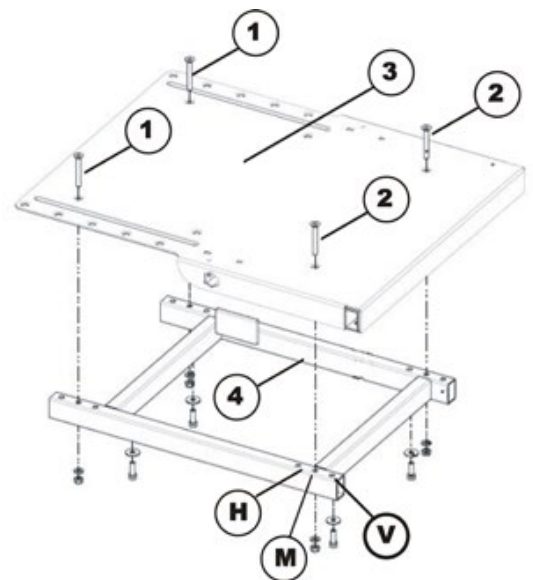

The picture shows where the drillholes for fixing the seat frame (3) are located on the base frame.

- Rear drillholes (1)
- Front bolts (2)
- The seat frame can only be fixed in one position on the base frame.

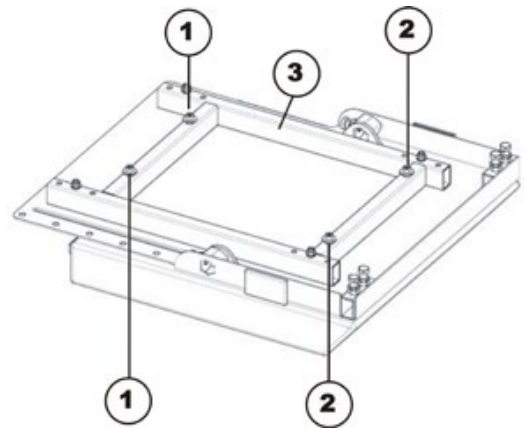

10.1.2.3 Modulite seat



Requirements:

- 6 mm Allen key

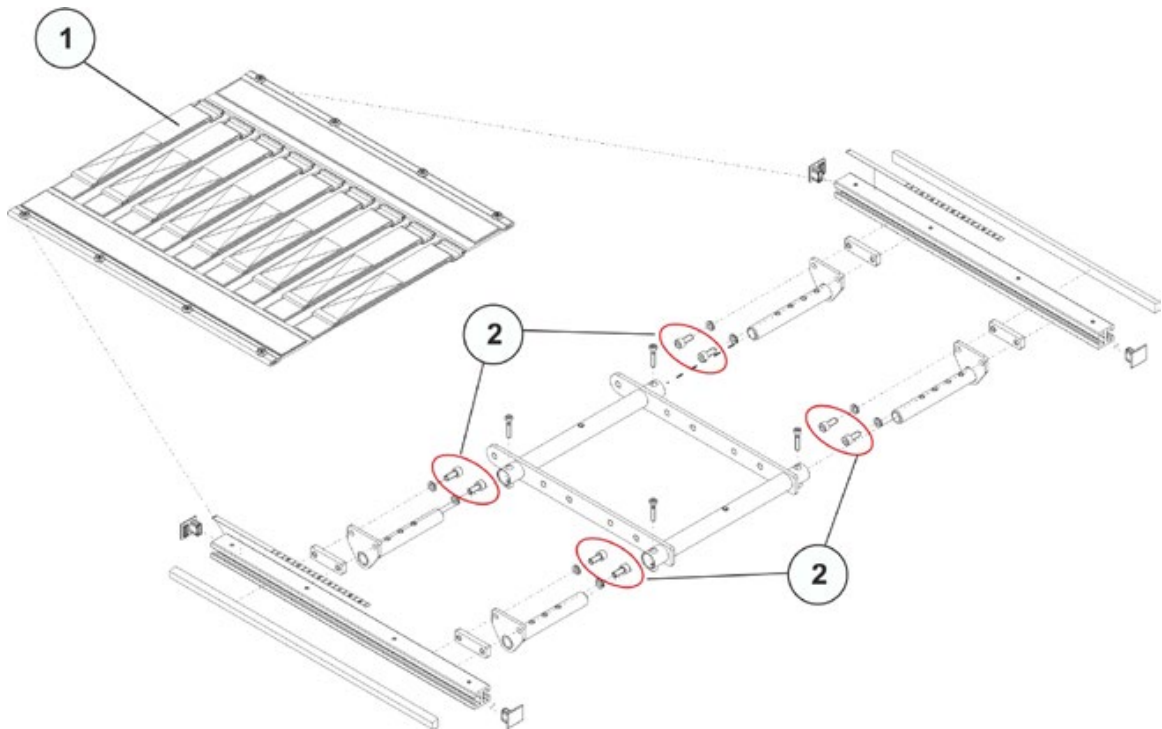

- Remove the seat plate or sling seat (1), see chapter 8.10.1.
- Loosen the socket head screws (2) in the front and rear, left and right – DO NOT remove.
- Shift the position of the seat.
- Re-tighten the screws.
- Install the seat plate or the sling seat again.

10.2 Adjusting the seat height and seat angle

10.2.1 Adjusting the seat height (Captain's seat and standard seat)



Note

The seat can be adjusted to five height positions in 1-inch (25,4 mm) increments.



WARNING!

The proper seat post mounting positions (1) are described in chapter 10.1.2.1. For users over 220 lbs (100 kg) - mounting holes 3, 4 and 5 must be used with the seat in the 1-inch (25,4 mm) back position. Refer to adjusting seat position on seat base in chapter 10.1.2.1



Requirements:

- 3/8" Allen key

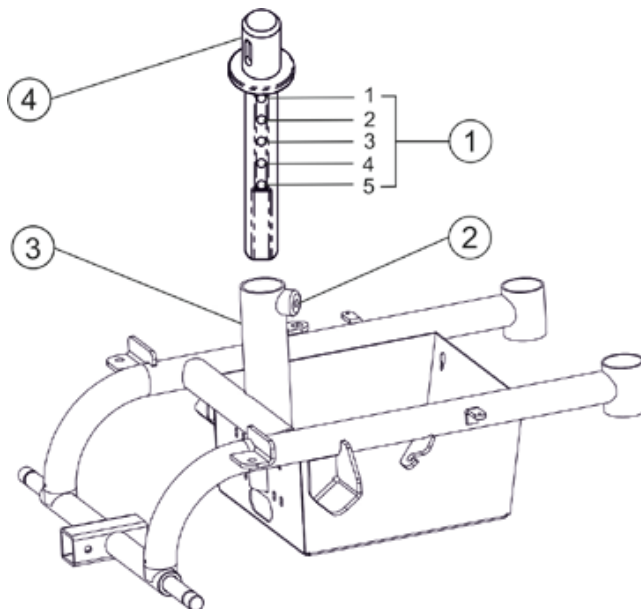

- Remove the seat, as described in chapter 8.9.1.1.
- Remove the mounting screw (2) that secures the seat post (4) to the support tube (3).
- Adjust the seat post (4) to desired mounting position.
- Reinstall mounting screw (2). Securely tighten.
- Reinstall the seat, as described in chapter 8.9.1.1.

10.2.2 Adjusting the seat height (Modulite seat)

**Requirements:**

- 13 mm open-ended wrench

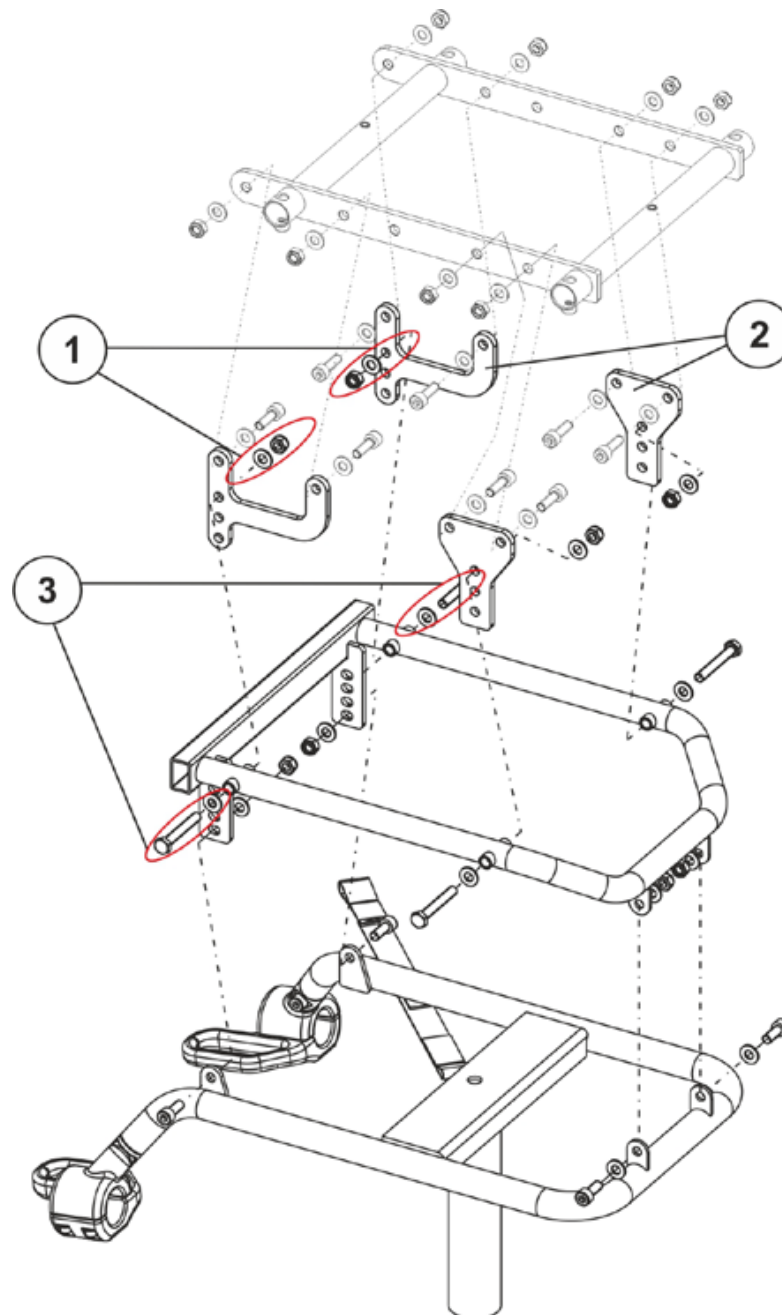

- Remove the seat plate or sling seat, see chapter 8.10.1.
- Loosen and remove the screws (3) and the self-locking nuts (1) in the front and rear (2) with a 13 mm open-ended wrench.

Seat height		
Mounting position	Seat plate	Sling seat
a	450 mm	480
b	470 mm	500
c	490 mm	520

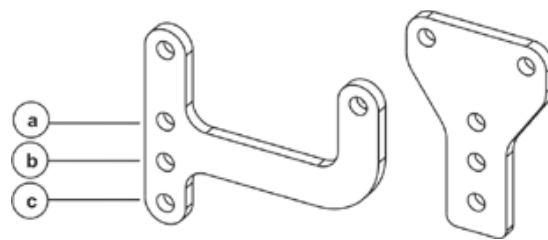

- Adjust the seat frame (2) to the desired mounting position (a, b or c).
- Refit the screws and self-locking nuts.
- Install the seat plate or the sling seat again.

10.2.3 Adjusting the seat angle (Modulite seat)



Requirements:

- 6 mm Allen key
- 13 mm open-ended wrench

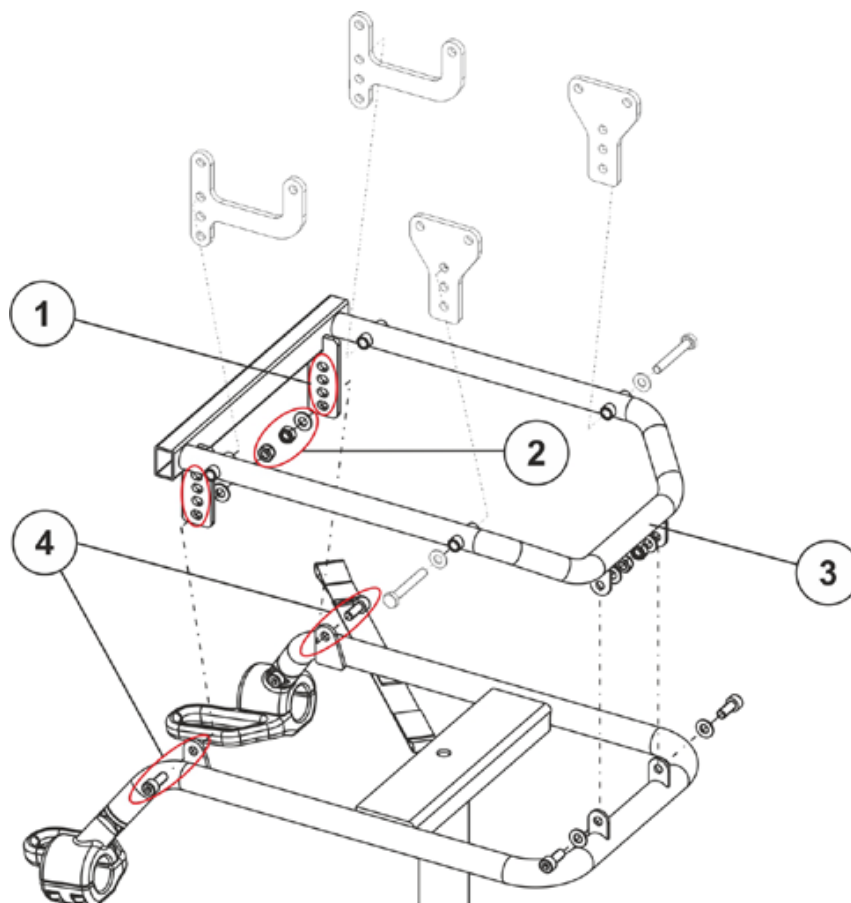

- Remove the seat plate or sling seat, see chapter 8.10.1.
- Loosen and remove the screws (4) and the self-locking nuts (2) including the washers (2) with a 13 mm open-ended wrench and a 6 mm Allen key.

Mounting position	Seat angle
a	0°
b	2°
c	4°
d	6°

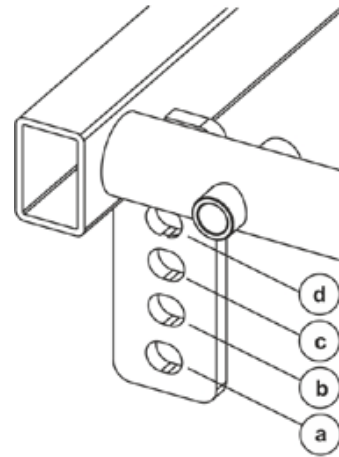

- Choose the desired hole (1) to adjust the seat angle with the seat frame (3). (pay attention to the desired mounting position a ... d).
- Refit the screws (4) and self-locking nuts (2) including the washers.
- Adjust the seat height if necessary, as described in chapter 10.2.2.
- Install the seat plate or the sling seat again.

10.3 Adjusting the center of gravity of the seat

The center of gravity of the seat can be adjusted by mounting the seat frame farther towards the front or the rear on the seat.



IMPORTANT

The seating system of the power wheelchair is delivered ex works with an optimally adjusted center of gravity. Any change in this adjustment setting can negatively influence the stability of the power wheelchair.

- You must perform an individual risk analysis every time you change the center of gravity of the seating position, in order to ensure the safety and stability of the power wheelchair.



(A)

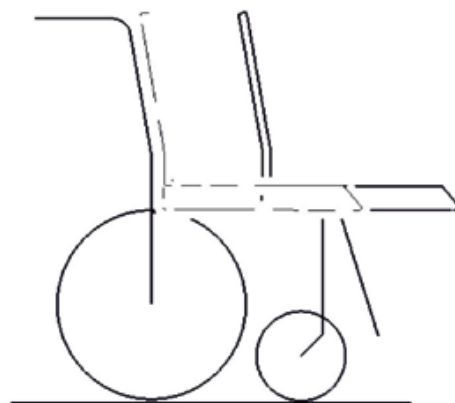

(B)

A: Seat depth

B: Center of gravity of the seat/ seat position

**Note**

The user weight and seat depth have strong influences on the choice of the center of gravity of the seat. If the user is heavy and the seat depth is greater, the focus should be the farther back.

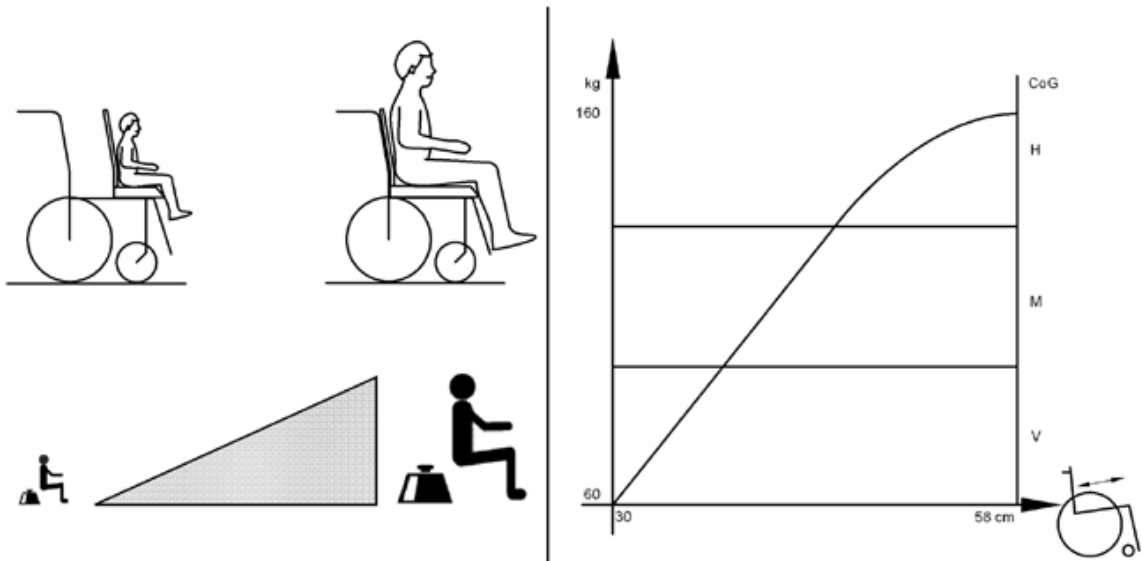

For best possible driving characteristics of rear-wheel drive wheelchairs, the weight to be distributed: 30 – 40 % front and 60 - 70 % rear.

**WARNING!****Risk of damage due to collisions of the legrests with other parts of the wheelchair!**

- Set the legrests to the smallest angle before adjusting the seat center of gravity.
- Pay attention with adjusting the seat center of gravity that the legrests do not touch any other parts of the wheelchair. This ensures that the legrests can not collide with other parts of the wheelchair.

10.3.1 Captain's seat and standard seat

Depending on the seat that is installed, you can attach the seat at different points on the seat frame and thus set the seat depth, see chapter 10.1.2.1 (Captain's seat) and chapter 10.1.2.2 (standard seat).

10.3.2 Modulite seat

See chapter 10.1.2.3 and 10.2.3.

11 Final check

After servicing, always carry out a trial run to test the vehicle functions to ensure correct and safe functioning of the mobility device.

Service addresses

A	Invacare Austria GmbH	☎:	+43 6232 5 53 50
	Herzog Odilostrasse 101	Fax:	+43 6232 5 53 54
	A-5310 Mondsee	@:	info@invacare-austria.com
	Austria	WWW:	www.invacare.at

B	Invacare n.v.	☎:	+32 (0)50 83 10 10
	Autobaan 22	Fax:	+32 (0)50 83 10 11
L	B-8210 Loppem (Brugge)	@:	belgium@invacare.com
	Belgium	WWW:	www.invacare.be

CH	Invacare AG	☎:	+41 (0)61487 70 80
	Benkenstraße 260	Fax:	+41 (0)61487 70 81
	CH-4108 Witterswil	@:	switzerland@invacare.com
	Switzerland	WWW:	www.invacare.ch

D	Invacare Aquatec GmbH	☎	+49 (0)7562 70 00
	Alemannenstraße 10	Fax	+49 (0)7562 7 00 66
	88316 Isny	@:	info@invacare-aquatec.com
	Deutschland	WWW:	www.invacare-aquatec.de

DK	Invacare A/S	☎ (Kundeservice):	+45 (0)36 90 00 00
	Sdr. Ringvej 37	Fax (Kundeservice):	+45 (0)36 90 00 01
	DK-2605 Brøndby	@:	denmark@invacare.com
	Danmark	WWW:	www.invacare.dk

E	Invacare® SA	☎:	+34 (0)972 49 32 00
	c/ Areny s/n	Fax:	+34 (0)972 49 32 20
	Polígon Industrial de Celrà	@:	contactsp@invacare.com
	E-17460 Celrà (Girona)	WWW:	www.invacare.es
ESPAÑA			

F	Invacare® Poirier SAS	☎:	+33 (0)247 62 64 66
	Route de St Roch	Fax:	+33 (0)247 42 12 24
	F-37230 Fondettes	@:	contactfr@invacare.com
	France	WWW:	www.invacare.fr

GB	Invacare® Ltd	☎ (Customer services):	+44 (0)1656 77 62 22
	Pencoed Technology Park	Fax (Customer services):	+44 (0)1656 77 62 20
	Pencoed	@:	uk@invacare.com
	Bridgend CF35 5HZ	WWW:	www.invacare.co.uk
United Kingdom			

I	Invacare Mecc San s.r.l.	☎:	+39 0445 38 00 59
	Via dei Pini, 62	Fax:	+39 0445 38 00 34
	I - 36016 Thiene (VI)	@:	italia@invacare.com
	Italia	WWW:	www.invacare.it

IE	Invacare Ireland Ltd.	☎:	+353 18 10 70 84
	Unit 5 Seatown Business Campus	Fax:	+353 18 10 70 85
	Seatown Rd, Swords	@:	ireland@invacare.com
	County Dublin	WWW:	www.invacare.ie
Ireland			

N	Invacare® AS Grensesvingen 9 Postboks 6230 Etterstad N-0603 Oslo Norge	☎ (Kundeservice): +47 (0)22 57 95 00 Fax (Kundeservice): +47 (0)22 57 95 01 @: norway@invacare.com @: island@invacare.com WWW: www.invacare.no
NL	Invacare® B.V. Celsiusstraat 46 NL-6716 BZ Ede Nederland	☎: +31 (0)318 69 57 57 Fax: +31 (0)318 69 57 58 @: nederland@invacare.com @: csede@invacare.com WWW: www.invacare.nl
P	Invacare Lda Rua Estrada Velha, 949 P-4465-784 Leça do Balio Portugal	☎: +351 225 10 59 46 ☎: +351 225 10 59 47 Fax: +351 225 10 57 39 @: portugal@invacare.com WWW: www.invacare.pt
S	Återförsäljare: Invacare® AB Fagerstagatan 9 S-163 91 Spånga Sverige	☎ (Kundtjänst): +46 (0)8 761 70 90 Fax (Kundtjänst): +46 (0)8 761 81 08 @: sweden@invacare.com @: finland@invacare.com WWW: www.invacare.se
FIN	Tillverkare: Invacare® Deutschland GmbH Kleiststraße 49 D-32457 Porta Westfalica Deutschland	MÖLNDAL ☎: +46 (0)31 86 36 00 Fax: +46 (0)31 86 36 06 @: ginvacare@invacare.com LANDSKRONA ☎: +46 (0)418 2 85 40 Fax: +46 (0)418 1 80 89 @: linvacare@invacare.com OSKARSHAMN ☎: +46 (0)491 1 01 40 Fax: +46 (0)491 1 01 80 @: oinvacare@invacare.com
Eastern european countries	European Distributor Organisation (EDO) Kleiststraße 49 D-32457 Porta Westfalica Deutschland	☎ +49 (0)5731 75 45 40 Fax +49 (0)5731 75 45 41 @: edo@invacare.com WWW: www.invacare.de