

2002 ENGINES

3.5L V6 - Sedona

GENERAL

SPECIFICATIONS

Description	Specification	Limit
	3.5	
General		
Type	DOHC V-type	
Number of cylinders	6	
Bore	93 mm (3.66 in)	
Stroke	85.8 mm (3.38 in)	
Total displacement	3497 cc (213.3 cu.in)	
Compression ratio	10.0	
Firing order	1-2-3-4-5-6	
Idle R.P.M	700±100	
Ignition timing at idling speed	BTDC 10°±2°	
Valve timing		
Intake valve		
Opens (BTDC)	11.5°	
Closes (ABDC)	60.5°	
Exhaust valve		
Opens (BBDC)	43.5°	
Closes (ATDC)	20.5°	
Camshaft		
Cam height (mm)		
Intake	35.098 ~ 35.298 (1.38 - 1.39 in)	
Exhaust	34.81 ~ 35.01 (1.37 - 1.38 in)	
Journal O.D. (mm)	25.951 ~ 25.970 (1.02 - 1.022 in)	
Bearing oil clearance (mm)		
	0.05 ~ 0.09 (0.002 - 0.0035 in)	
End play (mm)		
	0.1 ~ 0.2 (0.0039 - 0.0079 in)	
Cylinder head		
Flatness of gasket surface (mm)	0.03 (0.0012 in)	
Flatness of manifold mounting surface (mm)		
Intake	Max 0.5 (0.0197 in)	
Exhaust	Max 0.15 (0.0059 in)	

Fig. 1: General Specifications
 Courtesy of KIA MOTORS AMERICA, INC.

Description	Specification	Limit
	3.5	
Diameter of valve guide hole (mm)		
0.05 OS	12.05 - 12.068 (0.474 - 0.475 in)	
0.25 OS	12.25 - 12.268 (0.482 - 0.483 in)	
0.50 OS	12.50 - 12.518 (0.492 - 0.493 in)	
Diameter of seat ring hole of intake valve (mm)		
0.3 OS	36.30 - 36.325 (1.429 - 1.430 in)	
0.6 OS	36.60 - 36.625 (1.441 - 1.442 in)	
Diameter of seat ring hole of exhaust valve (mm)		
0.3 OS	33.30 - 33.325 (1.311 - 1.312 in)	
0.6 OS	33.60 - 33.625 (1.323 - 1.324 in)	
Valve		
Valve length (mm)		
Intake	106.28 (4.18 in)	
Exhaust	105.4 (4.15 in)	
Outer diameter of stem		
Intake	6.565 - 6.580 (0.258 - 0.259 in)	
Exhaust	6.530 - 6.550 (0.0257 - 0.258 in)	
Face angle	45°- 45.5°	
Seat width (Margin)		
Intake (mm)	1.0 (0.039 in)	0.5 (0.02 in)
Exhaust (mm)	1.5 (0.059 in)	1.0 (0.039 in)
Clearance (Between stem and guide)		
Intake (mm)	0.02 - 0.05 (0.0009 - 0.0020 in)	0.1 (0.0039 in)
Exhaust (mm)	0.05 - 0.085 (0.002 - 0.0033 in)	0.15 (0.0059 in)
Valve spring		
Free length	46.4 (1.8268 in)	
Load (kg/mm)		
K1	2.816	K1: Spring constant when installing the valve K2: Spring constant when lifting the valve
K2	3.535	
Rectangularity	2°	
Piston (mm)		
Outer diameter	92.96 - 92.99 (3.66 - 3.661 in)	
Clearance (Between piston and cylinder)	0.03 - 0.05 (0.0012 - 0.0020 in)	

G00368054

Fig. 2: General Specifications

Description	Specification	Limit
	3.5	
Width of ring groove (mm)		
No. 1	1.503 - 1.505 (0.0592 - 0.0593 in)	
No. 2	1.501 - 1.503 (0.0591 - 0.0592 in)	
Oil	3.010 - 3.030 (0.1185 - 0.1193 in)	
Rings for Service	0.25, 0.50, 0.75, 1.00, oversize	
Piston Ring		
Number of rings per piston	3	
Compression ring	2	
Oil ring	1	
Compression ring type		
No. 1	Barral & innerbevel type	
No. 2	Taper & undercut type	
Oil ring type	3-piece type	
Ring end gap		
No. 1	0.20 - 0.30 mm (0.0079 - 0.0118 in)	0.8 mm (0.031 in)
No. 2	0.45 - 0.60 mm (0.0177 - 0.0236 in)	0.8 mm (0.031 in)
Oil ring side rail	0.2 - 0.7 mm (0.0079 - 0.0276 in)	1 mm (0.039 in)
Ring side clearance		
No. 1	0.04 - 0.08 mm (0.0016 - 0.0315 in)	0.1mm (0.0039 in)
No. 2	0.02 - 0.06 mm (0.0008 - 0.0024 in)	0.1mm (0.0039 in)
Rings for Service	0.25, 0.50, 0.75, 1.00, oversize	
Connecting rod		
Side clearance	0.1 - 0.25 mm (0.00394 - 0.00984 in)	0.4 mm (0.016 in)
Bend	0.05 or less/100 mm (0.002 in or less / 3.937 in)	
Bearing oil clearance	0.022 - 0.040 mm (0.0009 - 0.0016 in)	0.1mm (0.0039 in)
Crankshaft		
Journal O.D.	63.982 - 64.00 mm (2.5190 - 2.5197 in)	
Pin O.D.	54.982 - 55.000 mm (2.1650 - 2.1654 in)	
Out-of-roundness of journal and pin	0.003 mm (0.00018 in)	
end play	0.05 - 0.25 mm (0.002 - 0.01 in)	0.35 mm (0.014 in)
Main bearing oil clearance	0.018 ~ 0.036 mm (0.0071 - 0.0014 in)	

G00368055

Fig. 3: General Specifications
 Courtesy of KIA MOTORS AMERICA, INC.

Description	Specification	Limit
	3.5	
Cylinder block		
Cylinder bore	93.0 mm (3.6614 in)	
Flatness of gasket surface	0.05 mm (0.002 in)	0.2 mm (0.0079 in)
Out-of-roundness	ø0.02 mm (0.00079 in)	
Oil pump		
Side clearance		
Body clearance	0.1 - 0.181 mm (0.0039 - 0.0071 in)	
Side clearance	0.04 - 0.095 mm (0.0016 - 0.0037 in)	
Relief Spring		
Free length	46.3 mm (1.823 in)	
Load	3.43kg / 39.1 mm (1.56 lb/1.54 in)	
Oil filter type	Cartridge Full flow	
Engine oil pressure	640kPa (Conditions: Oil temp is 194~230°F, 90~110°C)	
Engine oil quantity	4.3 l (4.51 US.qts, 3.78 Imp.qts)	
Cooling method	Engine coolant cooling, forced circulation with electric fan	
Cooling system quantity	8.2 l (8.61 US.qts, 7.2 Imp.qts)	
Thermostat		
Type	Wax pellet type with jiggle valve	
Normal opening temperature (°C)	82 (179.6 °F)	
Opening temperature range (°C)	80 - 84 (176 - 183.2 °F)	
Wide open temperature (°C)	95 (203 °F)	
Radiator		
Main valve opening pressure	93.2 - 122.6 kPa (0.95 - 1.25kg/cm ² , 13.5 - 17.8 psi)	
Vaccum valve opening pressure	-0.98 - 4.90 kPa (-0.01 - 0.05kg/cm ² , -0.14 - 0.71 psi)	
Air cleaner		
Type	Dry type	
Element	Unwoven cloth type	
Exhaust pipe		
Muffler	Expansion resonance type	
Suspension system	Rubber hanger	

G00068056

Fig. 4: General Specifications
 Courtesy of KIA MOTORS AMERICA, INC.

TORQUE SPECIFICATIONS

TORQUE SPECIFICATIONS

Application	Ft. Lbs. (N.m)
Air Intake Surge Tank-To-Intake Manifold Bolt\Nut	11-15 (15-20)
Auto Tensioner Fixing Bolt	15-20 (20-27)
Camshaft Bearing Cap Bolt ⁽¹⁾	
Inner Bolt	(2)
Outer Bolt	14-15 (19-21)
Camshaft Sprocket Bolt	58-72 (79-98)
Catalytic Converter Nut	22-30 (30-40)
Center Exhaust Pipe Nut	22-30 (30-40)
Connecting Rod Nut	
Step 1	26 (35)
Step 2	Plus Torque Angle 92 Degrees
Crankshaft Main Bearing Cap Bolt ⁽¹⁾	51-58 (69-79)
Crankshaft Pulley Bolt	133-140 (180-190)
Cylinder Head Bolts ⁽³⁾	77-85 (105-115)
Drive Belt Pulley Bolt	26-41 (35-55)
Drive Belt Tensioner Nut	33-37 (45-50)
Drive Plate & Adapter Plate Bolt	54-57 (73-77)
Engine Cooling Inlet Fitting Attaching Bolt	13-15 (17-20)
Engine Coolant Pump Bolt	
M8	11-16 (15-22)
M10	24-37 (33-50)
Engine Coolant Temperature Sensor & Gauge Unit Bolt	15-30 (20-40)
Engine Hanger Bracket Bolt	20-26 (27-35)
Exhaust Manifold Nut	20-24 (27-32)
Front Exhaust Pipe-To-Converter Bolt	30-44 (40-60)
Front Exhaust Pipe-To-Manifold Nut	22-30 (30-40)
Generator Mount Bolt (Bracket Side)	15-22 (20-30)
Generator Mount Bracket-To-Engine Bolt	15-22 (20-30)
Generator Mount Nut (Engine Front Case Side)	15-22 (20-30)
Intake Manifold Surge Tank Stay Bolt	11-15 (15-20)
Intake Manifold-To-Cylinder Head Bolt ⁽⁴⁾	15-17 (20-23)
Oil Pan Drain Plug	26-33 (35-45)
Oil Relief Valve Plug	30-37 (40-50)
Oil Screen Bolt	11-16 (15-22)
Oxygen Sensor	30-37 (40-50)
Power Steering Oil Pump Bracket-To-Cylinder Head Bolt	13-19 (17-26)
Power Steering Oil Pump-To-Bracket Bolt	13-19 (17-26)
Starter-To-Engine Bolt	20-25 (27-34)

Starter-To-Engine Nut	15-22 (20-30)
Timing Belt Cover Bolt	
M6 Bolt	(2)
M8 Bolt	15-20 (20-27)
Timing Belt Idler Pulley Bolt	37-44 (50-60)
Timing Belt Tensioner Arm Fixing Bolt	26-41 (35-55)
Timing Belt Tensioner Pulley Bolt	32-41 (43-55)
Upper Oil Pan Bolt (10x38 mm) ⁽⁵⁾	22-31 (30-42)
Water Outlet Fitting Bolt	13-15 (17-20)
	INCH Lbs. (N.m)
Air Cleaner Mounting Bolt	71-106 (8-12)
Crank Position Sensor Wheel Screw	44-53 (5-6)
Cylinder Head Cover Bolt ⁽⁶⁾	71-89 (8-10)
Delivery Pipe Installation Bolt	89-133 (10-15)
Fuel Hose Clamp	106-133 (12-15)
Generator Inlet Pipe-To-Front Cylinder Head Assembly Bolt	106-133 (12-15)
Heat Shield-To-Exhaust Manifold Bolt	106-133 (12-15)
Lower Oil Pan Bolt ⁽⁷⁾	89-106 (10-12)
Main Muffler Hanger Support Bracket Bolt	89-133 (10-15)
Oil Filter	106-142 (12-16)
Oil Level Gauge Guide-To-Engine Bolt	106-133 (12-15)
Oil Pressure Switch	71-106 (8-12)
Oil Pump Case Bolts	106-133 (12-15)
Oil Pump Cover Screw	71-133 (8-15)
Oil Seal Case Bolt	89-106 (10-12)
Upper Oil Pan Bolt	
171.5 mm	44-62 (5-7)
152.5 mm	44-62 (5-7)
Rear Plate Bolt	89-106 (10-12)
Throttle Body-To-Surge Tank Bolt	89-115 (10-13)
Transaxle Mounting Plate Bolt	89-106 (10-12)

(1) Tighten bolts evenly in 3-4 steps to specification.

(2) Tighten bolt to 89-106 INCH lbs. (10-12 N.m)

(3) Tighten in sequence to specification. See **Fig. 5** .

(4) Tighten in sequence to specification. See **Fig. 6** .

(5) Tighten in sequence to specification. See **Fig. 7** .

(6) Tighten in sequence to specification. See **Fig. 8** .

Tighten in sequence to specification. See **Fig. 9** .

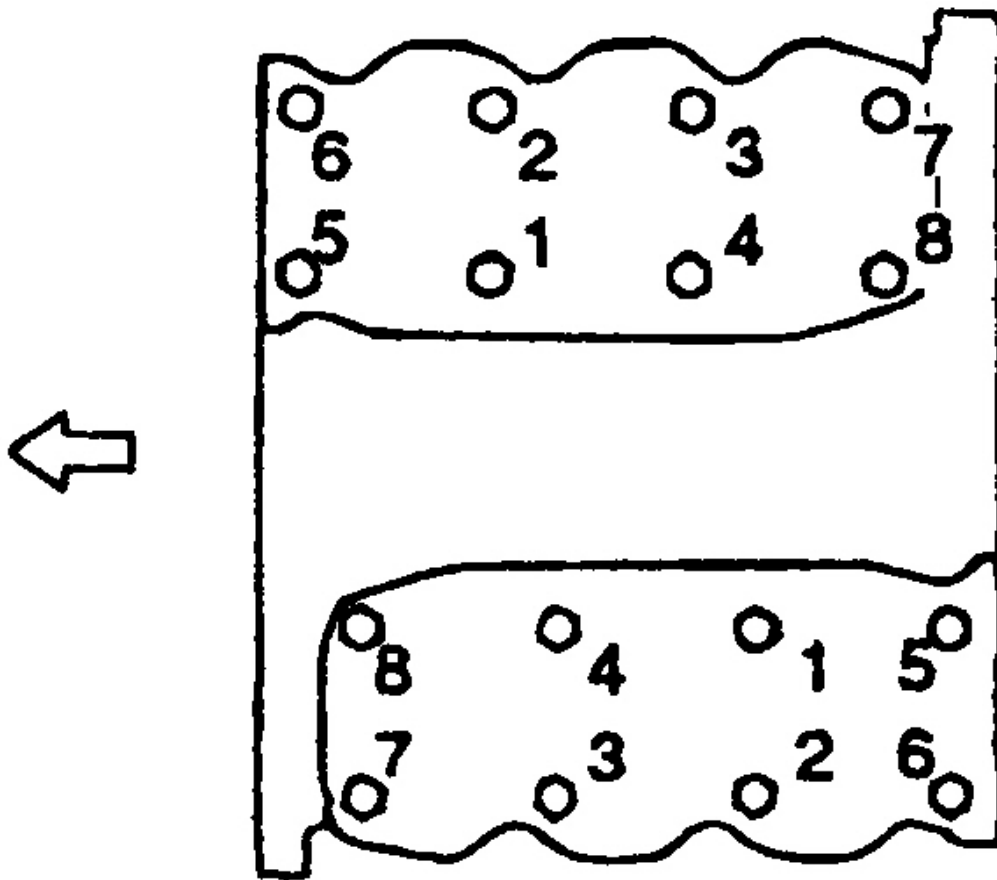

G00241075

Fig. 5: Cylinder Head Bolt Tightening Sequence
Courtesy of KIA MOTORS AMERICA, INC.

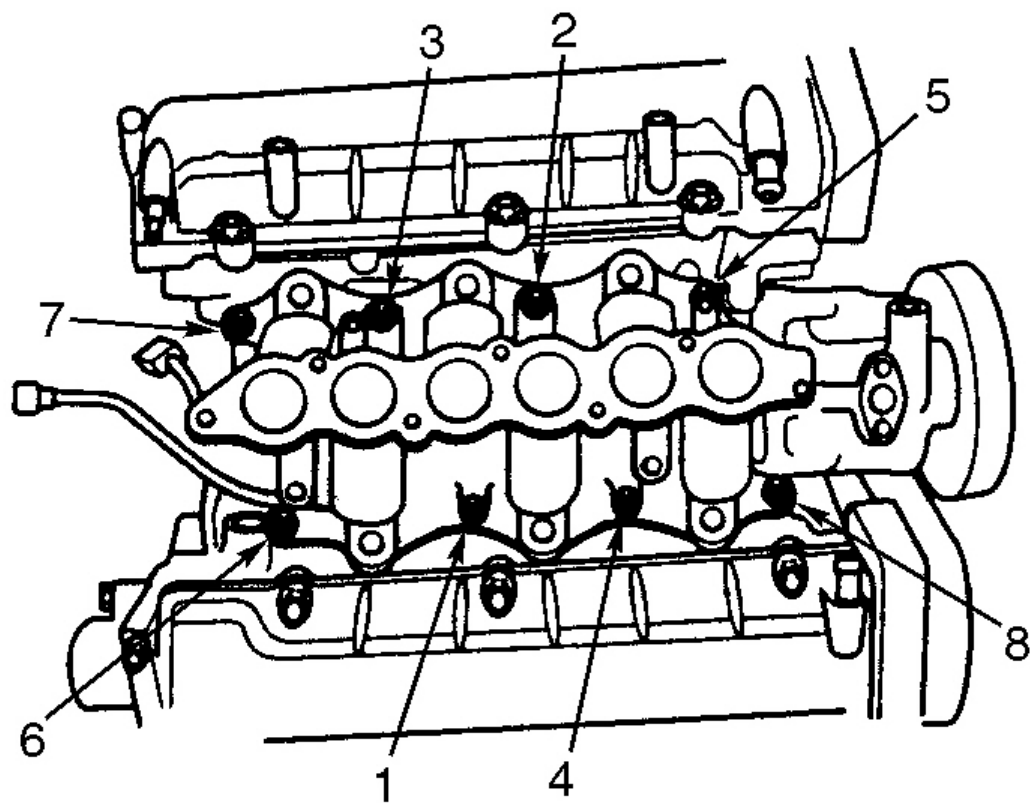

G00351841

Fig. 6: Intake Manifold Nut Tightening Sequence
Courtesy of KIA MOTORS AMERICA, INC.

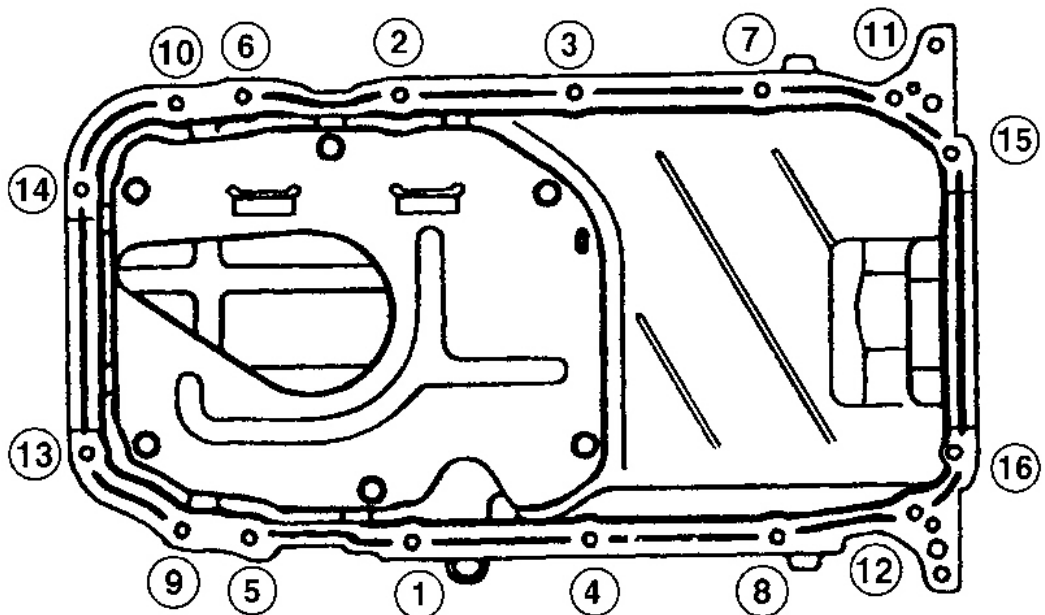

G00241076

Fig. 7: Upper Oil Pan Bolt Tightening Sequence
Courtesy of KIA MOTORS AMERICA, INC.

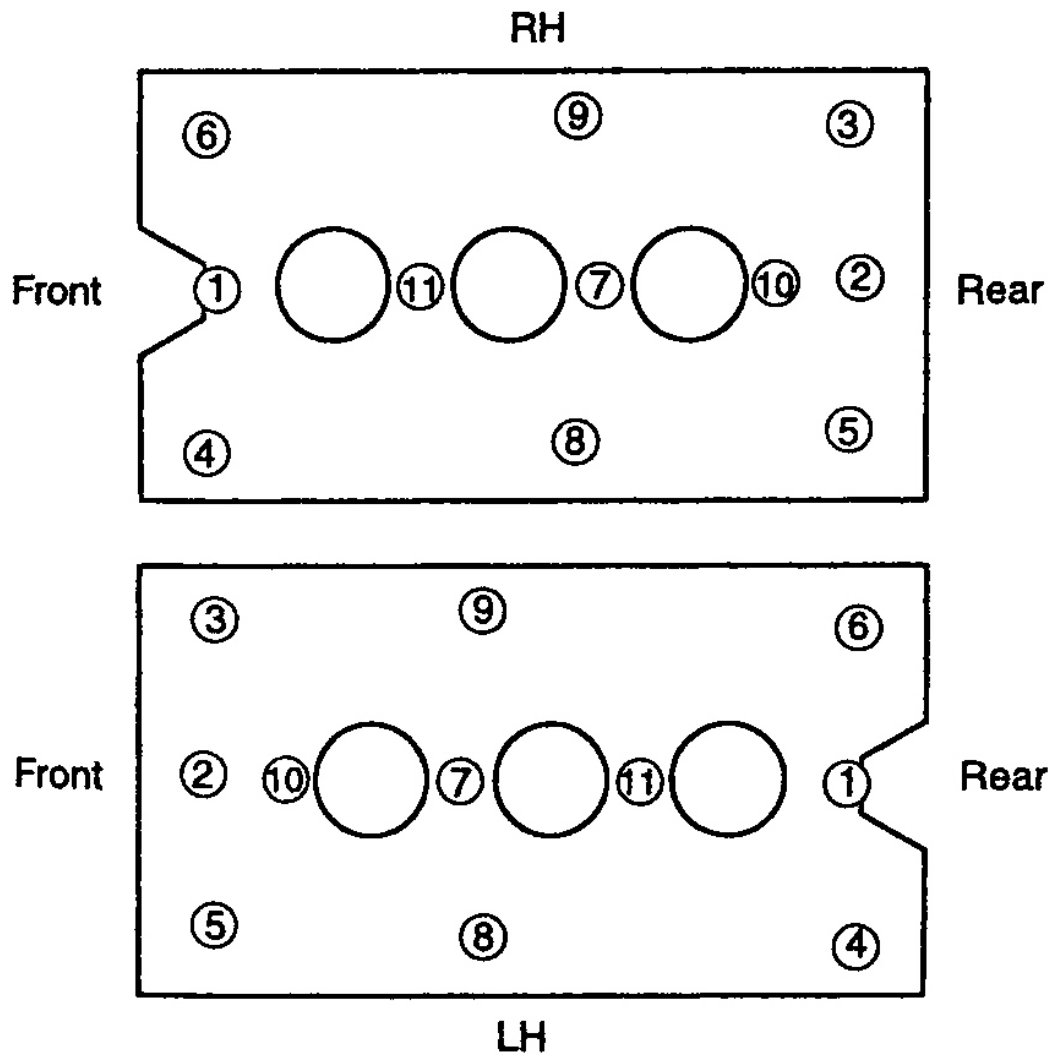

G00241078

Fig. 8: Cylinder Head Cover Bolt Tightening Sequence
 Courtesy of KIA MOTORS AMERICA, INC.

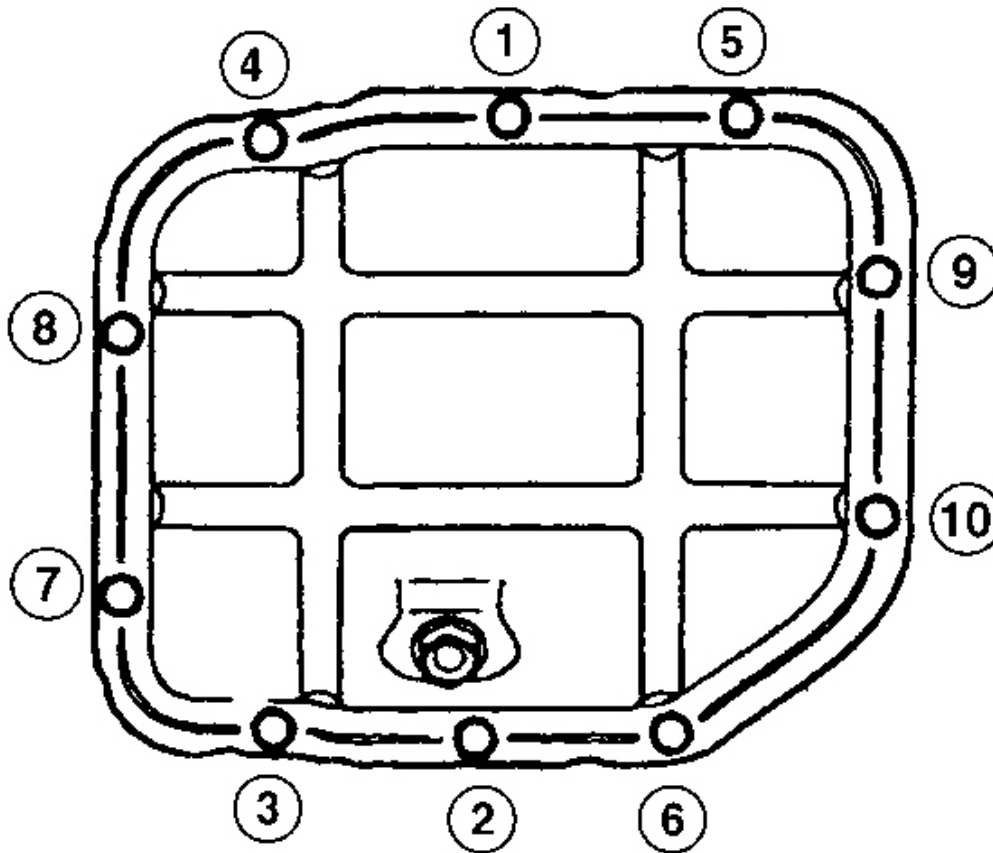

G00241077

Fig. 9: Lower Oil Pan Bolt Tightening Sequence
 Courtesy of KIA MOTORS AMERICA, INC.

FLUIDS

ANTIFREEZE SERVICE STANDARD

Standard	
Antifreeze coolant concentration	40 ~ 50%

G00320515

Fig. 10: Antifreeze Service Standard Chart
 Courtesy of KIA MOTORS AMERICA, INC.

ANTIFREEZE COOLANT

Antifreeze coolant	Ethylene glycol for aluminum radiator
--------------------	---------------------------------------

G00320516

Fig. 11: Antifreeze Coolant Chart
Courtesy of KIA MOTORS AMERICA, INC.



SEALANT

Water temperature sensor and gauge unit	No.2310 of Three Bond Co. or equivalent
Rocker cover	Roctite No.5699 or Three Bond No. 1141E
PCV valve	Loctite No. 242 or equivalent

G00320517

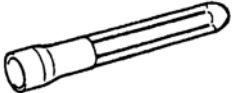
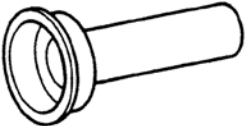
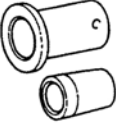
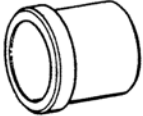

Fig. 12: Sealant Chart
Courtesy of KIA MOTORS AMERICA, INC.

SPECIAL SERVICE TOOLS

Tool (Number and name)	Illustration	Use
Valve spring compressor (09222-28000) (09222-28100)		Removal and installation of intake and exhaust valve
Valve stem oil seal installer (09222-22001)		Installation of valve stem oil seal
Valve guide installer (09222-22000(B)) (09221-29000(A))		Removal and installation of valve guide

G00368057

Fig. 13: Special Service Tools
Courtesy of KIA MOTORS AMERICA, INC.

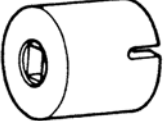
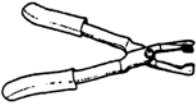
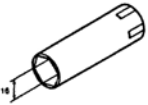
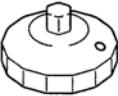
Tool (Number and name)	Illustration	Use
09231-33000 Crankshaft rear oil seal installer		Installation of crankshaft rear oil seal
09214-33000 Crankshaft front oil seal installer		Installation of crankshaft front oil seal
09221-21000 Camshaft oil seal installer		Installation of camshaft oil seal
09234-33001 Piston pin remover and installer		Removal and installation of piston pin
09231-33100 Crankshaft wrench		Used if the crankshaft needs to be rotated to attach the timing belt, etc.
09222-29000 Valve stem oil seal remover		Removal of valve stem oil seal
09188-38000 Spark plug socket wrench		Installation and removal of spark plug
09263-38000 Oil filter wrench		Removal of oil filter

G00368058

Fig. 14: Special Service Tools
Courtesy of KIA MOTORS AMERICA, INC.

CHECKING COMPRESSION PRESSURE

1. Before checking compression, check the engine oil level and that the starter motor and battery are all in normal operating condition.
2. Start the engine and wait until engine coolant temperature has risen to 80-95°C
3. Stop the engine and disconnect the spark plug cables.

4. Remove the spark plugs.
5. Turn over the engine to remove any foreign objects in the cylinders.
6. Attach the compression gauge to the spark plug hole.
7. Depress the accelerator pedal to fully open the throttle valve.
8. Turn over the engine and read the gauge.

Standard value: 1,200 kPa (12.2 kg.cm² , 170 psi)

Limit: 1,050 kPa (10.7 kg.cm² , 149 psi)

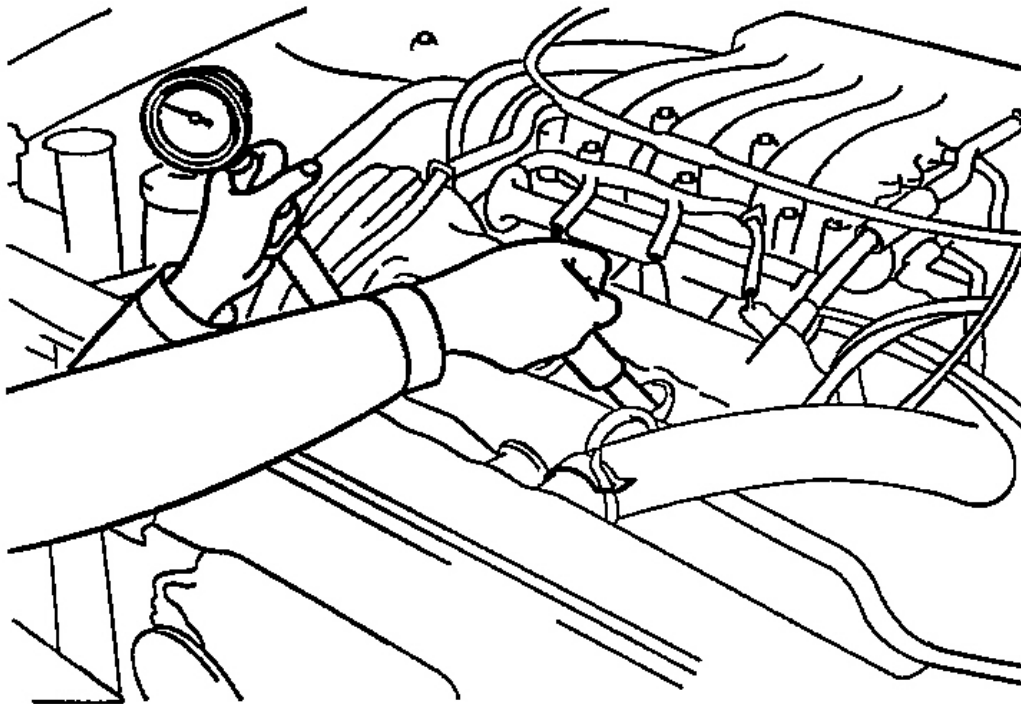

G00320523

Fig. 15: Testing Compression
Courtesy of KIA MOTORS AMERICA, INC.

9. Repeat steps 6 through 8 on all cylinders, making sure ensuring that the pressure difference for each of the cylinders is within the specified limit.

Limit: Max 100 kPa (1.0 kg/cm² , 14 psi) for all cylinders.

10. If a cylinder's compression or pressure difference is below the specification, add a small amount of oil through the spark plug hole and repeat steps 6 through 9 .
 - a. If the addition of oil causes the compression to rise, it is possible that there is wear between the piston ring and cylinder wall.
 - b. If the compression doesn't rise, valve seizure, poor valve seating or a compression leak from the cylinder head gasket are all possible causes.

Spark plug tightening torque: 20-30 N.m (200 - 300 kg.cm, 14.75 - 22.13 lb.ft.)

ENGINE OIL

CHECKING ENGINE OIL

1. Position vehicle on a level surface
2. Stop the engine

CAUTION: In the case of a vehicle that has been out of service for a prolonged period, run the engine for several minutes. Stop the engine and wait a few minutes, then check the oil level.

3. If the oil is found to have fallen to the lower limit (the L mark), refill to the (F) mark.

CAUTION: When filling, use the same type of engine oil as the one currently being used.

4. Check that the oil is not dirty or mixed with coolant or gasoline, and that it has the proper viscosity.

SELECTION OF ENGINE OIL

- Recommended API classification : SD or above.
- Recommended SAE viscosity grades :

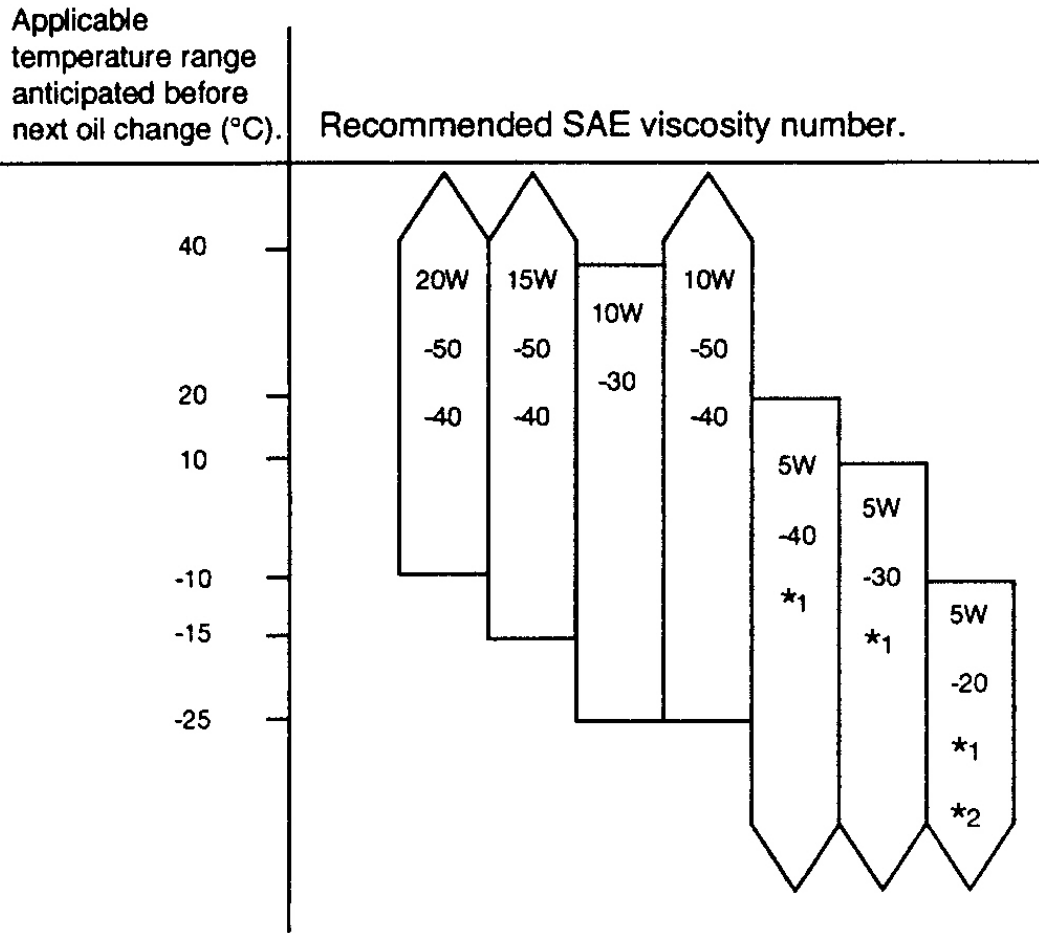

*1. Restricted by driving & climate condition.

*2. Not recommended for sustained high speed vehicle operation.

G00368060

Fig. 16: Recommended Oil Viscosity Chart
 Courtesy of KIA MOTORS AMERICA, INC.

NOTE: For best performance and for maximum protection for all types of operation, select only those lubricants which:

- a. Confirm to the requirements of the API classification.
- b. Have proper SAE grade number for expected ambient temperature range. Lubricants which do not have both an SAE grade number and an API service classification on the container should not be used.

CHANGING ENGINE OIL

1. Run the engine until it reaches normal operating temperature.
2. Stop the engine.
3. Remove the oil filler cap and the drain plug. Drain the engine oil.

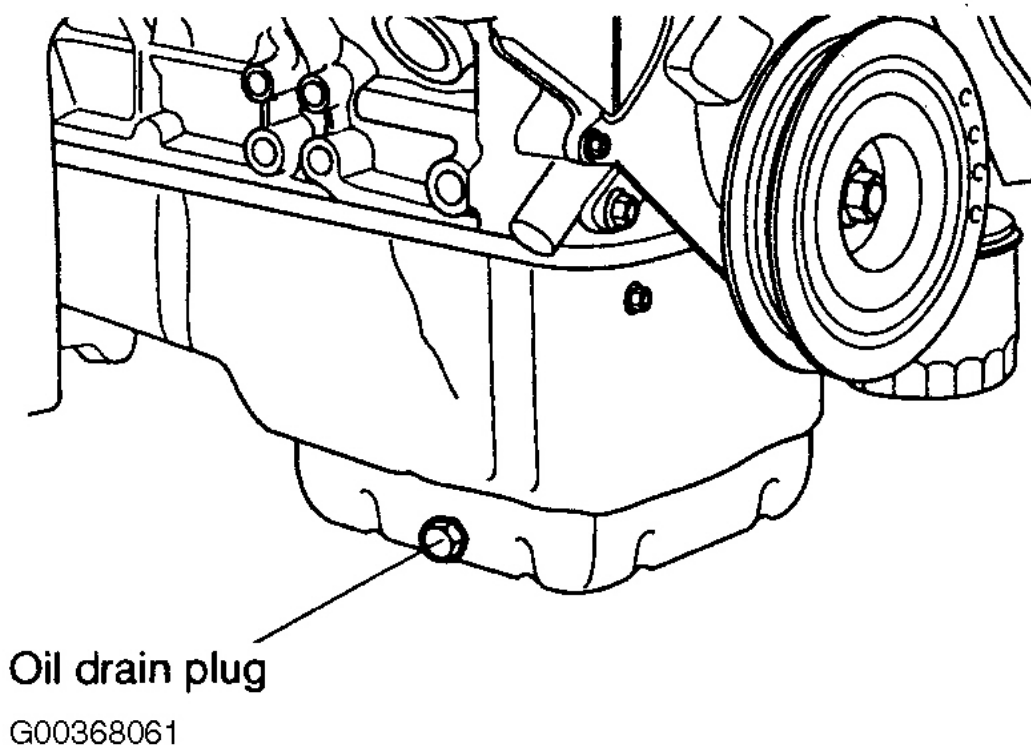

Fig. 17: Identifying Oil Drain Plug
Courtesy of KIA MOTORS AMERICA, INC.

4. Tighten the drain plug to the specified torque. 26-30 ft.lbs. (35-45 N.m).

CAUTION: Whenever tightening an oil drain plug, use a new drain plug gasket.

5. Install oil filter.
6. Fill the engine with new engine oil through the oil filling hole. Amount of oil 4.5 qts (4.3Liters))

CAUTION: Do not overfill the crankcase. This will cause oil aeration and loss of oil pressure.

7. Reinstall the oil filler cap.
8. Start the engine.
9. Stop the engine and check the oil level. If not sufficient, refill engine.

REPLACING OIL FILTER

All Kia Motor Company engines are equipped with a quality, throw-away oil filter. This filter is recommended as a replacement filter on all vehicles. The quality of replacement filters varies considerable. Only high quality filters should be used to assure the most efficient service. Make sure that the rubber gasket from the old filter is completely removed from the mating surfaces on the engine block, before installing the new filter.

1. Use a filter wrench to remove the oil filter.
2. Before installing the new oil filter on the engine, apply clean engine oil to the surface of the rubber gasket.

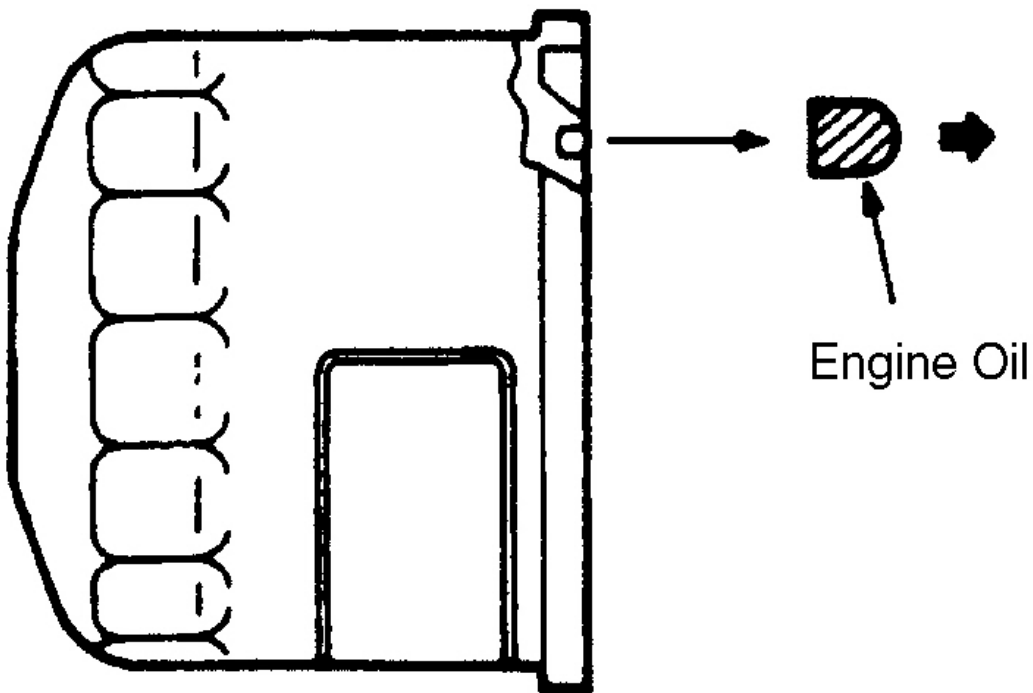

G00368062

Fig. 18: Illustrating Oil filter
Courtesy of KIA MOTORS AMERICA, INC.

3. Tighten the oil filter to the specified amount. 13-18 ft.lbs. (17-25 N.m))
4. Fill the engine with engine oil.
5. Start and run the engine and check for oil leaks.
6. After stopping the engine, check the oil level and add as much oil as necessary.

OIL PRESSURE SWITCH

1. If "OIL PRESSURE" indicating lamp lights when ignition switch is set to "ON" and goes out when engine is started and runs at idle, then everything is in order. If "OIL PRESSURE" lamp does not light when ignition switch is set to "ON" check switch, lamp and wiring.
2. If there is current flow when ignition switch is set to "ON" and if there is no current flow when engine is running at idle, switch is good.

If switch is good, check lamp and wiring.

Operating pressure of oil pressure switch: 19.6 - 39.2 kPa (0.2 - 0.4 kg.cm² , 2.84 - 5.69 psi)

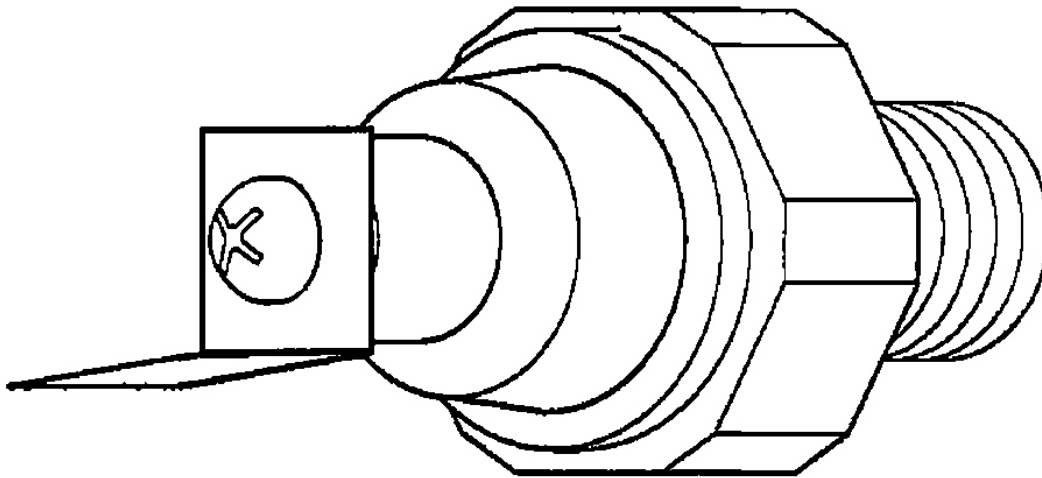

G00320624

Fig. 19: Illustrating Oil Pressure Switch
Courtesy of KIA MOTORS AMERICA, INC.

3. Using 24 mm deep socket, tighten the switch to the specified torque.

NOTE: Do not tighten the oil pressure switch to the excessive torque.

Tightening torque

Oil pressure switch and sensor assembly: 8-12 N.m (80~120 kg.cm, 5.91-8.85 lb.ft)

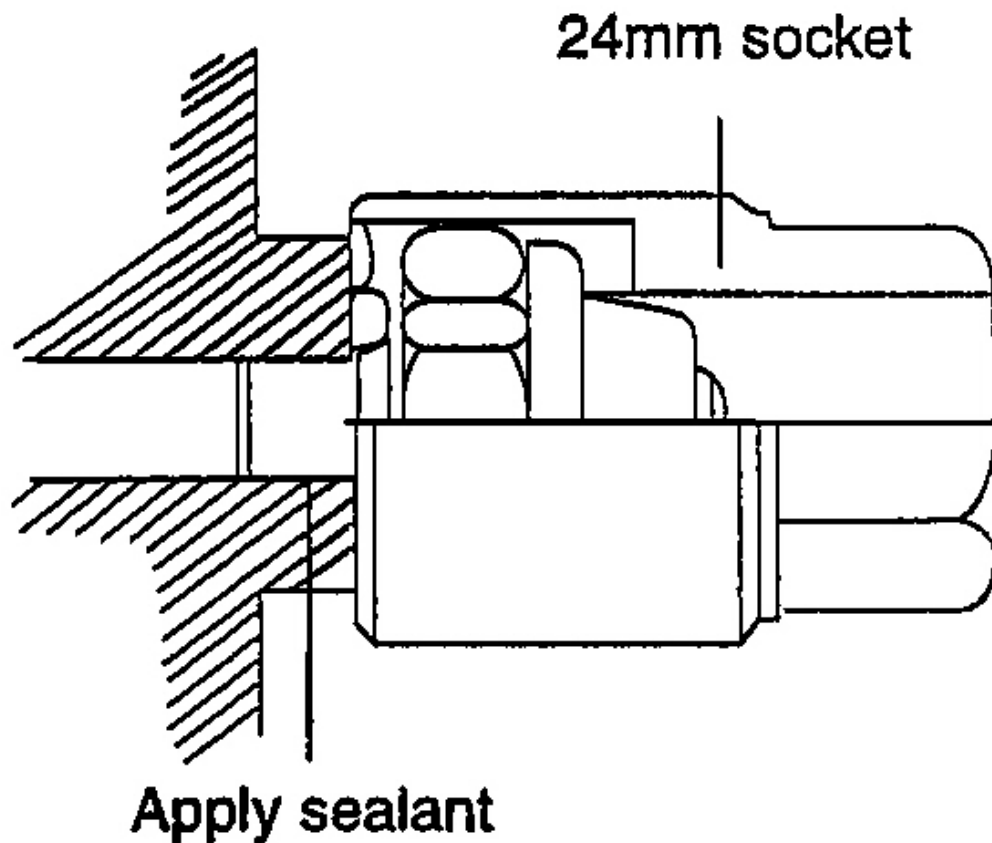

G00320625

Fig. 20: Removing & Installing Oil Pressure Switch
Courtesy of KIA MOTORS AMERICA, INC.

DRIVE BELT ROUTING

1. For power steering belt routing, see **Fig. 21** .
2. For air conditioning compressor and alternator belt routing, see **Fig. 22** .
3. For combined belt routing, see **Fig. 23** .

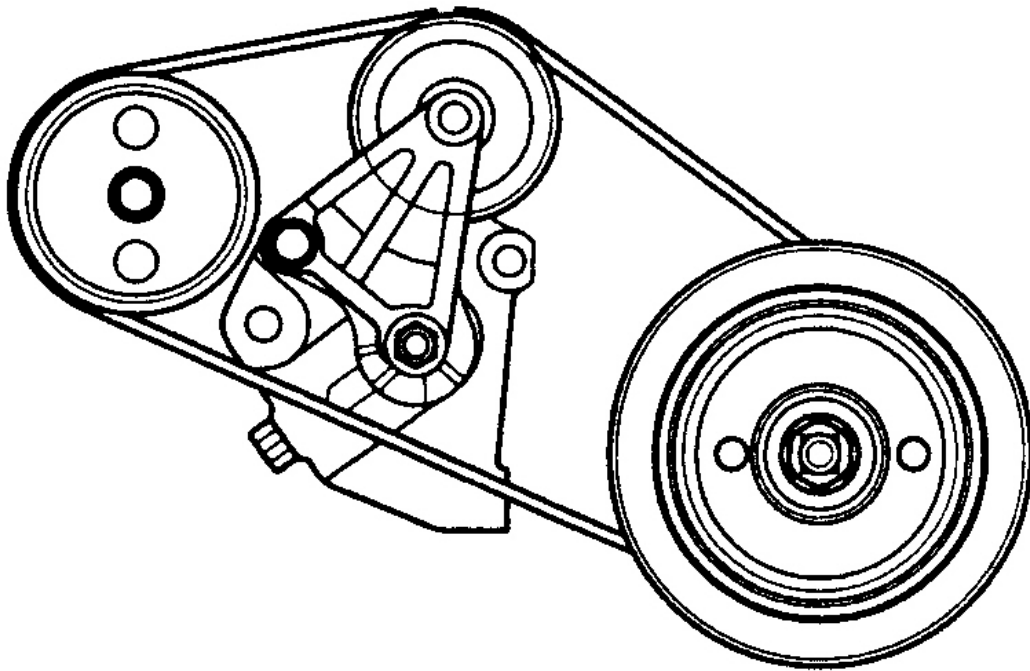

G00323197

Fig. 21: Power Steering Belt Routing
Courtesy of KIA MOTORS AMERICA, INC.

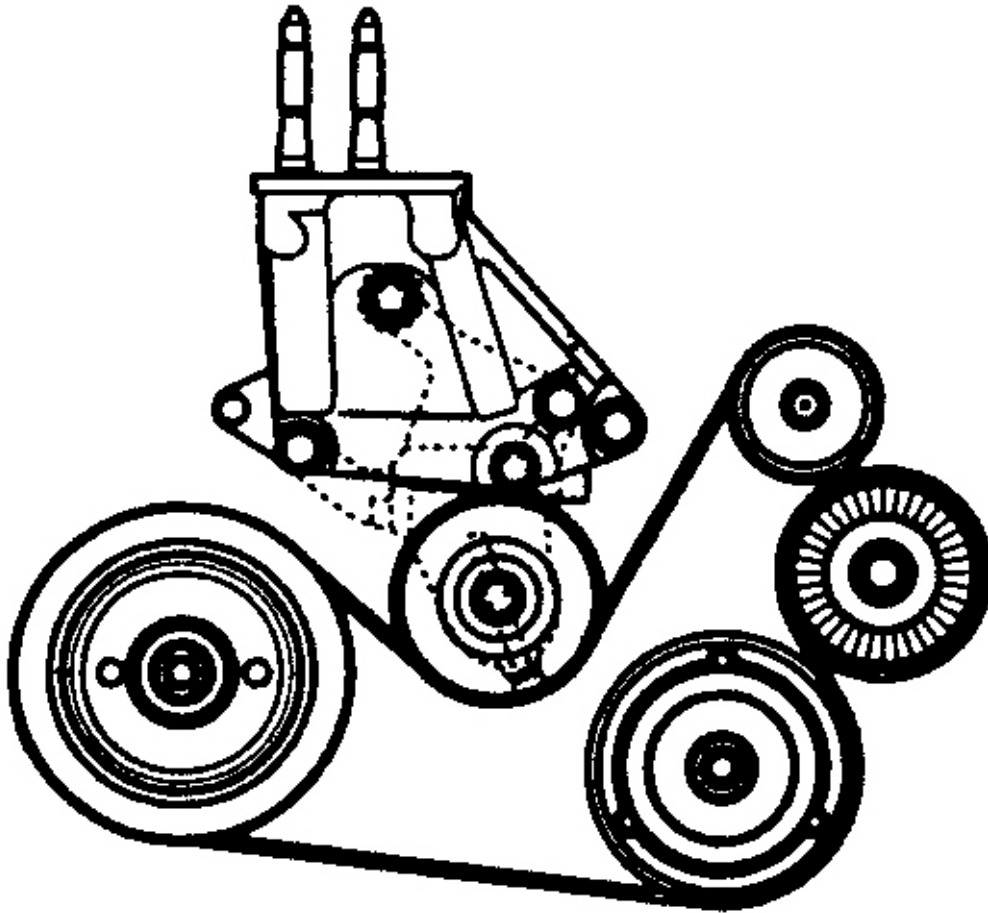

G00323203

Fig. 22: Air Conditioning Compressor & Alternator Belt Routing
Courtesy of KIA MOTORS AMERICA, INC.

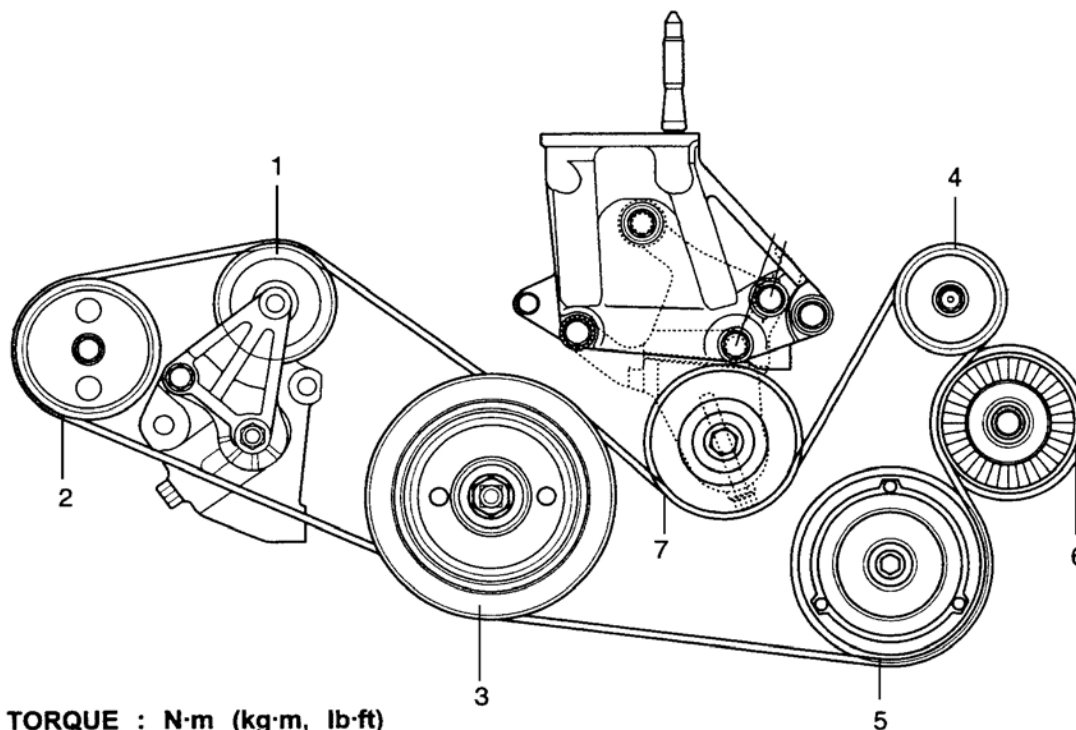

TORQUE : N·m (kg·m, lb·ft)

- | | |
|--------------------------|---------------------------|
| 1. Tension pulley | 5. Air conditioner pulley |
| 2. Power steering pulley | 6. Idler pulley |
| 3. Crankshaft pulley | 7. Tension pulley |
| 4. Alternator pulley | |

G00323228

Fig. 23: Combined Drive Belt Routing
 Courtesy of KIA MOTORS AMERICA, INC.

DRIVE BELT ADJUSTMENT

Power Steering

1. Loosen hinge bolt "A" and flange nut "B". See **Fig. 24** .
2. Turn adjusting bolt "C" to set belt tension to specified deflection. See **Fig. 24** and **Fig. 25** . See **BELT ADJUSTMENT** table.
3. Tighten hinge bolt "A" and flange nut "B" to specification. See **TORQUE SPECIFICATIONS** table.

Alternator & Air Conditioning Compressor

1. Loosen pulley lock nut "A". See **Fig. 26** .
2. Turn adjustment bolt "B" to set belt tension to specified deflection. See **Fig. 26** and **Fig. 27** . See **BELT ADJUSTMENT** table.
3. Tighten pulley lock nut "A" to specification. See **TORQUE SPECIFICATIONS** table.

4. Start engine and turn A/C on.
5. Allow vehicle to run until normal operating temperature is reached.
6. Turn engine off, recheck belt deflection after operation and readjust belt tension as necessary. See **BELT ADJUSTMENT** table.

BELT ADJUSTMENT

Application	(1) Deflection - In. (mm)
Alternator & Air Conditioning Compressor	
New Belt Deflection	.20-.22 (5-5.5)
Used Belt Deflection	.24-.28 (6-7)
After Operation	.31 (8)
Power Steering	
New Belt Deflection	.35-.43 (9-11)
Used Belt Deflection	.47-.59 (12-15)

(1) Deflection is measured at the contact point with 22 lbs. (10 kg) of deflection force.

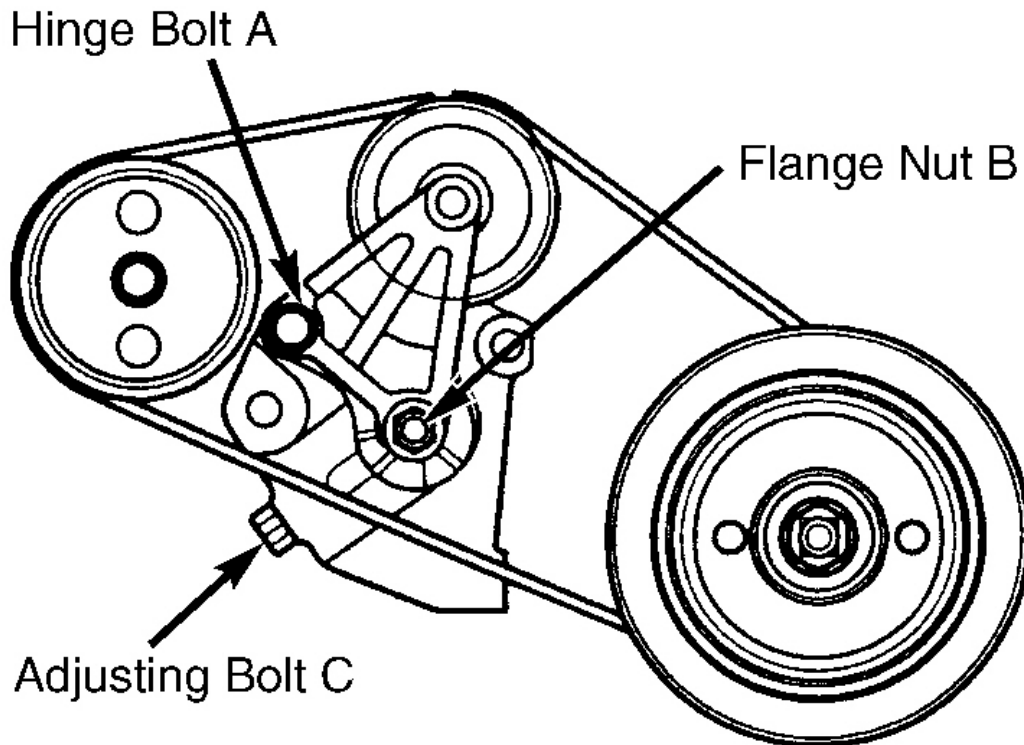

G00323204

Fig. 24: Adjusting Power Steering Belt Tension
Courtesy of KIA MOTORS AMERICA, INC.

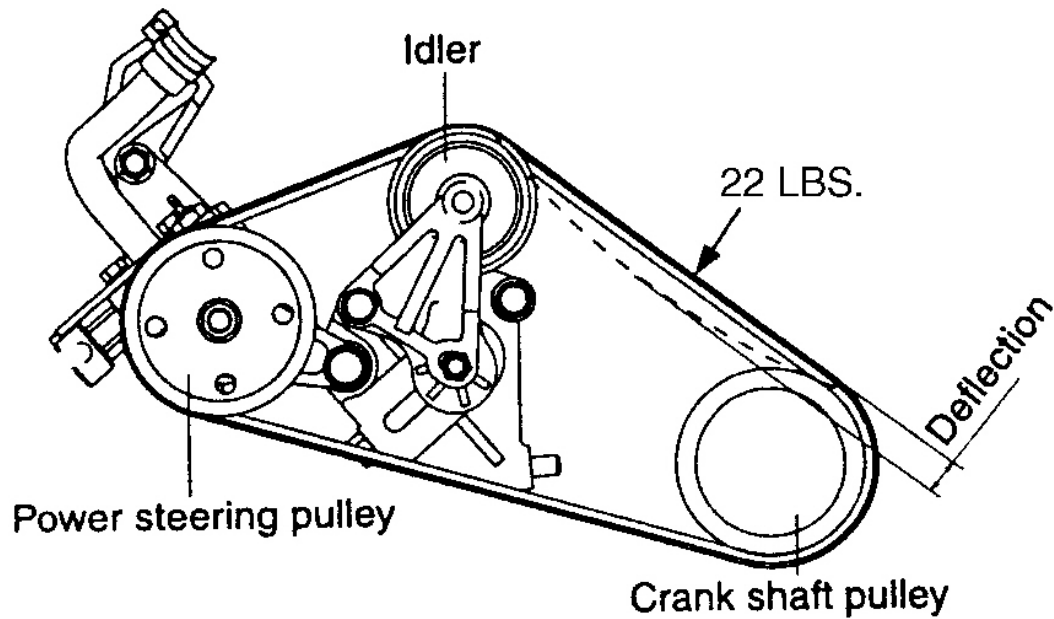

G00323208

Fig. 25: Measuring Power Steering Belt Deflection
Courtesy of KIA MOTORS AMERICA, INC.

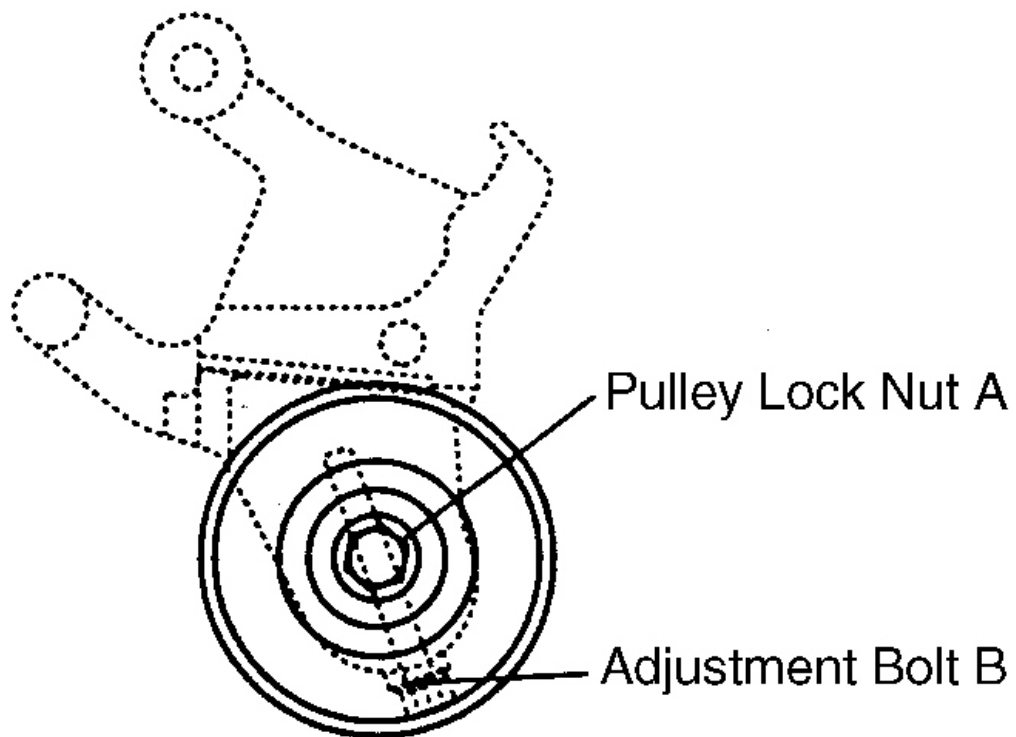

G00323207

Fig. 26: Adjusting Alternator & Air Conditioning Compressor Belt
Courtesy of KIA MOTORS AMERICA, INC.

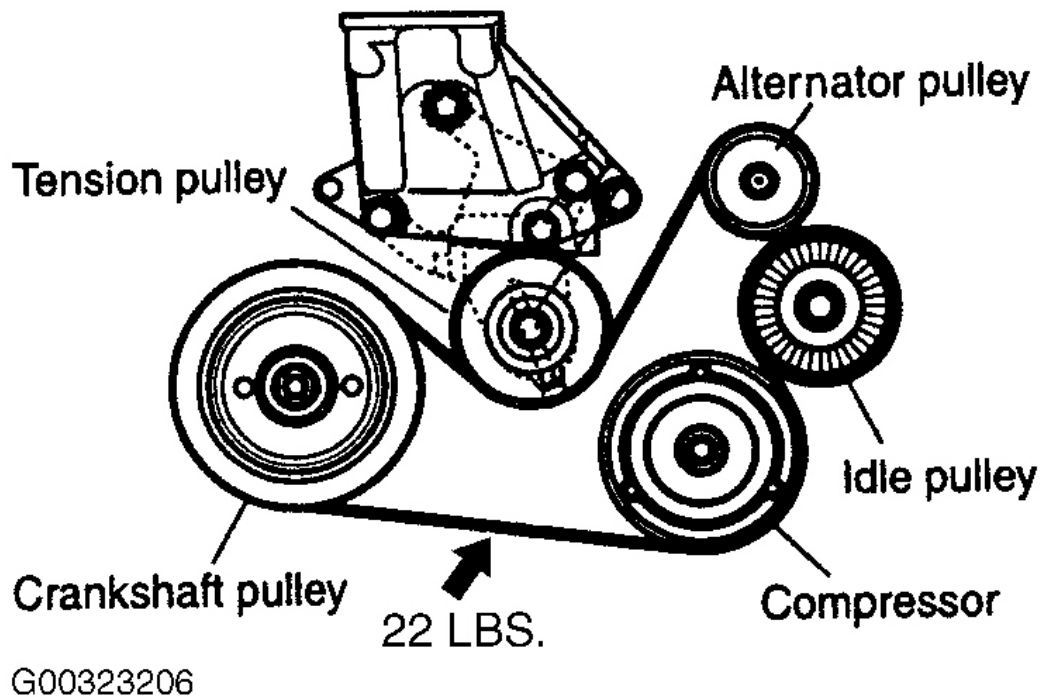
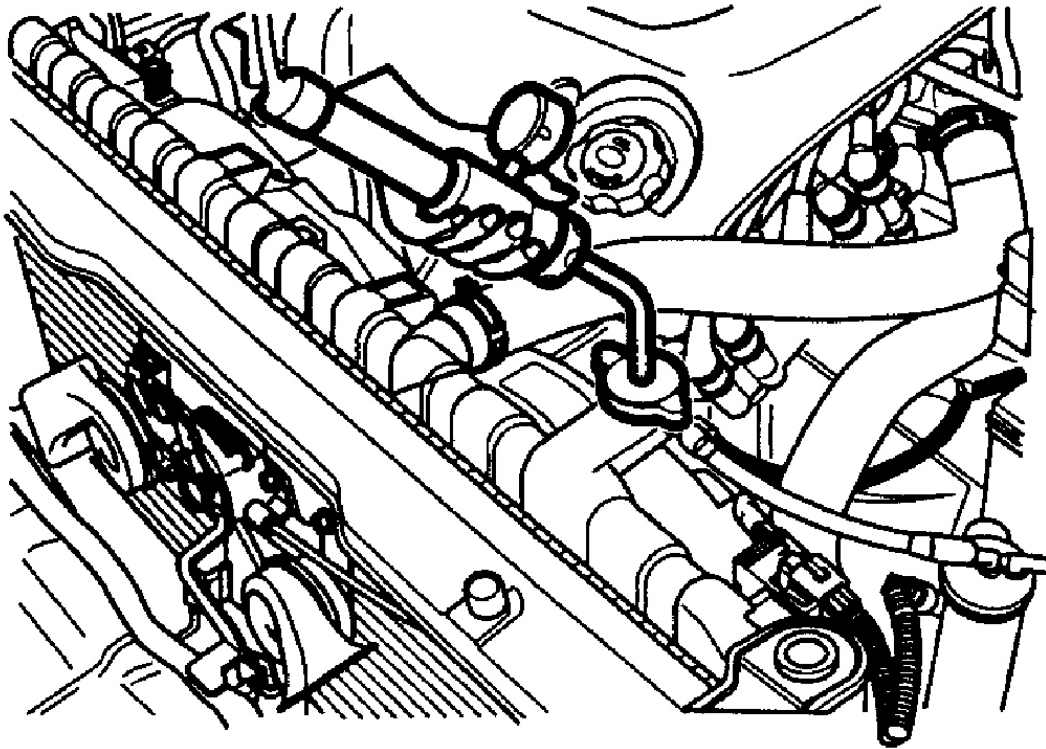

Fig. 27: Measuring Alternator & Air Conditioning Compressor Belt Deflection
Courtesy of KIA MOTORS AMERICA, INC.

COOLANT LEAK CHECK

1. Loosen the radiator cap.
2. Confirm that the coolant level is up to the filler neck.
3. Install a radiator cap tester to the radiator filler neck and apply 22 lbs. of pressure. Hold for two minutes in that condition, while checking, hose connections.



G00368063

Fig. 28: Pressure Testing Radiator
Courtesy of KIA MOTORS AMERICA, INC.

CAUTION:

- Radiator coolant may be extremely hot. Do not open the system while hot, or scalding. Engine coolant could spray out causing personal injury. Allow the vehicle to cool before servicing this system.
- Be sure to completely clean away any moisture from the places checked.
- When the tester is removed, be careful not to spill any coolant from tester.
- Be careful, when installing and removing the tester and when testing, not to deform the filler neck of the radiator.

4. If there is any leakage, repair or replace the appropriate part.

RADIATOR CAP PRESSURE TEST

1. Use an adapter to attach the cap to tester.

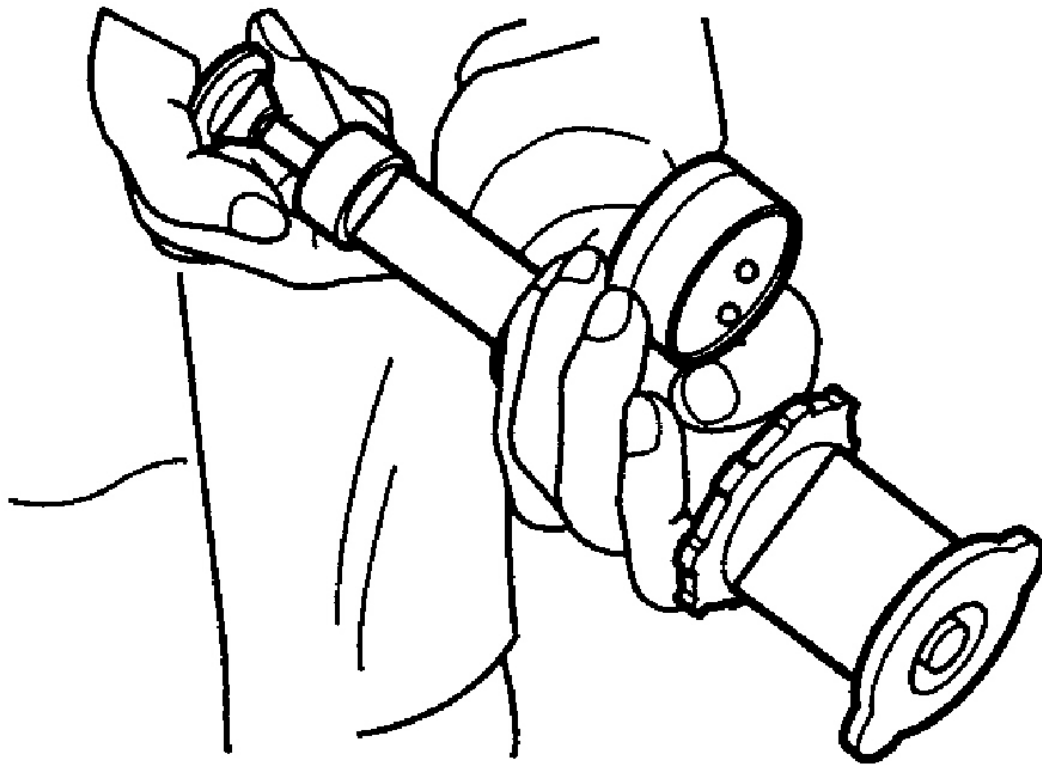

G00368064

Fig. 29: Testing Radiator Cap
Courtesy of KIA MOTORS AMERICA, INC.

2. Increase the pressure until the gauge indicator stops moving.
 - Main valve opening pressure: 14-18 psi (86-125 kPa).
 - Main valve closing pressure: 12 psi (83 kPa)
3. Check that the pressure level is maintained at or above the limit.
4. Replace that radiator cap if the reading does not remain at or above the limit.

NOTE: Be sure that the cap is clean before testing, since rust or other foreign material on the cap seal will cause an improper reading.

SPECIFIC GRAVITY TEST

1. Measure the specific gravity of the coolant with a hydrometer.
2. Measure the coolant temperature, and calculate the concentration from the relation between the specific gravity and temperature, using the following table for reference.

COOLING SYSTEM SPECIFICATIONS

The coolant concentration can be calculated by measuring coolant temperature and specific gravity. After coolant temperature and specific gravity is obtained, a concentration can be calculated using the following chart. See [Fig. 30](#). If the concentration of coolant is below 30 percent, the anti-corrosion property will be adversely affected. If the concentration is above 60 percent, both the antifreeze and engine cooling properties will decrease and may adversely affect the engine.

NOTE: Recommended coolant concentration is 40-50 percent, using only ethylene glycol for aluminum type coolant.

Coolant temperature °C (°F) and specific gravity					Freezing temperature °C (°F)	Safe operating temperature °C (°F)	Coolant concentration (Specific volume)
10 (50)	20 (68)	30 (86)	40 (104)	50 (122)			
1.054	1.050	1.046	1.042	1.036	-16 (3.2)	-11 (12.2)	30%
1.063	1.058	1.054	1.049	1.044	-20 (-4)	-15 (5)	35%
1.071	1.067	1.062	1.057	1.052	-25 (-13)	-20 (-4)	40%
1.079	1.074	1.069	1.064	1.058	-30 (-22)	-25 (-13)	45%
1.087	1.082	1.076	1.070	1.064	-36 (-32.8)	-31 (-23.8)	50%
1.095	1.090	1.084	1.077	1.070	-42 (-44)	-37 (-35)	55%
1.103	1.098	1.092	1.084	1.076	-50 (-58)	-45 (-49)	60%

G00323217

Fig. 30: Testing Coolant Concentration & Specific Gravity
Courtesy of KIA MOTORS AMERICA, INC.

ENGINE MOUNTING

ENGINE MOUNTS

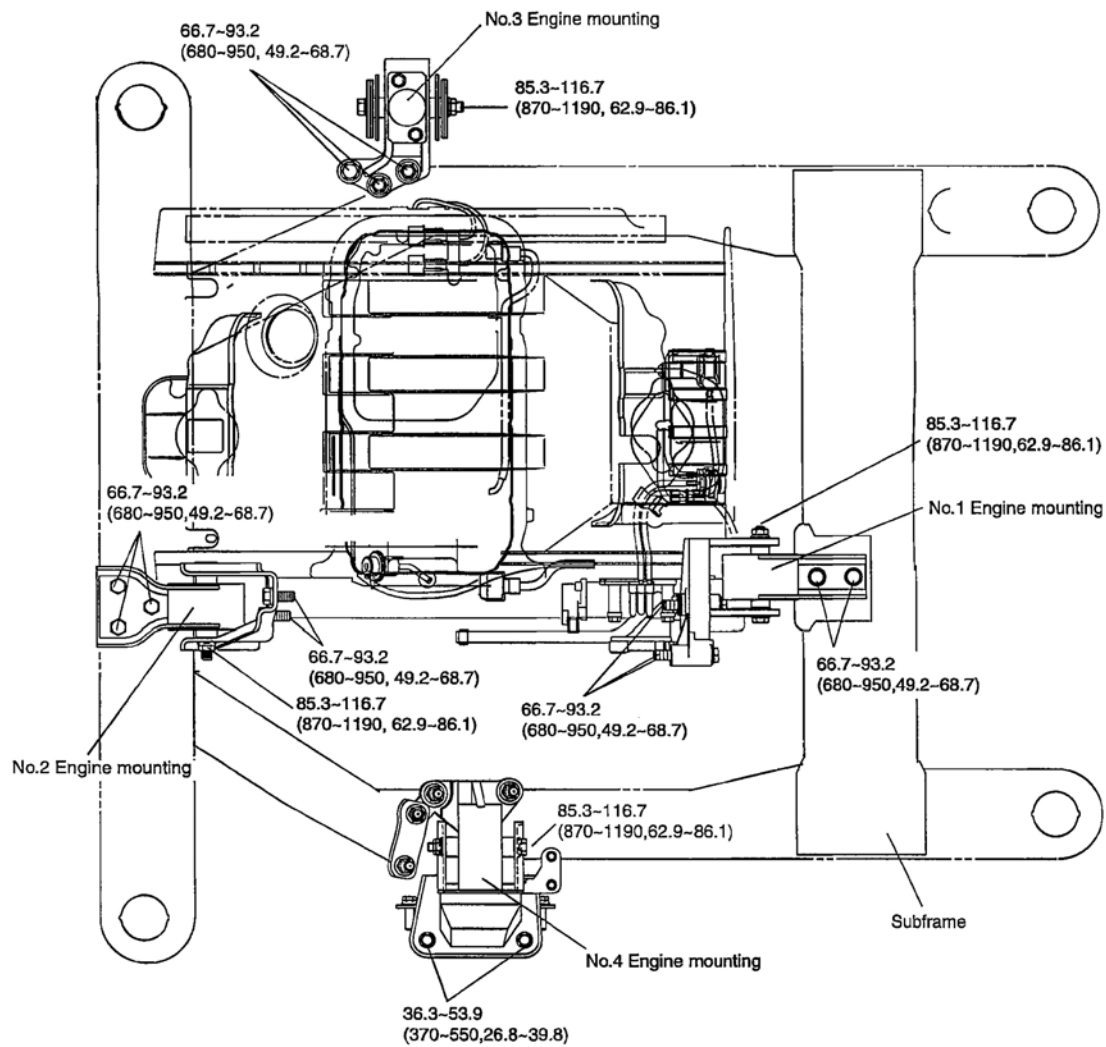

TORQUE : N·m (kg·cm, lb·ft)

G00320529

Fig. 31: Identifying Engine Mounts
 Courtesy of KIA MOTORS AMERICA, INC.

SUB FRAME MOUNTS

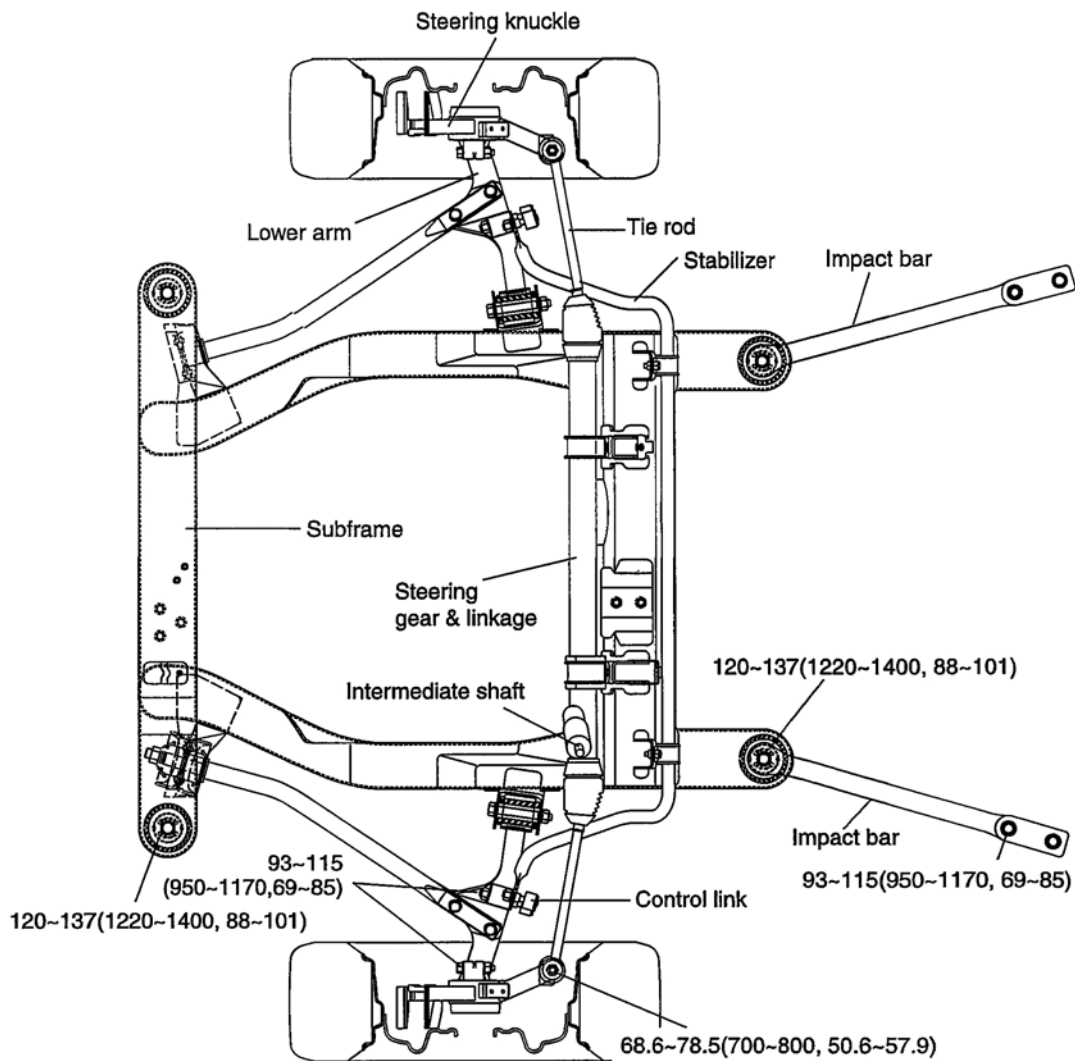

TORQUE : N-m (kg-cm, lb-ft)

G00320530

Fig. 32: Identifying Subframe Mounts
 Courtesy of KIA MOTORS AMERICA, INC.

ENGINE AND TRANSAXLE ASSEMBLY

REMOVAL

1. Remove the battery and engine cover.

2. Detach the air cleaner.
3. Disconnect the connectors for the engine harness.
4. Disconnect the connectors for the alternator harness, the oil pressure switch and the oil pressure sensor.
5. Disconnect the connector of starter motor harness.
6. Drain the engine coolant.
7. Disconnect transaxle oil cooler hose.

NOTE: **When disconnecting the hoses, make identification marks to avoid making any mistakes when re-installing them.**

CAUTION: Be careful not to spill any of the oil or fluid out of the hoses. Plug the openings to prevent the entry of foreign material.

8. Disconnect the radiator upper and lower hoses on the engine side, and then remove the radiator assembly.
9. Disconnect the high tension cable and all wires to the distributor and the ignition coil.
10. Disconnect the engine ground.
11. Disconnect the brake booster vacuum hose.
12. Disconnect the EVAP canister hose.
13. Remove the main fuel line, and the return and vapor hoses from the engine side.

CAUTION: To reduce the residual pressure in the hoses, see FUEL PRESSURE TEST.

14. Disconnect the heater hose (Intake and exhaust) at the engine side.
15. The accelerator cable should be removed from the engine side.
16. The cruise control cable should be removed from the engine side.
17. Remove the control cable from the transaxle.
18. Disconnect the speed sensor connector from the transaxle.

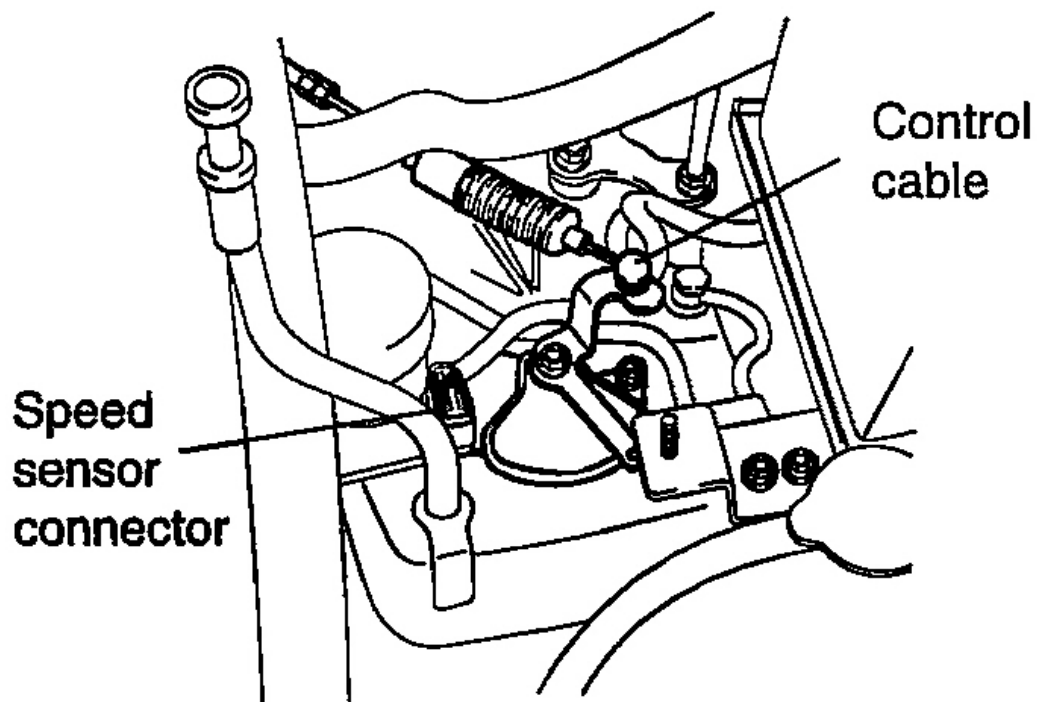

G00320531

Fig. 33: Disconnecting The Speed Sensor Connector
Courtesy of KIA MOTORS AMERICA, INC.

19. Remove the power steering oil pump hose.
20. Raise the vehicle.
21. Remove the oil pan shield.
22. Drain the transaxle oil.

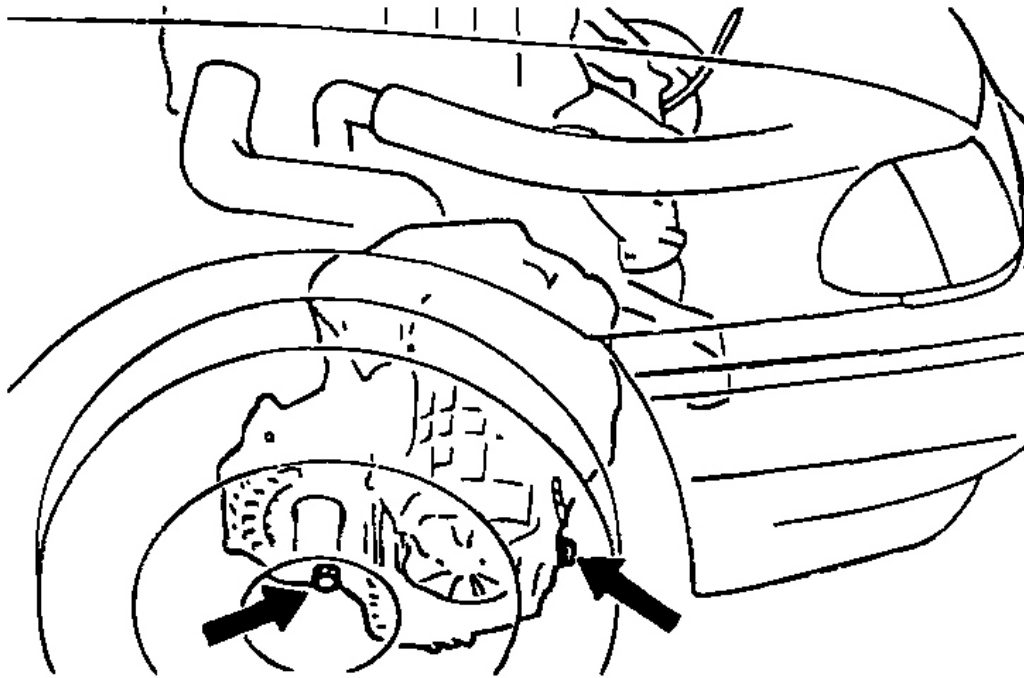

G00320532

Fig. 34: Drain The Transaxle Oil
Courtesy of KIA MOTORS AMERICA, INC.

23. Disconnect the front exhaust pipe from the manifold.

NOTE: Use a wire to suspend the exhaust pipe from the bottom of the vehicle.

24. Remove the tie rod end from steering knuckles.
25. Remove control link from stabilizer and lower arm.
26. Remove pinch bolt from knuckle. Separate lower arm form knuckle.

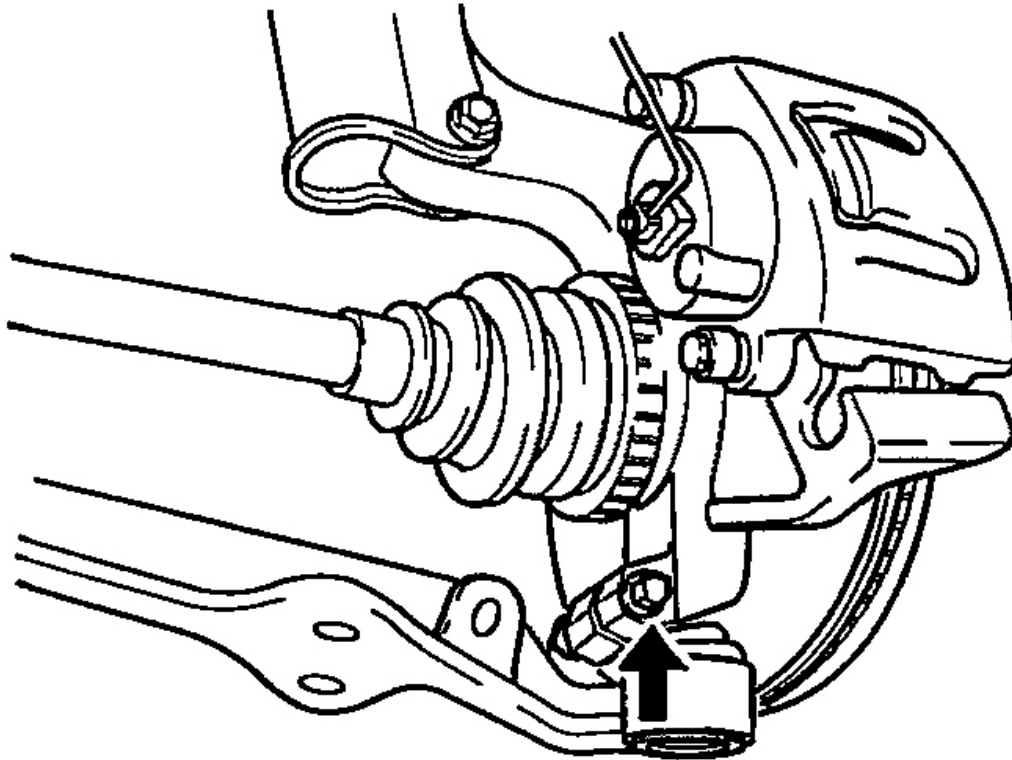

G00320533

Fig. 35: Removing Pinch Bolt From Knuckle
Courtesy of KIA MOTORS AMERICA, INC.

27. Remove the drive shaft from the transaxle housing.

CAUTION:

- Plug up the holes of the transaxle case to prevent entry of foreign material.
- The circlips on the drive shafts should be replaced whenever reinstalling.

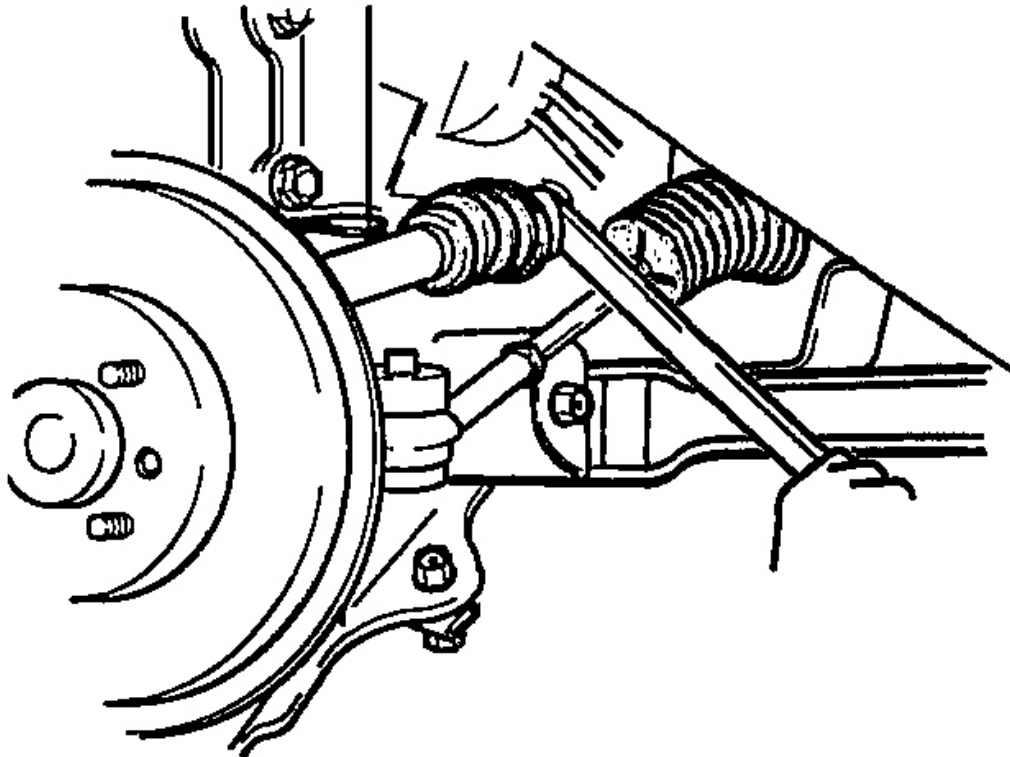

G00320534

Fig. 36: Removing The Drive Shaft From The Transaxle Housing
Courtesy of KIA MOTORS AMERICA, INC.

28. Remove intermediate shaft bolt. See **REMOVAL** .
29. Remove No. 3, No. 4 engine mounting.
30. Support auto transaxle, engine and subframe with a suitable floor jack.

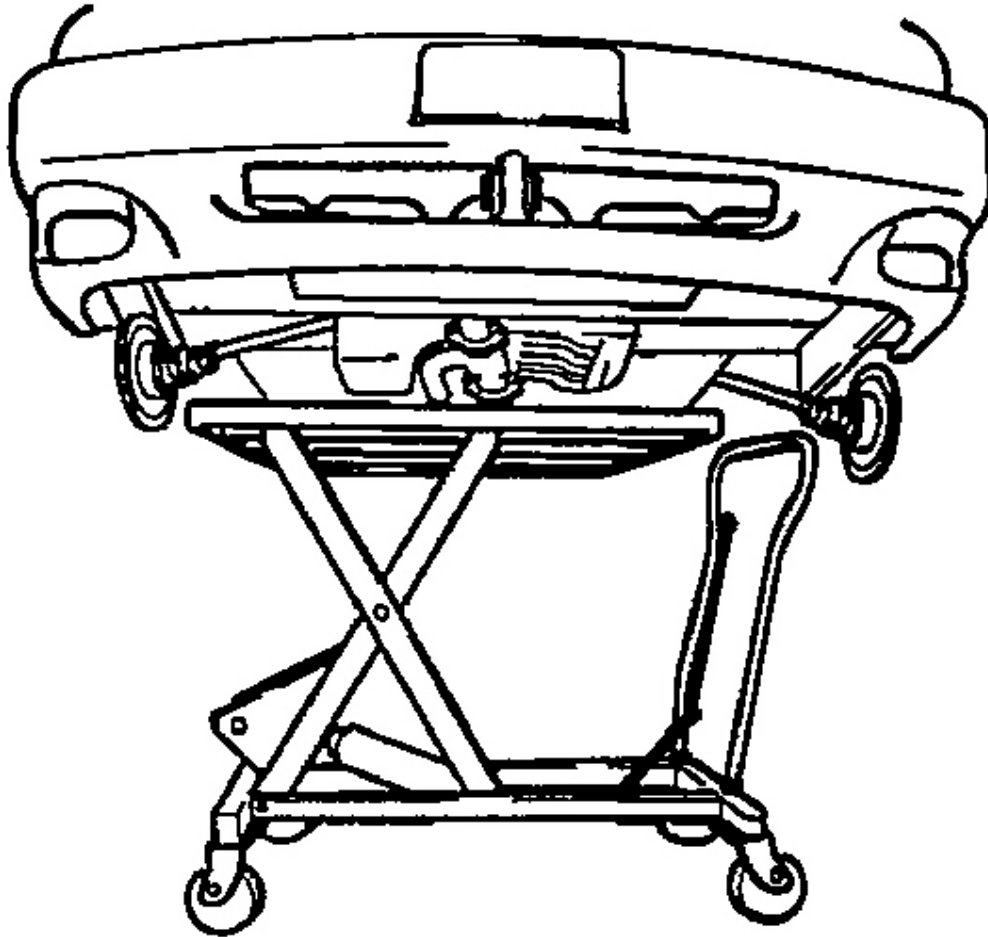

G00320535

Fig. 37: Support Auto Transaxle, Engine & Subframe With A Suitable Floor Jack
Courtesy of KIA MOTORS AMERICA, INC.

31. Remove nuts and bolts of impact bar and subframe.
32. Slowly lower engine, auto transaxle and subframe.
33. Remove No. 1, No. 2 engine mounting from subframe.
34. Separate auto transaxle from engine.

TIMING SYSTEM

TIMING BELT

COMPONENTS

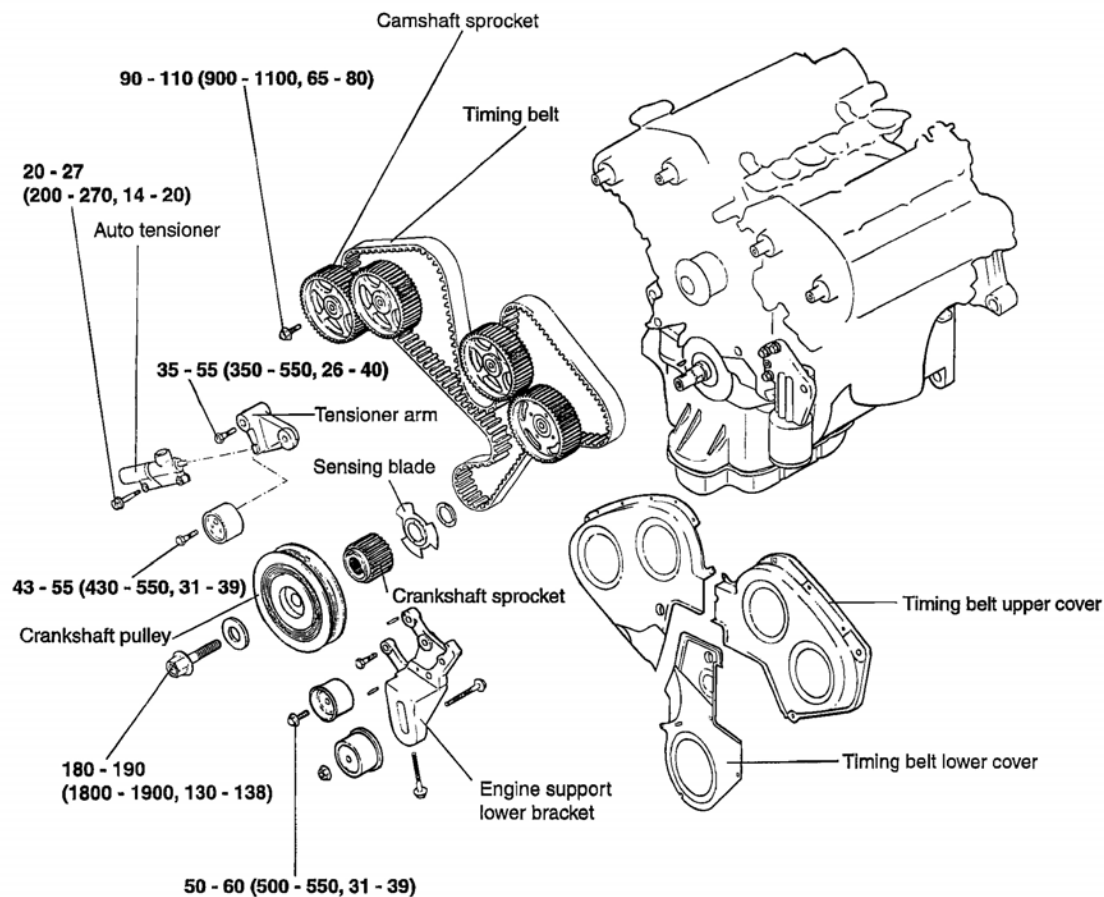

TORQUE : Nm (kg.cm, lb.ft)

G00320682

Fig. 38: Identifying Timing System Components
Courtesy of KIA MOTORS AMERICA, INC.

REMOVAL

1. Remove the engine cover.
2. Remove the drive belt.
3. Remove the idler pulley, crankshaft pulley, power steering pulley and tensioner pulley.

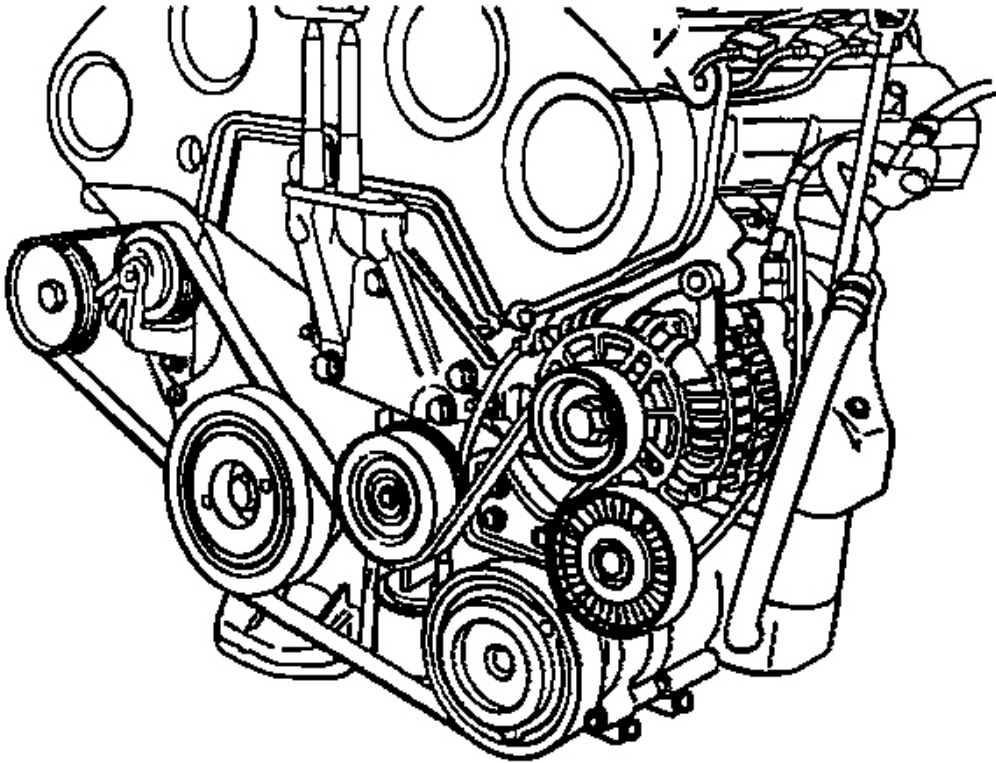

G00320684

Fig. 39: Identifying Belt Routing
Courtesy of KIA MOTORS AMERICA, INC.

4. Remove the upper and lower timing belt cover.

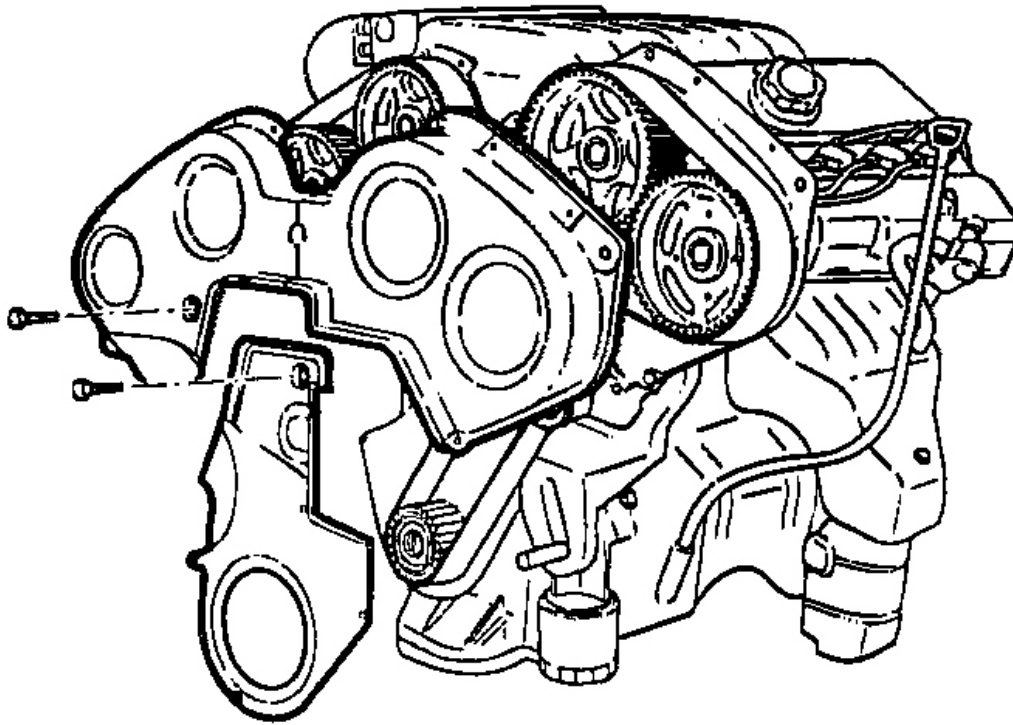

G00320685

Fig. 40: Removing The Upper & Lower Timing Belt Cover
Courtesy of KIA MOTORS AMERICA, INC.

5. Support the engine with garage jack or special tool, and then remove the engine mounting insulator.

CAUTION: Take care not to deform the engine oil pan.

6. Remove the auto tensioner.

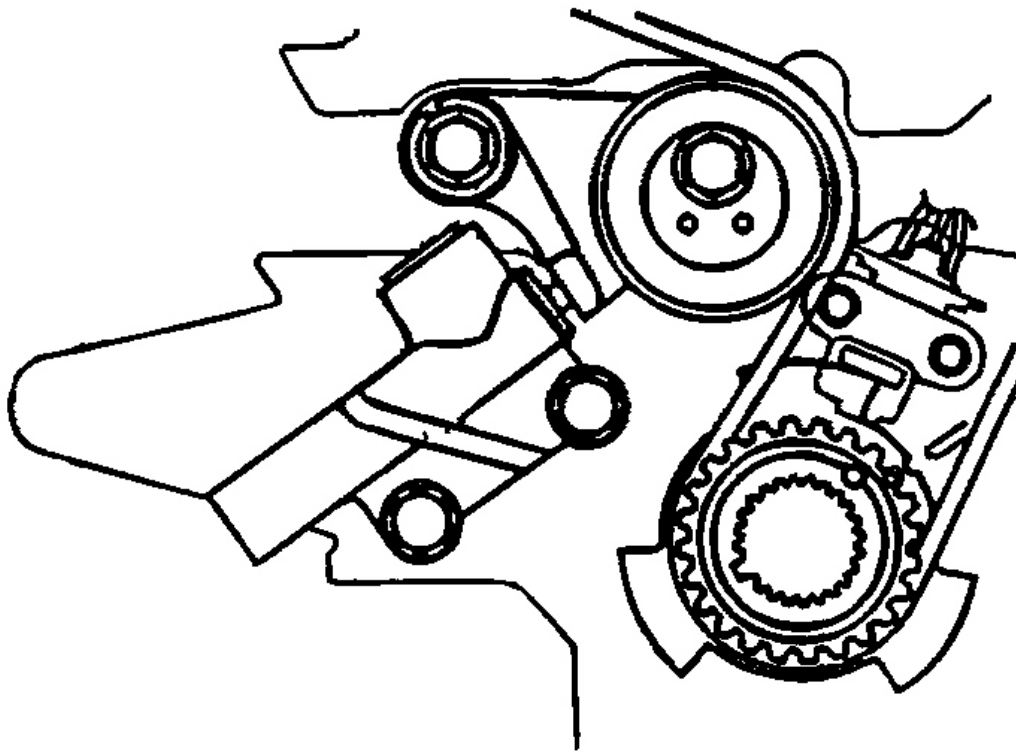

G00320686

Fig. 41: Removing The Auto Tensioner
Courtesy of KIA MOTORS AMERICA, INC.

NOTE: Rotate the crankshaft clockwise and align the timing mark to get the No. 1 cylinder's piston be in TDC position (compression stroke). At this time, the timing marks of the camshaft sprocket and cylinder head cover should coincide with each other.

7. Remove the timing belt.

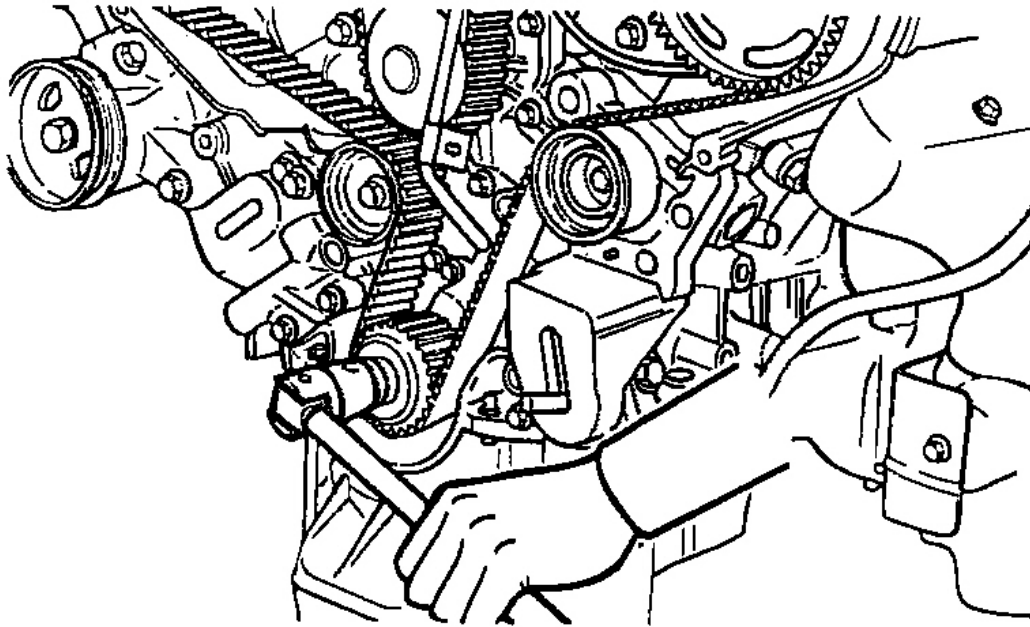

G00320687

Fig. 42: Remove The Timing Belt

Courtesy of KIA MOTORS AMERICA, INC.

NOTE: When re-using timing belt, make sure of marking the rotating direction on the belt so as to install correctly.

INSPECTION

TIMING BELT

Check the belt carefully and if any damage is found, exchange it with a new one.

1. Vulcanization of the rubber backside.

The backside is glossy and non-elastic so that, even if a finger nail is forced into it, no mark is produced.

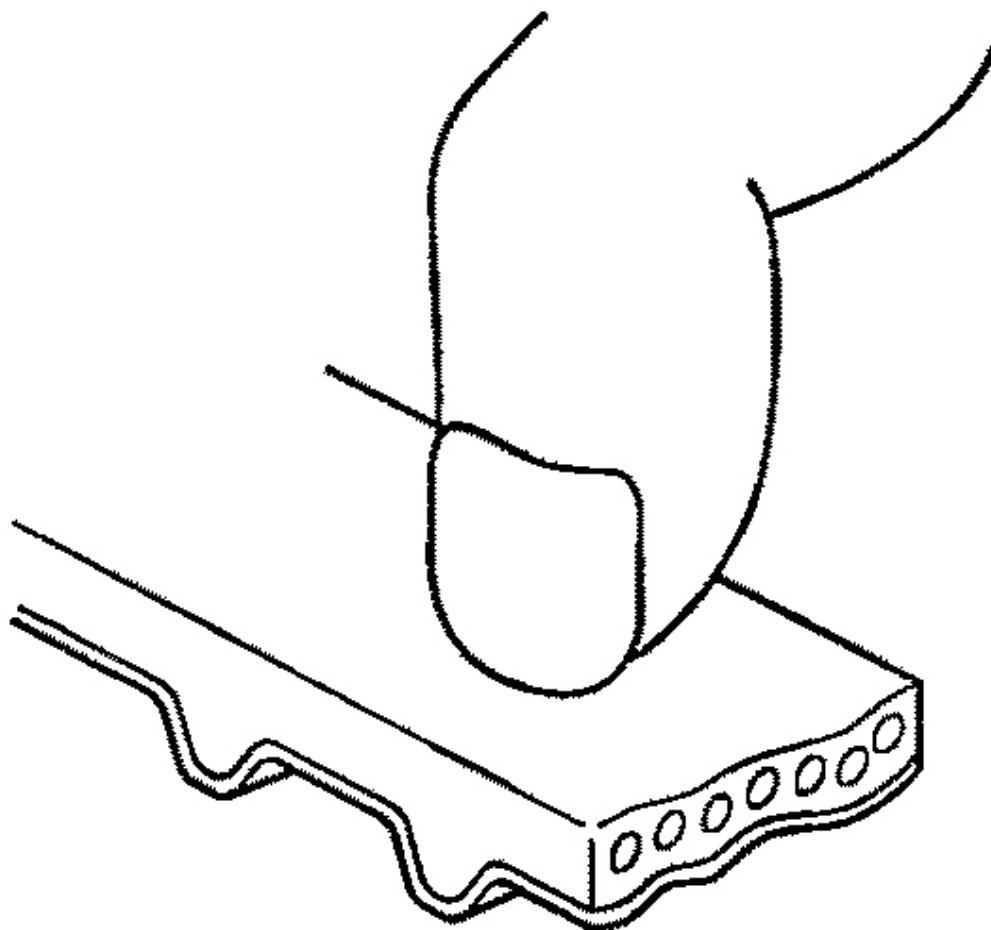

G00320688

Fig. 43: Testing Timing Belt For Vulcanization
Courtesy of KIA MOTORS AMERICA, INC.

2. Crack on the rubber belt surface.

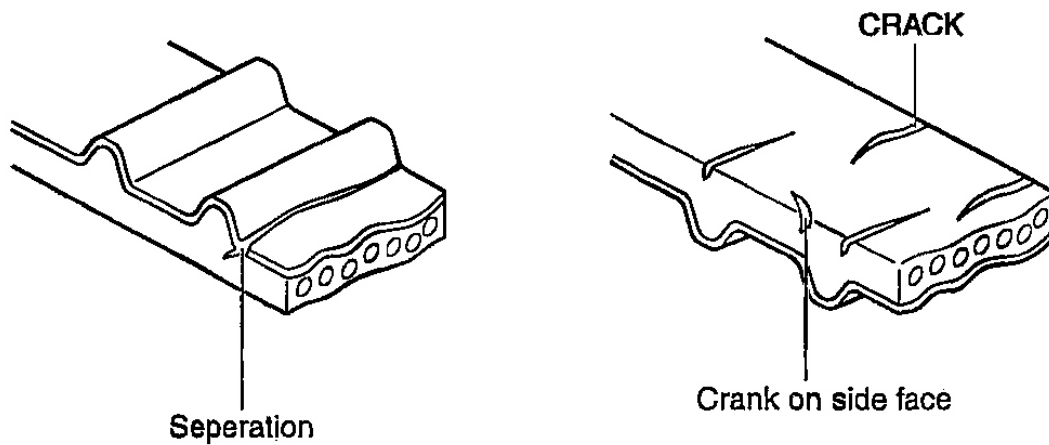

G00320689

Fig. 44: Testing Timing Belt For Cracks
Courtesy of KIA MOTORS AMERICA, INC.

3. Abnormal wearing of side face of belt.

CAUTION: Belts in good condition seem to be cut by a sharp knife.

Round shaped edge

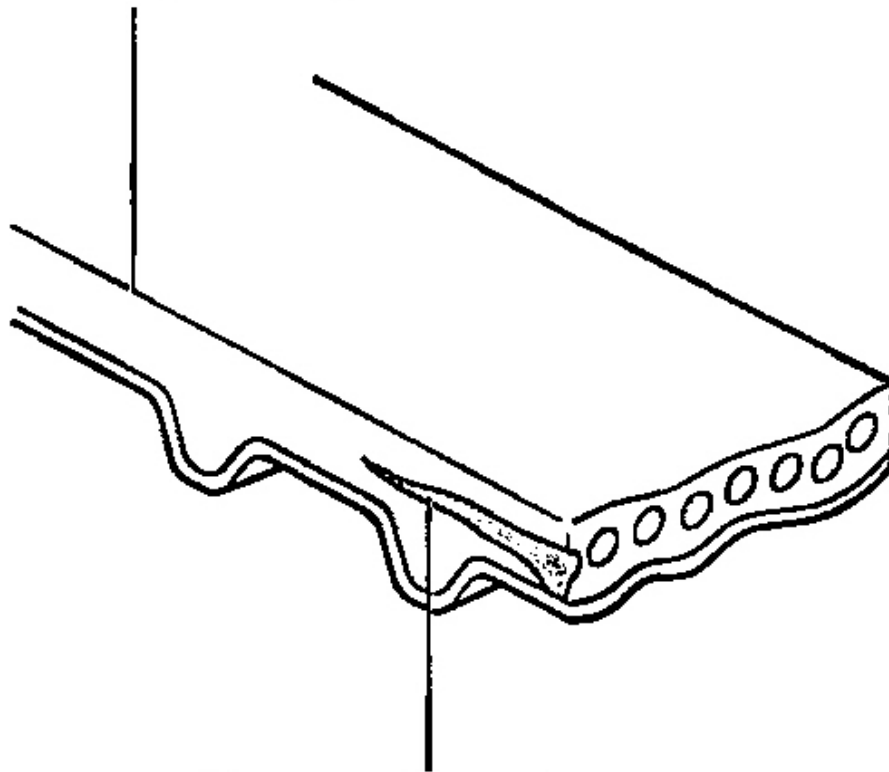

Abnormal wearing

G00320690

Fig. 45: Testing Timing Belt For Side Face Wear
Courtesy of KIA MOTORS AMERICA, INC.

4. Abnormal tooth wearing

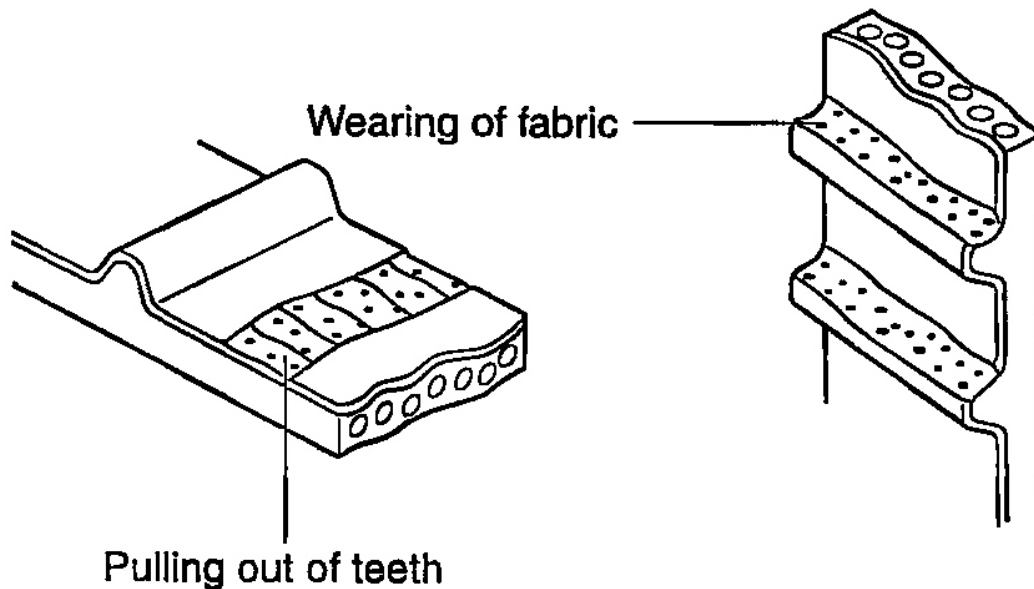

G00320691

Fig. 46: Testing Timing Belt For Abnormal Tooth Wear
 Courtesy of KIA MOTORS AMERICA, INC.

Initial stage

Wearing of side face of load exerting tooth (Fabric puff up, rubber material peel off with color changing to white and fabric become uneven and rough).

Last stage

Fabric wearing of side face of load exerting tooth occurs and rubber is exposed (Length between teeth decrease.).

5. Missing tooth.

TIMING BELT TENSIONER

If any abnormal noise or difficulty in rotating the pulley by hand is noticed, replace the timing belt tensioner and idler pulley.

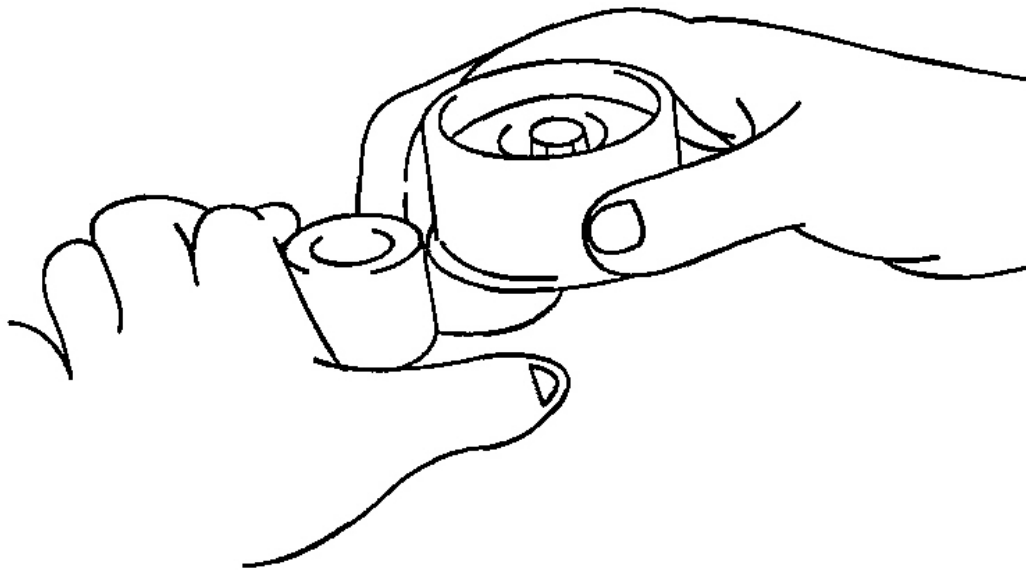

G00320692

Fig. 47: Testing Timing Belt Tensioner
Courtesy of KIA MOTORS AMERICA, INC.

INSTALLATION

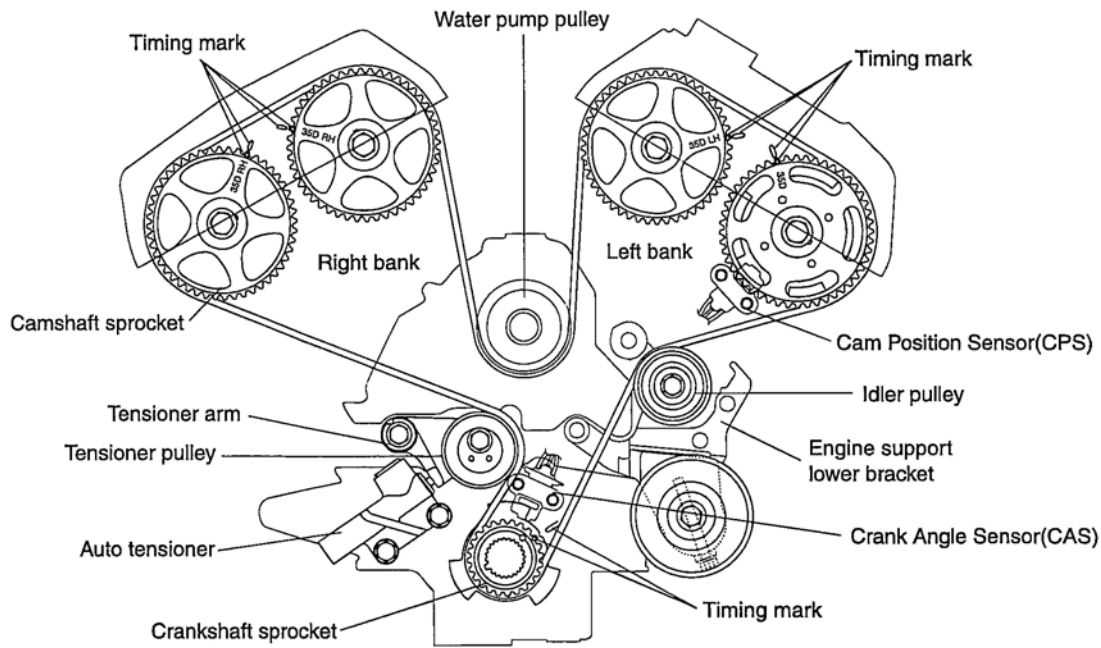

G00320683

Fig. 48: Identifying Timing Belt Positions
 Courtesy of KIA MOTORS AMERICA, INC.

TIMING BELT AND AUTO TENSIONER

1. Install the idler pulley to the engine support lower bracket.

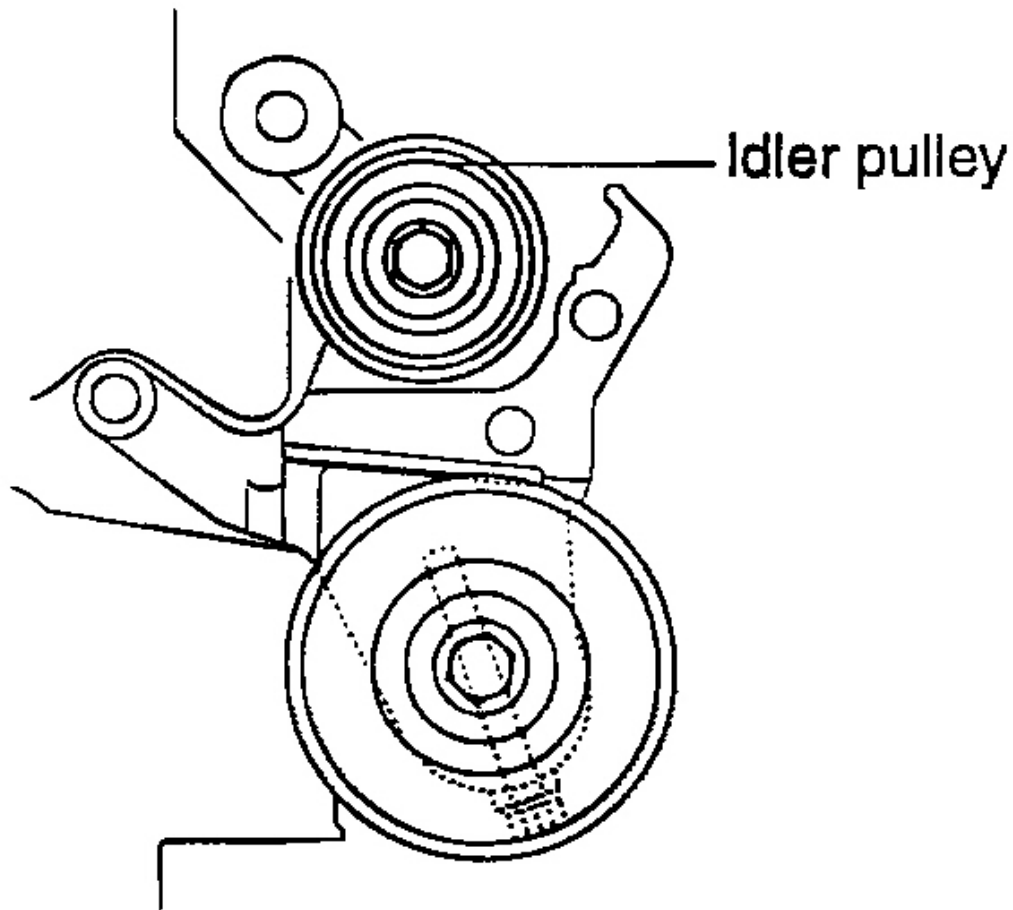

G00320693

Fig. 49: Installing The Idler Pulley To The Engine Support Lower Bracket
Courtesy of KIA MOTORS AMERICA, INC.

2. Install the tensioner arm, shaft and plain washer to the cylinder block.

Tightening torque: 35-55 N.m (350-550 kg.cm, 25.82-40.57 lb.ft)

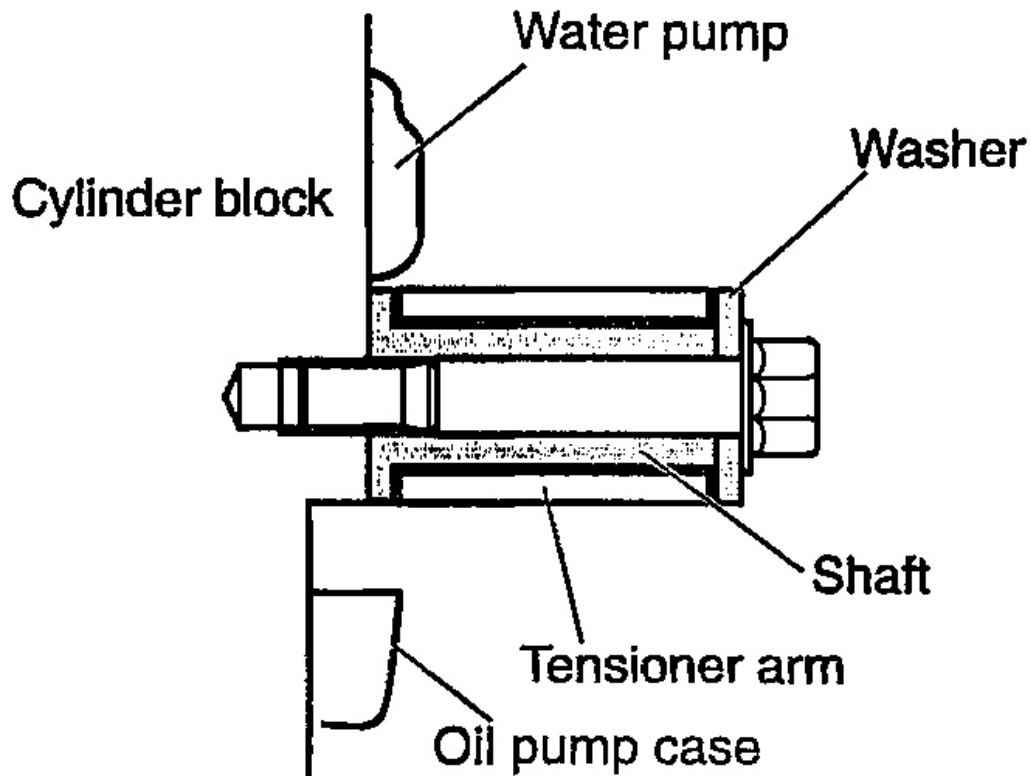

G00320694

Fig. 50: Installing The Tensioner Arm, Shaft And Plain Washer To The Cylinder Block
Courtesy of KIA MOTORS AMERICA, INC.

3. Install the crankshaft sprocket.

NOTE: Confirm if timing marks coincide with.

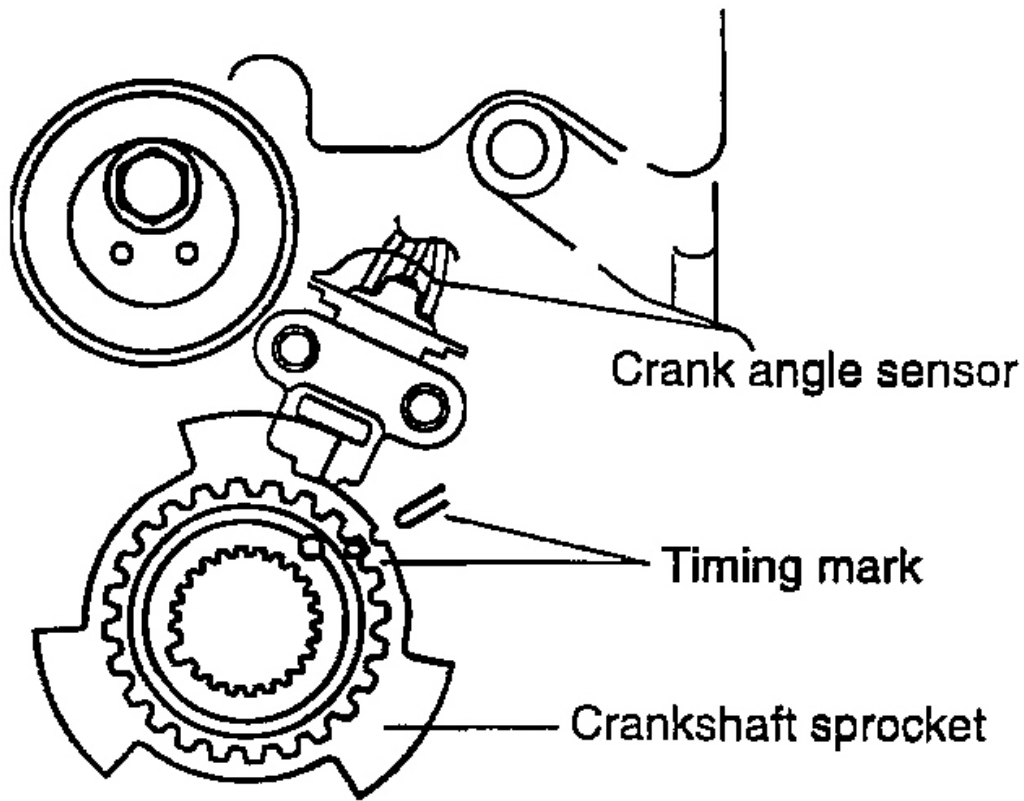

G00320695

Fig. 51: Installing The Crankshaft Sprocket
Courtesy of KIA MOTORS AMERICA, INC.

CAUTION: Align the spacer with a pin, and assemble it exerting even force not to deform the crankshaft sensing blade.

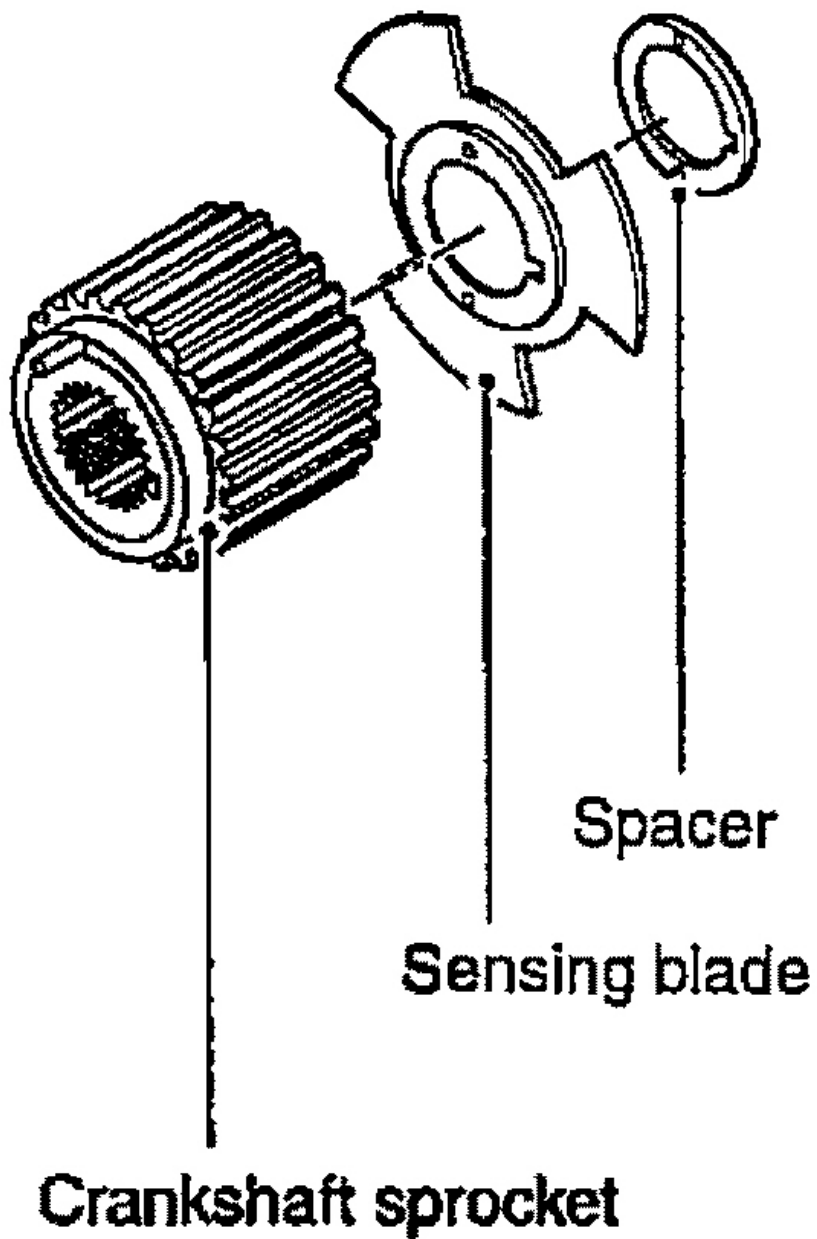

G00320696

Fig. 52: Align The Spacer & Pin
Courtesy of KIA MOTORS AMERICA, INC.

4. Install the camshaft sprocket.

Align it like initial state as shown on the picture.

CAUTION: When installing camshaft sprocket, tighten the bolt holding hexagonal part of camshaft to prevent it from turning.

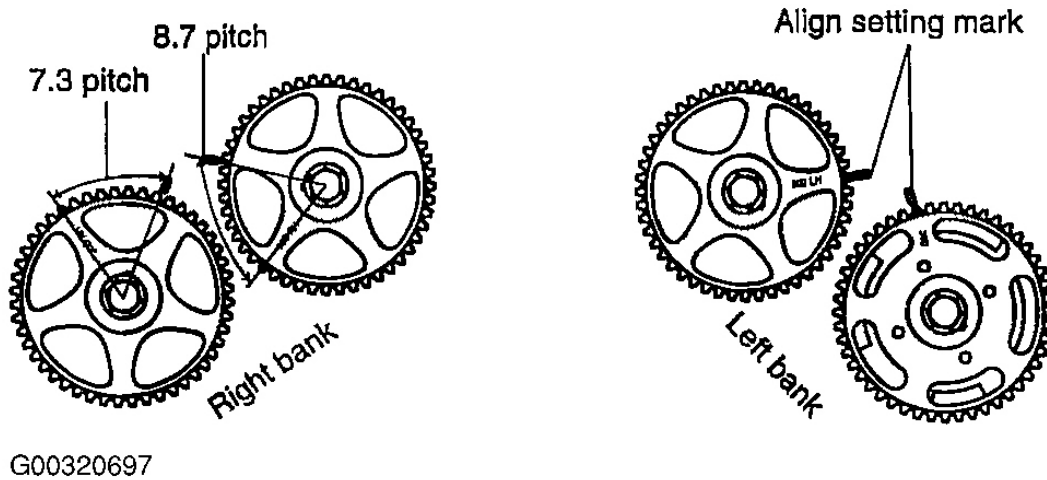
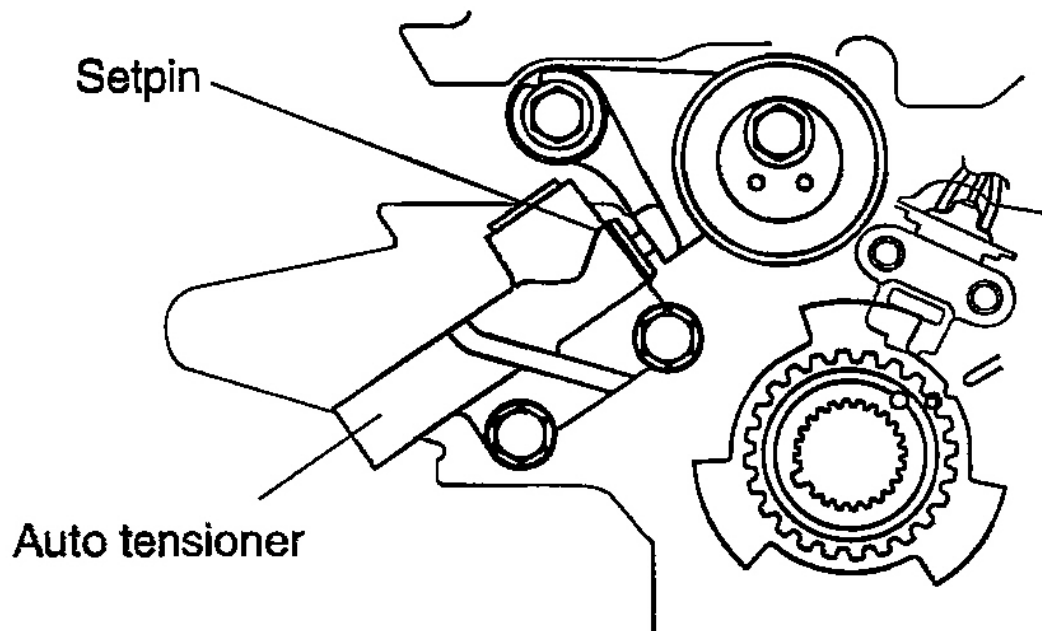

Fig. 53: Installing & Aligning Camshaft Sprockets
Courtesy of KIA MOTORS AMERICA, INC.

5. Install the auto tensioner to the oil pump case.

CAUTION: At this time the auto tensioner's set pin should be assembled completely.



G00320698

Fig. 54: Installing The Auto Tensioner To The Oil Pump Case
Courtesy of KIA MOTORS AMERICA, INC.

6. Align the timing marks of each sprocket and install the timing belt, maintaining the proper belt tension between each shaft in this order.

Crankshaft sprocket, Idler pulley, Left bank exhaust camshaft sprocket, Left bank intake camshaft sprocket, Water pump pulley, Right bank intake camshaft sprocket, Right bank exhaust camshaft sprocket and Tensioner pulley.

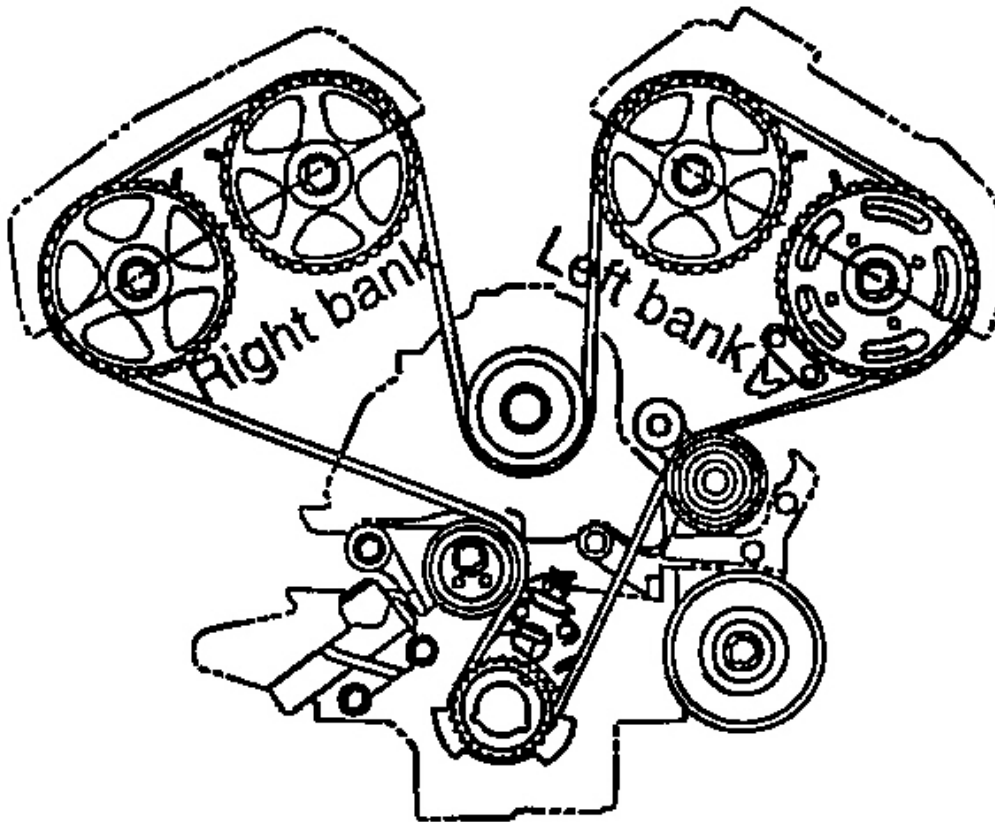

G00320699

Fig. 55: Identifying Timing Belt Routing
Courtesy of KIA MOTORS AMERICA, INC.

CAUTION:

- As a result of this, position of No. 1 cylinder comes to compression TDC.
- As each camshaft sprocket tends to rotate by itself, pay attention not to injure fingers or other bodily part. Especially be careful with the right bank.
- In case the right bank camshaft sprocket rotates excessively, be cautious not to rotate more than the initial stable position. Always align timing mark of rotating sprocket by turning it reversely. In this case, pay attention not to rotate it reversely from the initial position. (If, with one sprocket fixed at No. 1

compression TDC position, the other sprocket is rotated one revolution clockwise or counter clockwise, then the intake and exhaust valve might interfere each other.)

7. After installing the timing belt, exert the reverse-directed force to the right bank exhaust camshaft sprocket to give tension on the belt. Holding this state, recheck if each timing mark is correctly positioned.
8. With tensioner pulley slightly pushing the belt down, tighten the center bolts lightly.

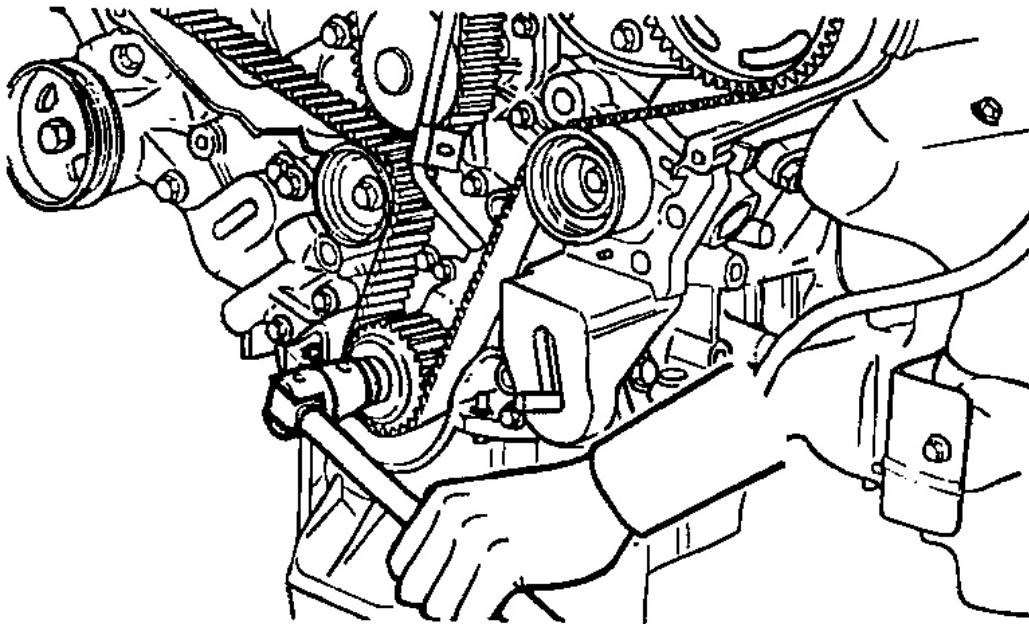

G00320700

Fig. 56: Exerting The Reverse-Directed Force To The Right Bank Exhaust Camshaft Sprocket
Courtesy of KIA MOTORS AMERICA, INC.

9. Pull out the auto tensioner set pin.

ADJUSTING TIMING BELT TENSION

1. Tension setting (While auto tensioner is not operating: And set pin being kept installed).
 1. After rotating crankshaft 1/4 revolution reversely, rotate it clockwise to position No. 1 cylinder at TDC.

Then, loosen the center bolt and give the belt 50kg-cm of tension with tensioner pulley socket (Two

pins are attached) and torque wrench. While maintaining this state, tighten the center bolt to the standard torque.

Center bolt standard torque: 43-55 N.m (430-550 kg.cm, 31.72-40.57 lb.ft)

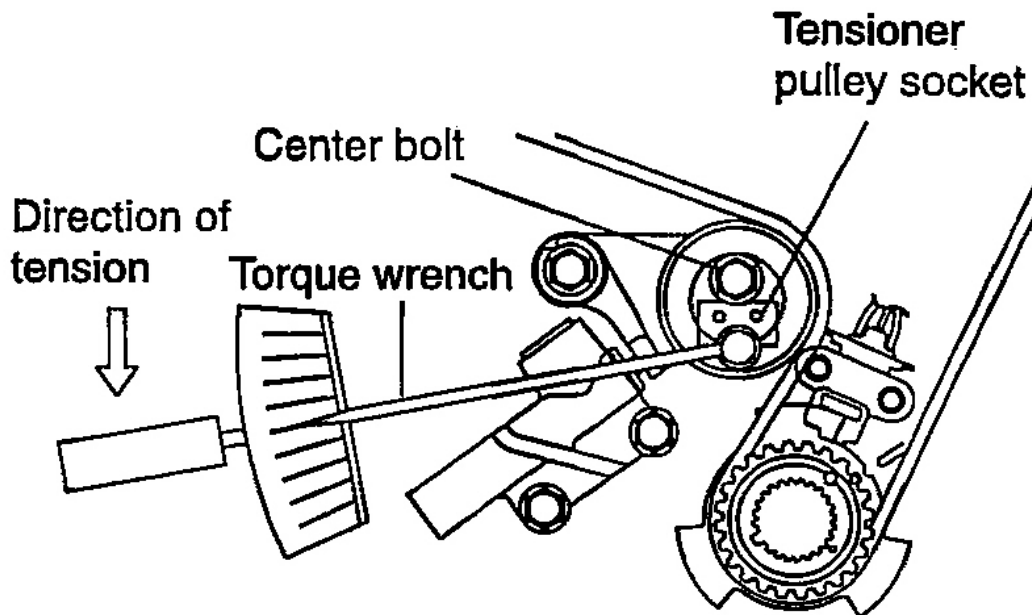

G00320701

Fig. 57: Tensioning Timing Belt
Courtesy of KIA MOTORS AMERICA, INC.

2. Pull out the auto tensioner fixing pin.

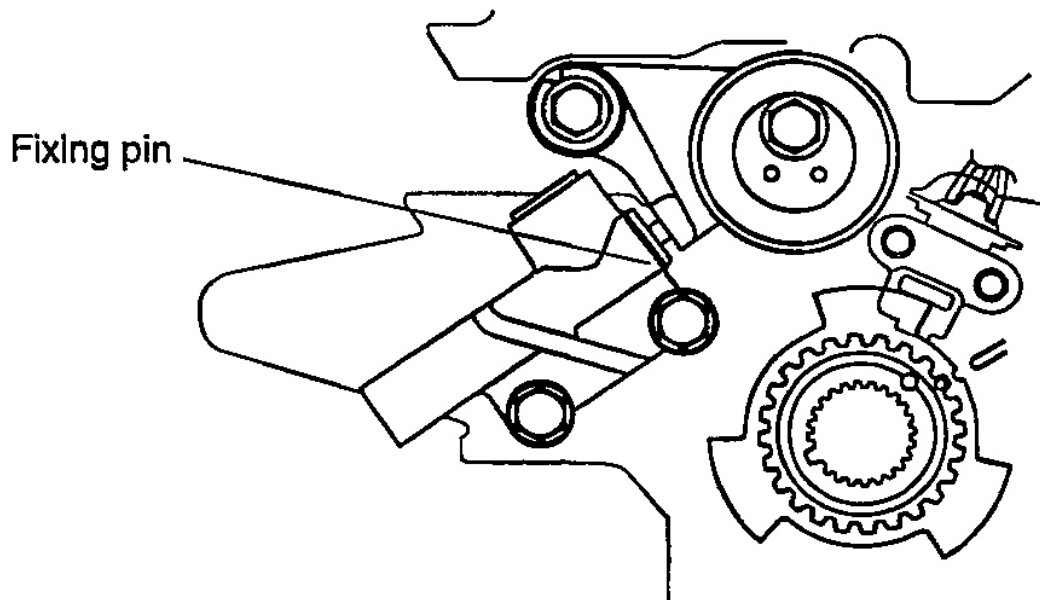

G00320702

Fig. 58: Removing Auto Tensioner Fixing Pin
Courtesy of KIA MOTORS AMERICA, INC.

2. How to check tension (While auto tensioner is operating: and fixing pin being uninstalled.)
 - a. After rotating crankshaft 2 revolutions clockwise to position No. 1 cylinder at TDC, wait for about 5 minutes, and measure the amount of protruding of the auto tensioner rod.

CAUTION: This is "leak down" time for the auto tensioner rod to protrude 1mm when tension caused by rotation of the crankshaft has changed.

- b. Check if the amount of rod protruding is in the range of 3.8~4.5mm.

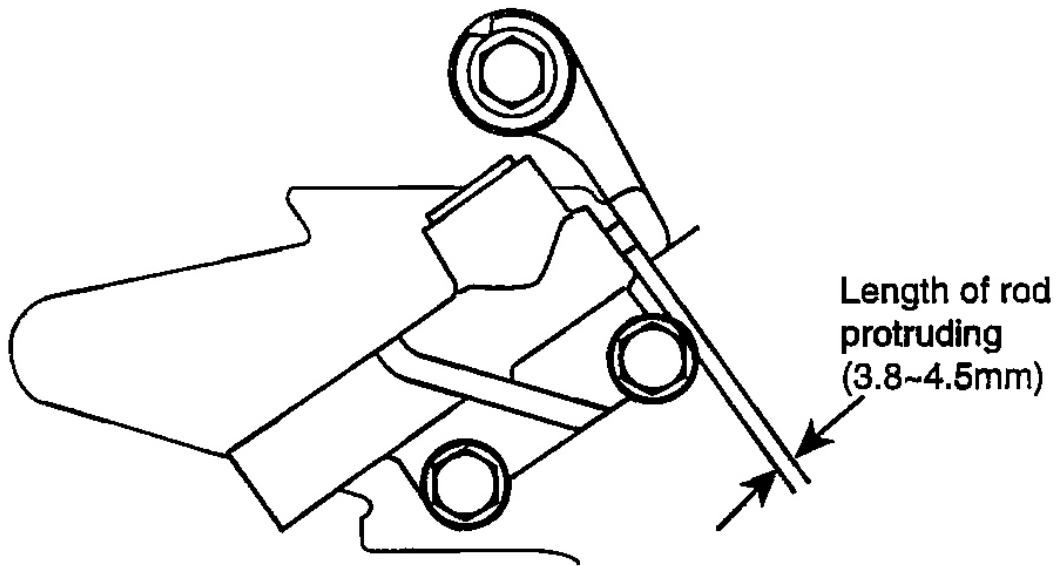

G00320703

Fig. 59: Measuring The Amount Of Rod Protruding From Auto Tensioner
Courtesy of KIA MOTORS AMERICA, INC.

- c. Recheck if each sprocket is within the specified range.

NOTE: If it is not within the specified range, repeat from TIMING BELT AND AUTO TENSIONER .

CAMSHAFT

COMPONENTS

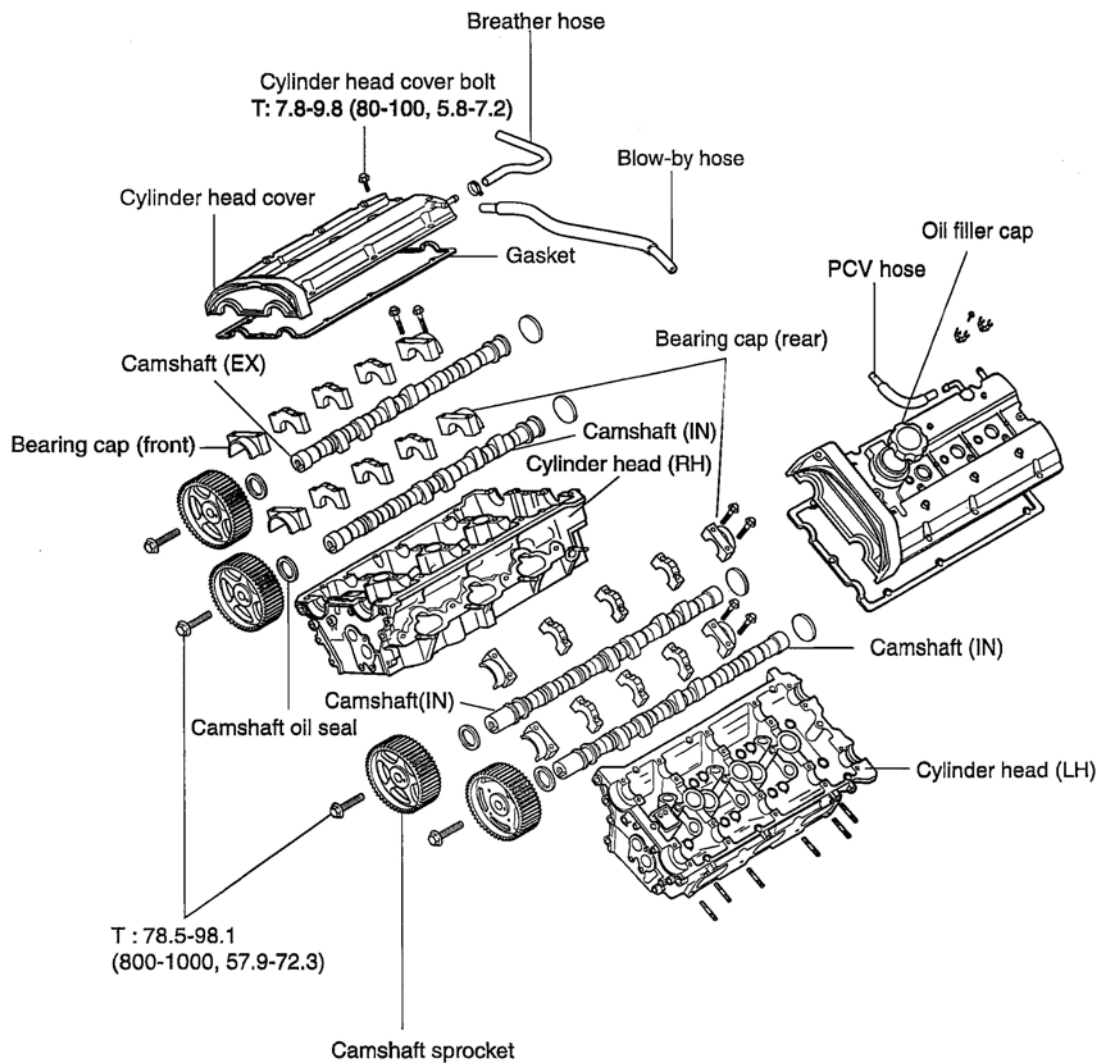

TORQUE : N·m (kg·cm, lb·ft)

G00320536

Fig. 60: Exploded View Of Camshaft Components
 Courtesy of KIA MOTORS AMERICA, INC.

REMOVAL

1. Remove the cylinder head cover.

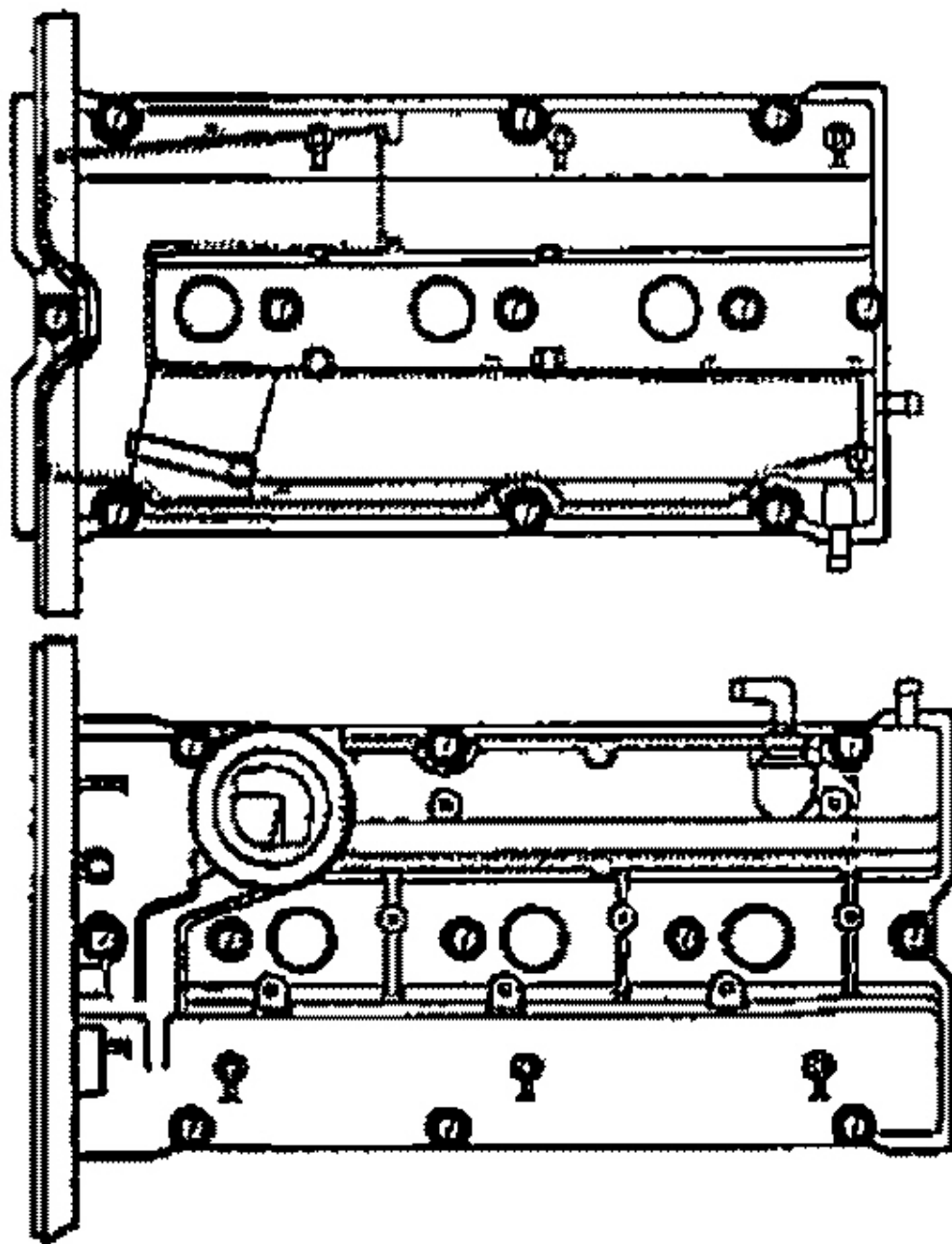

G00320537

Fig. 61: Removing Cylinder Head Cover

Courtesy of KIA MOTORS AMERICA, INC.

2. Remove the front bearing cap.

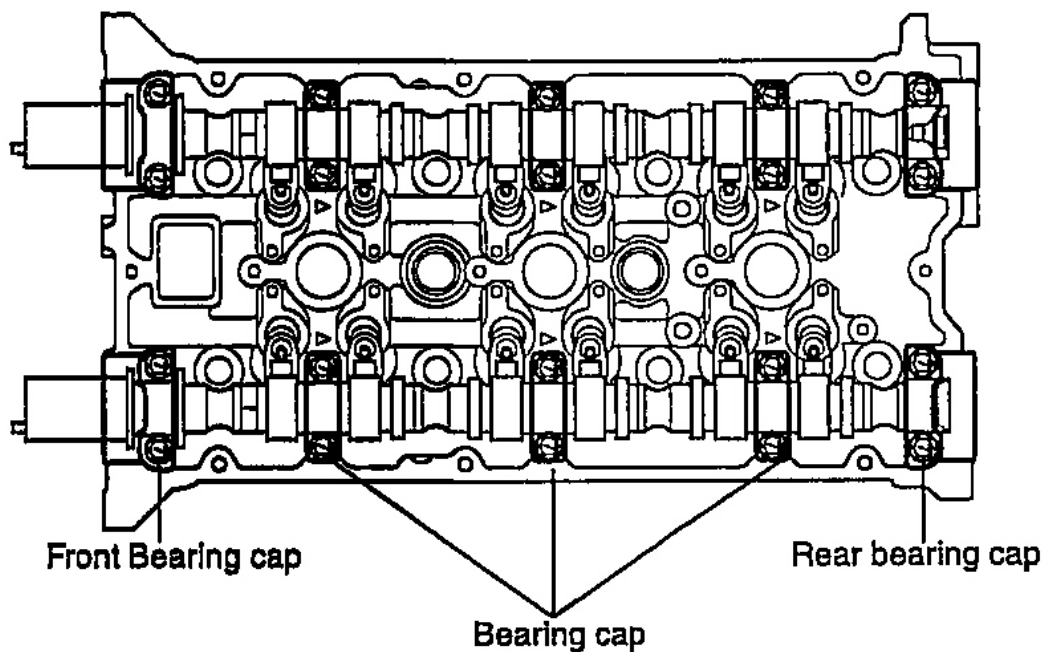

G00320538

Fig. 62: Removing Front Bearing Cover
Courtesy of KIA MOTORS AMERICA, INC.

3. Remove the rear bearing cap.
4. Remove the bearing cap.
5. Remove the camshaft oil seal.
6. Remove the camshaft.
7. Remove the rocker arm.
8. Remove the lash adjuster.

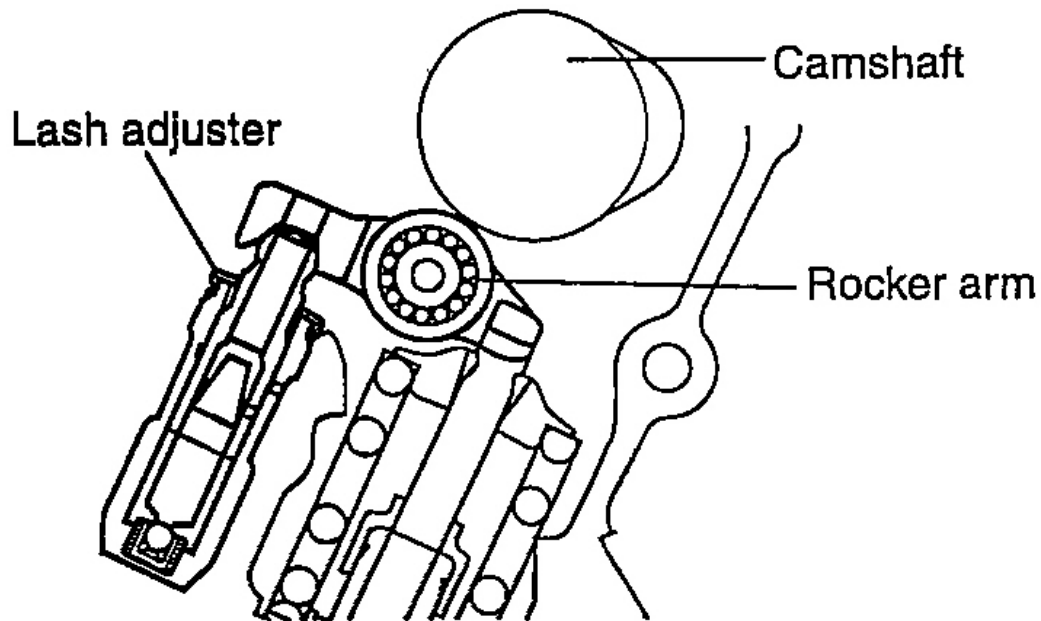

G00320539

Fig. 63: Identifying Camshaft Components
Courtesy of KIA MOTORS AMERICA, INC.

INSPECTION

CAMSHAFT

1. If there is excessive wear or damage on the camshaft journal or/and cam lobe after checking, replace it with a new one. Measure the height of cam and if the readings are beyond the specification, replace it.

Standard value:

Intake: 35.198 mm (1.385 in)

Exhaust: 34.910 mm (1.375 in)

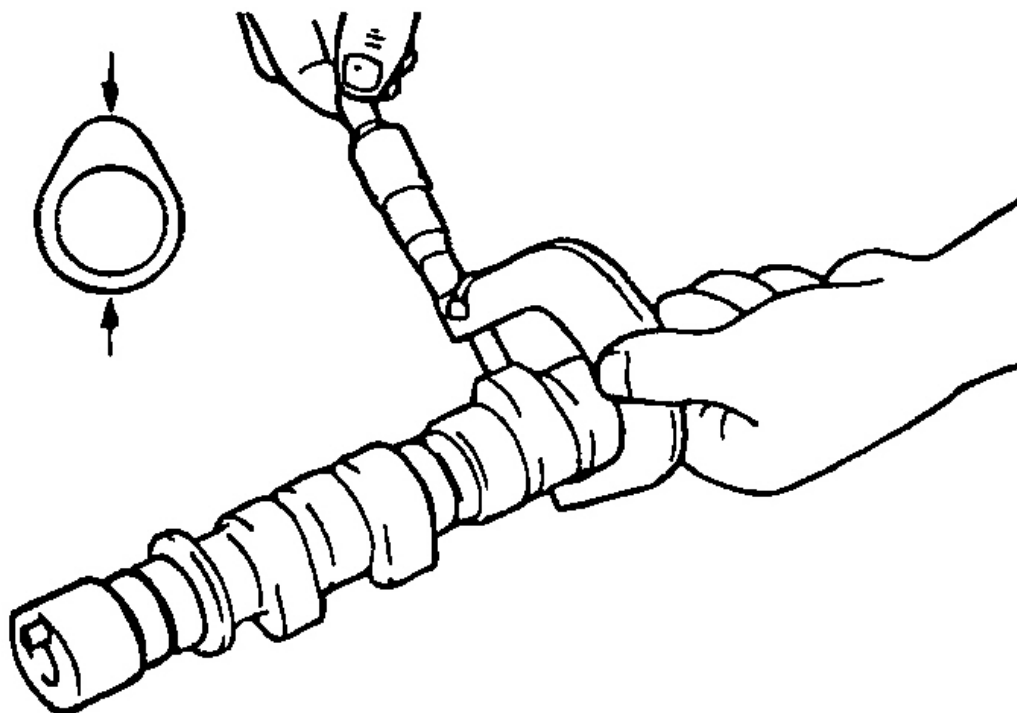

G00320540

Fig. 64: Measuring Camshaft Wear
Courtesy of KIA MOTORS AMERICA, INC.

ROCKER ARM

1. Inspect the roller visually, if any damage or crack is found, replace it.
2. Check that the roller rotates smoothly. If there is excessive clearance, replace it.

LEAK DOWN TEST OF LASH ADJUSTER

CAUTION:

- As the lash adjuster is a precise part, take care not to let any dust and foreign object enter.
- Do not disassemble the lash adjuster.
- Only light oil should be used to clean the lash adjuster

1. Immerse the lash adjuster in light oil.
2. Push out the steel ball in the lash adjuster softly using the special tool (Air bleed wire 09246-32200) and

shake the plunger upward and downward 4 or 5 times. Using the special tool (09246-32100), release air from the rocker arm installation type lash adjuster.

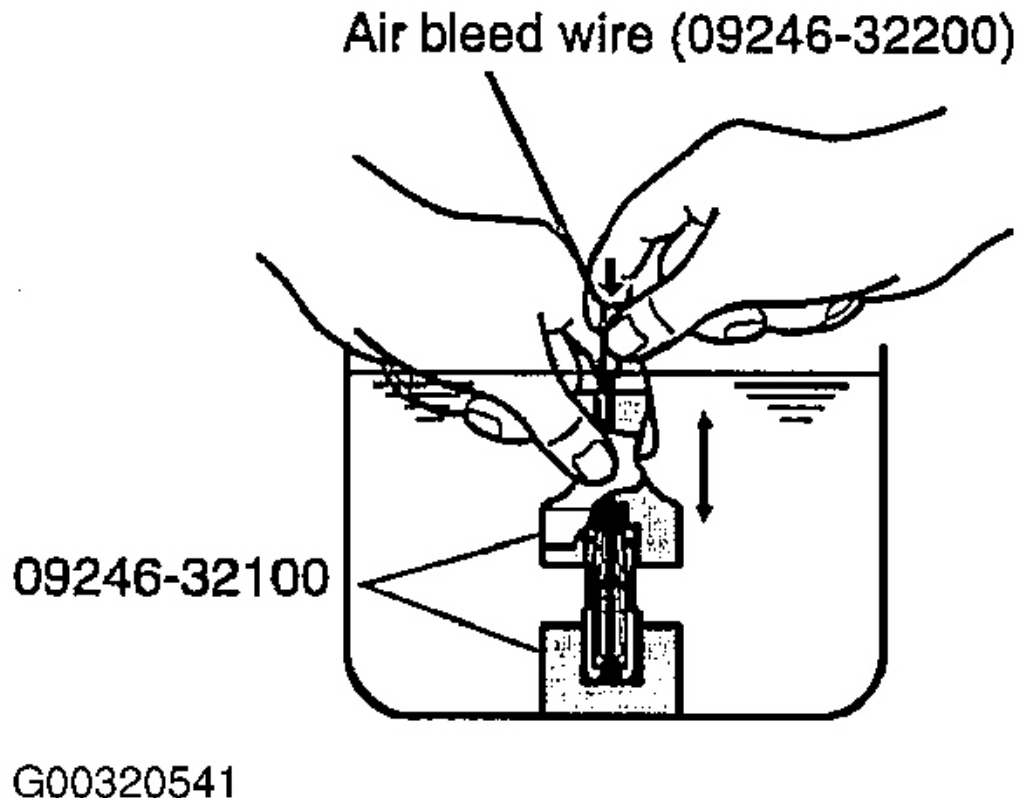

Fig. 65: Releasing Air From Lash Adjuster
Courtesy of KIA MOTORS AMERICA, INC.

CAUTION: As the ball weight is very small (just a few grams), pushing the special tool excessively can damage the lash adjuster. Push it with care and appropriate force.

3. Take away the special tool (09246-32200) and push the plunger. If it feels tight, the lash adjuster is normal. If it feels soft and easy, then release air from plunger feels and test again. If the plunger feels still soft even after releasing air, replace it.

CAUTION: After releasing air, put the lash adjuster straight up not to spill the oil over, and make sure there is no dust or foreign material on it.

4. After finishing the air release, place the lash adjuster on the special tool (09246-32300).
5. After the plunger has gone down around 0.2~0.5mm, measure the time for the plunger to go down additional 1mm. Replace it if the time is out of standard range. Standard dropping down rate: 2~16.5sec/mm (Light oil, oil temperature 20~30°C)

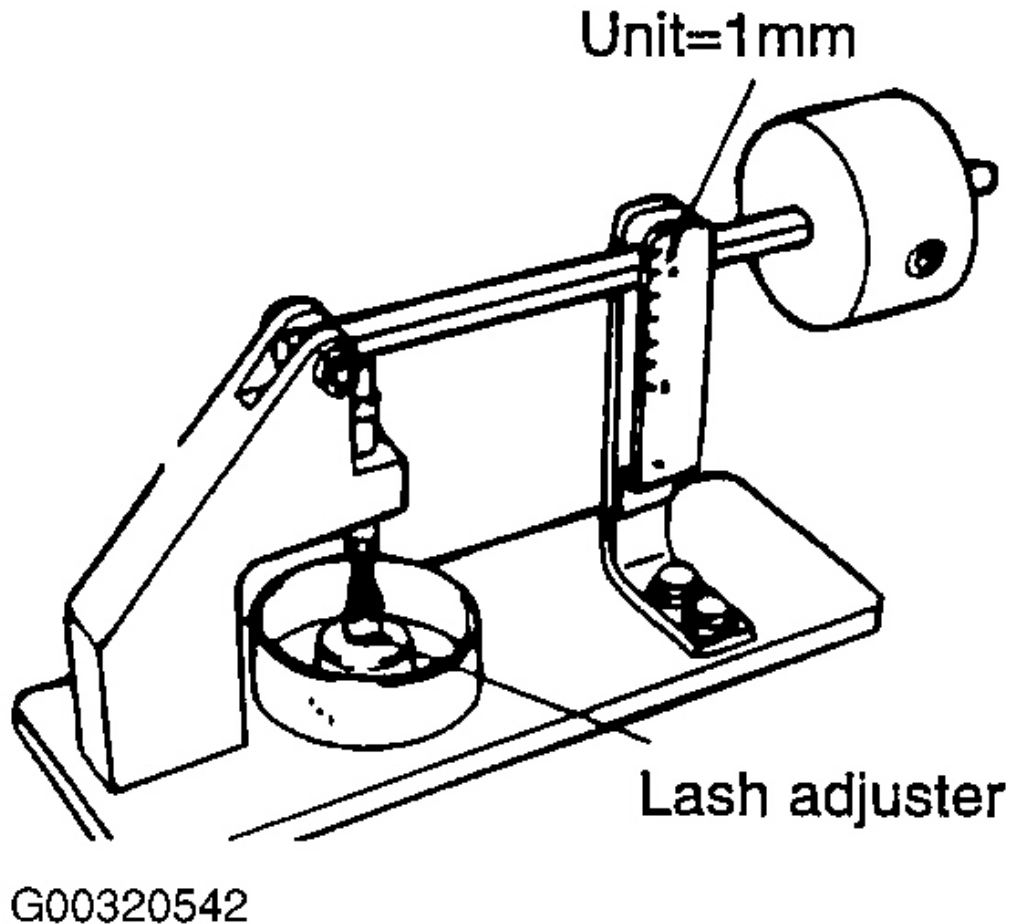

Fig. 66: Measuring Lash Adjuster Drop
Courtesy of KIA MOTORS AMERICA, INC.

ADJUSTMENT OF ROCKER ARM CLEARANCE

1. Replace the rocker arm with the one specially made for measurement.
2. After positioning the rocker arm roller on basic circle of camshaft, push down the ball lightly with special tool (09246-32200) and push down the rocker arm by hand. Maintaining that state, measure the thickness

by inserting a thickness gauge between the camshaft and rocker arm.

Clearance between camshaft (Basic circle) and rocker arm (roller): 0.7 ± 0.25 mm (0.0276 ± 0.0098 in)

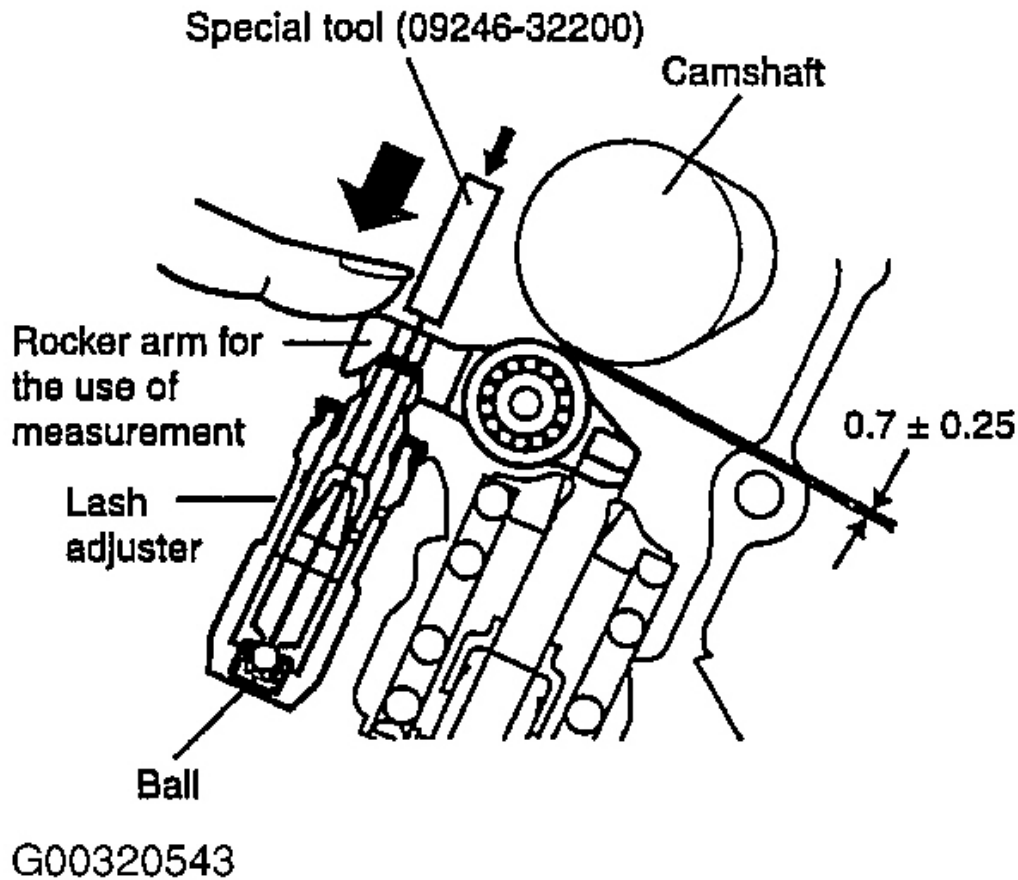

Fig. 67: Measuring Rocker Arm Clearance
Courtesy of KIA MOTORS AMERICA, INC.

CAUTION: As the ball weight is very small (just a few grams), pushing the special tool excessively can damage the lash adjuster. Push it with care and appropriate force.

INSTALLATION

CAMSHAFT AND BEARING CAP

1. Rotate the crankshaft and No. 1 cylinder is in TDC. (Compression stroke)
2. Check the position of the rocker arm whether it is exactly installed on the lash adjuster and valve or not.
3. Install the camshaft dowel pin as shown.

Cylinder head(RH)

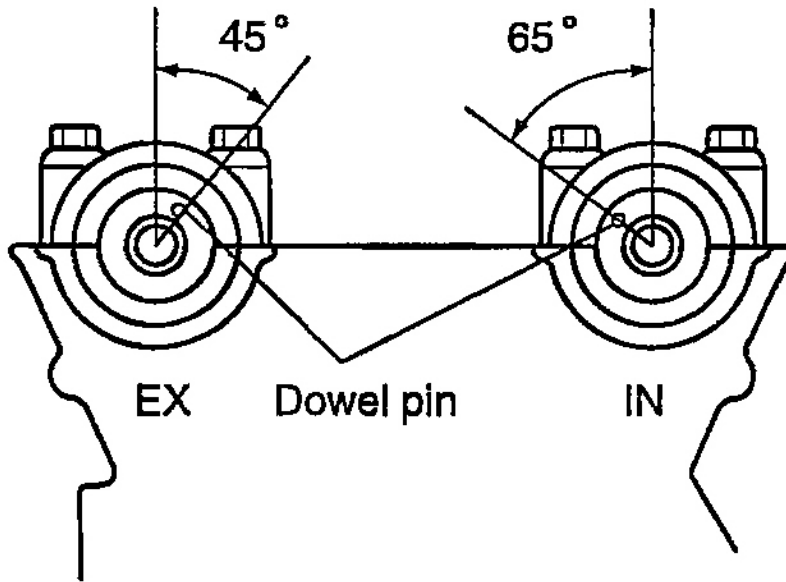

Cylinder head(LH)

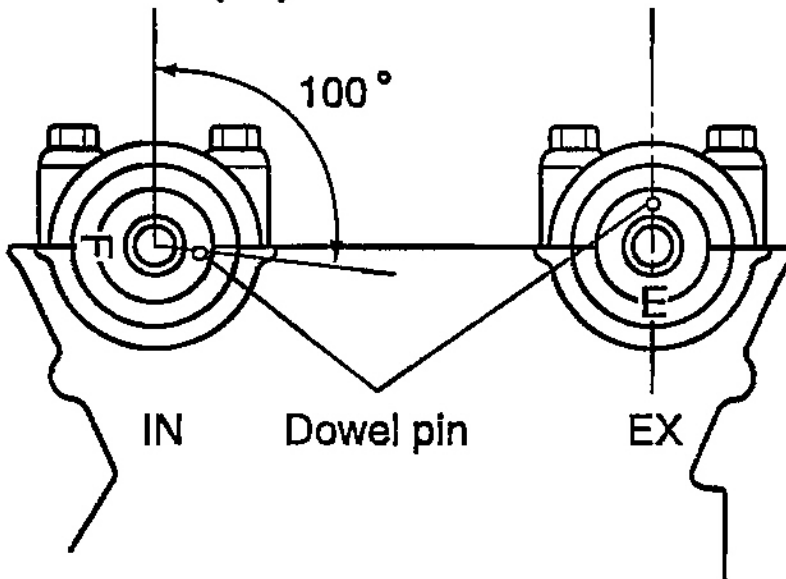

Fig. 68: Installing Camshaft Dowel Pin
 Courtesy of KIA MOTORS AMERICA, INC.

- The left and right banks of the camshafts are different and you should be careful not to confuse them. For camshaft identification, see identification signal below.

CAMSHAFT IDENTIFICATION SIGNAL

Application	Identification Signal
Left Bank	
Intake	F
Exhaust	E
Right Bank	
Intake	G
Exhaust	H

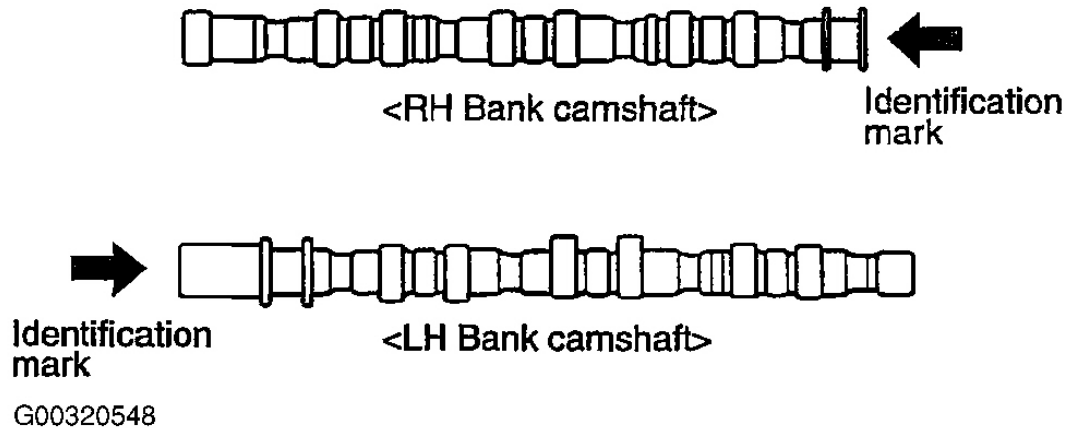

Fig. 69: Illustrating Camshaft Inscribing Position
 Courtesy of KIA MOTORS AMERICA, INC.

- Confirm the identification mark and the number. Bearing caps of No. 3, No. 4, and No. 5 have the front mark and arrange the front mark upon the cylinder head while installing the bearing caps.

Identification mark Intake (IN) Exhaust(Ex)	I E
---------------------------------------------------	--------

G00320549

Fig. 70: Illustrating Bearing Caps Identification Mark Chart
Courtesy of KIA MOTORS AMERICA, INC.

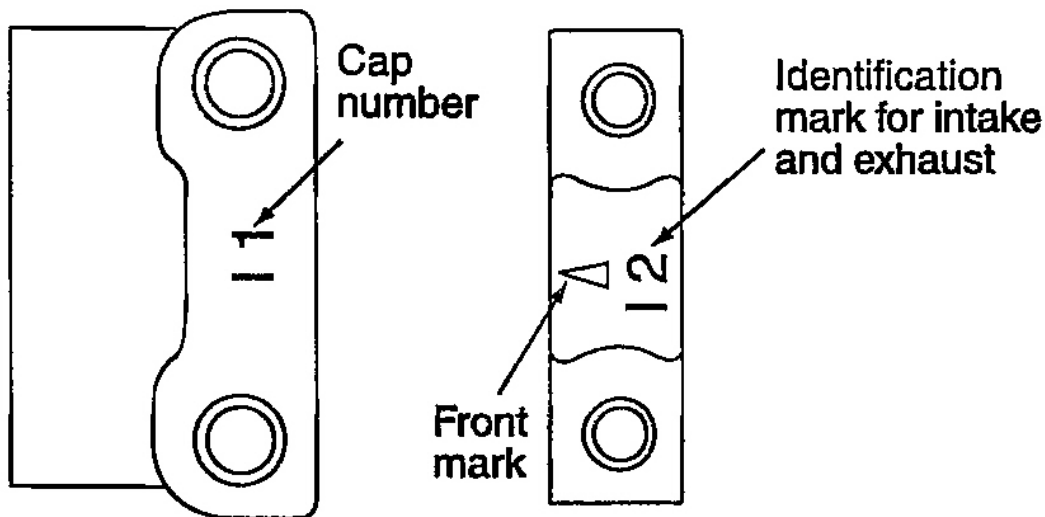

G00320550

Fig. 71: Illustrating Bearing Caps Identification Marks
Courtesy of KIA MOTORS AMERICA, INC.

- Tighten the bearing cap in two or three steps. Tighten it to the standard torque at the last stage.

Bearing cap standard torque:

16 pieces at the both ends: 21-26 N.m (210-260 kg-cm., 15-19 ft.lbs.)

24 pieces in the middle: 10-12 N.m (100-120 kg.cm, 7.38-8.85 ft.lbs.)

<Left bank>

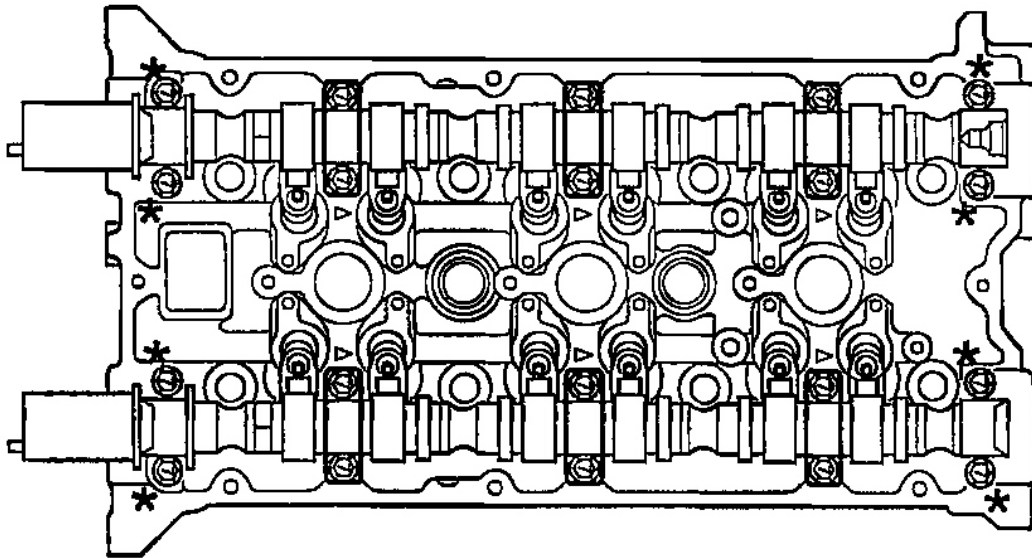

G00320551

Fig. 72: Locating Bearing Cap Positions
Courtesy of KIA MOTORS AMERICA, INC.

CYLINDER HEAD ASSEMBLY

COMPONENTS

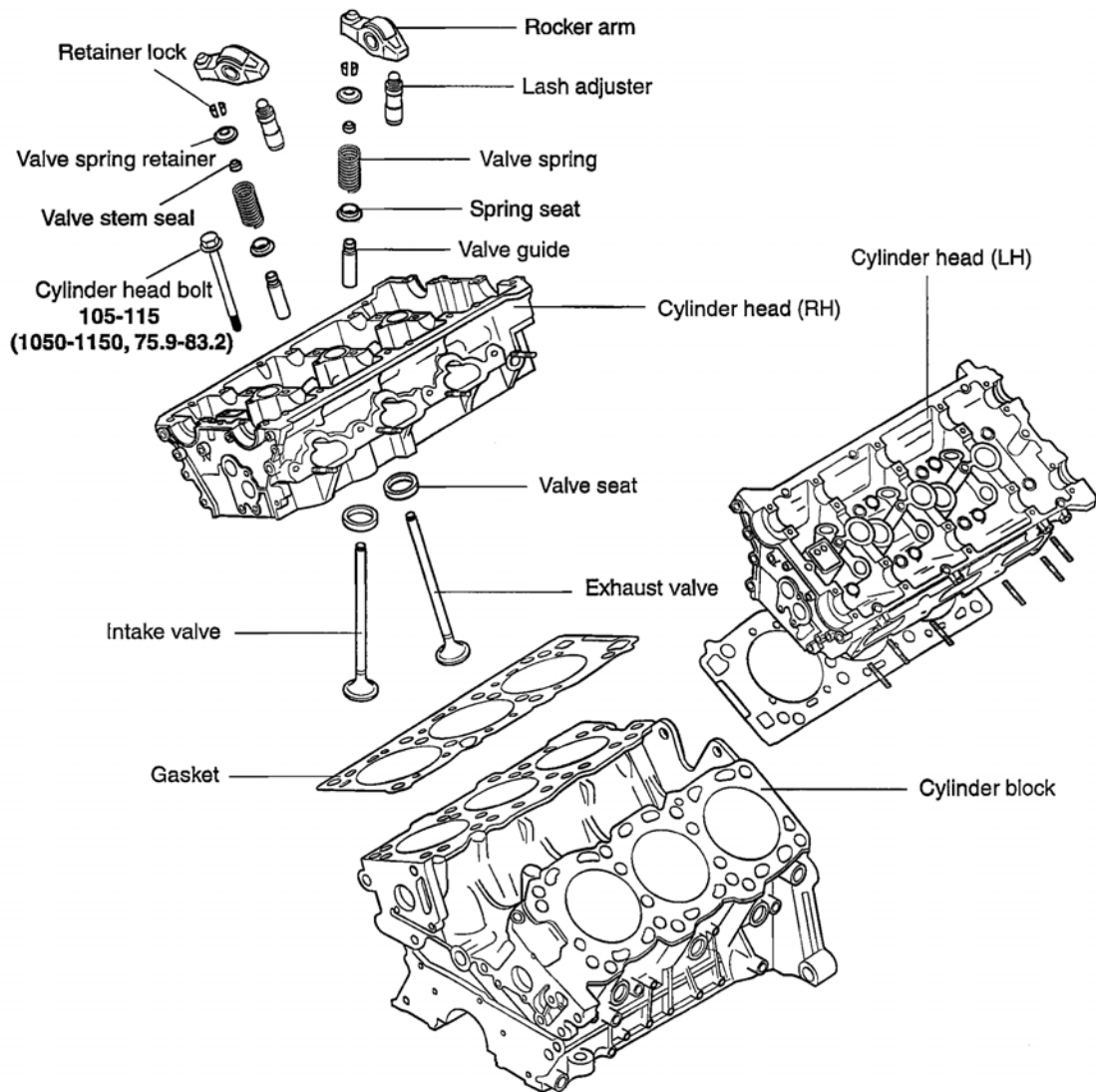

TORQUE : N·m (kg·cm, lb·ft)

G00320661

Fig. 73: Exploded View Of Cylinder Head Assemblies
 Courtesy of KIA MOTORS AMERICA, INC.

DISASSEMBLY

Arrange removal parts according to cylinder numbers, intake and exhaust valves.

REMOVING CYLINDER HEAD BOLT

Remove the cylinder head bolts using the hexagonal wrench.

REMOVING RETAINING LOCK

1. Compress the valve spring using Service Tool (09222-28000, 09222-28100).

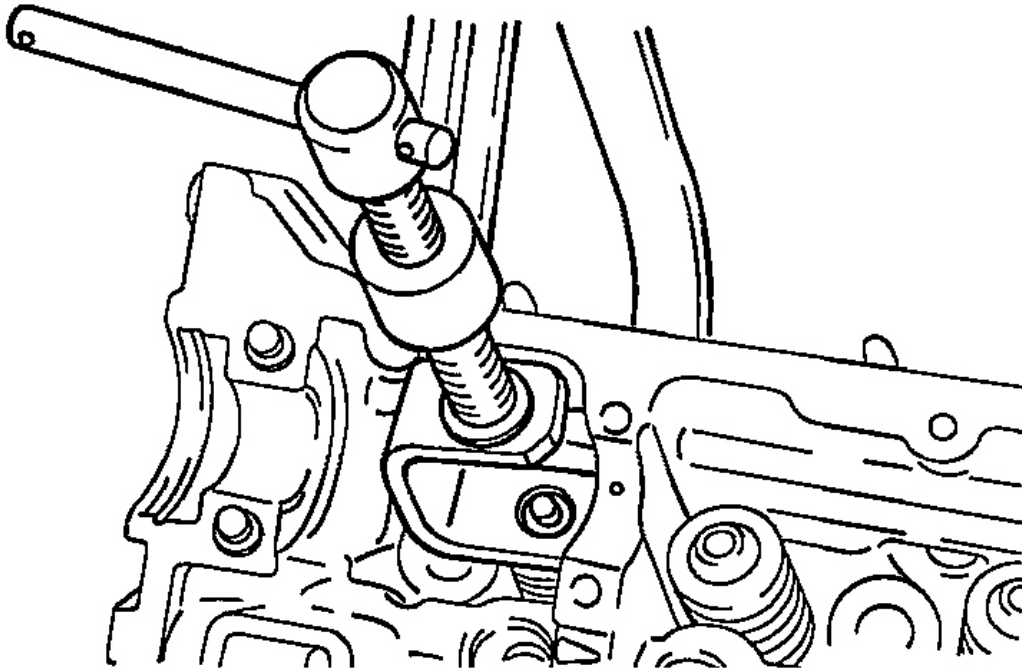

G00320662

Fig. 74: Compressing Valve Springs
Courtesy of KIA MOTORS AMERICA, INC.

2. Remove the retainer lock.

REMOVING VALVE STEM SEAL

Do not reuse the valve stem seal.

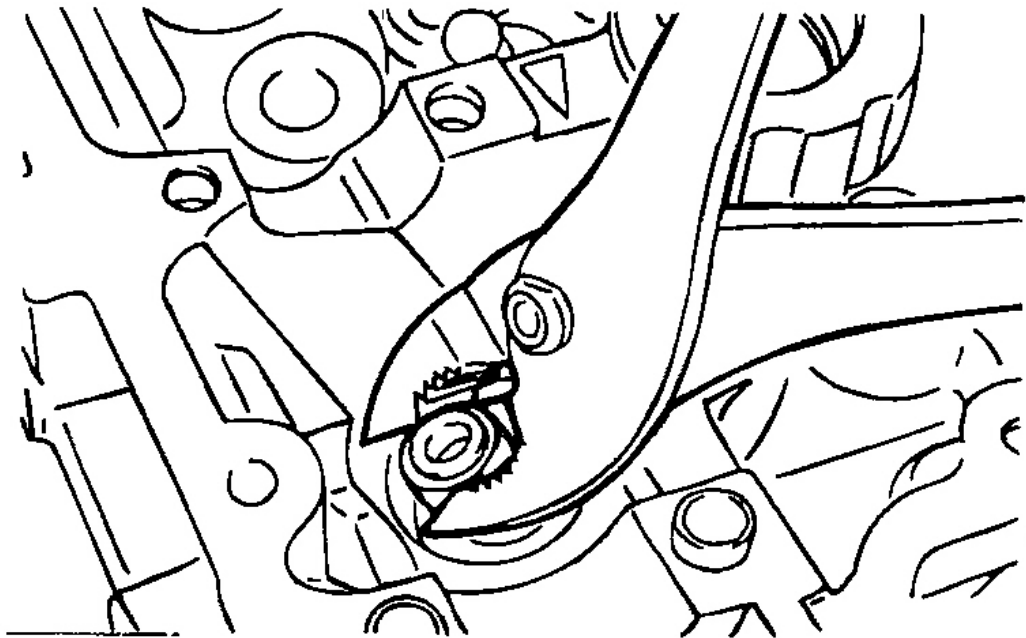

G00320663

Fig. 75: Removing Valve Stem Seals
Courtesy of KIA MOTORS AMERICA, INC.

INSPECTION & SERVICING

CYLINDER HEAD (Bare)

1. Remove scale, sealing compound and carbon deposits completely. After cleaning oil passages, apply compressed air to make certain that the passages are not clogged.
2. Visually check the cylinder head for cracks, damage or water leakage.
3. Check the cylinder head gasket surface for flatness with a straight edge and feeler as shown in illustration

Flatness of cylinder head gasket:

Standard dimension: 0.03mm (0.0012 in) or lower

Service limit: 0.2mm (0.0079 in)

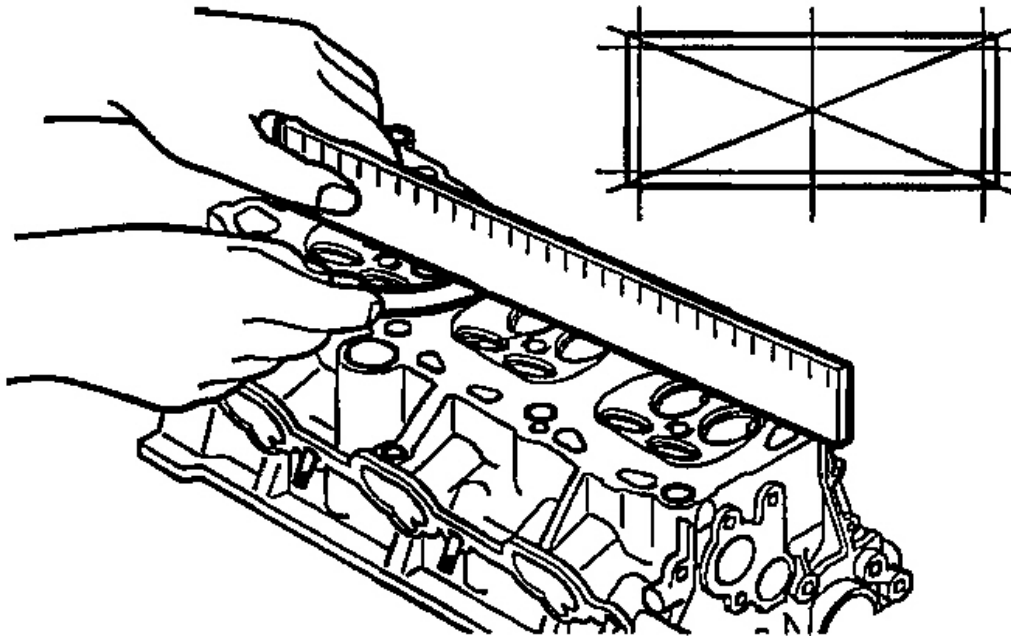

G00320664

Fig. 76: Measuring Cylinder Head Flatness
Courtesy of KIA MOTORS AMERICA, INC.

VALVES

1. Clean the valve with wire brush.

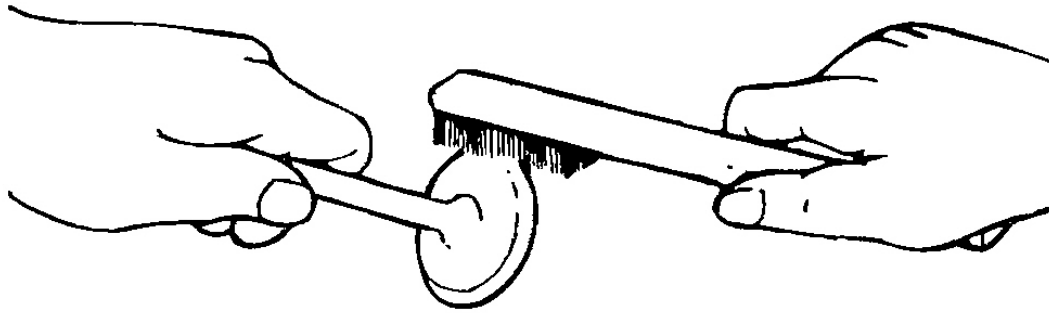

G00320667

Fig. 77: Illustrating Cleaning Valves
 Courtesy of KIA MOTORS AMERICA, INC.

2. Inspect wear and damage of each valve. Check for bending at the valve head and stem if there is wear, replace the valve. If margin is smaller than service standard, replace the valve.

VALVE MEASUREMENTS

Application	Margin Standard In. (mm)	Margin Limit In. (mm)
Intake	0.039 (1.0)	0.02 (0.5)
Exhaust	0.059 (1.5)	0.039 (1.0)

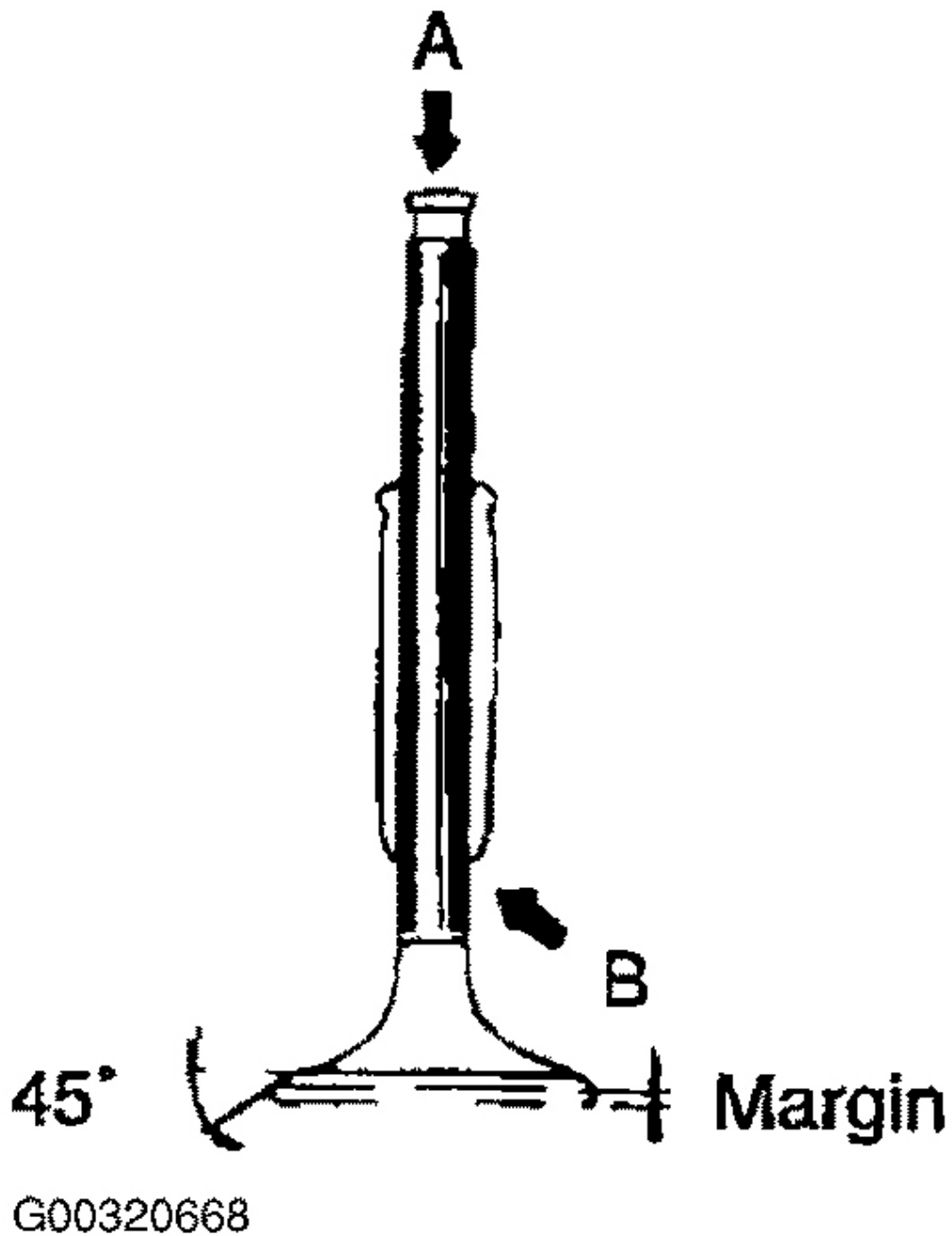

G00320668

Fig. 78: Illustrating Valve Margin
Courtesy of KIA MOTORS AMERICA, INC.

VALVE SPRINGS

1. Check free height of each valve spring and replace if necessary.
2. Using a square, test squareness of each valve spring. If spring is excessively out of square, replace it.

VALVE SPRING HEIGHT MEASUREMENTS

Application	Margin Standard In. (mm)	Margin Limit In. (mm)
Height With No Load	1.8268 (46.4)	1.7874 (45.4)

VALVE SPRING RECTANGULARITY MEASUREMENTS

Application	Standard	Margin Limit
Deviation Of Rectangularity	Less Than 2 Degrees	4 Degrees

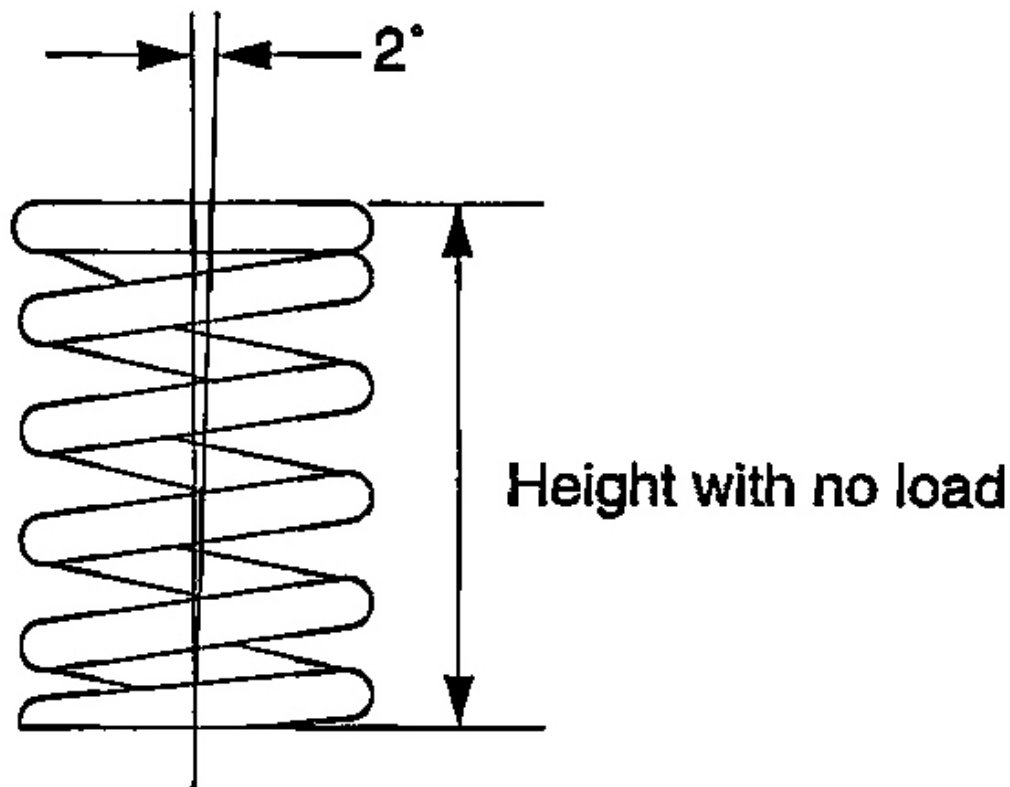

G00320669

Fig. 79: Measuring Valve Spring Values

Courtesy of KIA MOTORS AMERICA, INC.

VALVE GUIDE

Check the valve stem-to-guide clearance. If the clearance exceeds the service limit, replace the valve guide with a new oversize guide.

VALVE GUIDE MEASUREMENTS

Application	Margin Standard In. (mm)	Service Limit In. (mm)
Intake	0.0009-0.00020 (.02-.05)	0.0039 (0.1)
Exhaust	0.002-0.0033 (0.05-0.085)	0.0059 (0.15)

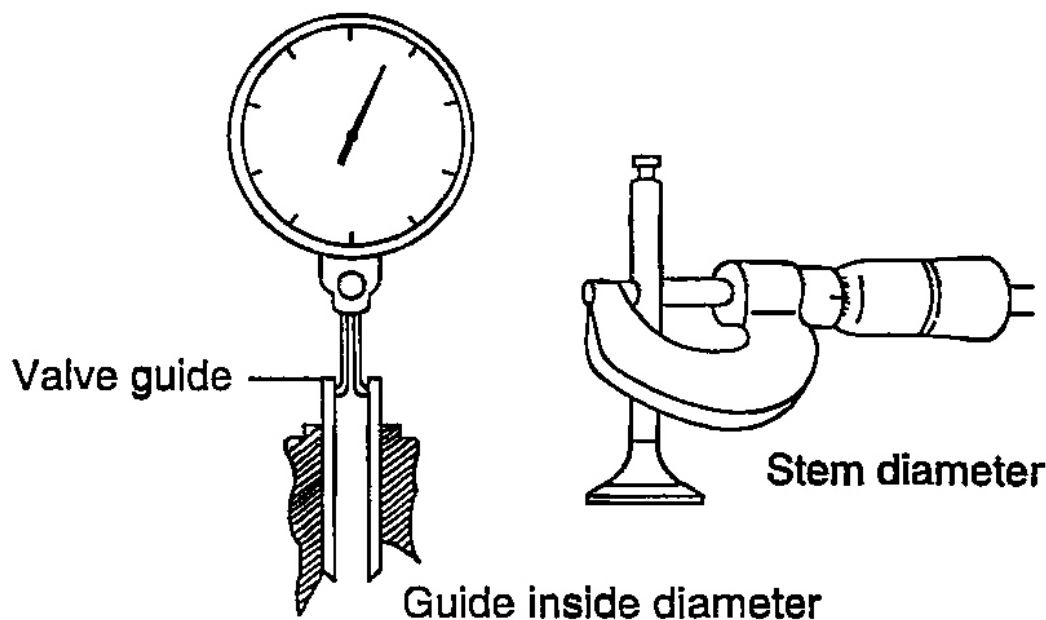

G00320670

Fig. 80: Measuring Valve Guide Clearance
Courtesy of KIA MOTORS AMERICA, INC.

VALVE SEAT INSERT

Inspect for any trace of overheating and the contact state of valve face. If necessary, repair or replace it. When repairing, inspect for wear in the valve guide. If the guide is worn, replace it and adjust the seat ring. Adjust the valve seat with grinder or cutter making valve seat contact width from the center of valve face to within the specified value. When adjusting the exhaust valve seat, use the valve seat cutter or pilot. After adjustment, lapping process can be made by using applying compound on the valve and valve seat.

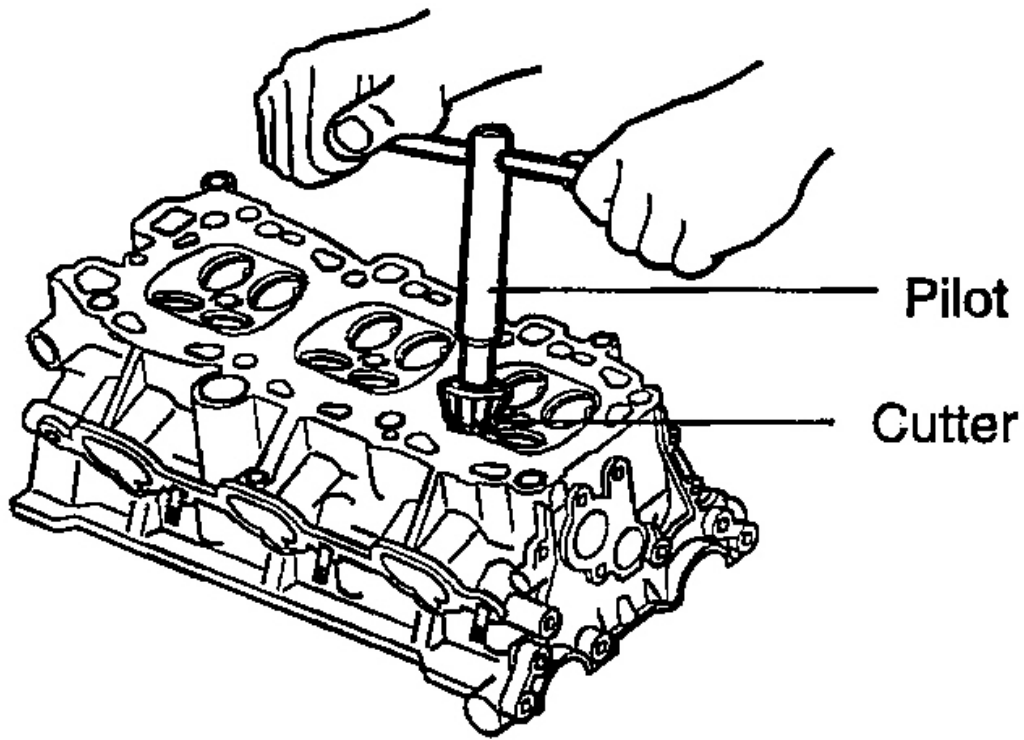

G00320671

Fig. 81: Grinding Valve Seat
Courtesy of KIA MOTORS AMERICA, INC.

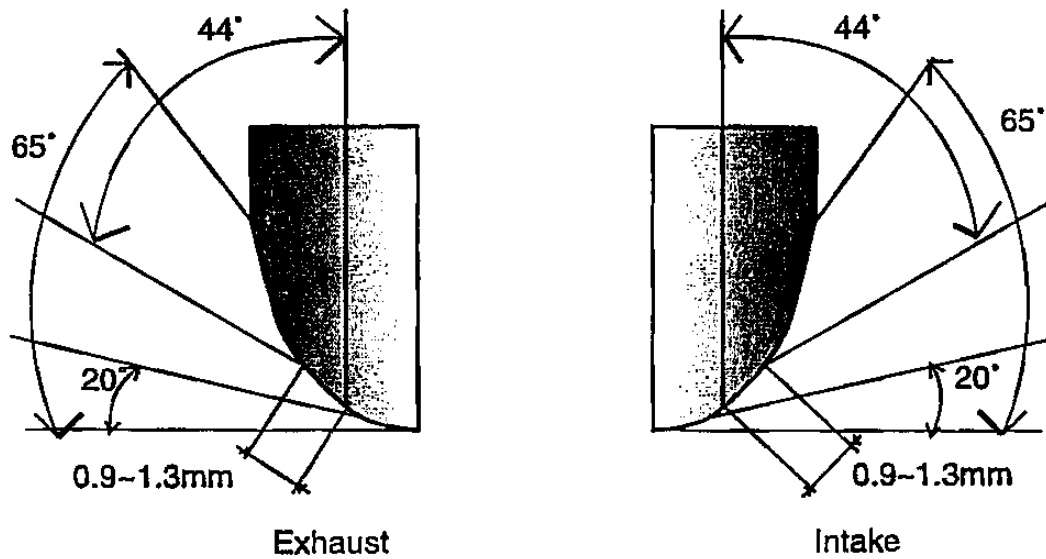

G00320672

Fig. 82: Valve Seat Angle Chart
 Courtesy of KIA MOTORS AMERICA, INC.

VALVE SEAT REPLACEMENT PROCEDURE

1. If the valve seat insert is excessively worn, cut out the insert wall using valve seat cover at normal temperature. See figure "A" in figure 83.

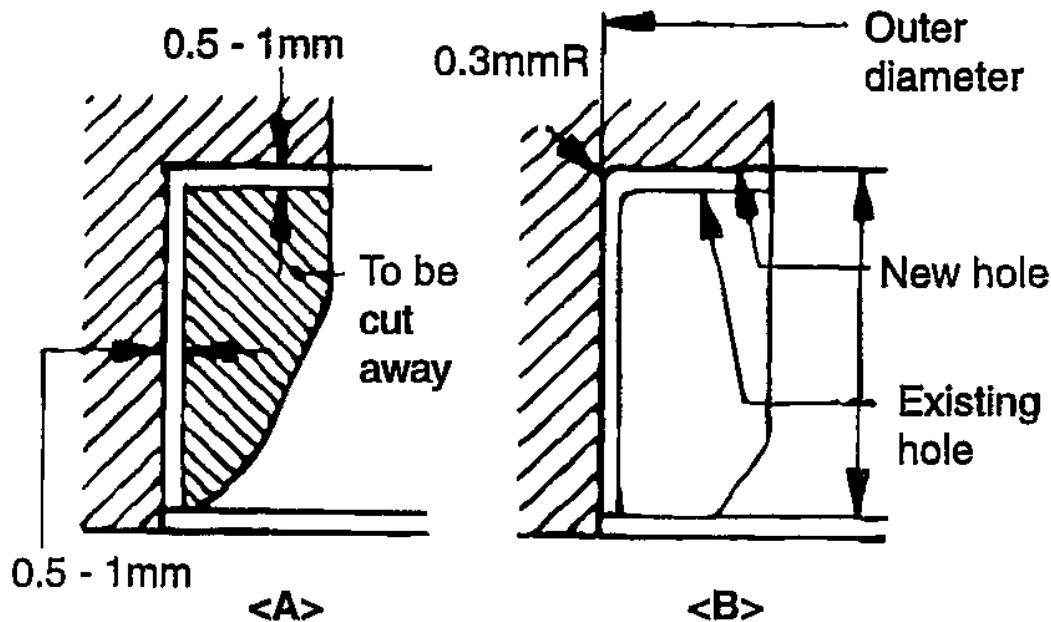

G00320673

Fig. 83: Insert Wall Removal Diagram
 Courtesy of KIA MOTORS AMERICA, INC.

2. After removing the seat insert, match the seat insert bore using a reamer or cutter to the indicated size in the table below.
3. Heat the cylinder head up to 250°C and press in an oversize seat insert. At this time, the temperature of oversize seat insert must be the same as the room temperature. When new valve seat is installed, adjust the valve seat face. For valve seat specifications, see chart in figure 84.

Description	Size (mm)	Size mark	Seat insert height H (mm)	Cylinder head I.D (mm)
Intake valve Seat insert	0.3 O.S.	30	7.5 - 7.7mm (0.2953 - 0.3031 in)	36.30 - 36.325 (1.429 - 1.430 in)
	0.6 O.S.	60	7.8 - 8.0mm (0.3071 - 0.3150 in)	36.60 - 36.625 (1.441 - 1.442 in)
Exhaust valve Seat insert	0.3 O.S.	30	8.0 - 8.2mm (0.3150 - 0.3228 in)	33.30 - 33.325 (1.311 - 1.312 in)
	0.6 O.S.	60	8.3 - 8.5mm (0.3268 - 0.3346 in)	33.60 - 33.625 (1.323 - 1.324 in)

G00320674

Fig. 84: Valve Seat Specifications Chart
 Courtesy of KIA MOTORS AMERICA, INC.

As the valve guide is tightly pressed in, replace the valve guide using following procedure, using the valve guide installer or appropriate tools.

1. Using the push rod of the valve guide installer, push it out of initial position by pushing it to the cylinder block side.
2. Machine insert hole of the cylinder head valve guide to the size of oversize valve guide.
3. Press in the valve guide using the valve guide installer or appropriate tools. By using the valve guide installer, it can be pressed in the specified height.

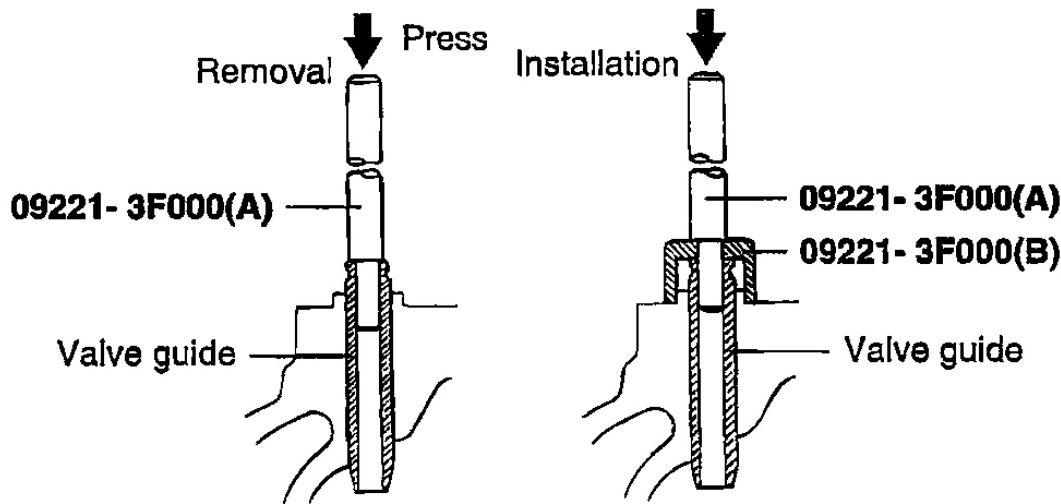

G00320675

Fig. 85: Illustrating Valve Guide Installation Tool
Courtesy of KIA MOTORS AMERICA, INC.

4. Valve guide is to be installed from the upside of the cylinder head.

As length of the intake valve guide is different from that of the exhaust valve guide, be careful. (The lengths of guide for intake valve and exhaust valve are 45.5mm and 50.5mm respectively.)

After installing the valve guide, insert the new valve and check sliding state.

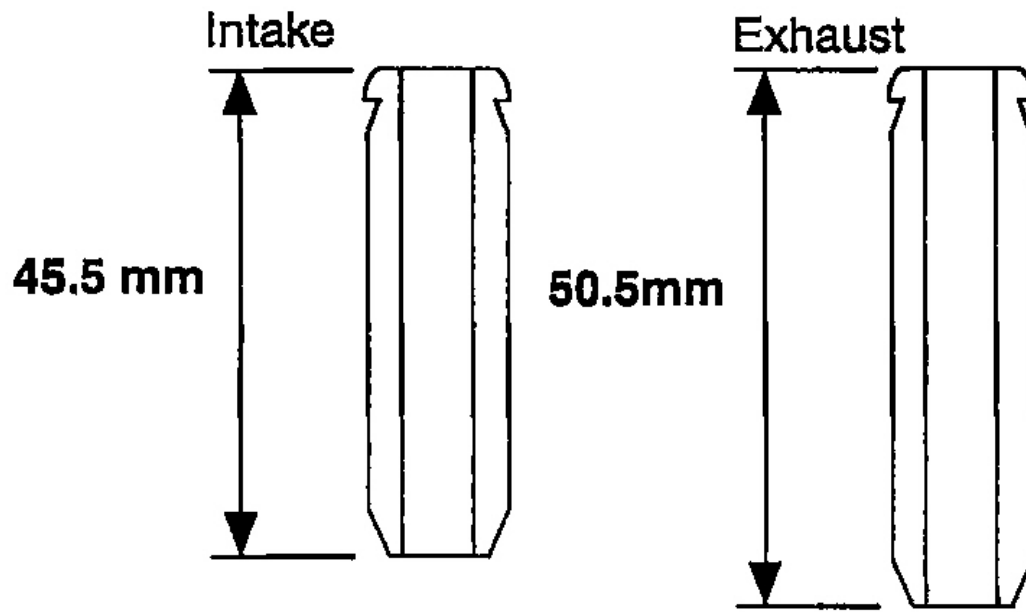

G00320676

Fig. 86: Measuring Valve Guide Length
Courtesy of KIA MOTORS AMERICA, INC.

5. When the valve guide is replaced, inspect for valve contact state. If necessary, adjust the valve seat.

VALVE GUIDE INSERT OVERSIZES

Size (mm)	Size mark	Inner diameter of hole for guide insertion
0.05 O.S.	5	12.05-12.068 mm (0.474 - 0.475 in)
0.25 O.S.	25	12.25-12.268 mm (0.482-0.483 in)
0.50 O.S.	50	12.50-12.518 mm (0.492-0.493 in)

G00320677

Fig. 87: Valve Guide Oversize Chart
 Courtesy of KIA MOTORS AMERICA, INC.

REASSEMBLY

VALVE STEM SEAL

1. Install the valve spring seat.
2. Install a new stem seal on valve guide using the special tool (09222-28200).

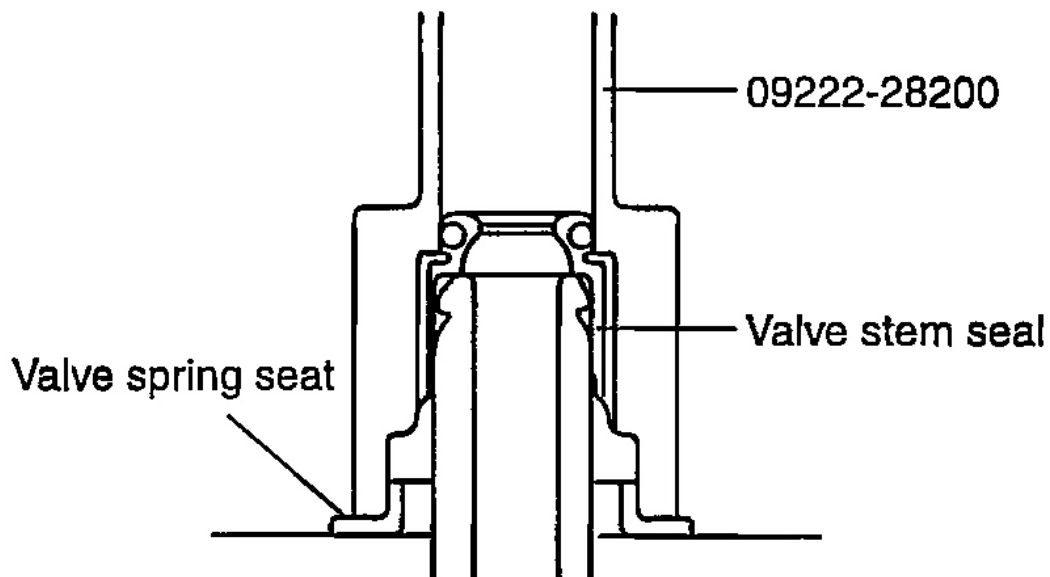

G00320678

Fig. 88: Identifying Valve Stem Seal Position
Courtesy of KIA MOTORS AMERICA, INC.

CAUTION: Valve stem seal should never be reused. Incorrect seal installation can cause oil leakage through lower part of the valve guide. When the valve stem seal is removed due to missing of valve spring seat, the stem seal cannot be reused.

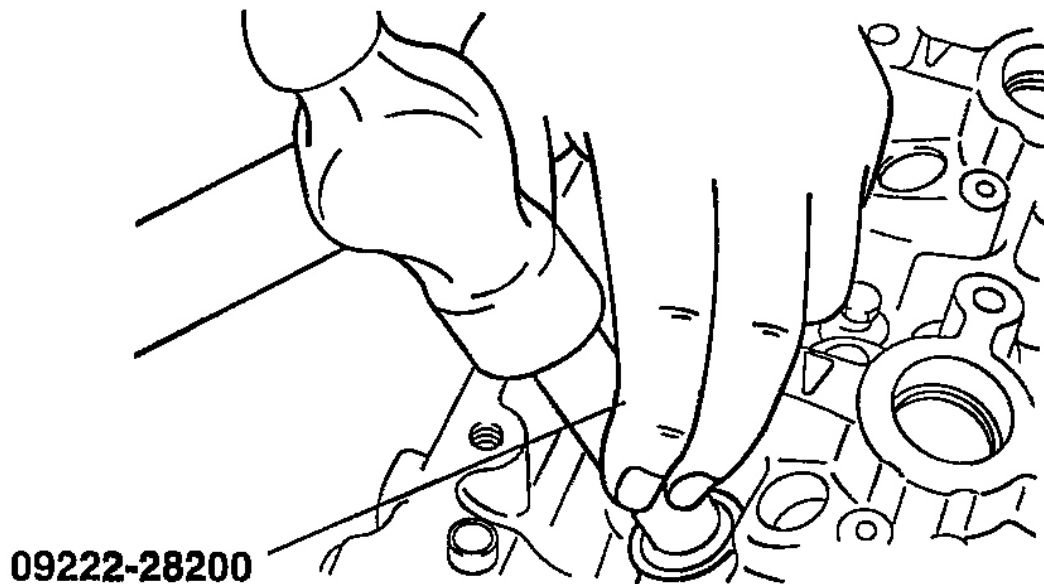

09222-28200

G00320679

Fig. 89: Installing Valve Stem Seal
Courtesy of KIA MOTORS AMERICA, INC.

VALVE SPRING

Install the valve spring so that the end part with identification mark is paced at the end of the spring retainer.

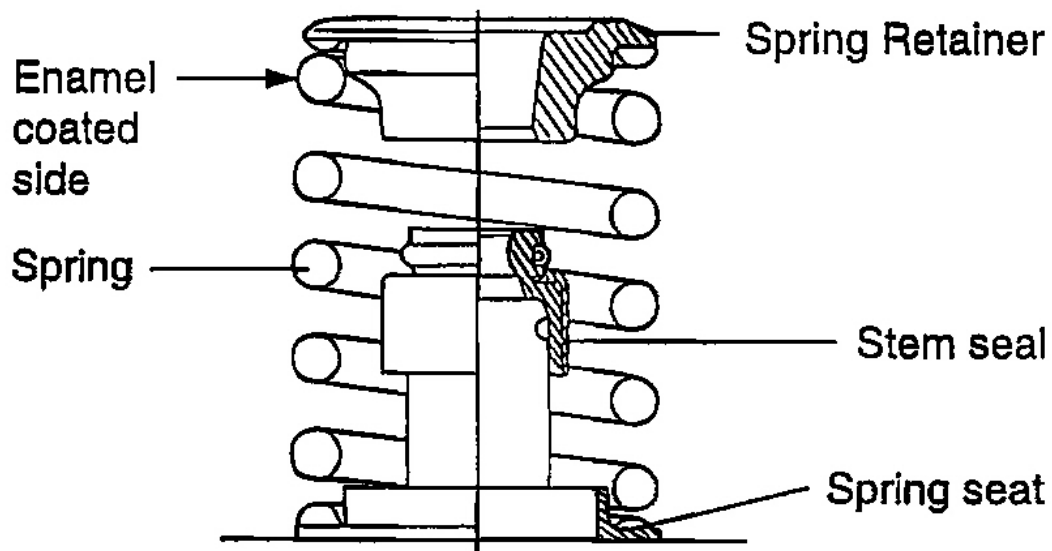

G00320680

Fig. 90: Positioning Valve Spring
Courtesy of KIA MOTORS AMERICA, INC.

RETAINER LOCK

Insert the retainer lock by pressing down the valve spring with special tool (09222-28000).

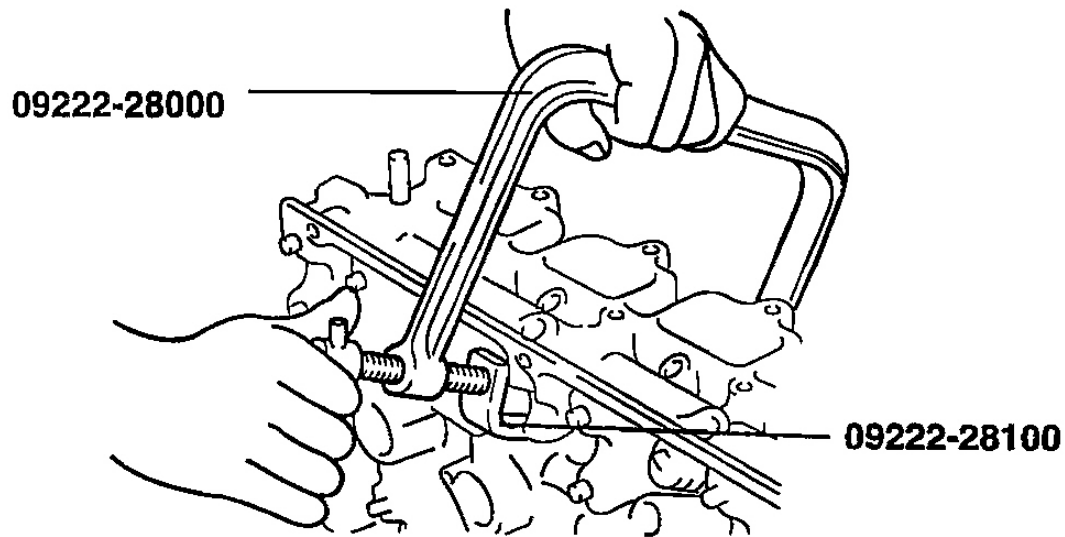

G00320681

Fig. 91: Installing Valve Retainer Lock
Courtesy of KIA MOTORS AMERICA, INC.

INSTALLATION

CYLINDER HEAD GASKET

1. All mating faces for the gasket on the cylinder block and the cylinder head should be cleaned.
2. Install new cylinder head gasket on the cylinder head assembly. Do not smear the sealant on the gasket and only the new gasket must be used.

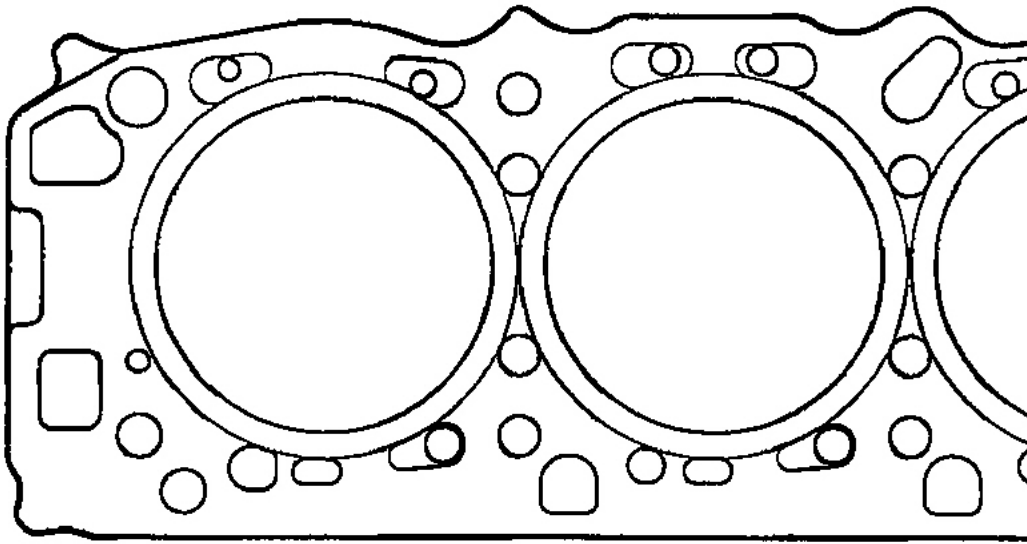

G00320665

Fig. 92: Illustrating Cylinder Head Gasket
Courtesy of KIA MOTORS AMERICA, INC.

CYLINDER HEAD BOLT

1. Tighten the cylinder head bolts as shown in illustration below using the appropriate tool.

Tightening torque: 105-115 N.m (1050-1150 kg.cm, 75.9-83.2 lb.ft)

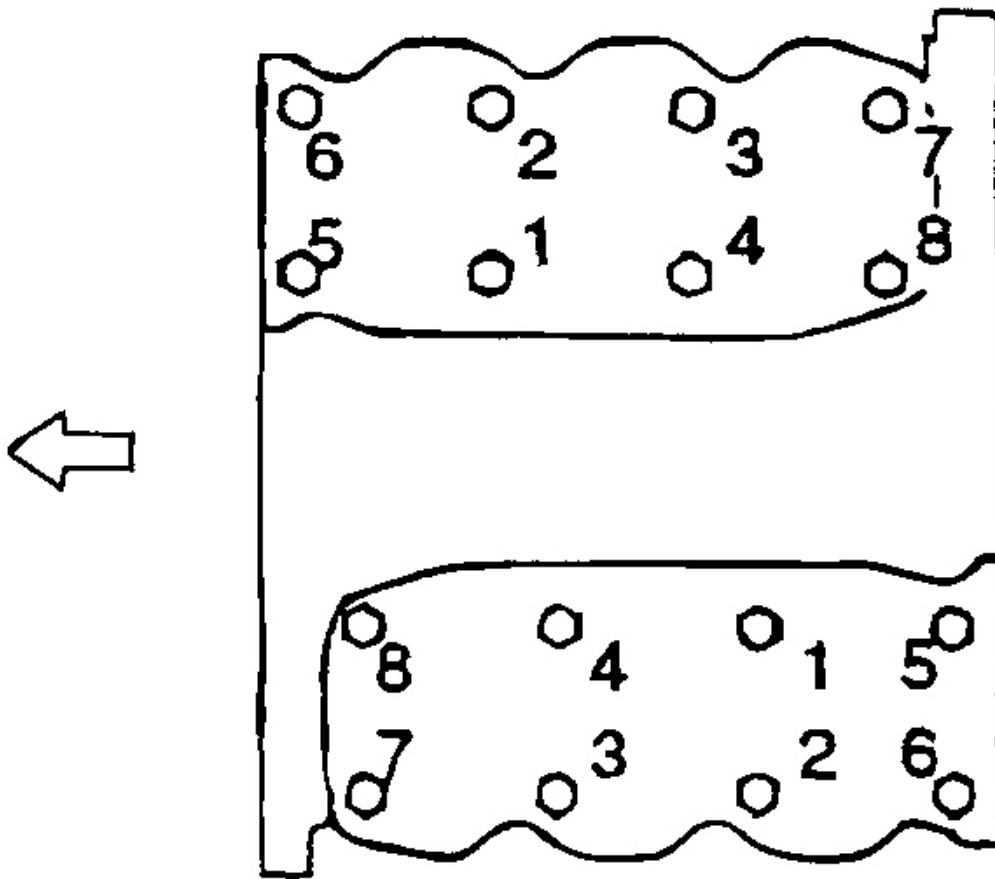

G00320666

Fig. 93: Illustrating Cylinder Head Tightening Sequence
Courtesy of KIA MOTORS AMERICA, INC.

LUBRICATION SYSTEM

COMPONENTS

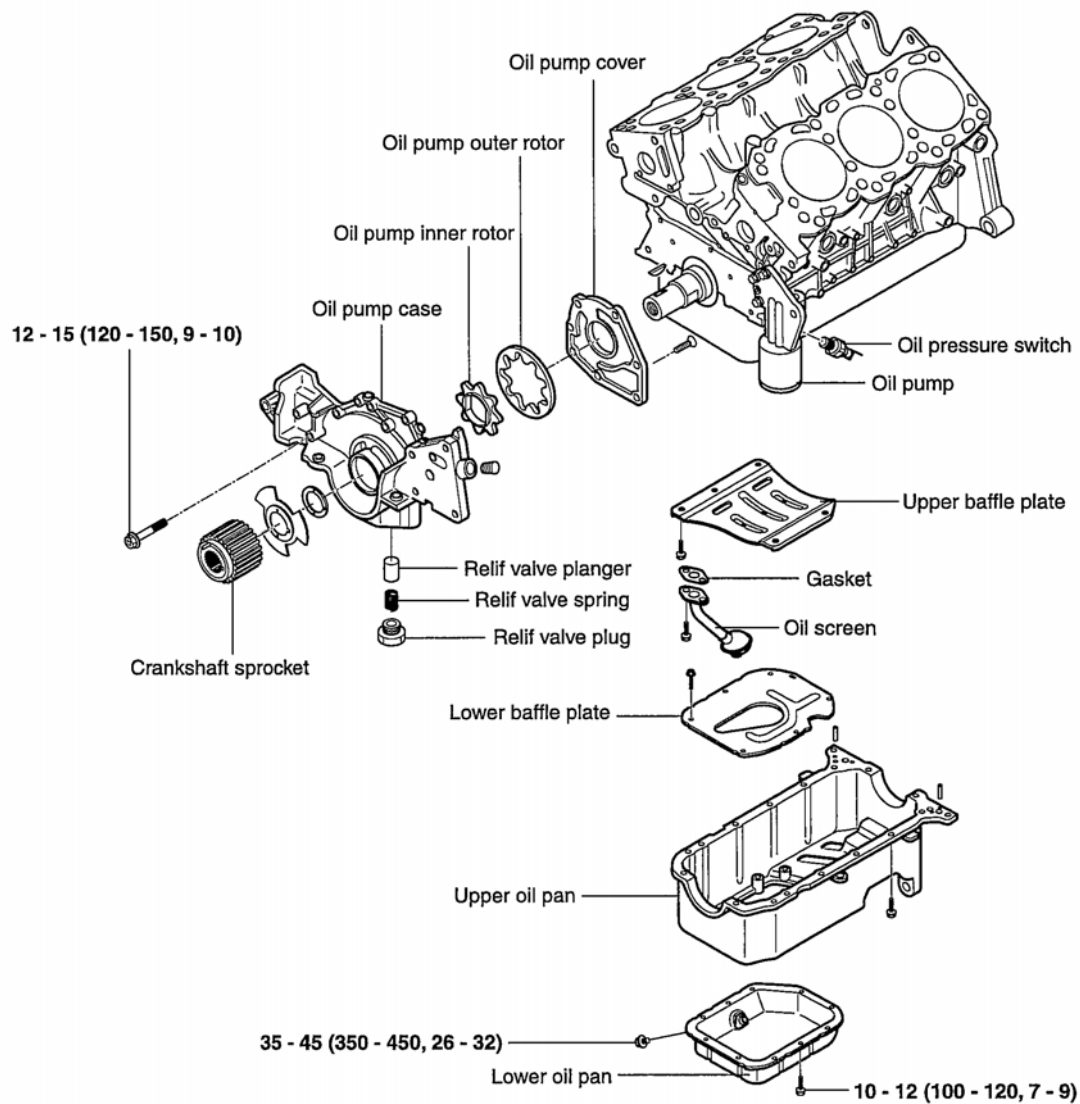

TORQUE : N·m (kg·cm, lb·ft)

G00320626

Fig. 94: Exploded View Of Oil Pump & Oil Pan
 Courtesy of KIA MOTORS AMERICA, INC.

DISASSEMBLY

1. Remove the oil pressure switch, using 24 mm deep socket.

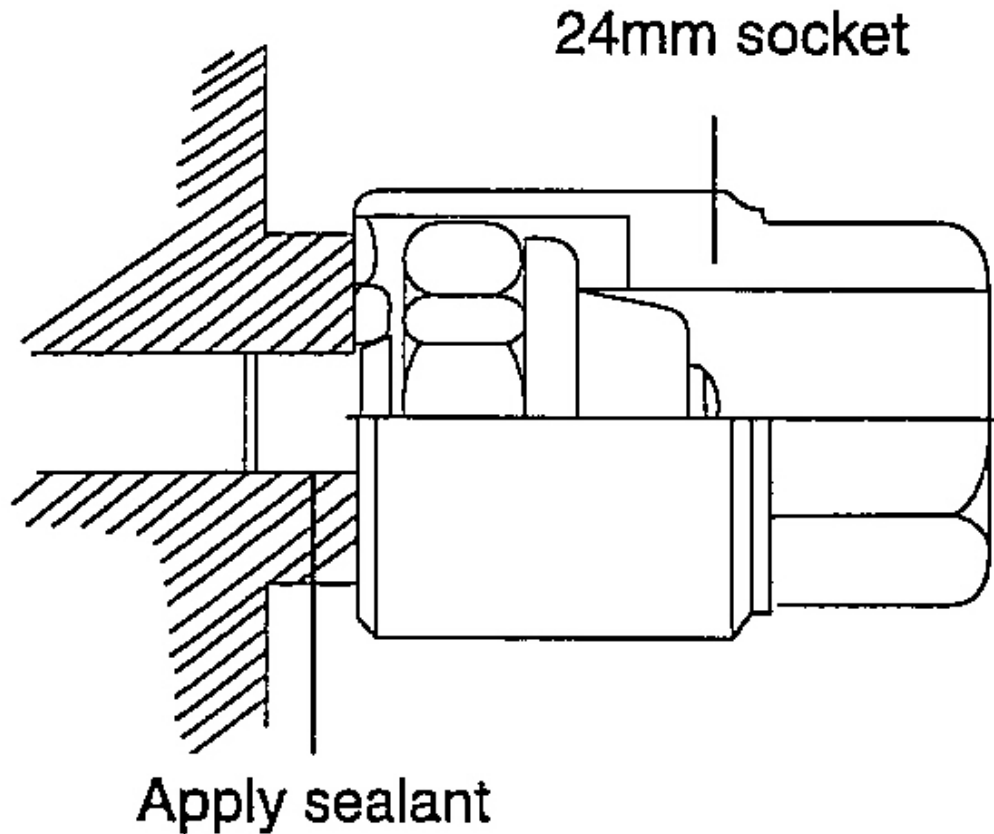

G00320627

Fig. 95: Removing Oil Pressure Switch
Courtesy of KIA MOTORS AMERICA, INC.

NOTE: Since a sealant is used on the threaded area, be careful not to damage the oil pressure switch.

2. Remove the oil filter and the oil pan.
3. Remove the oil screen and gasket.
4. Remove the three bracket securing bolts and remove the oil filter bracket and gasket.
5. Remove the oil relief valve plug from the oil pump case.
6. Remove the oil pump case.

OIL PUMP

1. Visually check the parts of the oil pump case for cracks and damage.
2. Assemble the rotor on the oil pump and then check the clearance with a thickness gauge.

OIL PUMP CLEARANCE

Application	Standard In. (mm)
Body Clearance	0.0039-0.0071 (0.100-0.181)
Side Clearance	0.0016-0.0037 (0.040-0.095)

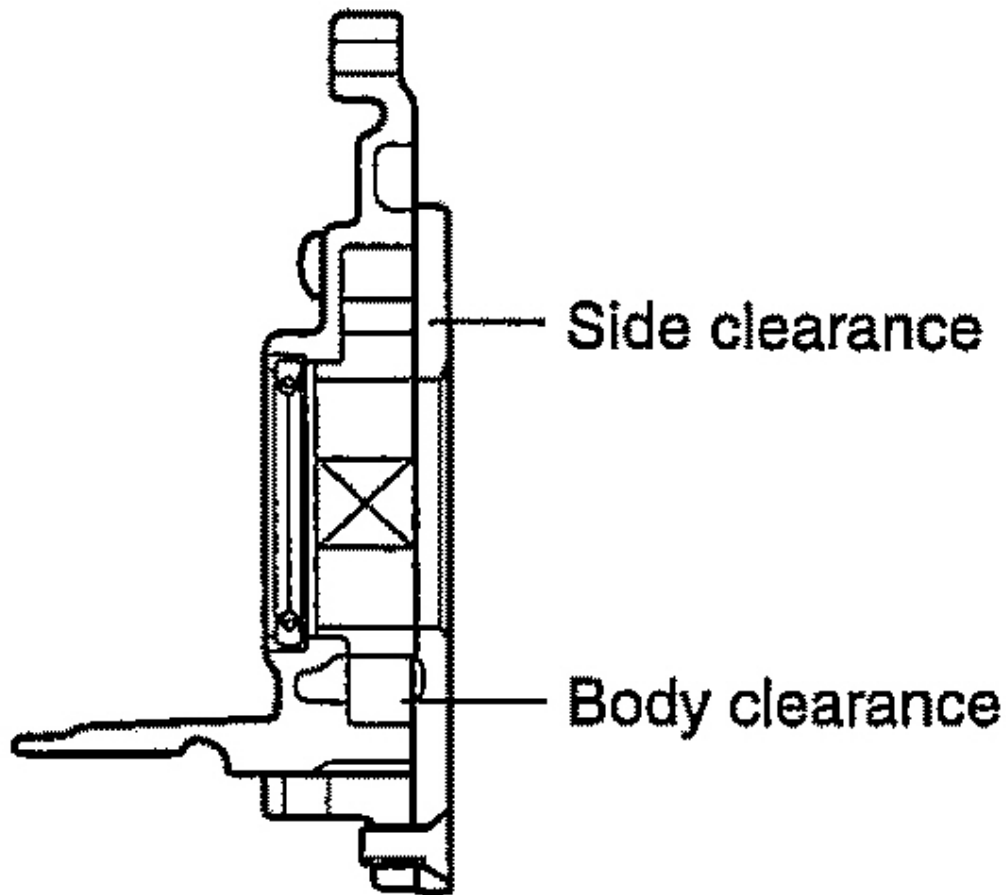

G00320628

Fig. 96: Illustrating Measuring Locations

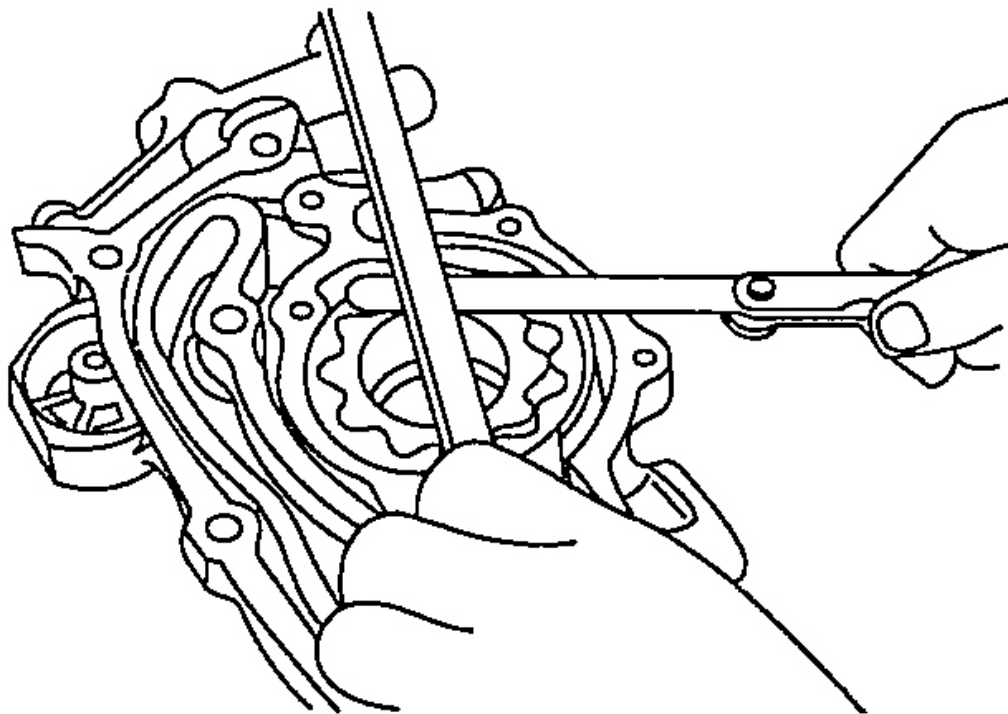

G00320629

Fig. 97: Measuring Side & Body Clearance
Courtesy of KIA MOTORS AMERICA, INC.

RELIEF PLUNGER AND SPRING

1. Check the relief plunger for smooth operation.
2. Check the relief spring for the deformed or broken condition.

OIL FILTER BRACKET

1. Make sure that there is no damage on the oil filter installation surface.
2. Check the oil filter bracket for oil leaks or cracks.

OIL PRESSURE SWITCH

1. Check the continuity by between terminal and body with an ohmmeter.

If there is continuity, replace the oil pressure switch.

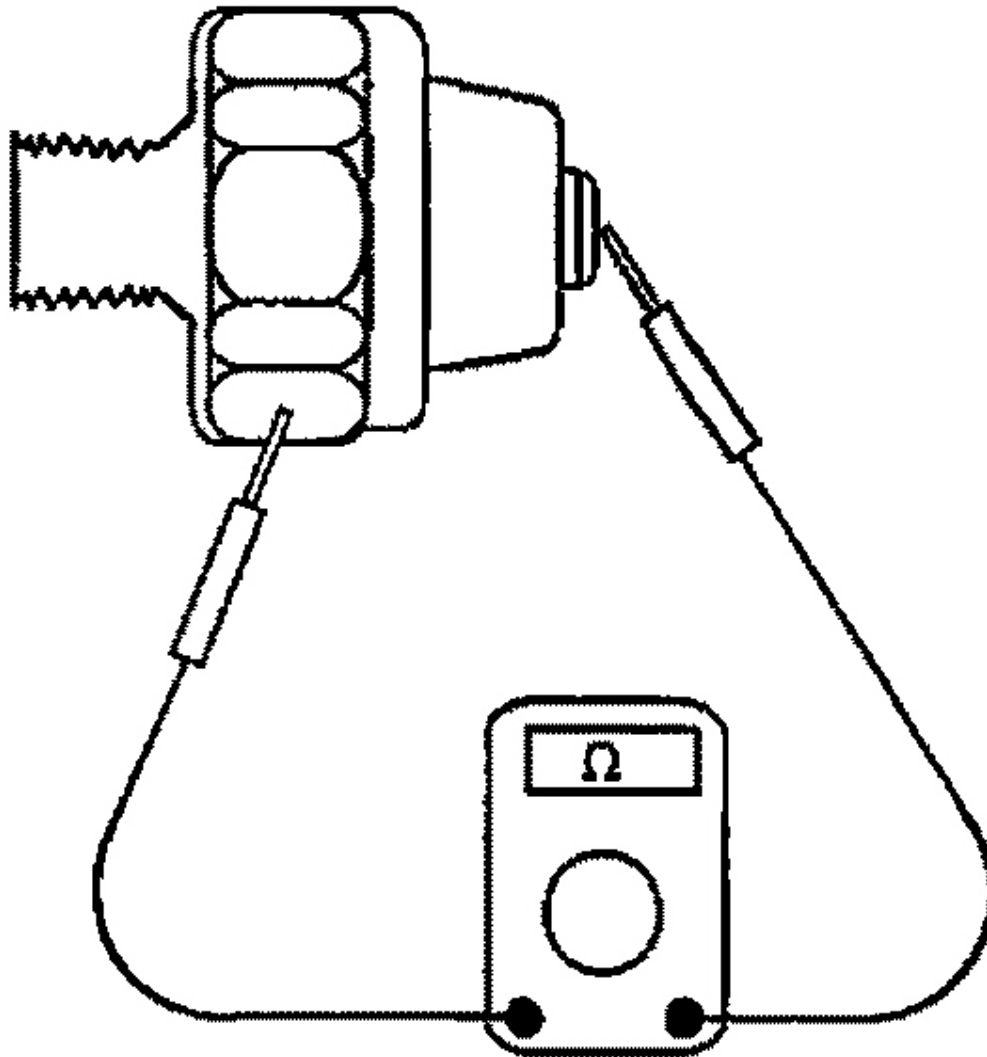

G00320630

Fig. 98: Testing Oil Pressure Switch Continuity
Courtesy of KIA MOTORS AMERICA, INC.

2. Check the continuity between the terminal and the body when the fine wedge is pushed. If there is continuity even when the fine wedge is pushed, replace it.

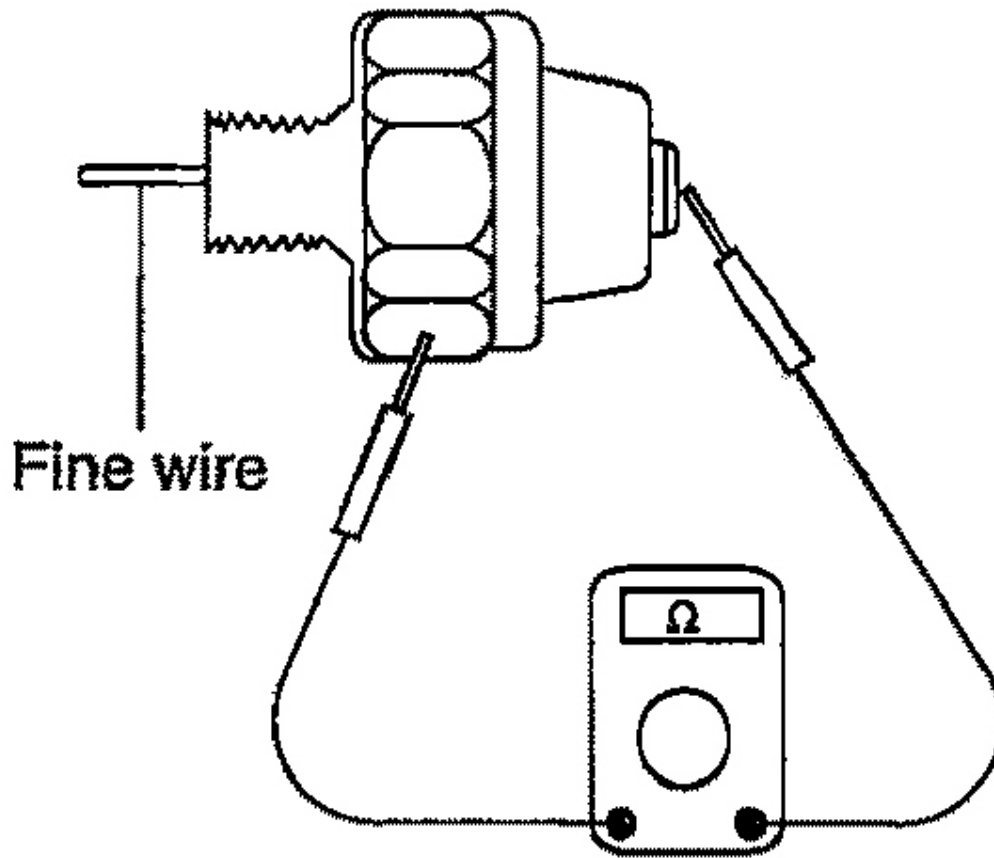

G00320631

Fig. 99: Testing Oil Pressure Switch Continuity When Activated
Courtesy of KIA MOTORS AMERICA, INC.

3. Or, if there is no continuity when a 50kPa (0.5 kg/cm², 7psi) vacuum is applied through the oil hole, the switch is operating properly. Check that air doesn't leak. If air leaks, the diaphragm is broken, replace it.

REASSEMBLY

1. Install the oil pump case with the gasket.

Tightening torque:

Oil pump case bolt: 12-15 N.m (120-150 kg.cm, 8.85-11.06 lb.ft)

Oil pump cover screw: 8-12 N.m (80-120 kg.cm, 5.91-8.85 lb.ft)

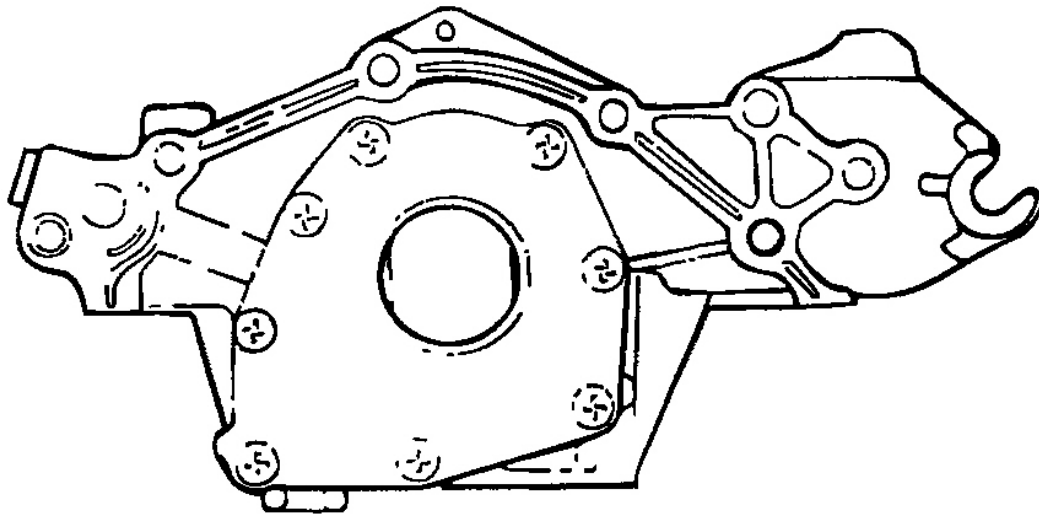

G00320632

Fig. 100: Positioning Oil Pump Case & Gasket
Courtesy of KIA MOTORS AMERICA, INC.

2. Install the oil seal in the oil pump case, using special tool (09214-33000).

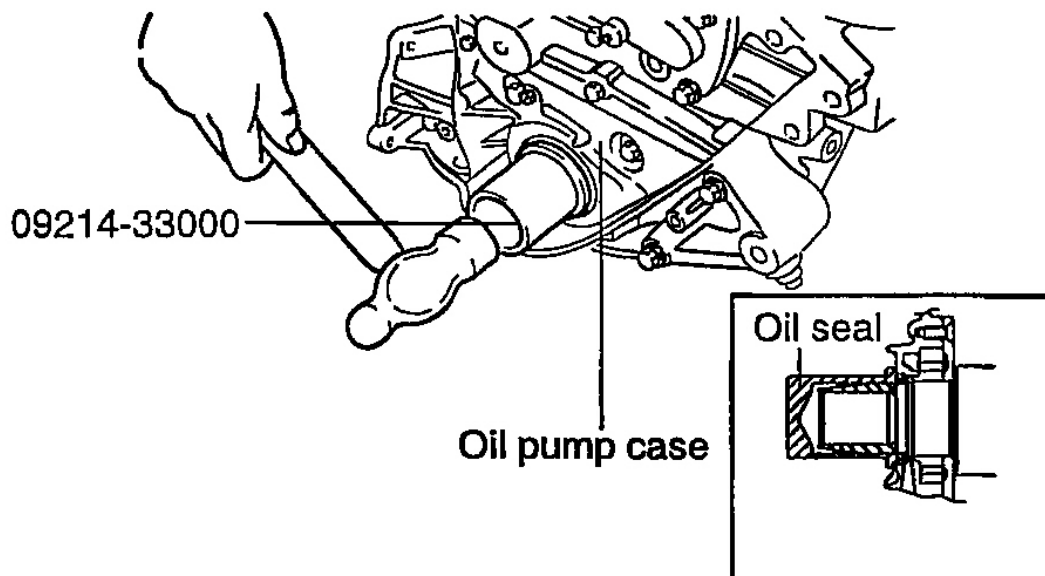

G00320633

Fig. 101: Installing Oil Pump Seal
Courtesy of KIA MOTORS AMERICA, INC.

3. Install the relief plunger and spring, and tighten the oil relief valve plug to the specified torque.

Tightening torque:

Oil relief valve plug: 40-50 N.m (400-500 kg.cm, 29.5-36.88 lb.ft)

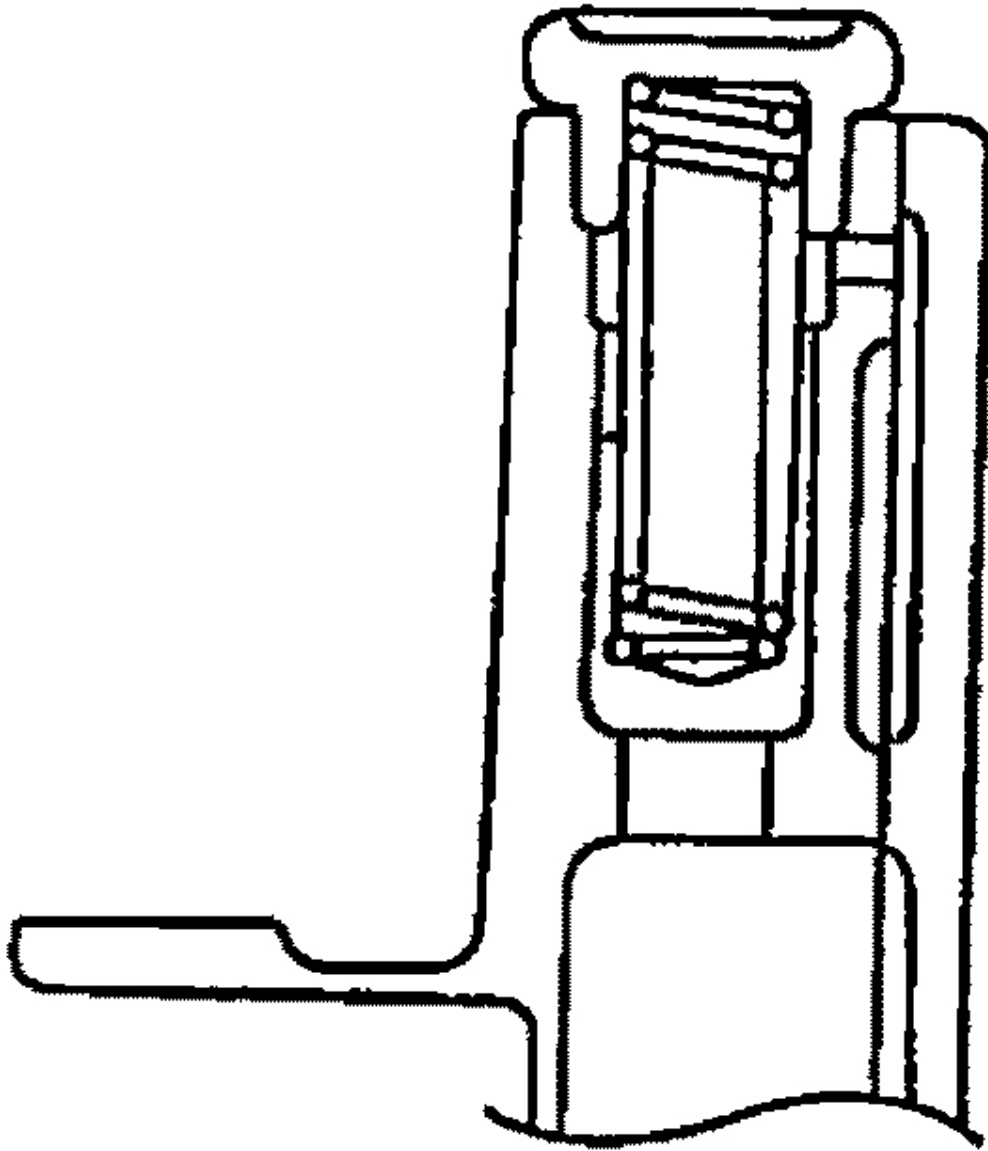

G00320634

Fig. 102: Installing Relief Plunger & Spring
Courtesy of KIA MOTORS AMERICA, INC.

4. Install the oil screen with a new gasket.

Tightening torque

Oil screen bolt: 15-22 N.m (150-220 kg.cm, 11.06-16.23 lb.ft)

5. Clean the gasket surfaces of the cylinder block and the oil pan.
6. Apply sealant into the groove of the oil pan flange.

NOTE: Make the first cut from the end of the nozzle furnished with the sealant approx. 4 mm. After application of the sealant, do not exceed 15 minutes before installing the oil pan.

7. Install the upper oil pan and tighten the bolts to the specified torque. Tighten the oil pan bolts as shown in figure.

Tightening torque

Upper oil pan bolt No.1-14: 9.8-11.8 N.m (100-120 kg.cm, 7.2-8.7 lb.ft) N.m No.15-16: 5-7 (50-70 kg.cm, 3.68-5.16 lb.ft)

Upper oil pan and transaxle mounting bolt (4EA): 30-42 N.m (300-420 kg.cm, 22.13-30.98 lb.ft)

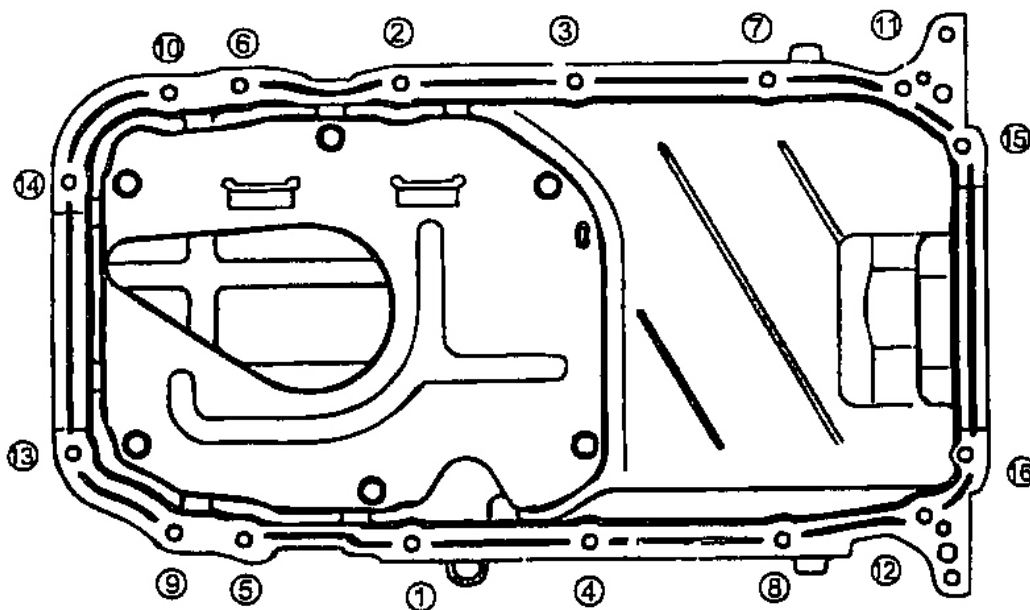

G00320635

Fig. 103: Upper Oil Pan Bolt Tightening Sequence

Courtesy of KIA MOTORS AMERICA, INC.

8. Install the lower oil pan and tighten the bolts to specified torque.

Tightening torque:

Lower oil pan bolt: 9.8-11.8 N.m (100-120 kg.cm, 7.2-8.7 lb.ft)

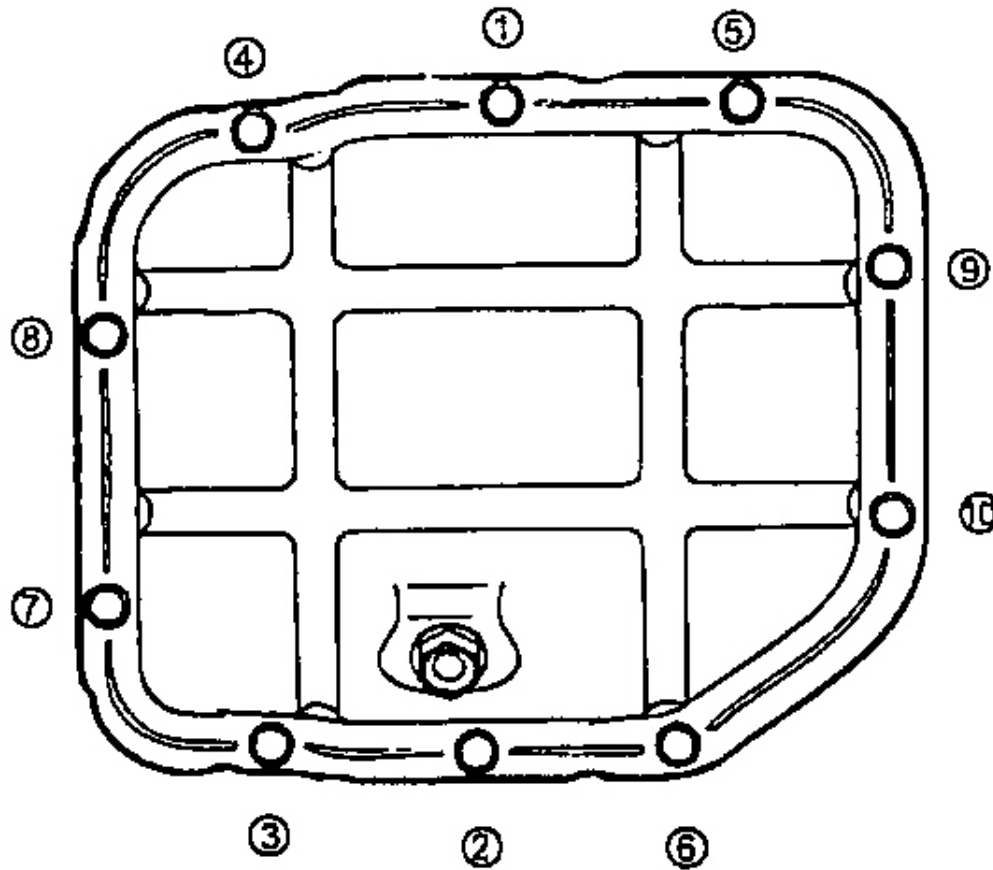

G00320636

Fig. 104: Lower Oil Pan Tightening Sequence
Courtesy of KIA MOTORS AMERICA, INC.

9. Using 24 mm deep socket, install the oil pressure switch after applying sealant to the threaded area.

Sealant: Threebond 1104 or equivalent.

NOTE: Do not tighten the oil pressure switch to the excessive torque.

Oil pressure switch tightening torque: 8-12 N.m (80-120 kg.cm, 5.91-8.85 lb.ft)

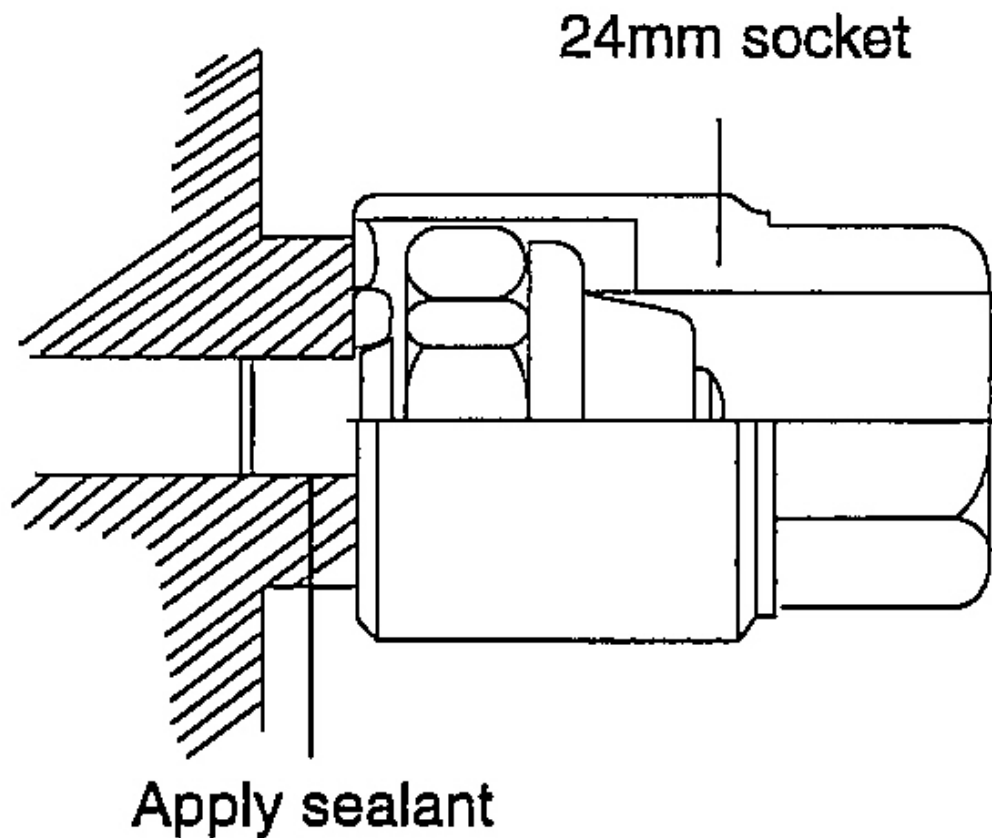

G00320637

Fig. 105: Tightening Oil Pressure Switch
Courtesy of KIA MOTORS AMERICA, INC.

MAIN MOVING SYSTEM

CONNECTING ROD & PISTON ASSEMBLY

COMPONENTS

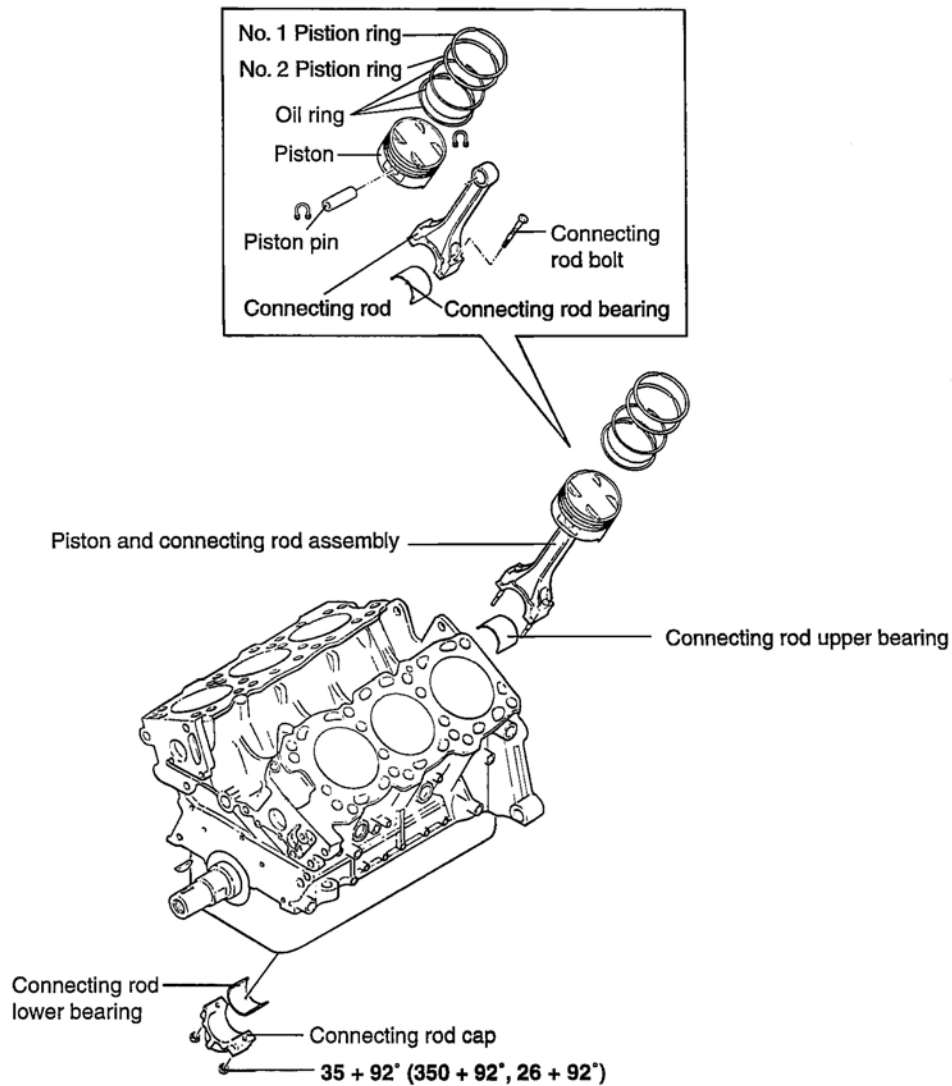

TORQUE : N·m (kg·cm, lb·ft)

G00320554

Fig. 106: Exploded View Of Connecting Rod & Piston Assembly
Courtesy of KIA MOTORS AMERICA, INC.

DISASSEMBLY

CONNECTING ROD CAP

CAUTION: Keep the bearings in order with their corresponding connecting rods (according to cylinder numbers) for proper reassembly.

1. Remove the connecting rod cap bolts, then remove the caps and the big end lower bearing mark for reassembly.
2. Push each piston connecting rod assembly toward the top of the cylinder.

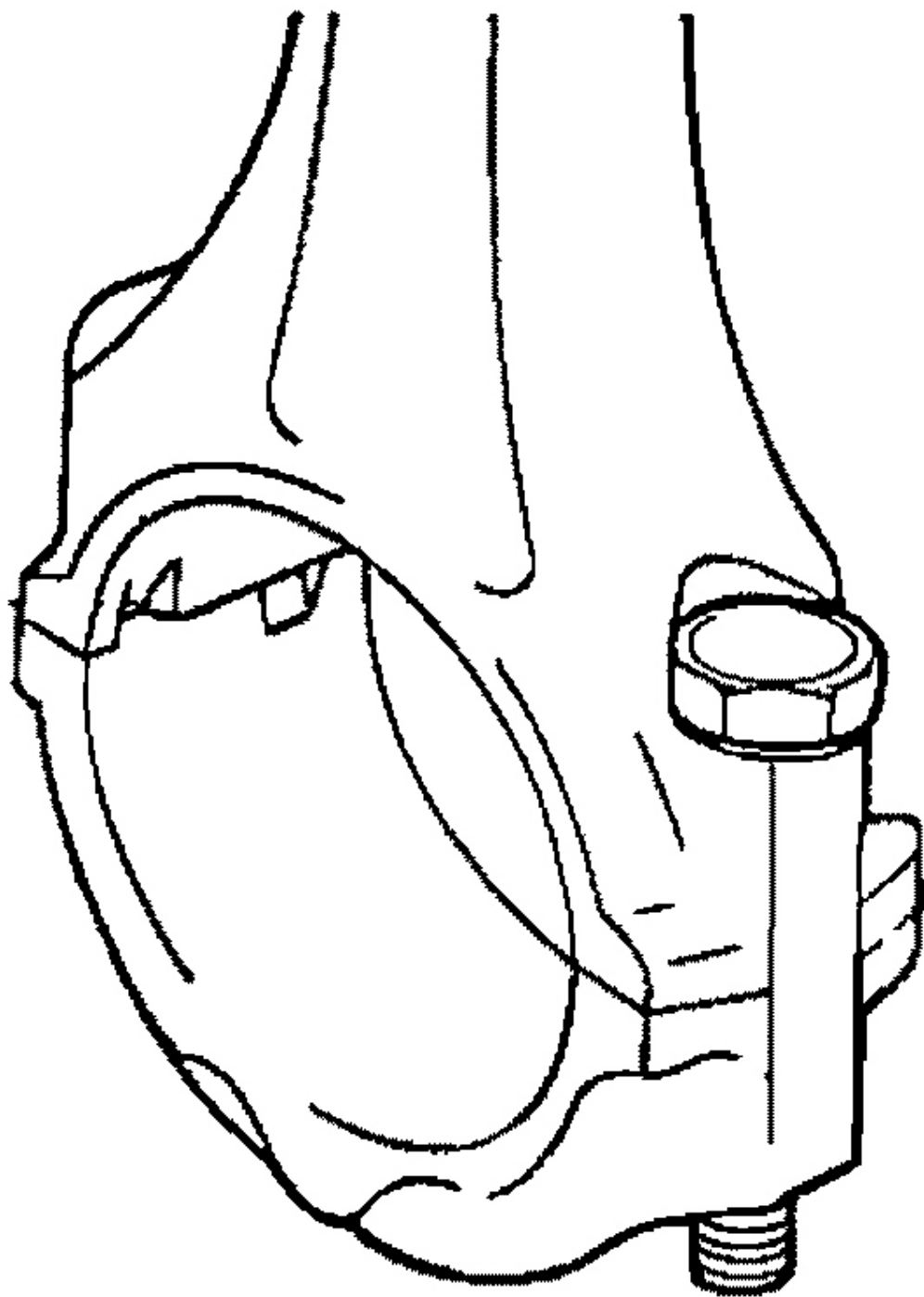

G00320555

Fig. 107: Marking Connecting Rod Assemblies
Courtesy of KIA MOTORS AMERICA, INC.

PISTON PIN REMOVAL & INSTALLATION

1. Use the appropriate tool to disassemble piston and connecting rod.

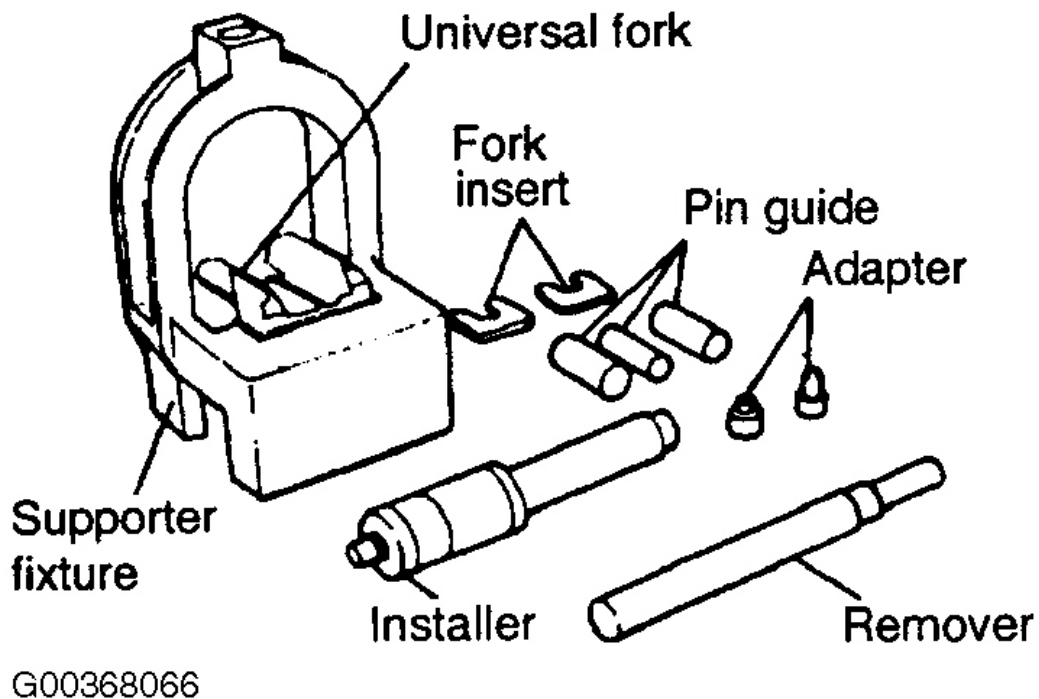
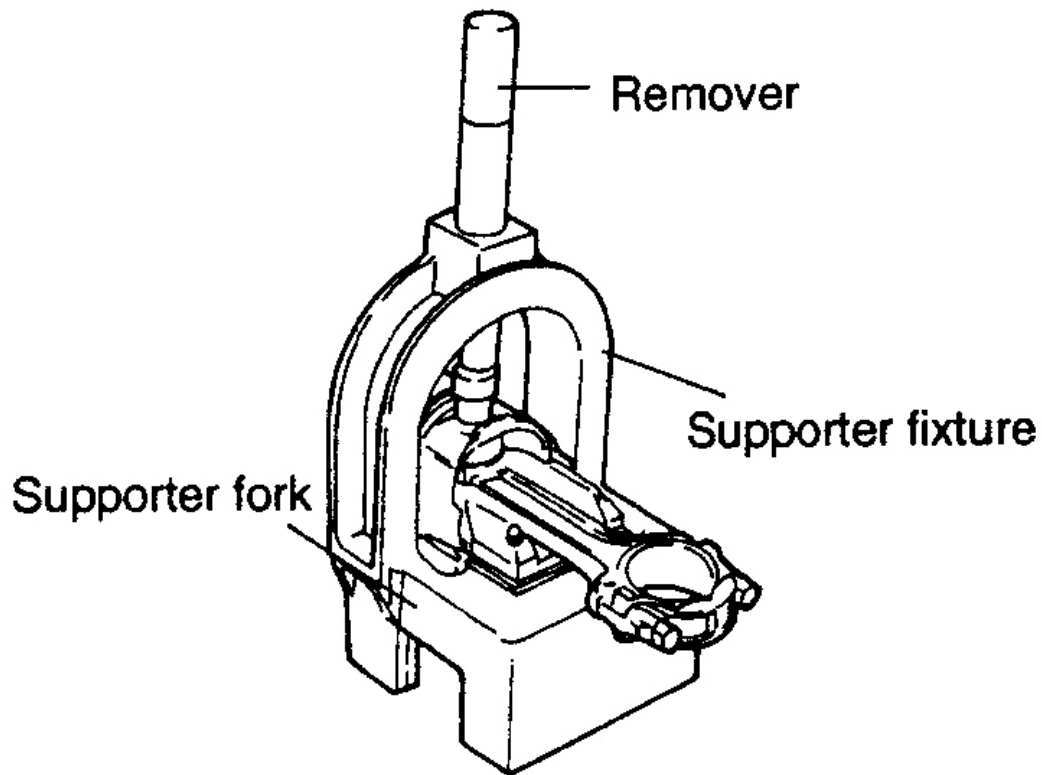

Fig. 108: Illustrating Removal & Installation Tools
Courtesy of KIA MOTORS AMERICA, INC.

2. Place the proper insert tool between the connecting rod and piston.
3. Insert the proper removing tool through the hole.

CAUTION: After removing the piston rod pin assembly, put in the center of the arbor.



G00368067

Fig. 109: Piston Pin Removal Fixture
Courtesy of KIA MOTORS AMERICA, INC.

4. Press the piston pin out of the connecting rod.
5. Install proper pin guide through piston into connecting rod. Hand tap pin guide into piston for proper retention. Install piston pin into the other side of the piston.

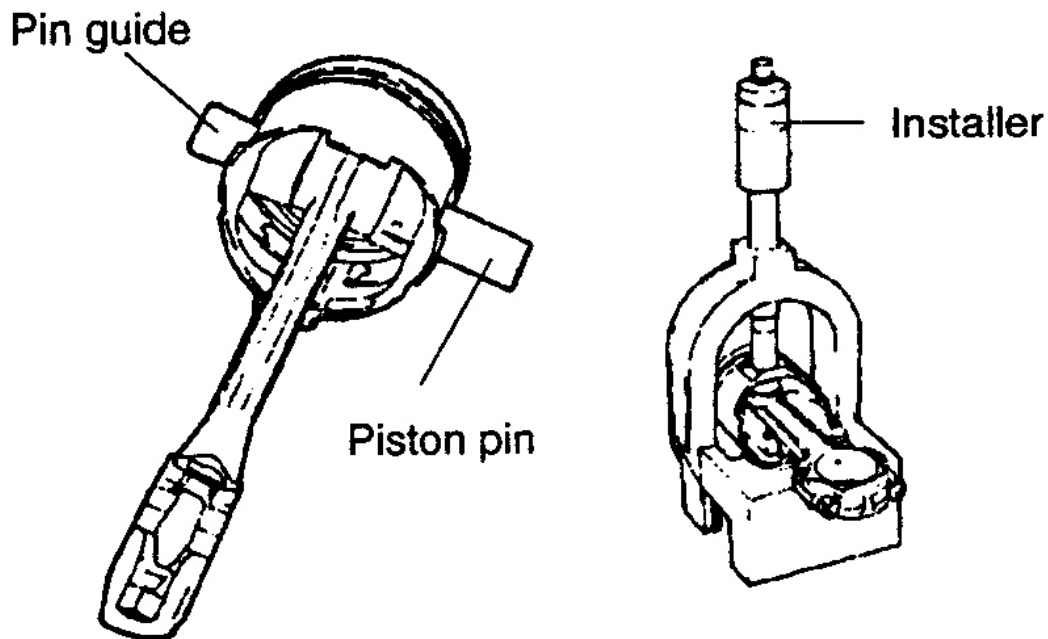

G00368068

Fig. 110: Piston Pin Installation Fixture
Courtesy of KIA MOTORS AMERICA, INC.

CAUTION: The pin guide centers on the connecting rod in the piston. When the piston, connecting rod, piston pin and pin guide assembly are positioned on the fork tool, the guide pin will also center on the tool assembly. If a pin guide that is too small is used, the piston assembly will not be located at the center of the tool and may cause the fork and/or the insert of the tool to be damaged.

6. Install piston assembly on the fork assembly of tool. Tool will support connecting rod at the piston pin. Be sure the piston assembly is slid onto the fork until the pin guide contacts the fork insert.

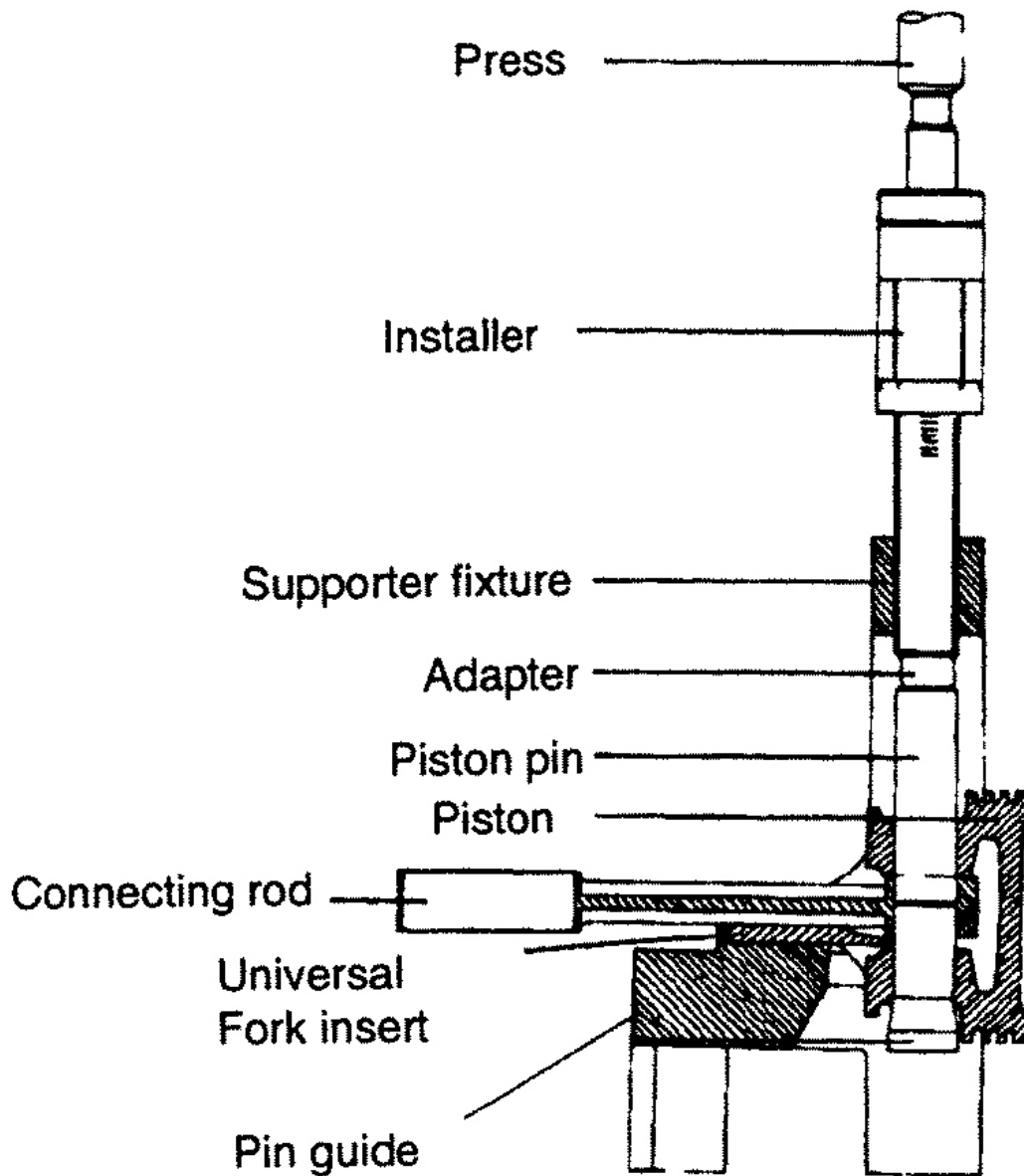

G00368069

Fig. 111: Illustrating Fixture Set-Up
 Courtesy of KIA MOTORS AMERICA, INC.

7. Adjust the installing arbor to the proper length by turning the numbered sleeve on the lettered shaft until the specified alphanumeric is obtained.
8. Insert the installing tool through the hole in the arch of the tool. Press the piston pin into the connecting rod until the sleeve in the installing arbor contacts the top of the tool arch. The pin guide will fall out of

the connecting rod as the piston pin is pressed in.

CAUTION: Do not exceed 5000 pounds of force when stopping the installation arbor sleeve against the arch.

INSPECTION

PISTONS AND PISTON PINS

1. Check each piston for scuffing, scoring, wear and other defects. Replace any piston that is defective.
2. Check each piston ring for breakage, damage and abnormal wear. Replace the defective rings. When the piston requires replacement, its rings should also be replaced.
3. Check that the piston pin fits in the piston pin hole. Replace any piston and pin assembly that is defective. The piston pin must be pressed smoothly by hand into the pin hole (at room temperature).

PISTON RINGS

1. Measure the piston ring side clearance. If the measured value exceeds the service limit, insert a new ring in the ring groove the measure the side clearance. If the clearance still exceeds the service limit, replace the piston and rings together. If it is less than the service limit, replace only the piston rings.
 - Piston ring side clearance ring No. 1: 0.04-0.08 mm (0.0016-0.0031 in.) Limit 0.01 mm (0.0039 in.)
 - Piston ring side clearance ring No. 2: 0.02-0.06 mm (0.0008-0.0024 in.) Limit 0.01 mm (0.0039 in.)

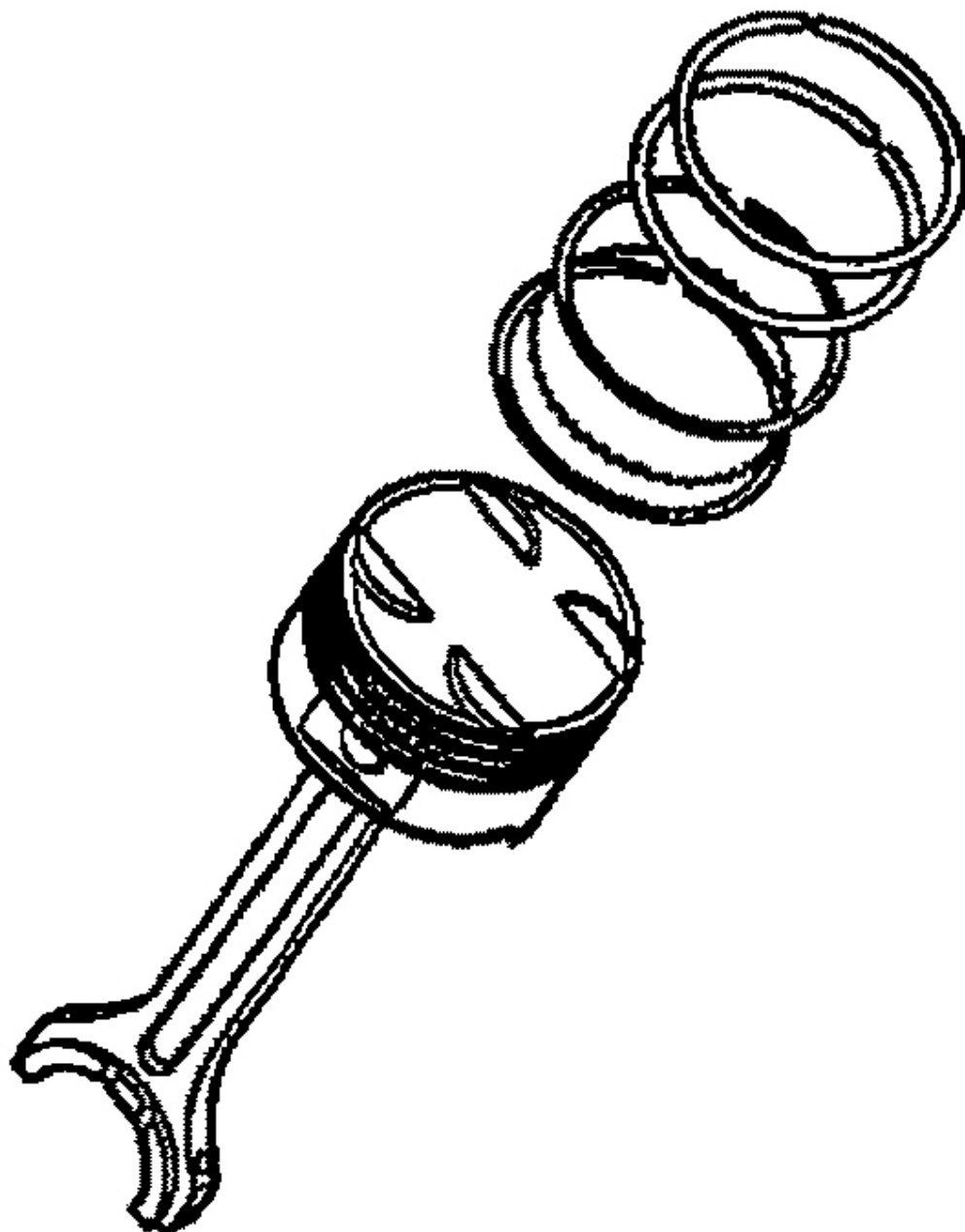

G00320557

Fig. 112: Exploded View Of Piston Rings
Courtesy of KIA MOTORS AMERICA, INC.

2. To measure the piston ring end gap, insert a piston ring into the cylinder bore. Position the ring at right angles to the cylinder wall by gently pressing it down with a piston. Measure the gap with a feeler gauge. If the gap exceeds the service limit, replace the piston ring.
 - Piston ring end gap No. 1: 0.2-0.3 mm (0.0079-0.0118 in.). Limit 0.8 mm (0.031 in.)
 - Piston ring end gap No. 2: 0.45-0.60 mm (0.0177-0.236 in.) Limit 0.8 mm (0.031 in.)
 - Oil ring side rail: 0.2-0.7 mm (0.0079-0.0276) Limit 1.0 mm (0.039 in.)
 - When replacing the ring without correcting the cylinder bore, check the gap with the ring situated at the lower part of cylinder that is less worn.
3. When replacing the ring without correcting the cylinder bore, check the gap with the ring positioned at the lower part of the cylinder that is the less worn. When replacing a ring, be sure to use a ring of the same size.

PISTON RING MARK & LIMIT

Mark	Limit Standard In. (mm)
OS 25	0.25 mm
OS 50	0.50 mm
OS 75	0.75 mm
OS 100	0.100 mm

NOTE: The mark can be found on the upper side of the ring next to the end.

CONNECTING RODS

1. When the connecting rod cap is installed, make sure that the cylinder numbers, marked on rod end cap at disassembly, match. When a new connecting rod is installed, make sure that the notches holding the bearing in place are on the same side.
2. Replace the connecting rod if it is damaged at either end of the thrust faces. If it has a wear, or if the surface of the inside diameter of the small end is severely rough, replace the rod.

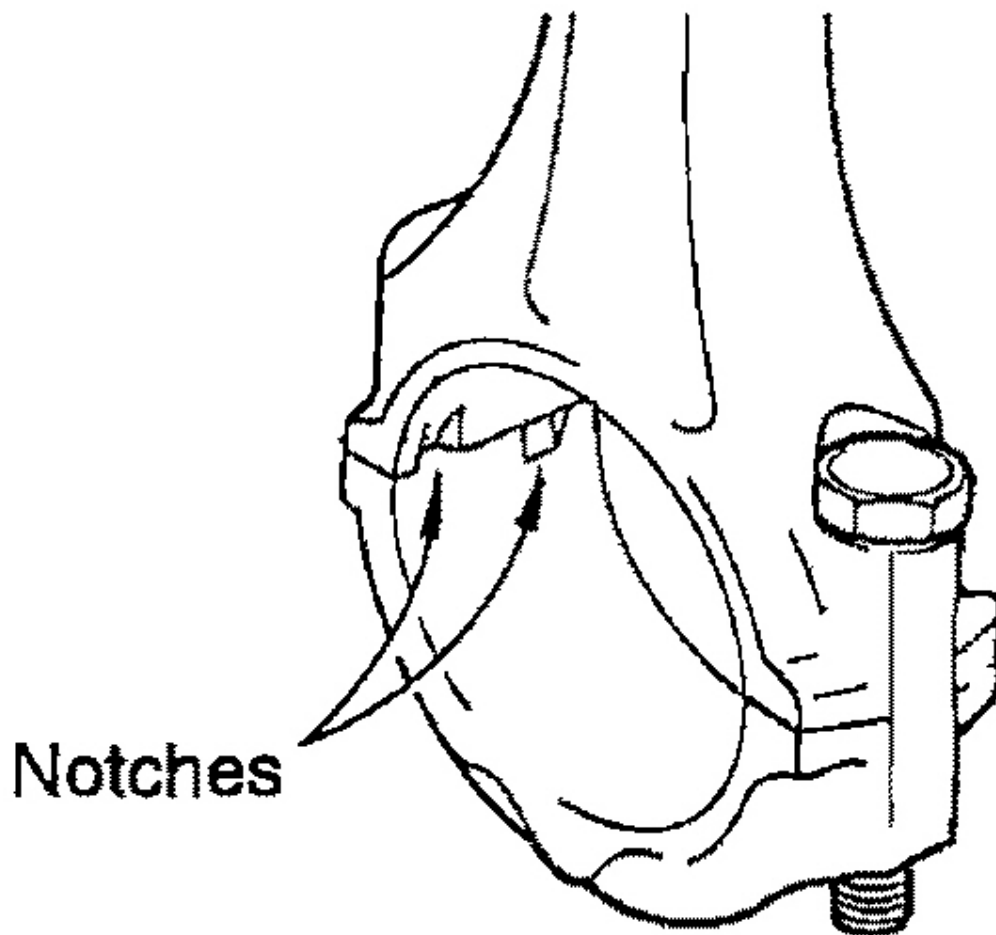

G00320558

Fig. 113: Positioning Connecting Rod Bearing
Courtesy of KIA MOTORS AMERICA, INC.

REASSEMBLY

1. Install the expander.

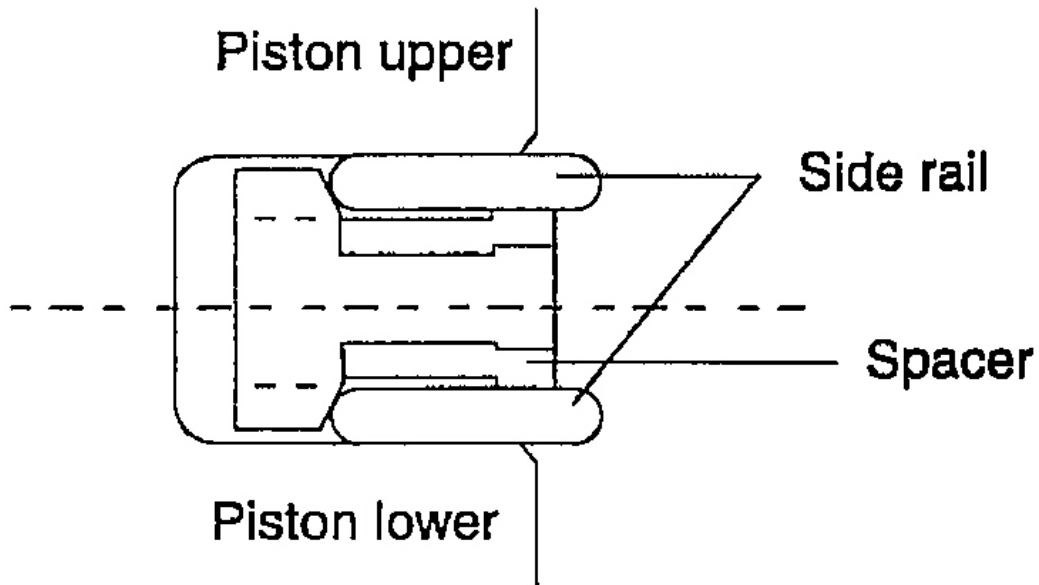

G00320559

Fig. 114: Positioning Oil Ring

Courtesy of KIA MOTORS AMERICA, INC.

2. Install the upper side rail. To install the side rail, first put one end of the side rail between the piston ring groove and spacer, hold it firmly, and press down with finger on the portion to be inserted into the groove. See **Fig. 115** .

CAUTION: Do not use a piston ring expander when installing the side rail.

3. Install the lower side rail by the same procedure described above.

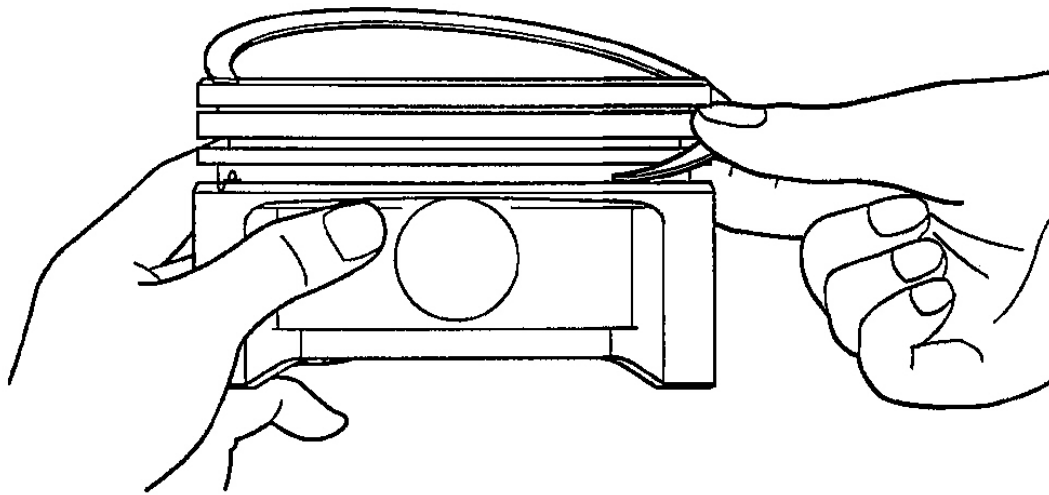

G00320561

Fig. 115: Installing Oil Ring Side Rail
 Courtesy of KIA MOTORS AMERICA, INC.

4. Apply engine oil around the piston and piston grooves.
5. Using a piston ring expander, install the No. 2 piston ring.
6. Install the No. 1 piston ring.

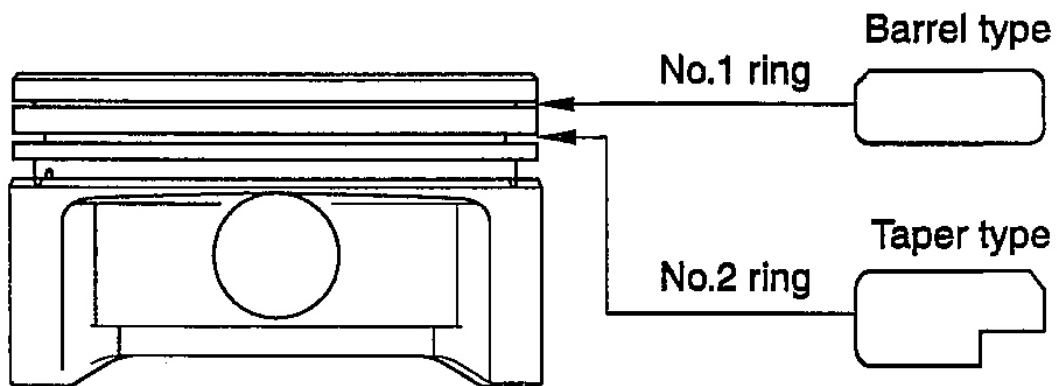

G00320562

Fig. 116: Installing Piston Rings
 Courtesy of KIA MOTORS AMERICA, INC.

7. Position each piston ring end gap as far away from its neighboring gaps as possible. Make sure that the gaps are not positioned in the thrust and pin directions.

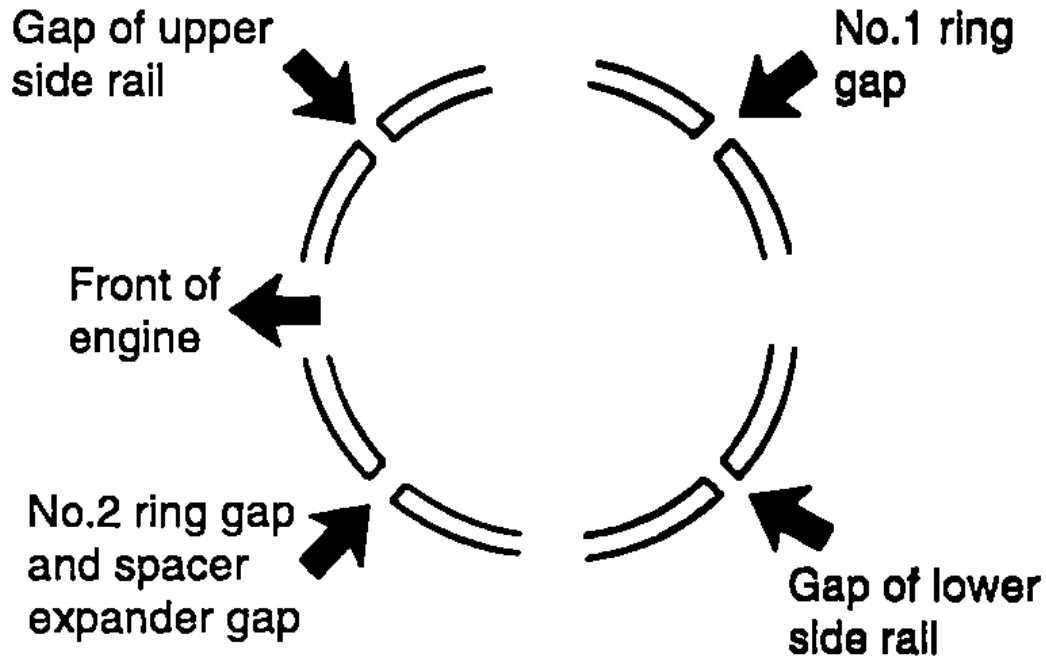

G00320563

Fig. 117: Positioning Piston Rings
Courtesy of KIA MOTORS AMERICA, INC.

8. Hold the piston rings firmly with a piston ring compressor as they are inserted into cylinder.
9. Install the upper connecting rod bearings into the connecting rod.
10. Install the lower connecting rod bearings into the connecting rod bearing caps.
11. Make sure that the front mark of the piston and the front mark (identification mark) of the connecting rod are directed toward the front of the engine.
12. When the connecting rod cap is installed, make sure that any cylinder numbers placed on the rod and cap at disassembly match.
13. When a new connecting rod is installed, make sure that the notches for holding the bearing in place are on the same side.

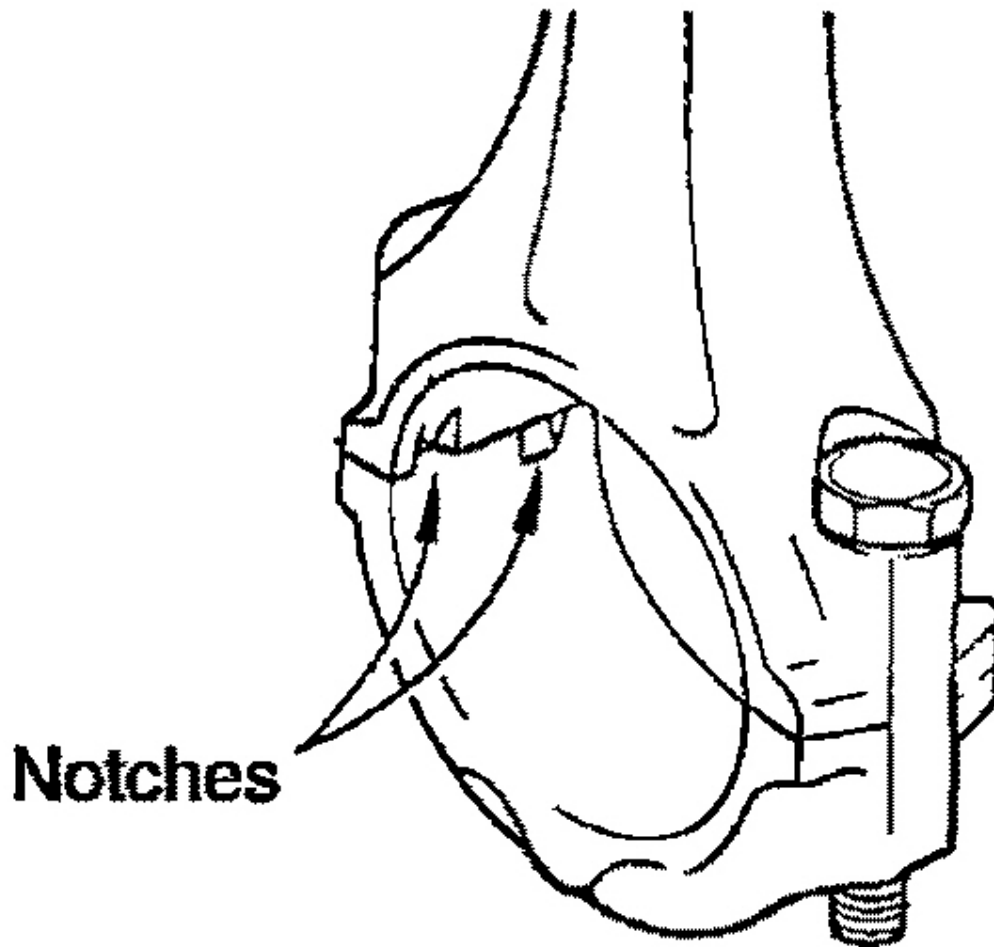

G00320564

Fig. 118: Positioning Connecting Rod Bearing Cap
Courtesy of KIA MOTORS AMERICA, INC.

14. When assembling, bolts should be fastened using the following technique.
 - a. Apply oil to the threads and matching areas.
 - b. Tighten the connecting rod bolt.

Connecting rod bolt, tightening torque: 35 N.m + 92° (350 kg.cm + 92°, 26 lb.ft + 92°)

CAUTION: After removing the connecting rod bolt, do not use it again. When using a new bolt, do not tighten the bolt more than 3 times.

15. Check the bearing clearance as follows:
 - a. Remove oil and dirt from the bearings and journals.
 - b. Cut plastigauge to the same length as the width of the bearing and place it in parallel with the journal, avoiding the oil holes.
 - c. Install the bearing and cap. Tighten to the specified torque. During this operation, do NOT turn the crankshaft.
 - d. Remove the cap, measure at the widest part by using the scale printed on the plastigauge package.

Connecting rod cap bearing clearance, standard value :0.022-0.040 mm (0.0009-0.0016 in).

Limit: 0.1 mm (0.0039 in)

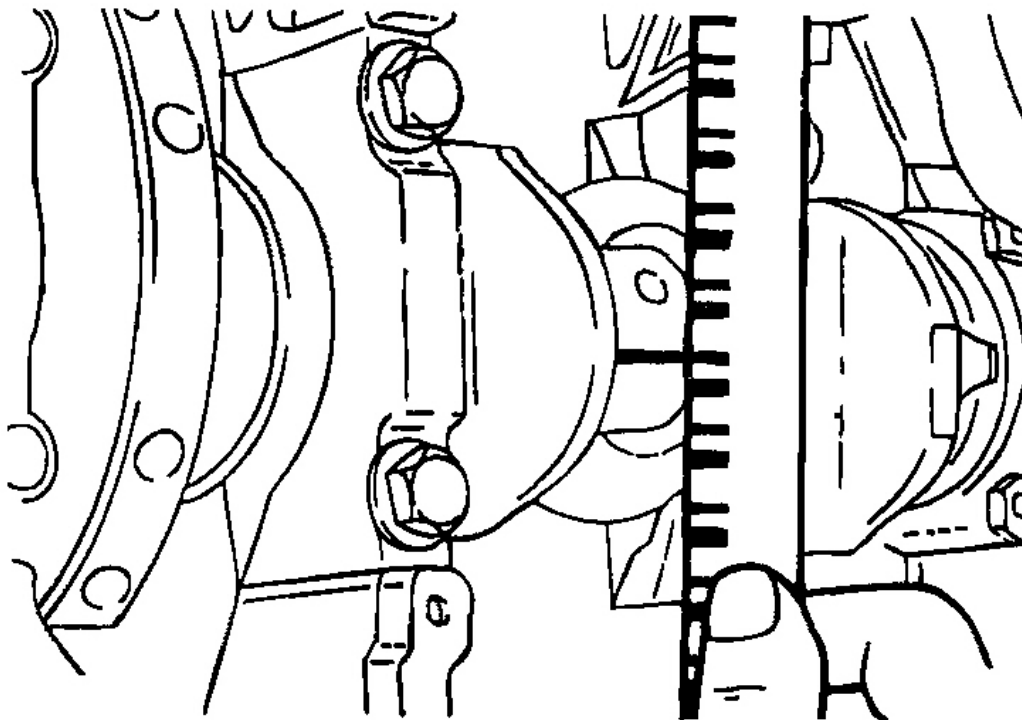

G00320565

Fig. 119: Measuring Bearing Clearance
Courtesy of KIA MOTORS AMERICA, INC.

16. Check the connecting rod side clearance.

Connecting rod side clearance, standard: 0.10-0.25 mm (0.0039-0.0098 in.)

Limit: 0.4 mm (0.0157 in.)

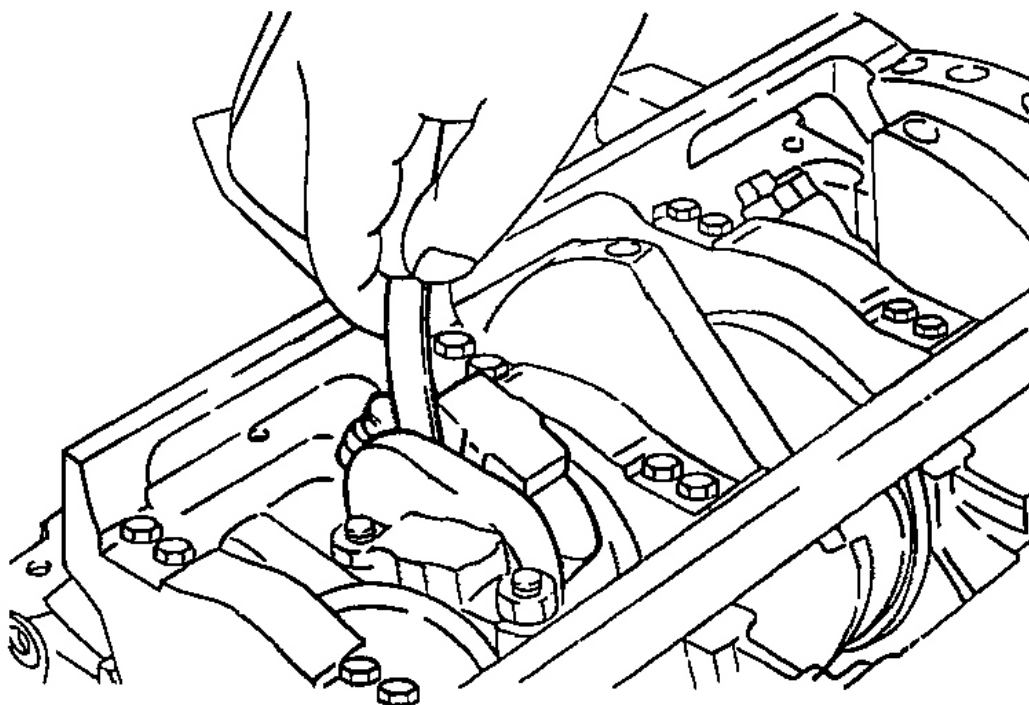

G00320566

Fig. 120: Measuring Bearing Side Clearance
Courtesy of KIA MOTORS AMERICA, INC.

CRANK SHAFT

COMPONENTS

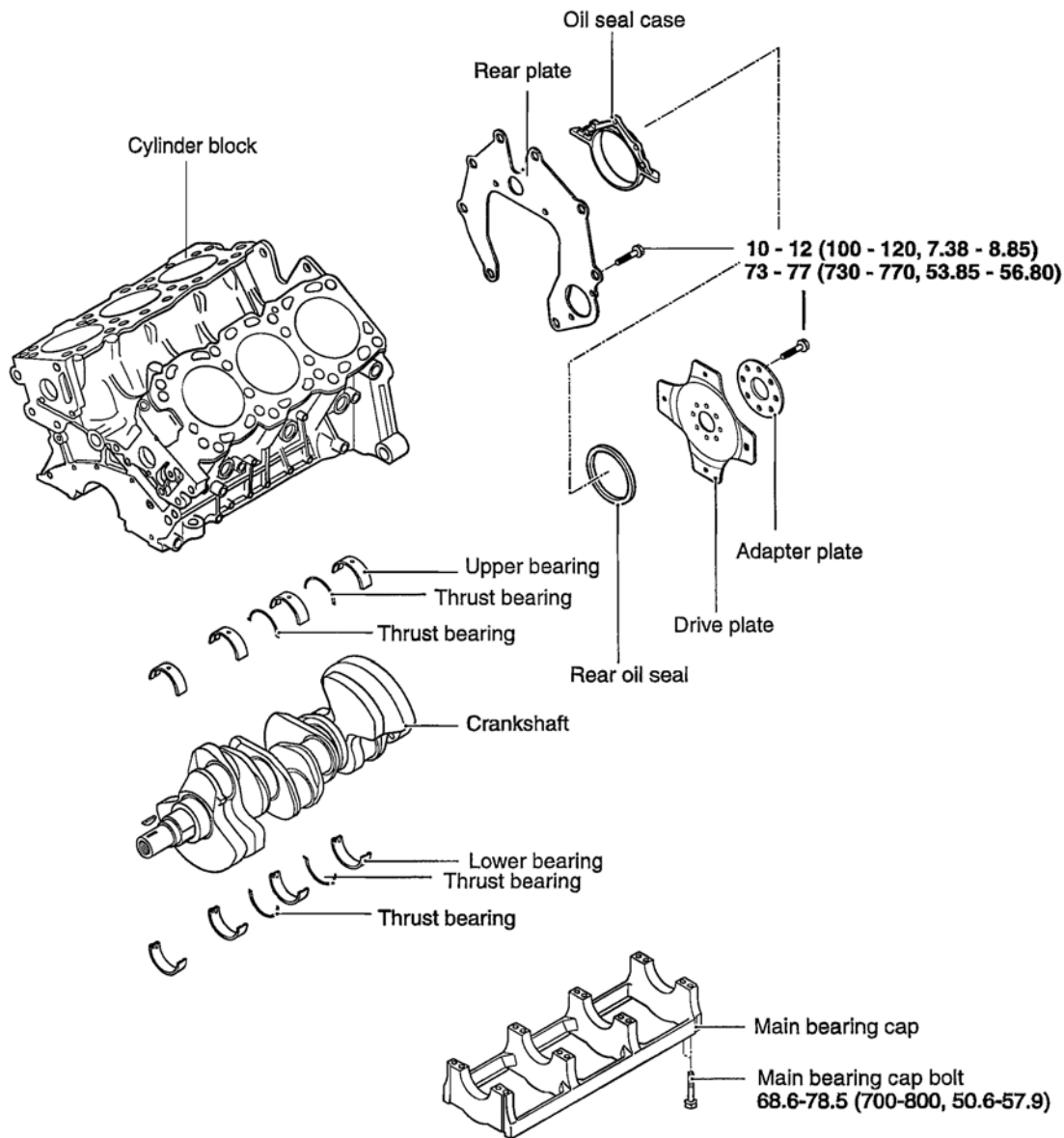

TORQUE : N·m (kg·cm, lb·ft)

G00320573

Fig. 121: Exploded View Of Crankshaft Components
Courtesy of KIA MOTORS AMERICA, INC.

DISASSEMBLY

1. Remove the timing belt, cylinder head assembly, drive plate, transaxle mounting plate oil pan. See **TIMING SYSTEM**.
2. Remove the oil seal case and the rear oil seal.

3. Remove the connecting rod caps.

NOTE: Mark the main bearing caps to reassemble in the original position and direction.

4. Remove the main bearing caps and remove the crankshaft.

Keep the bearings in order by cap number.

INSPECTION

CRANKSHAFT

1. Check the crankshaft journals and pins for damage, uneven wear and cracks. Also check the oil holes for restrictions.

Repair or replace any defective part.

2. Inspect for out-of-roundness and taper of the crankshaft journal and pin.

Crankshaft journal O.D	Crankshaft pin O.D
63.982-64.000mm (2.519-2.520in)	54.982-55.000mm (2.164-2.165 in)

G00320574

Fig. 122: Crankshaft Specification
Courtesy of KIA MOTORS AMERICA, INC.

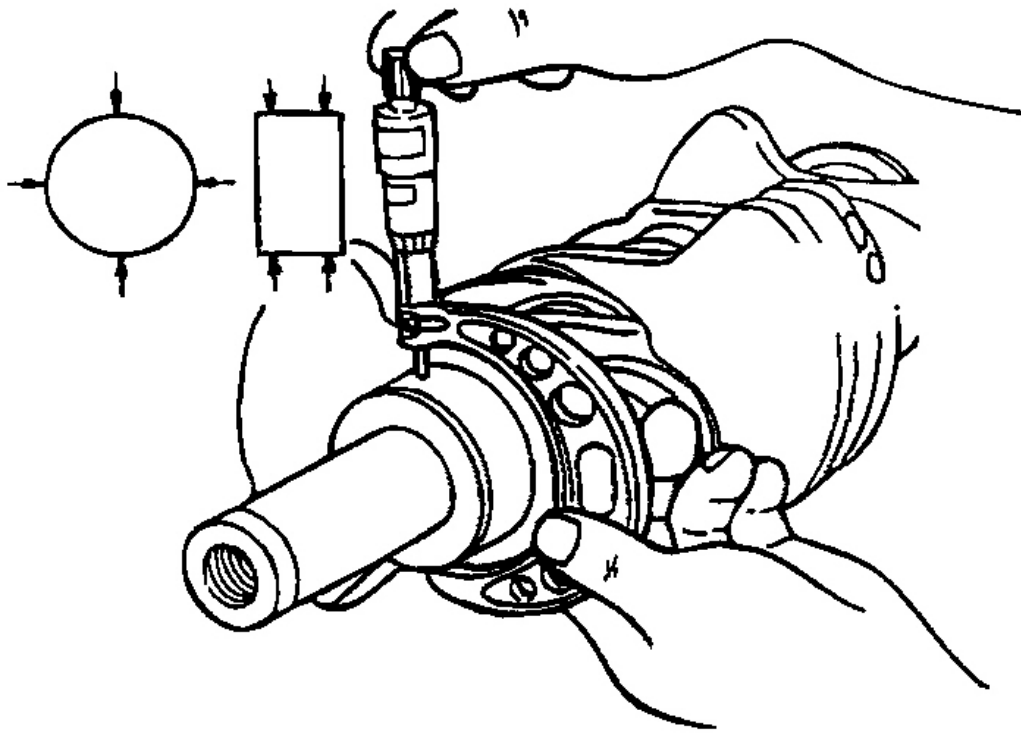

G00320575

Fig. 123: Measuring Crankshaft Journal
Courtesy of KIA MOTORS AMERICA, INC.

MAIN BEARING AND CONNECTING ROD BEARING

Visually inspect each bearing for peeling, melt, seizure and improper contact. Replace any defective bearings.

OIL CLEARANCE MEASUREMENT

Check for oil clearance by measuring the outside diameter of the crankshaft journal and the inside diameter of the bearing. The clearance can be obtained by calculating the difference between the measured outside and inside diameter.

Standard value

Oil clearance

Crankshaft main bearing: 0.018 - 0.036 mm (0.0007 - 0.0014 in)

Connecting rod bearing: 0.022 - 0.040 mm (0.0009 - 0.0016 in)

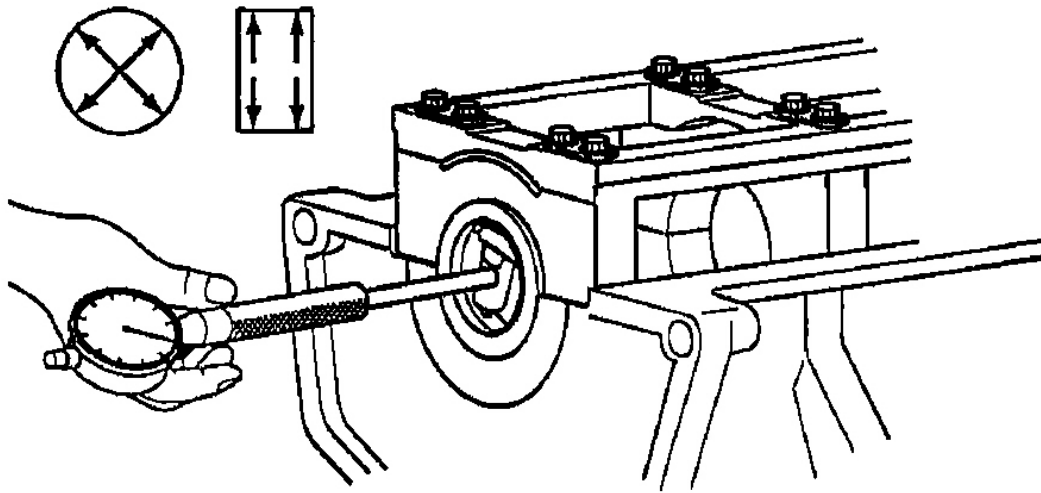

G00320576

Fig. 124: Measuring Oil Clearance
Courtesy of KIA MOTORS AMERICA, INC.

PLASTIGAUGE METHOD

Plastigauge may be used to measure the clearance.

1. Remove oil and grease and any other dirt from the bearings and journals.
2. Cut the plastigauge to the same length as the width of the bearing and place it in parallel with the journal, avoiding the oil holes.

Plastic gauge

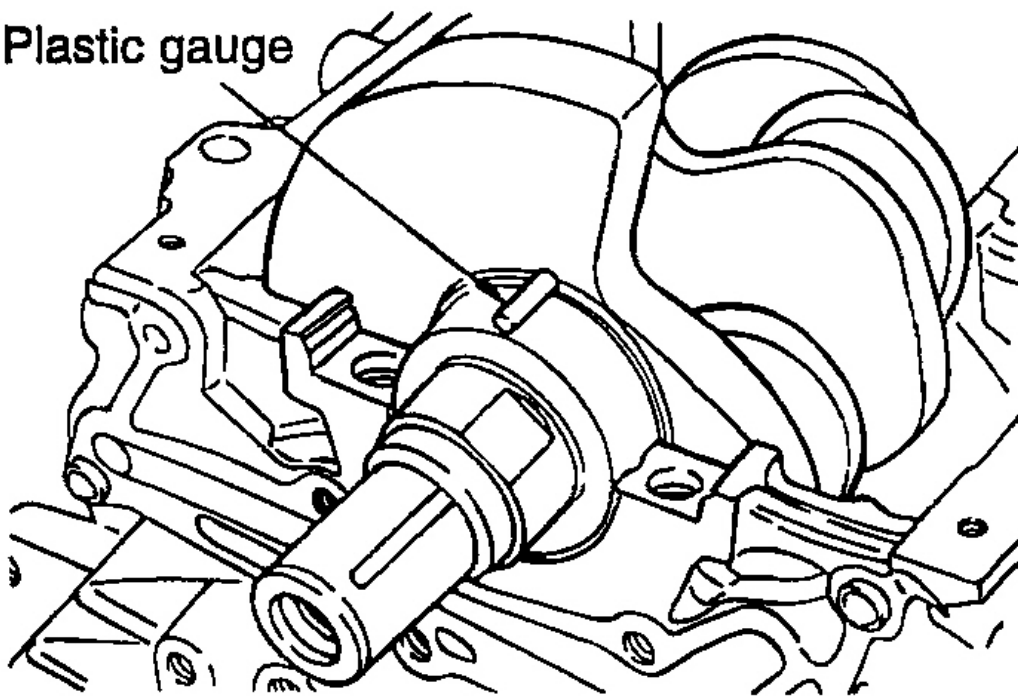

G00320577

Fig. 125: Measuring Oil Clearance Using Plastigauge
Courtesy of KIA MOTORS AMERICA, INC.

3. Install the crankshaft, bearings and caps and tighten them to the specified torques. During this operation, do not turn the crankshaft. Remove the caps. Measure the width of the widest part by using the scale printed on the gauge package.

If the clearance exceeds the repair limit, the bearing should be replaced or an undersize bearing should be used.

When installing a new crankshaft, be sure to use standard size bearings.

Should the standard clearance not be obtained even after bearing replacement, the journal and pin should be ground to undersize and a bearing of the corresponding undersize should be installed.

OIL SEAL

Check the front and rear oil seals for damage or worn surfaces. Replace any seal that is defective.

DRIVING PLATE

Replace the distorted, damaged, or cracked drive plate.

REASSEMBLY

MAIN BEARING

1. Install the grooved main bearing (upper bearing) on the cylinder block side.

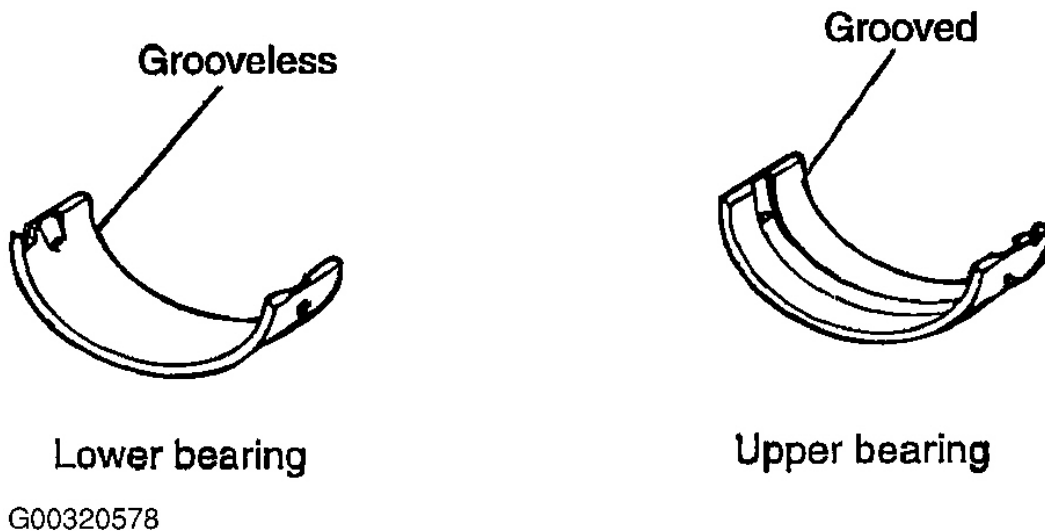
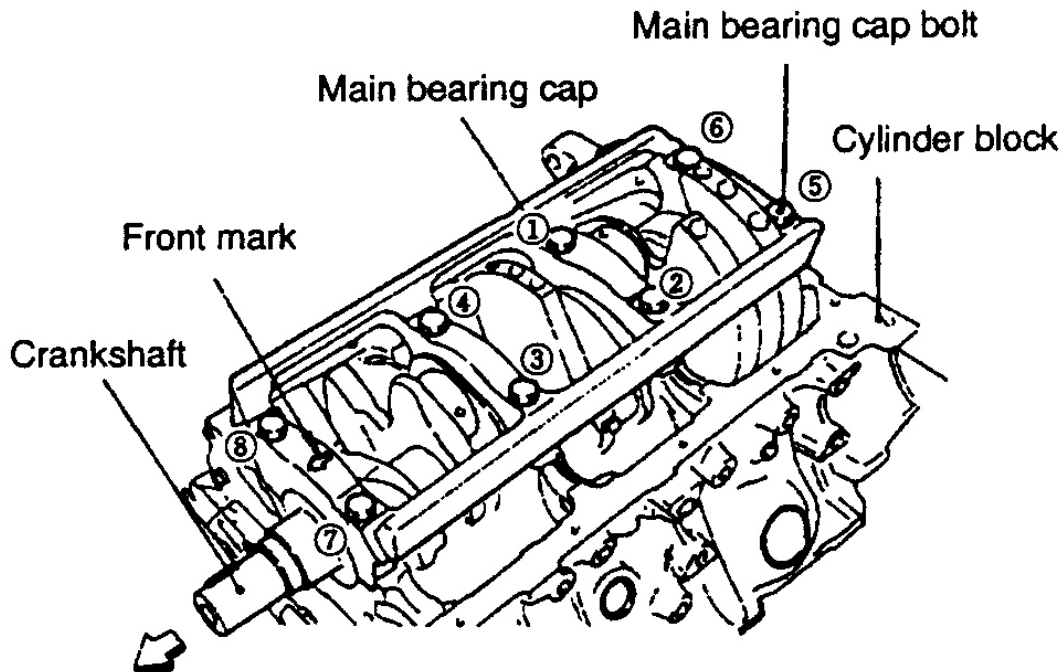

Fig. 126: Identifying Main Bearings
Courtesy of KIA MOTORS AMERICA, INC.

2. Install the grooveless main bearing (lower bearing) on the main bearing cap side.
3. Install the crankshaft. Apply engine oil to the journal and pin.
4. Caps should be installed with the arrow mark directed toward the front of the engine. The cap number sequence must be correct.
5. Tighten all cap bolts to the specified torque according to the order as shown, see **Fig. 127**.

Main bearing cap bolt, tightening torque: 68.6-78.5 N.m (700-800 kg.cm, 50.6-57.9 lb.ft)



G00376818

Fig. 127: Crankshaft Bearing Cap Tightening Sequence
 Courtesy of KIA MOTORS AMERICA, INC.

6. Cap bolt should be tightened to specified torque in 4~5 steps before being tightened to the specified torque.
7. Make certain that the crankshaft turns freely and has the proper crankshaft end play.

Crankshaft end play, standard value: 0.050-0.250 mm (0.00197-0.0098 in)

Limit: 0.35mm (0.014 in)

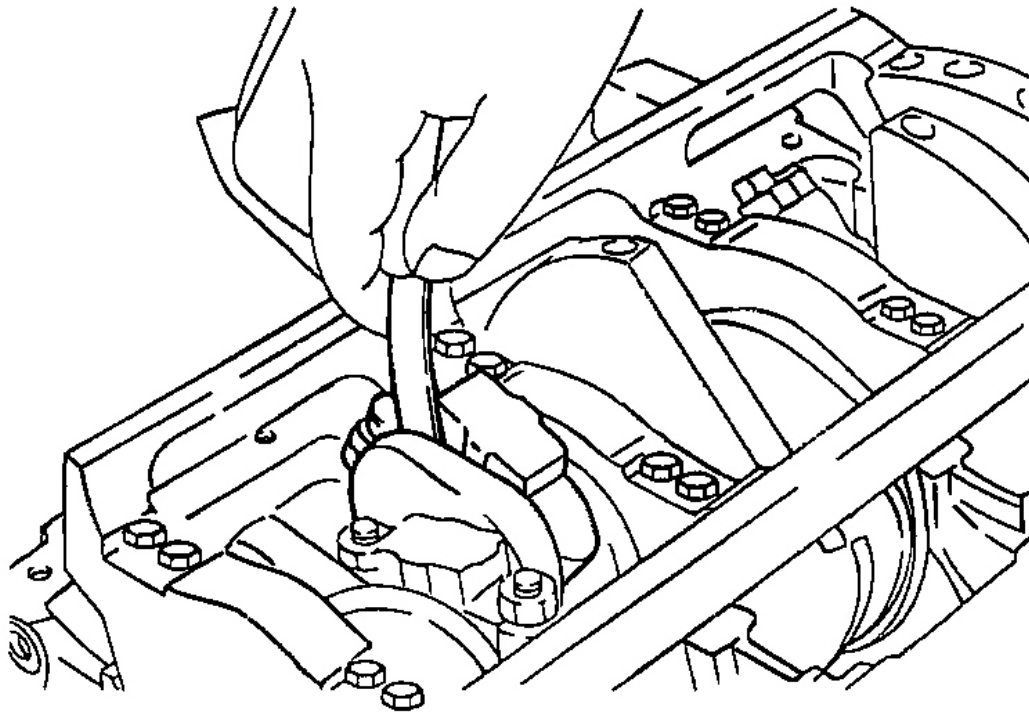

G00320579

Fig. 128: Measuring Crankshaft End Play
Courtesy of KIA MOTORS AMERICA, INC.

8. Assemble the rear oil seal to oil case using the special tool (09231-33000).

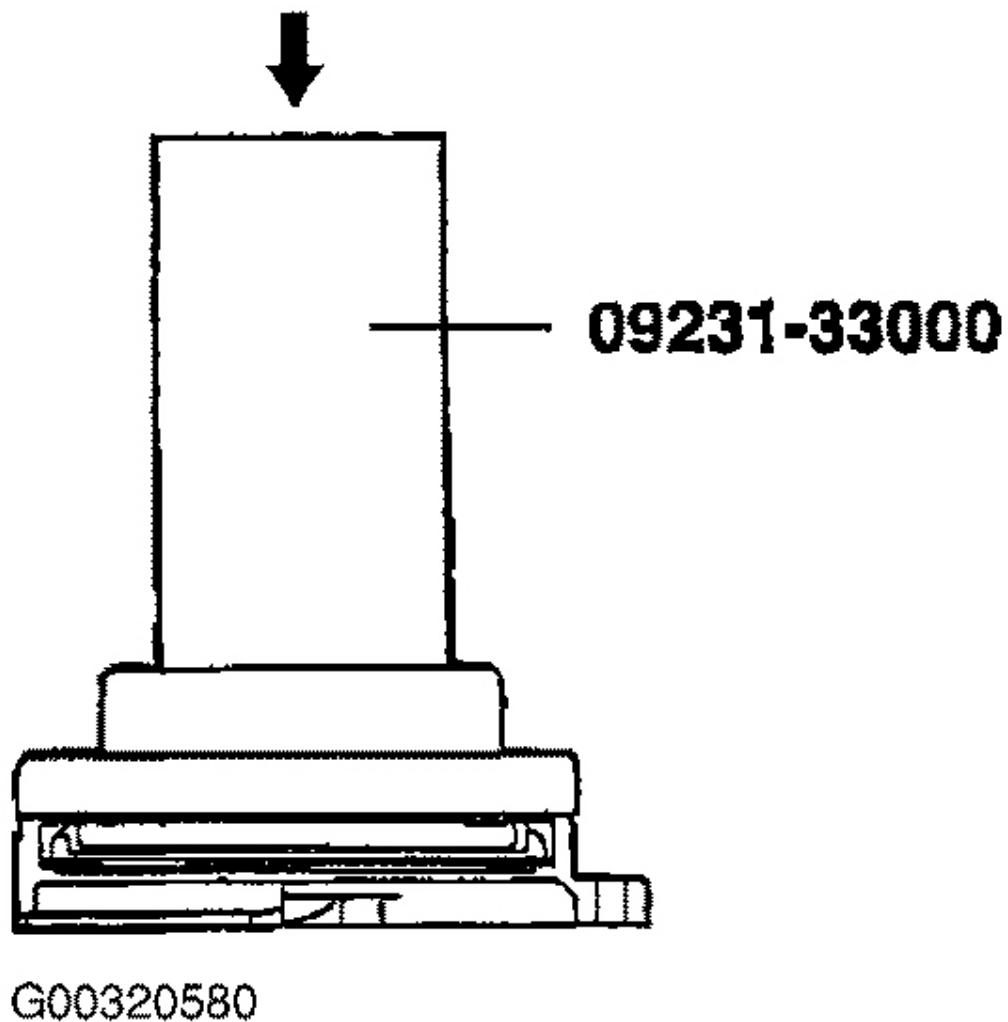
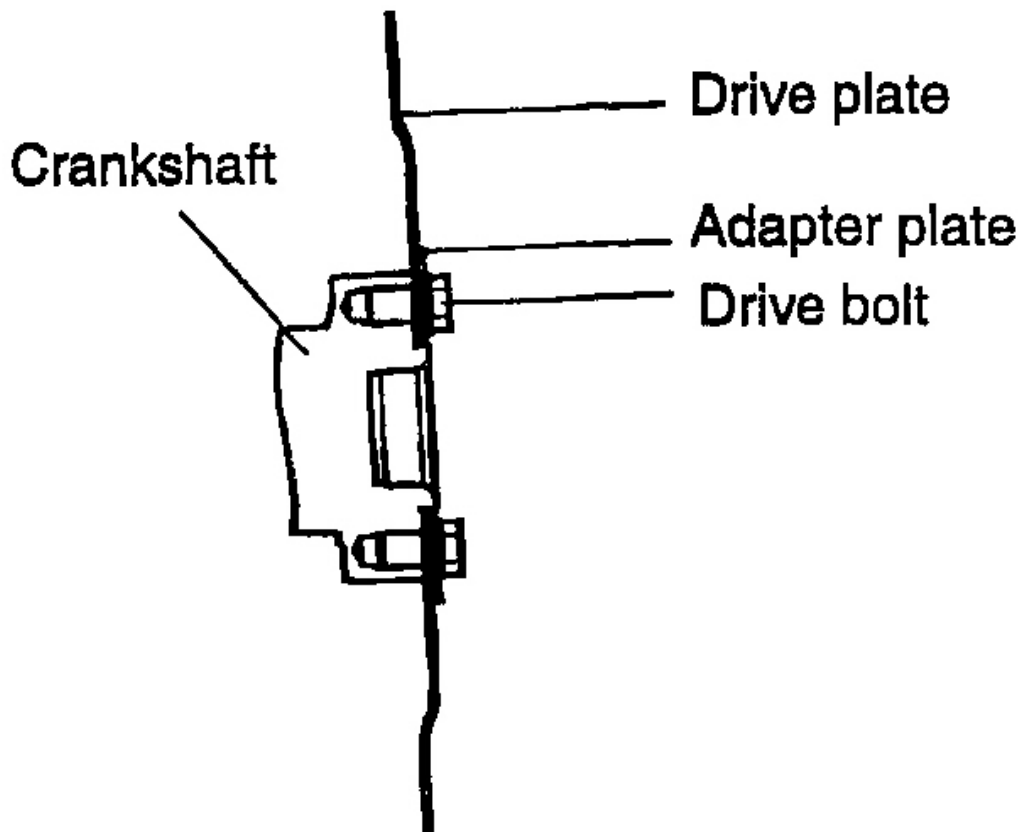

Fig. 129: Positioning Rear Oil Seal Onto Special Tool
Courtesy of KIA MOTORS AMERICA, INC.

9. Install the drive plate and the adapter plate.

Tightening torque

Drive bolt: 73 - 77 N.m (730 - 770 kg.cm, 53.85 - 56.80 lb.ft)



G00320582

Fig. 130: Installing Drive & Adapter Plates
Courtesy of KIA MOTORS AMERICA, INC.

ENGINE BLOCK

COMPONENTS

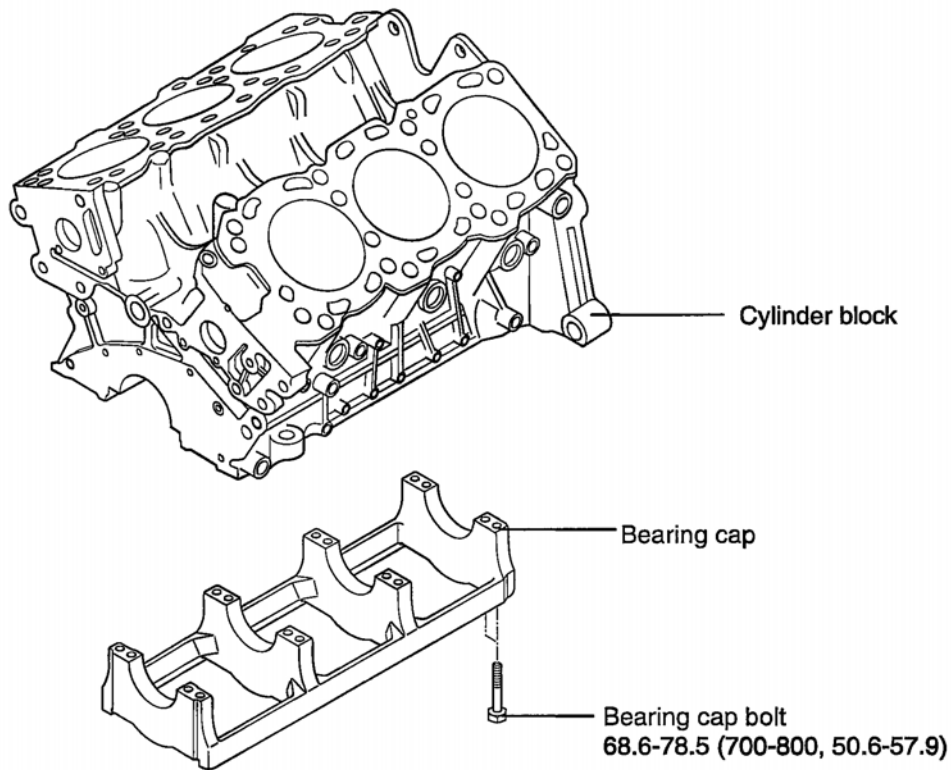

TORQUE : N·m (kg·cm, lb·ft)

G00320524

Fig. 131: Identifying Cylinder Block Components
Courtesy of KIA MOTORS AMERICA, INC.

DISASSEMBLY

Remove the timing belt, cylinder head assembly, drive plate, transaxle mounting plate, oil pan and the oil pump case.

INSPECTING CYLINDER BLOCK

1. Visually check the cylinder block for scores, rust and corrosion.

Also check for cracks or any other defects using a proper tool. Repair or replace the block if defective.

2. Measure the cylinder bore with a cylinder gauge at the three levels indicated in the directions of A and B, see **Fig. 132**.

Level 1: No. 1 piston ring position with piston at TDC.

Level 2: Center of cylinder

Level 3: Bottom of cylinder

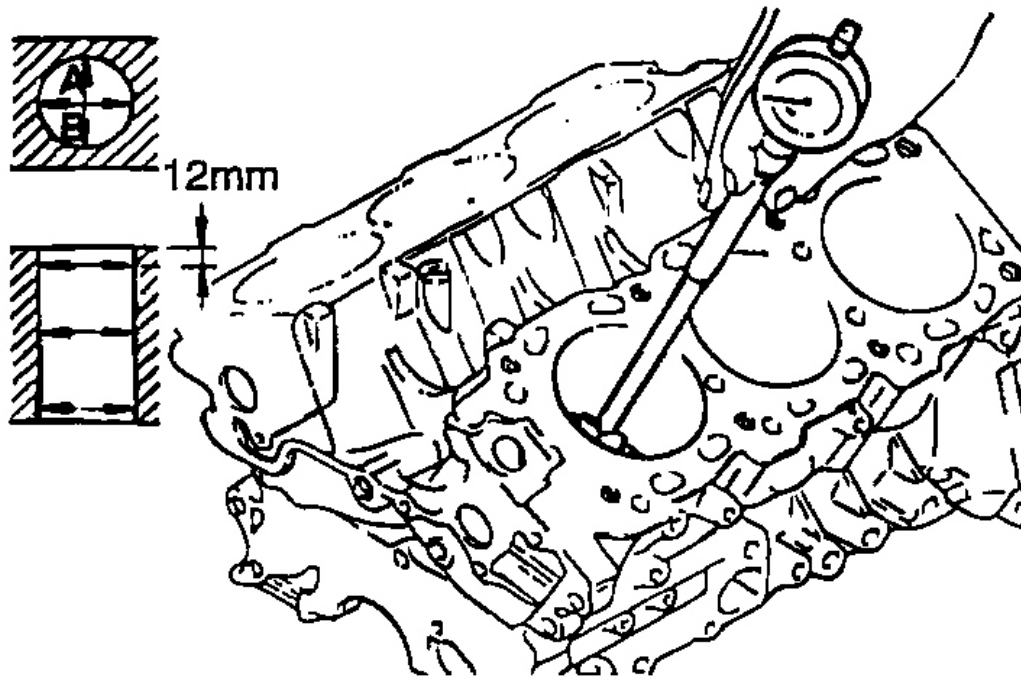

G00320525

Fig. 132: Measuring Cylinder Bore

Courtesy of KIA MOTORS AMERICA, INC.

3. If the cylinder bores show more than the specified out-of round or taper, or if the cylinder walls are badly scuffed or scored, the cylinder block should be rebored and honed. New oversize pistons and rings should be installed.

Standard value

Cylinder bore: 93.00-93.03 mm (3.66-3.663 in)

Deviation of concentricity and taper of cylinder bore : 0.02 mm (0.00079 in) or less

4. If a ridge exists at the top of the cylinder, cut it way with a ridge reamer.
5. Oversize pistons are available in four sizes.

Oversize piston size.

0.25 O.S.: 0.25 mm (0.01 in)

0.50 O.S.: 0.50 mm (0.02 in)

0.75 O.S.: 0.75 mm (0.03 in.)

1.00 O.S.: 1.00 mm (0.039 in.)

6. To rebore the cylinder to oversize, keep the specified clearance between the oversize piston and the bore, and make sure that all pistons used are of the same oversize. When measuring the piston outside diameter measure the section of the thrust surface at 10 mm (0.39 in) above the bottom of the piston skirt.

Clearance between piston and cylinder wall: 0.03-0.05 mm (0.001-0.002 in)

7. Check the flatness of the upper surface. If the top surface exceeds limits, grind it to a minimum limit value or replace. (Measuring method is same as that of cylinder head flatness.)

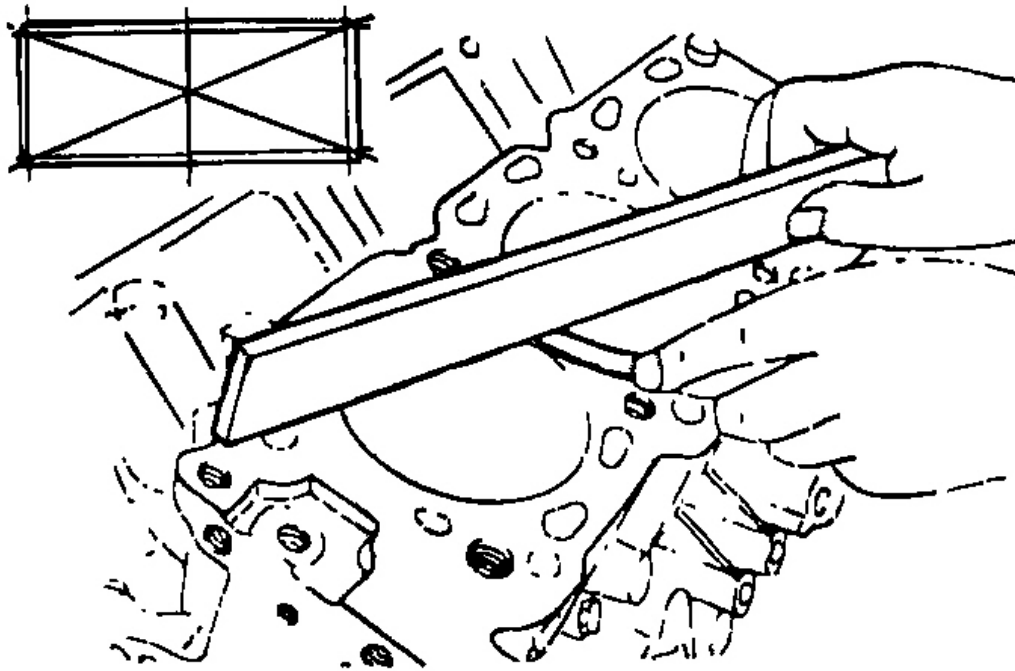

G00320526

Fig. 133: Measuring Cylinder Block Flatness
 Courtesy of KIA MOTORS AMERICA, INC.

Standard value:

Flatness of the gasket mating surface: less than 0.05 mm (0.002 in)

Limit Flatness of the gasket mating surface: 0.1 mm (0.0039 in)

CAUTION: When the cylinder head is assembled, grinding less than 0.2 mm is permissible. Grind the gasket surface of the cylinder block less than 0.2 mm.

BORING CYLINDER

1. Oversize pistons used should be determined on the basis of the largest bore cylinder.

PISTON MARK & LIMIT

Mark	Limit Standard In. (mm)

OS 25		0.25 mm
OS 50		0.50 mm
OS 75		0.75 mm
OS 100		0.100 mm

NOTE: Size mark is stamped on top of the piston.

2. Measure the outside diameter of the piston to be used.

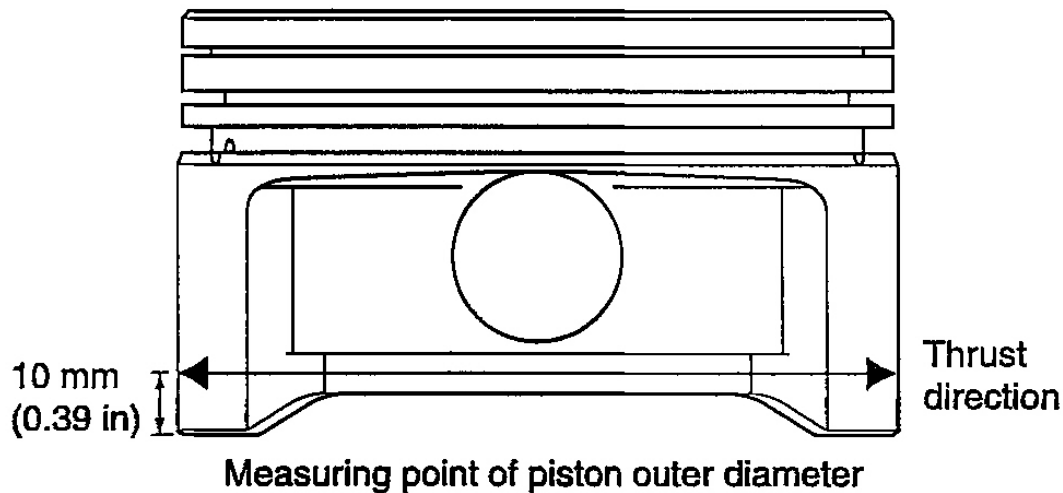

G00320528

Fig. 134: Measuring Piston Diameter
 Courtesy of KIA MOTORS AMERICA, INC.

3. Based on the measured O.D., calculate the boring finish dimension.

Boring finish dimension = piston outer diameter + 0.02~0.04 mm (The clearance between piston outer diameter and cylinder) - 0.01 mm (Honing margin)

4. Bore each of the cylinders to the calculated size.

CAUTION: To prevent distortion that may result from temperature rise during honing, bore the cylinder holes in the firing order sequence.

- 5.hone the cylinders, finishing them to the proper dimension (piston outside diameter + gap with cylinder).
6. Check the clearance between the piston and cylinder.

Standard value: 0.03-0.05 mm (0.0012 - 0.0020 in)

NOTE:

- All cylinders should be bored to the same oversize.
- Never bore only one cylinder to an oversize.

COOLING SYSTEM

GENERAL

INLET CONTROL

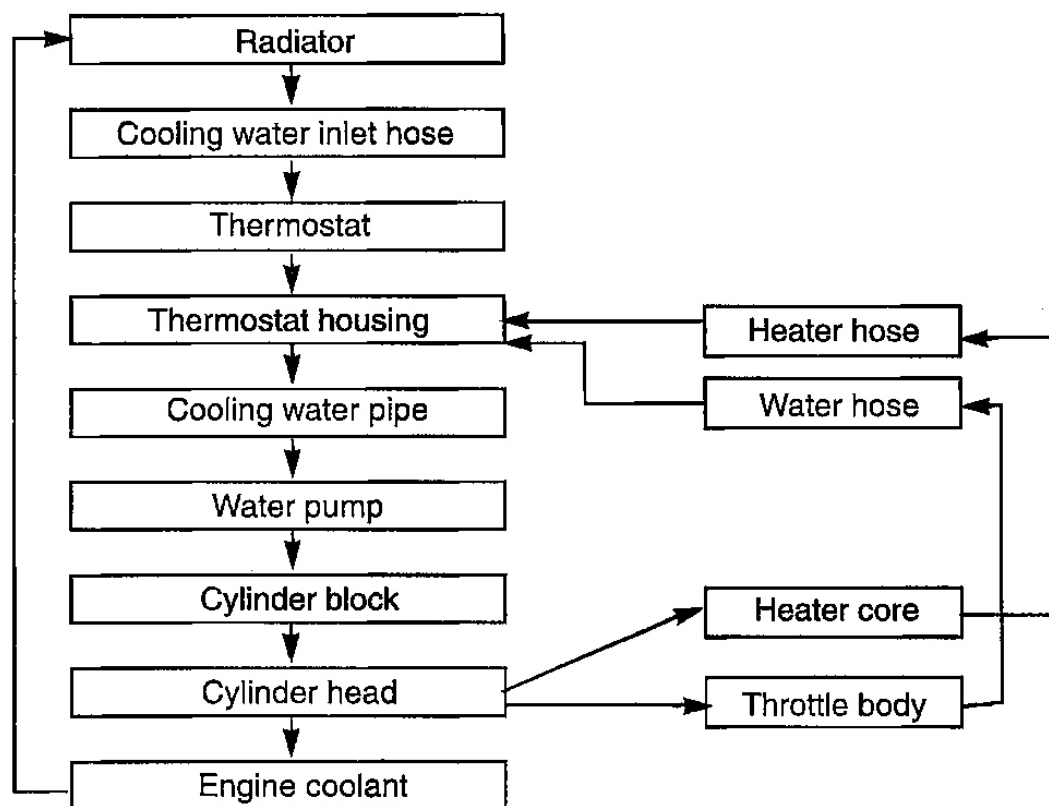

G00320589

Fig. 135: Illustrating Coolant Inlet Flow
Courtesy of KIA MOTORS AMERICA, INC.

FLOW CHART

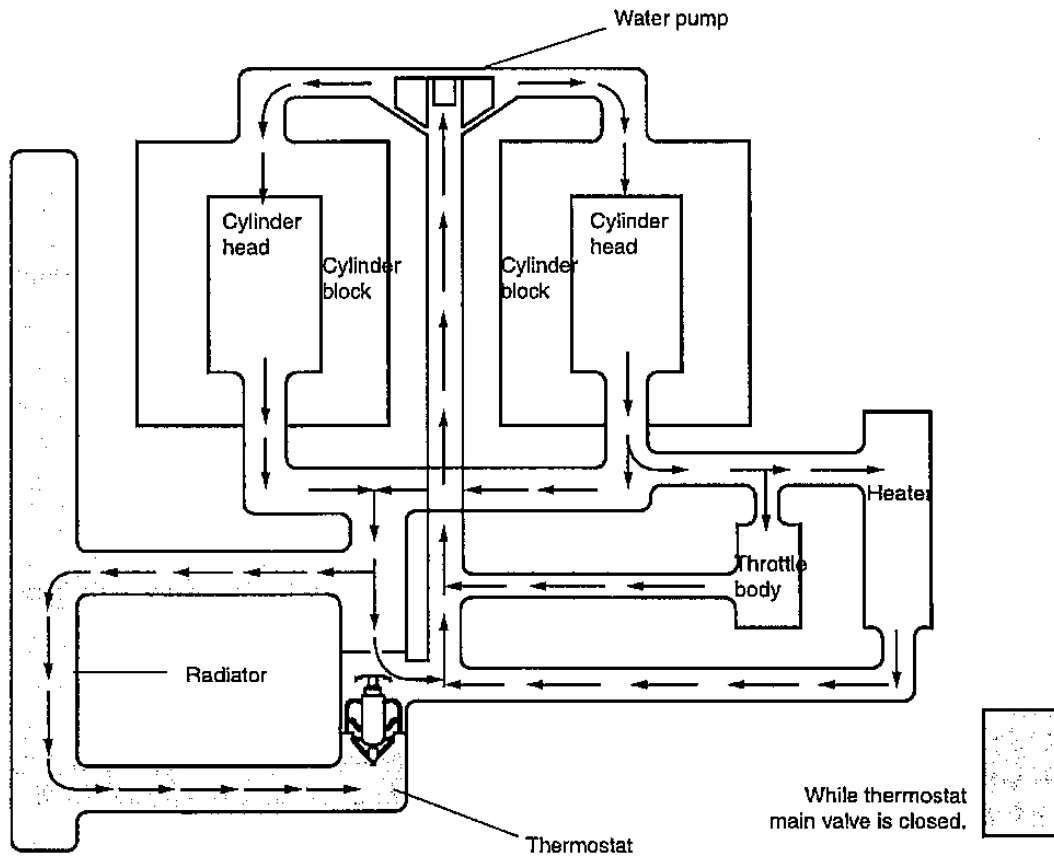

G00320590

Fig. 136: Illustrating Coolant Flow Chart
 Courtesy of KIA MOTORS AMERICA, INC.

RADIATOR

COMPONENTS

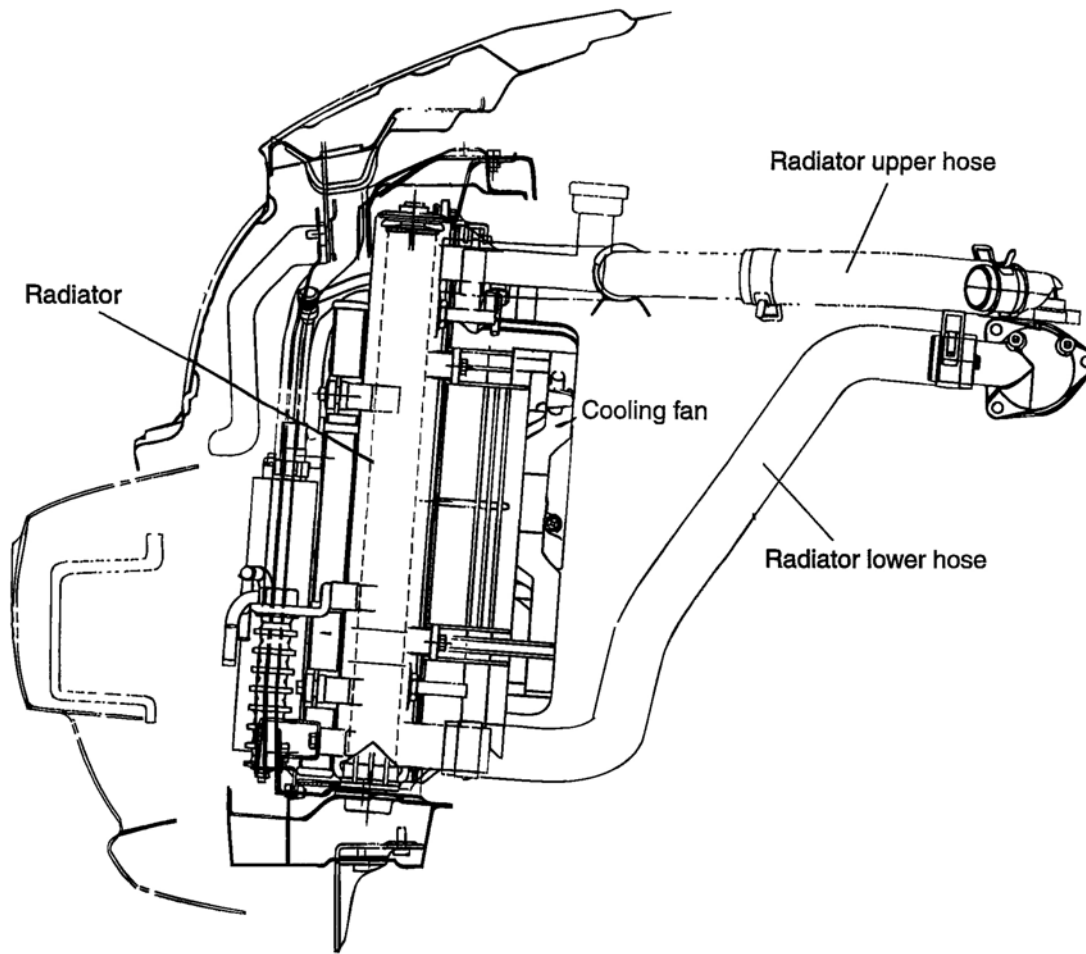

G00320611

Fig. 137: Locating Radiator Components
Courtesy of KIA MOTORS AMERICA, INC.

REMOVAL

1. Remove the air duct.
2. Remove the hood locker.
3. Disconnect the horn connector.
4. Remove the shroud upper member.
5. Disconnect the radiator fan motor connector and the condenser fan motor connector.
6. Remove the radiator fan and the condenser fan.
7. After marking on the radiator hose and clamp, disconnect the upper, lower hose and over flow hose.
8. Remove the radiator.

INSPECTION

1. Check if there are foreign objects among radiator fins.
2. Inspect the radiator fins for damage, if necessary, straighten them up.
3. Inspect the radiator for corrosion, damage and rust.
4. Inspect the radiator for crack, damage and any weakened part.

INSTALLATION

1. Fill the radiator reservoir tank with new coolant.
2. Run the engine till coolant temperature increases to open thermostat valve, and then stop the engine.
3. Remove the radiator cap and fill the radiator with water up to the filler neck, and fill the reservoir tank up to the specified level.
4. Check if there are any leakage from radiator, hose and connecting part.

RADIATOR CAP

COMPONENTS

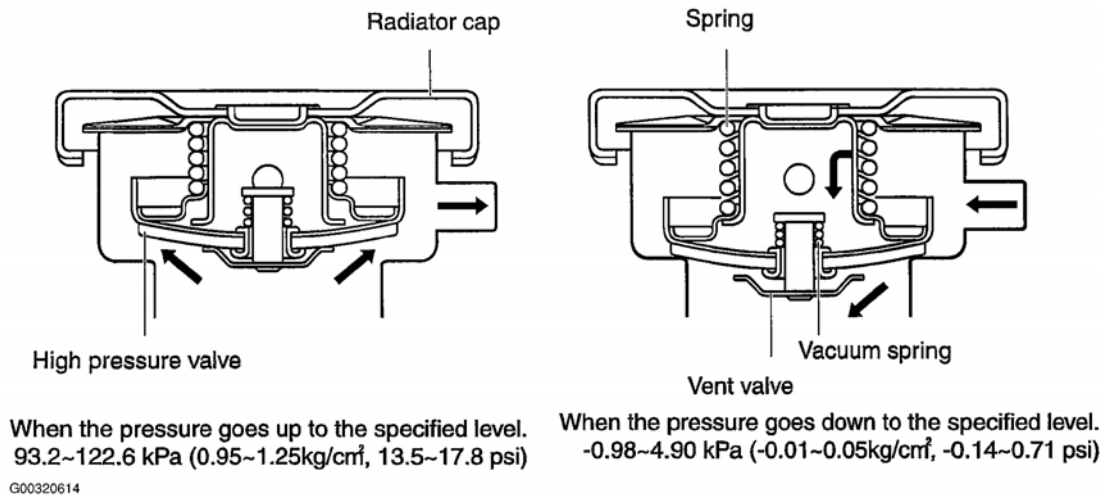
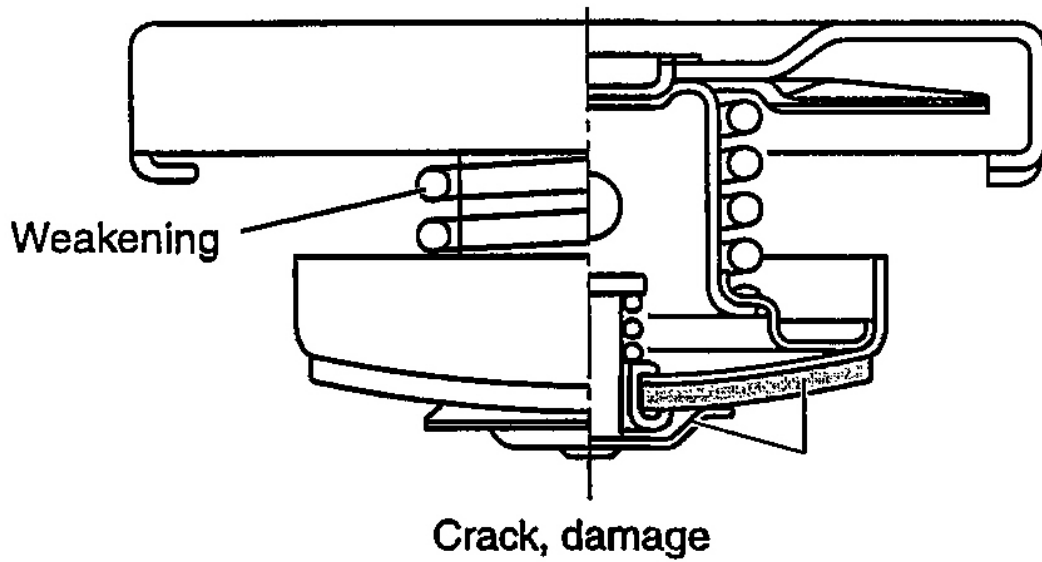

Fig. 138: Illustrating Radiator Cap Components
 Courtesy of KIA MOTORS AMERICA, INC.

INSPECTION

1. Inspect the radiator cap for damage, crack and weakening.



G00320615

Fig. 139: Inspecting Radiator Cap
Courtesy of KIA MOTORS AMERICA, INC.

2. Connect the radiator cap tester to the radiator cap.
3. Apply the pressure to the tester until the needle is fixed.

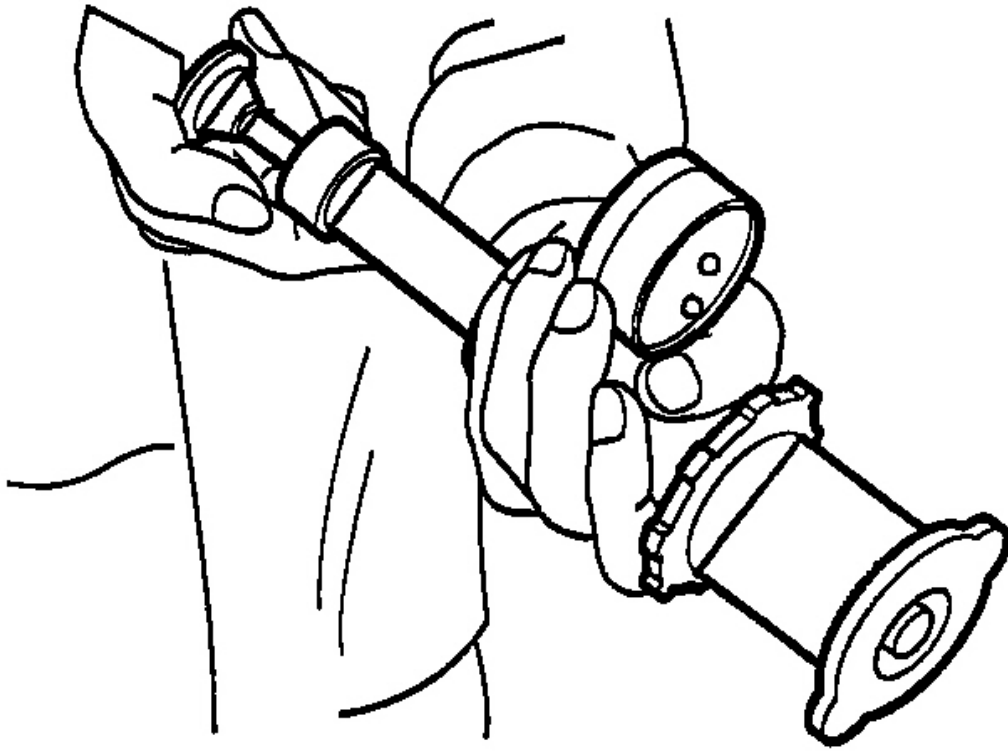

G00320616

Fig. 140: Testing Radiator Cap
Courtesy of KIA MOTORS AMERICA, INC.

4. If the needle stays at the same position for 10 seconds, the radiator cap is in good condition.

RADIATOR FAN MOTOR

COMPONENTS

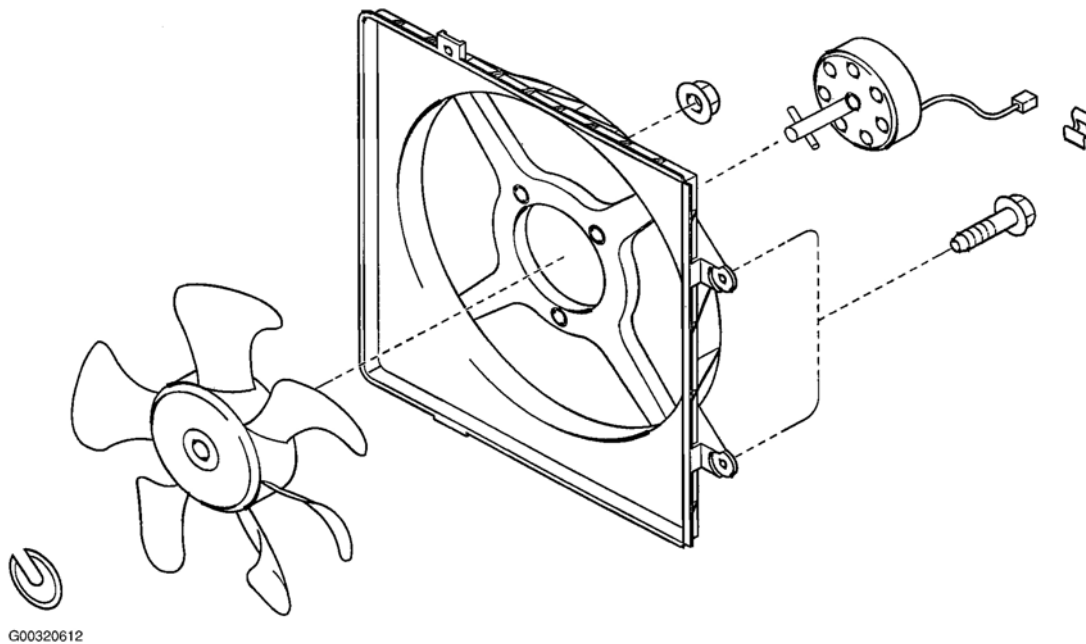

Fig. 141: Exploded View Of Fan Motor Assembly
Courtesy of KIA MOTORS AMERICA, INC.

REMOVAL

1. Remove the air duct.
2. Remove the hood locker.
3. Disconnect the horn connector.
4. Remove the shroud upper member.
5. Disconnect the radiator fan motor connector.
6. Remove the radiator fan.

INSPECTION

1. Radiator fan motor
 - a. Check if the radiator fan is rotating when the battery voltage is supplied to both terminals as shown in the figure.

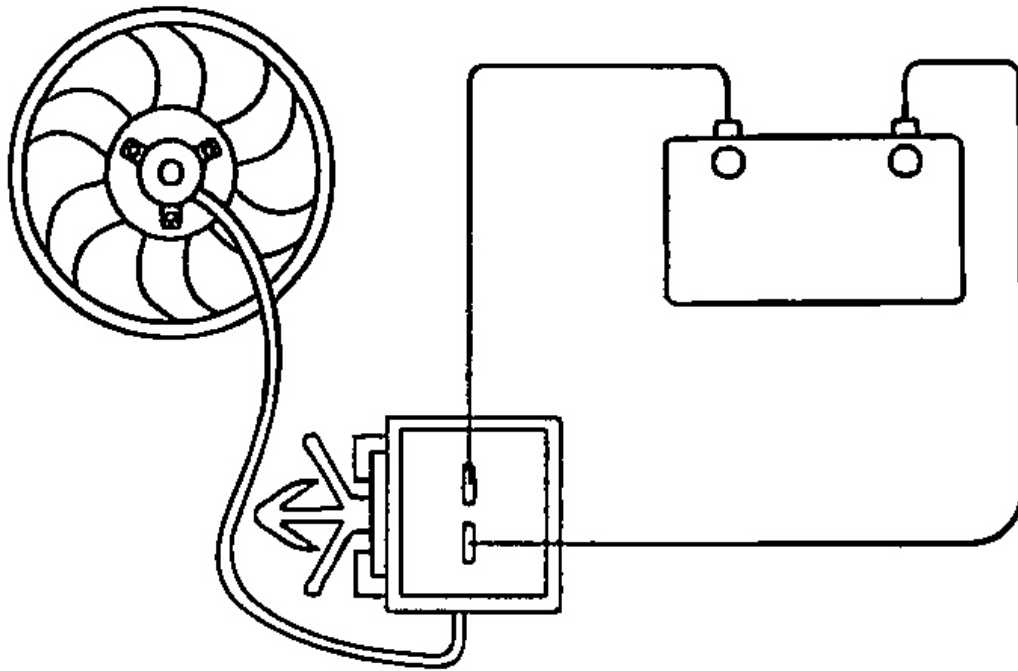

G00320613

Fig. 142: Testing Radiator Fan Motor
Courtesy of KIA MOTORS AMERICA, INC.

- b. Check if there is abnormal noise while motor is rotating.

INSTALLATION

1. Installation is done in the reverse order of disassembly procedure.

CAUTION:

- When assembling the shroud, be cautious not to touch the cooling fan.
- After installing, while the fan is operating, check if there is abnormal noise and vibration.

ENGINE WATER PUMP

COMPONENTS

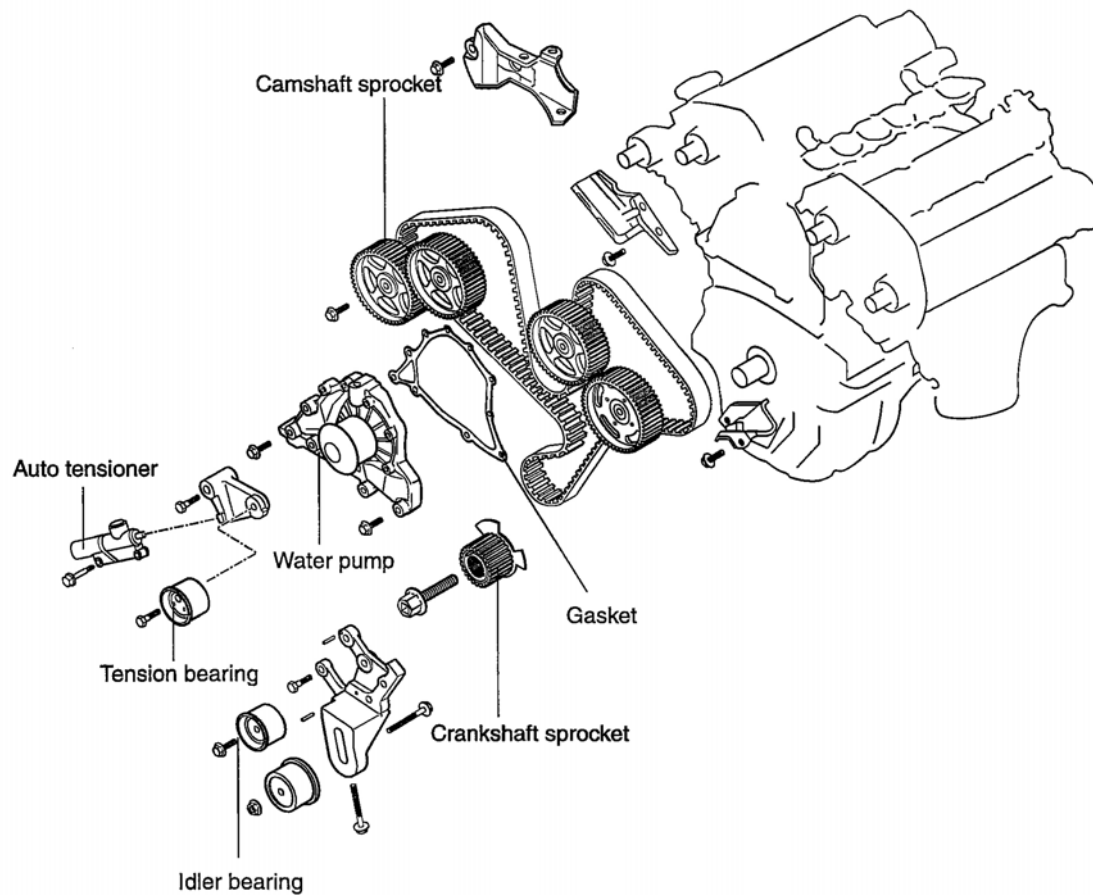

G00320609

Fig. 143: Exploded View Of Water Pump Assembly
 Courtesy of KIA MOTORS AMERICA, INC.

INSTALLATION

1. Clean the gasket mating surface of the water pump body and cylinder block.
2. After installing new O-ring in the groove at front of the water pipe, soak it with water. At this time, do not soak it with oil or grease.
3. After installing a new water pump gasket and water pump assembly, tighten it to the specified torque, see **Fig. 144**.

Tightening torque:

(A) 5EA:14.7-21.6 N.m (150-220 kg.cm, 10.8-15.9 lb.ft)

(B) 1EA:32.4-49.0 N.m (330-500 kg.cm, 23.9-36.2 lb.ft)

(C) 2EA:19.6-26.5 N.m (200-270 kg.cm, 14.5-19.5 lb.ft)

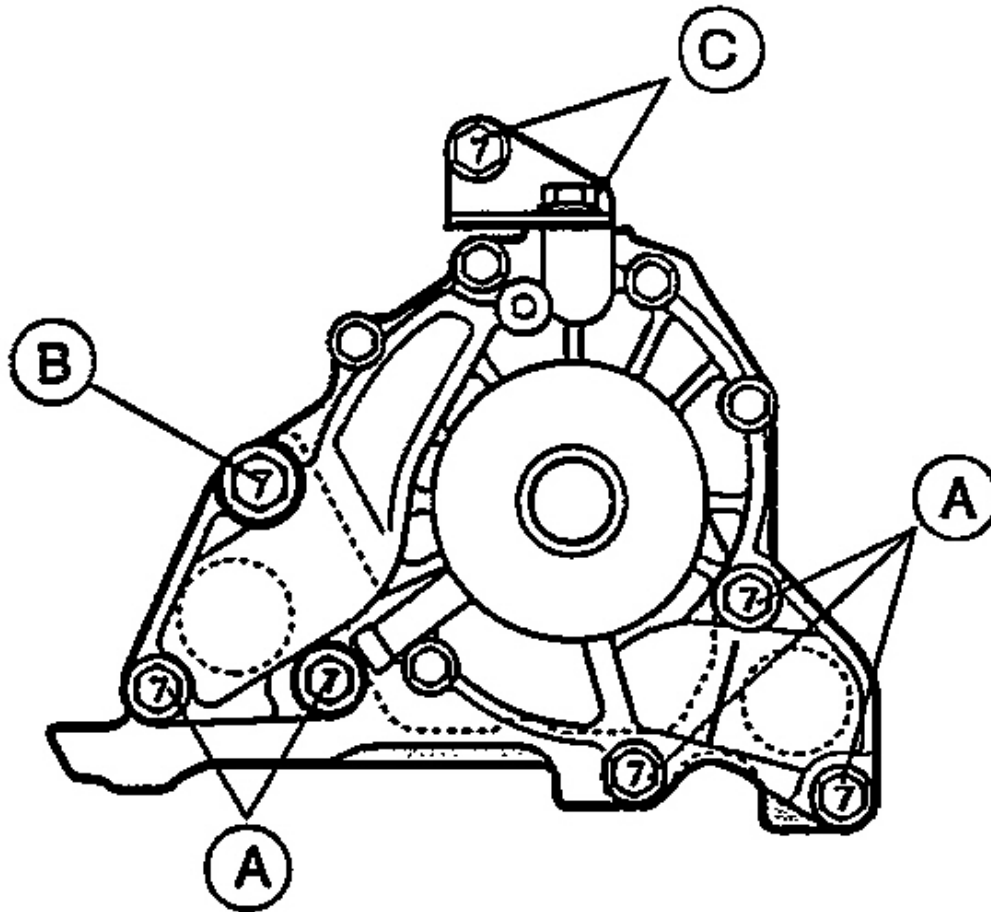

G00320610

Fig. 144: Water Pump Tightening Sequence
Courtesy of KIA MOTORS AMERICA, INC.

4. Install the timing belt tensioner and timing belt. After adjusting the timing belt tension, install the timing belt cover.
5. After installing the water pump pulley and driving belt, adjust the belt tension.
6. Refill it with coolant.
7. Check for leakage by running the engine.

THERMOSTAT

COMPONENTS

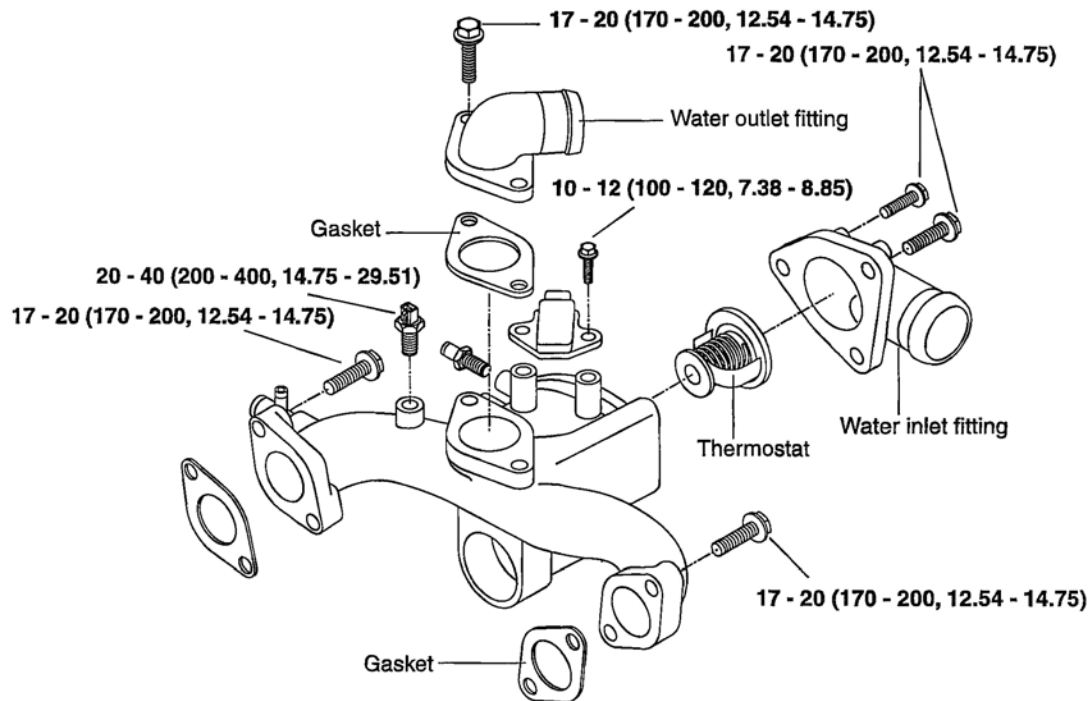

TORQUE : N·m(kg·cm, lb·ft)

G00320617

Fig. 145: Exploded View Of Thermostat Components
Courtesy of KIA MOTORS AMERICA, INC.

REMOVAL

1. Drain the coolant to the bottom level of thermostat.
2. Remove the water outlet fitting.
3. Remove the thermostat.

INSPECTION

1. Heat the thermostat and check if the valve operates properly.

2. Check to determine the temperature at which the valve begins to open and is completely opened.

Valve opening temperature: 80.0-84.0°C (176-183.2°F)

The temperature when the valve is completely opened: 95°C (203°F)

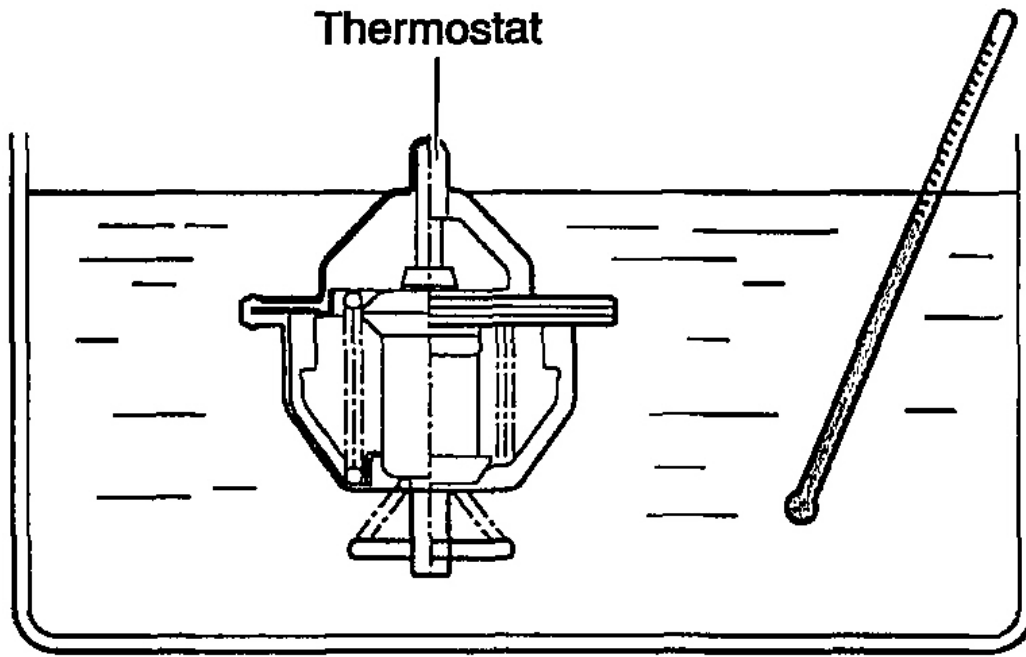

G00320618

Fig. 146: Testing Thermostat

Courtesy of KIA MOTORS AMERICA, INC.

INSTALLATION

1. Align the arrangement mark of thermostat housing with the jiggle valve.

Jiggle valve

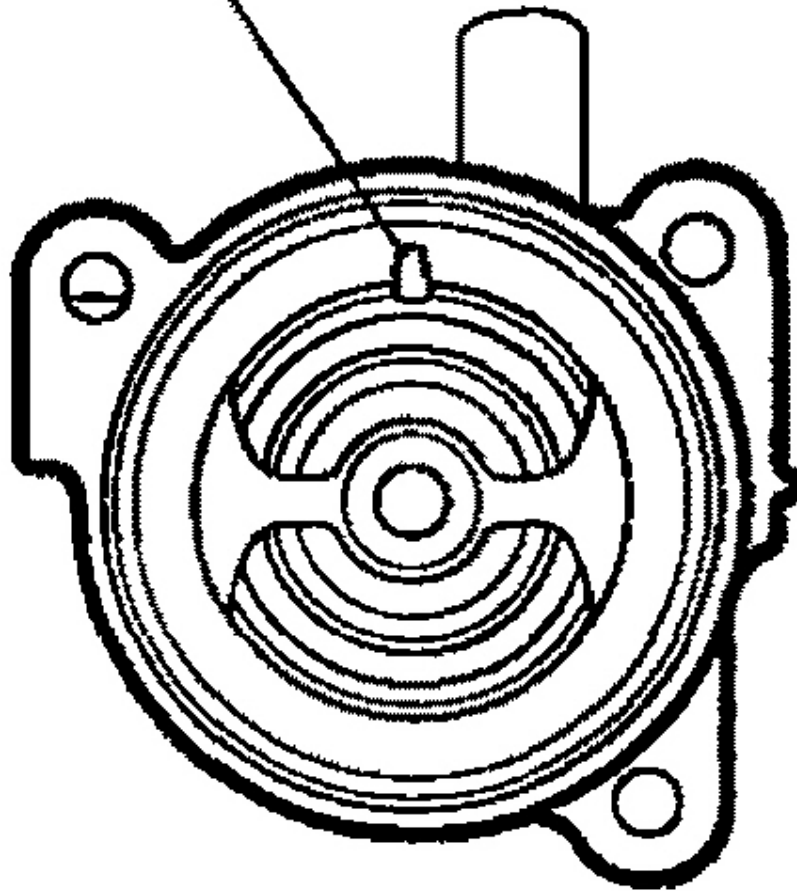

G00320619

Fig. 147: Positioning Thermostat
Courtesy of KIA MOTORS AMERICA, INC.

2. Check to ensure that the flange of the thermostat is correctly seated in the socket of the thermostat housing. If the thermostat is installed in the wrong direction, the bottom of the thermostat will touch the rib inside the intake manifold, making it impossible to seat flange in position.
3. Install a new gasket and engine coolant outlet fitting.

Engine coolant outlet fitting bolt, tightening torque: 17-20 N.m (170-200 kg.m, (12.54-14.75 lb.ft)

4. Refill the coolant.

ENGINE WATER HOSE/PIPES

COMPONENTS

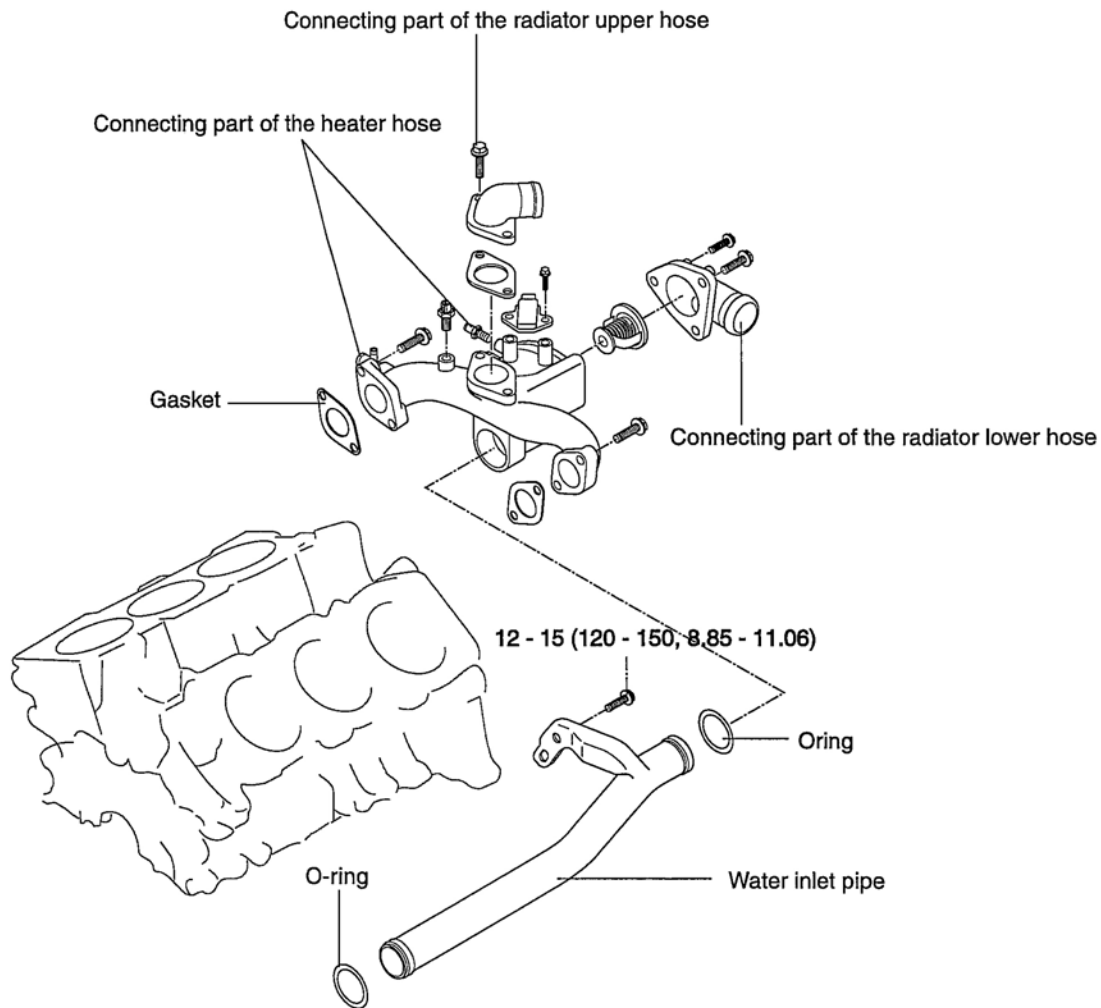

TORQUE : N·m(kg·cm, lb·ft)

G00320602

Fig. 148: Exploded View Of Water Hoses
 Courtesy of KIA MOTORS AMERICA, INC.

REMOVAL

WATER TEMPERATURE GAUGE UNIT AND SENSOR

1. Drain the coolant to the bottom level of the gauge unit.
2. After disconnecting the battery ground cable, disconnect engine harness.
3. Remove the water temperature gauge unit and sensor.

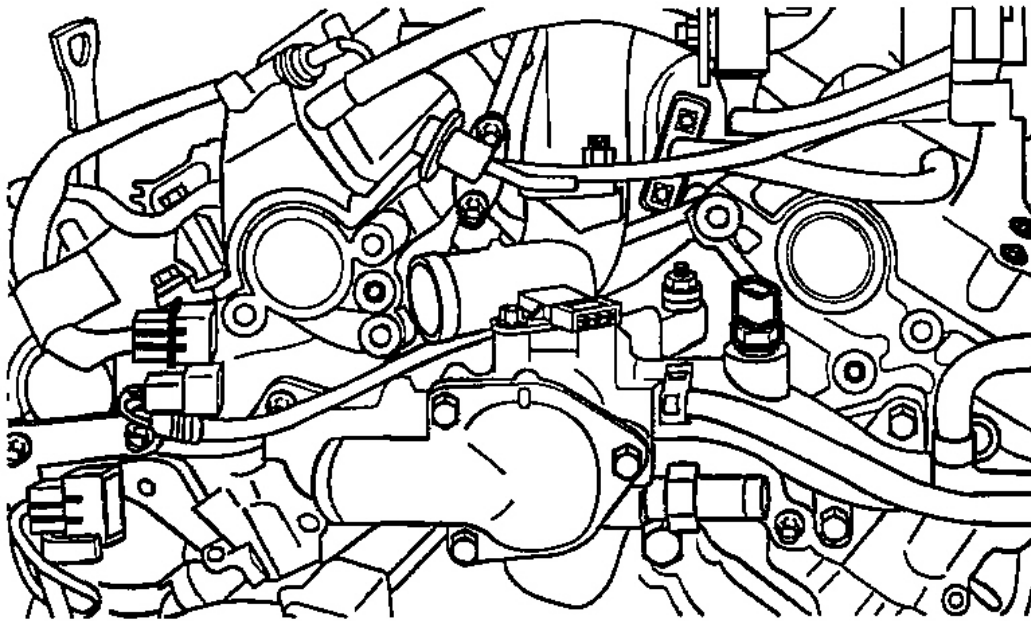

G00320603

Fig. 149: Locating Water Temp Gauge Unit
Courtesy of KIA MOTORS AMERICA, INC.

INSPECTION

ENGINE COOLANT HOSE/PIPES

Check for cracks, damage, or blockage on the water hose and pipe, and replace if necessary.

WATER TEMPERATURE GAUGE UNIT AND SENSOR

1. Water temperature gauge unit
 - a. Heat up the water temperature gauge by immersing it in hot water.
 - b. Check if the resistance is within the specified range.

Specified Value	60°C (140°F)	125Ω	Coil type
	85°C (185°F)	8.4±5.8Ω	
	110°C (230°F)	24 ^{+2.2} _{-1.9} Ω	
	125°C (257°F)	15.2Ω	

G00320604

Fig. 150: Temperature Gauge Resistance Chart
 Courtesy of KIA MOTORS AMERICA, INC.

2. Water temperature sensor
 - a. Immerse the sensor in hot water.
 - b. Check if the resistance is within the specified range.

Specified value	20°C(68°F)	2.45±0.14kΩ
	80°C(176°F)	0.322kΩ

G00320605

Fig. 151: Temperature Sender Resistance Chart
 Courtesy of KIA MOTORS AMERICA, INC.

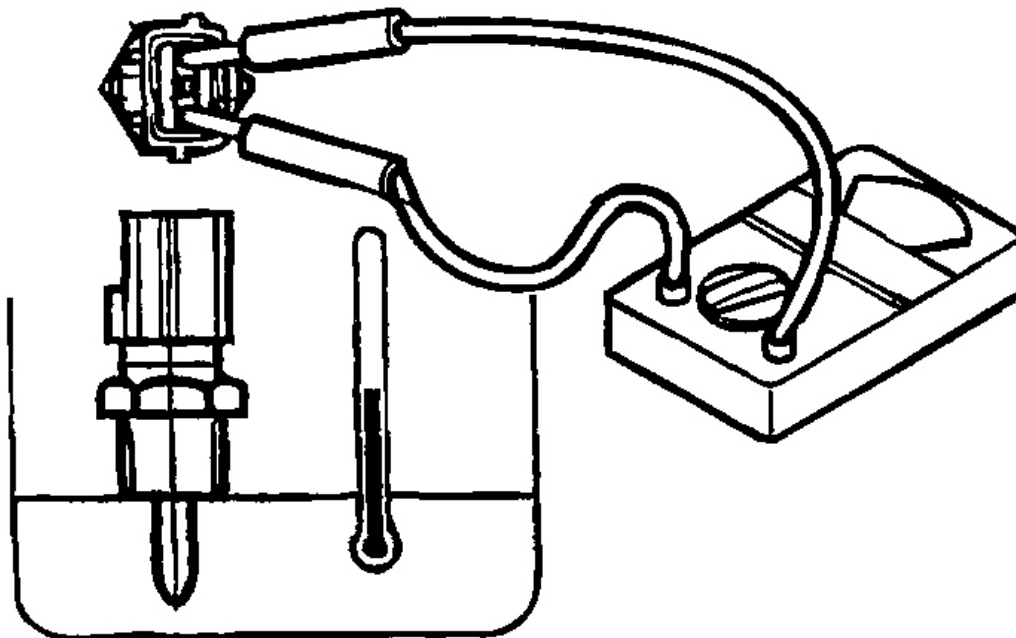

G00320606

Fig. 152: Testing Sending Unit

Courtesy of KIA MOTORS AMERICA, INC.

INSTALLATION

ENGINE COOLANT HOSE/PIPES

After inserting O-ring into a groove at the lower part of water inlet pipe, soak O-ring in water and insert it into the water inlet pipe.

CAUTION:

- Be careful not to smear oil or grease on the water pipe O-ring.
- Pay attention not to let a foreign object get into the connecting part of the water pipe.
- Insert the water pipe up to its end part.

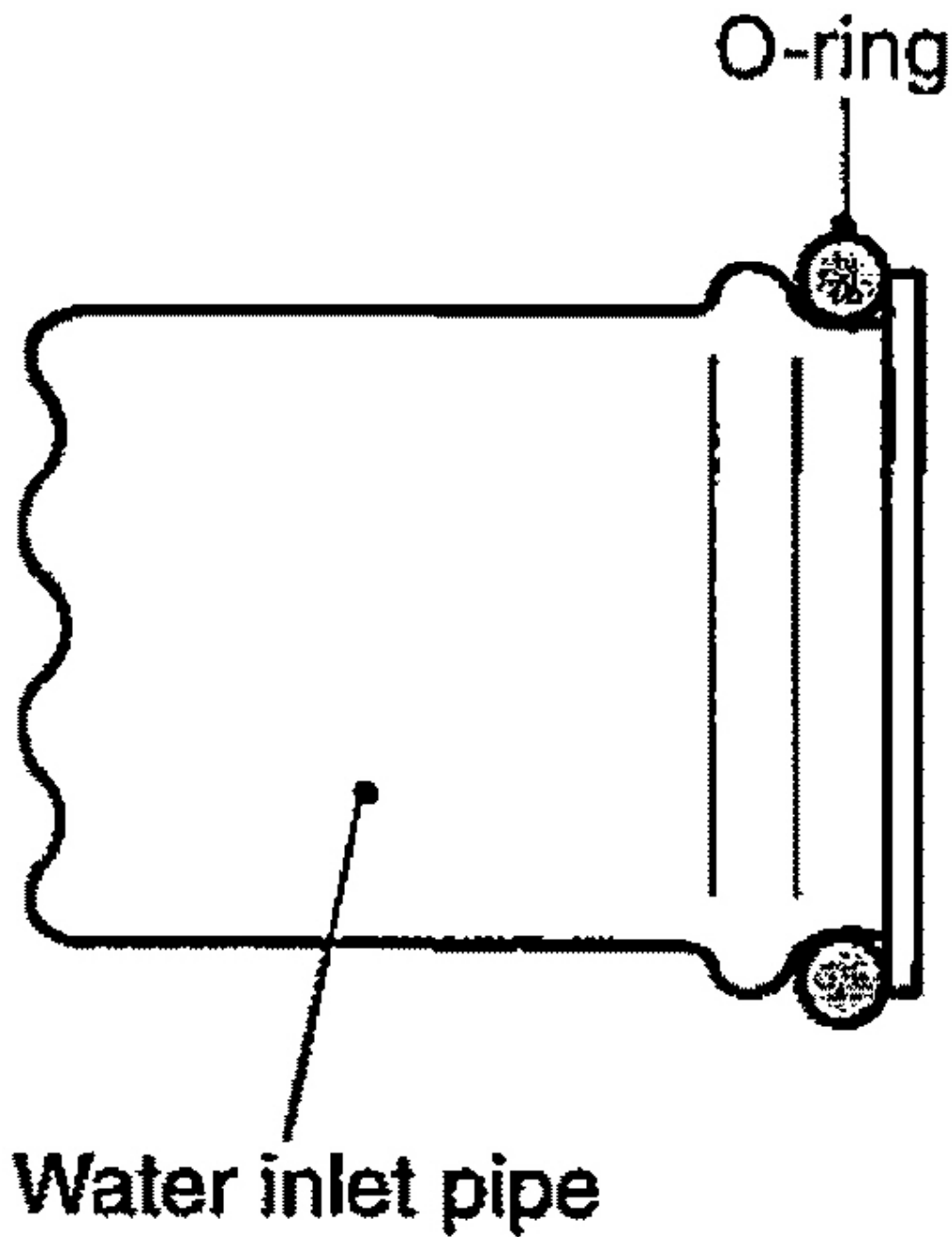

G00320607

Fig. 153: Positioning Water Pipe O-Ring

Courtesy of KIA MOTORS AMERICA, INC.

WATER TEMPERATURE GAUGE UNIT AND SENSOR

1. Apply the sealant on thread and then tighten it to the specified torque.

Description	Recommended sealant	Tightening torque (N · m(kg · cm, lb · ft))
Water temperature sensor	Loctite 962T or equivalent	20-40 (200-400, 14.5-28.9)

G00320608

Fig. 154: Sealant & Tightening Chart

Courtesy of KIA MOTORS AMERICA, INC.

2. Connect the harness to water temperature gauge unit and cable.
3. Connect the battery ground cable.
4. Refill the coolant.

AIR CLEANER

COMPONENTS

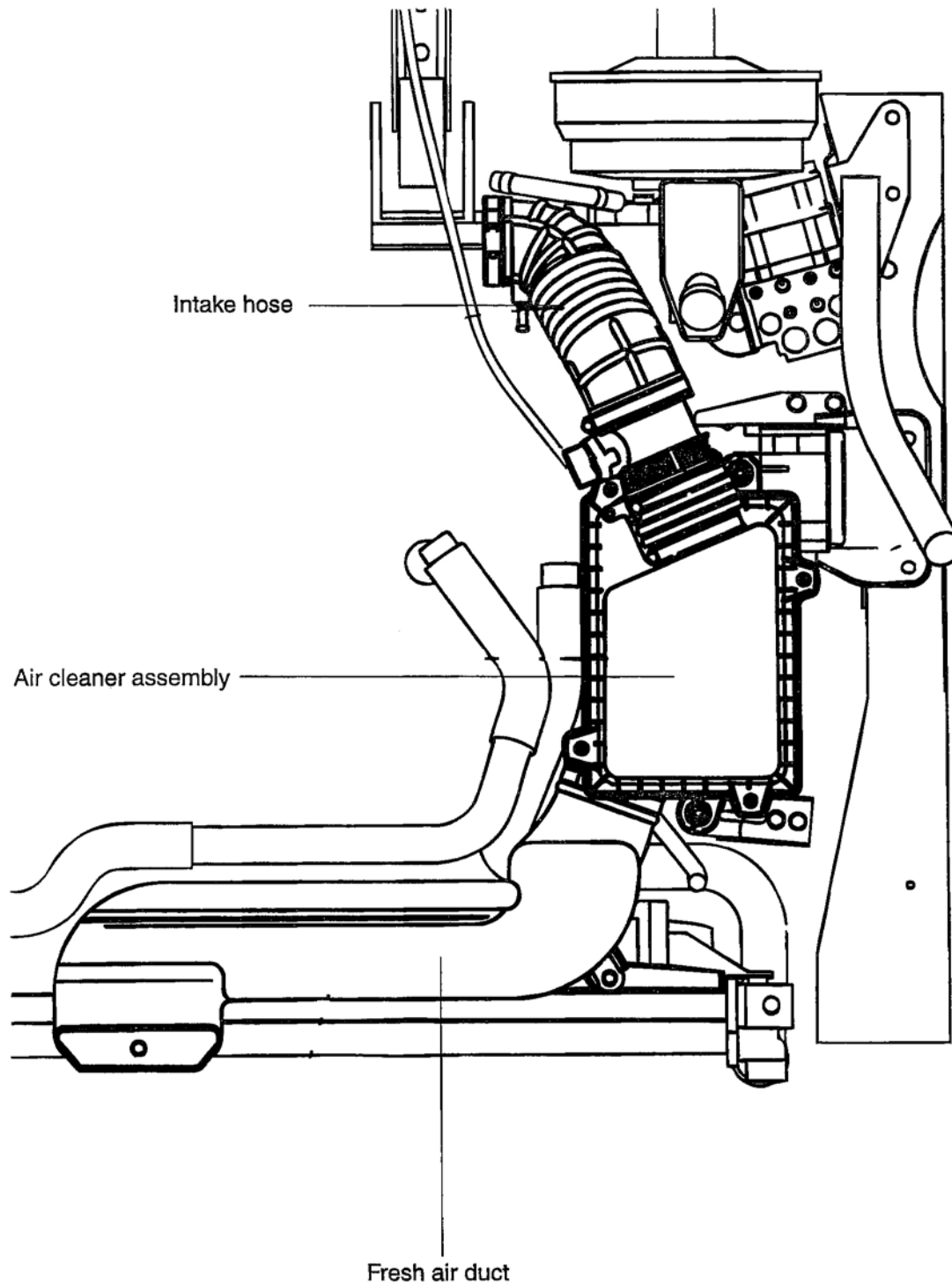

G00320658

Fig. 155: Identifying Air Cleaner Components
Courtesy of KIA MOTORS AMERICA, INC.

REMOVAL

1. Disconnect the AFS connector.

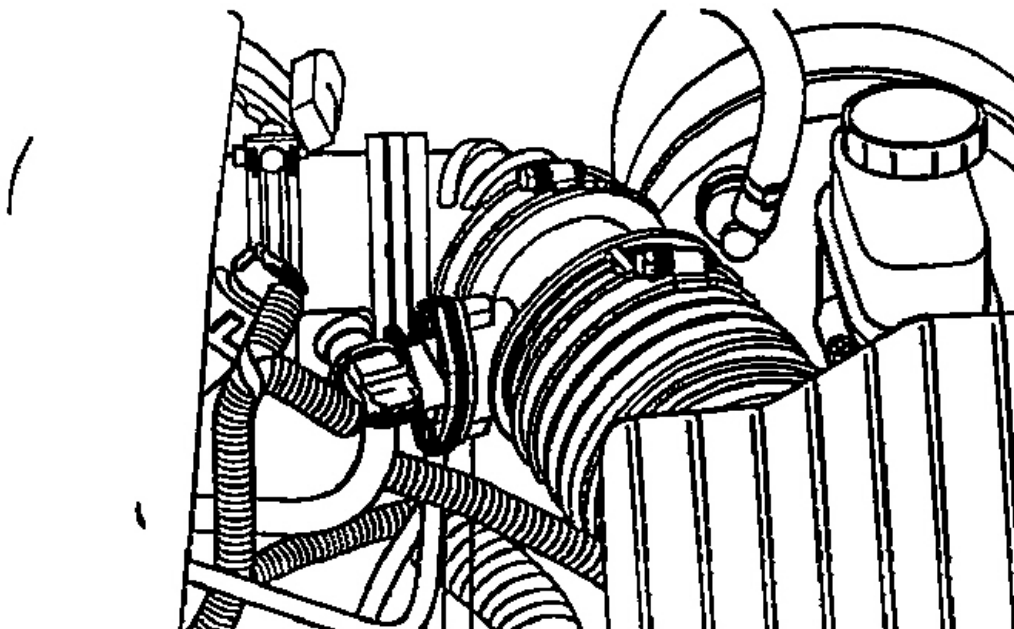

G00320659

Fig. 156: Locating AFS Connector
Courtesy of KIA MOTORS AMERICA, INC.

2. Pull out air duct which is connected to the air inlet hose and air cleaner.
3. Detach the air cleaner.

INSPECTION

1. Inspect the body, cover and packing of air cleaner for distortion, corrosion and damage.
2. Inspect the air duct for damage.
3. Inspect the air cleaner element for dirt, contamination and damage. If element is choked a little, blow air from inside of element to get rid of the dust or other foreign object. If it is contaminated too much, replace it. While replacing it, be cautious not to let foreign object get in.

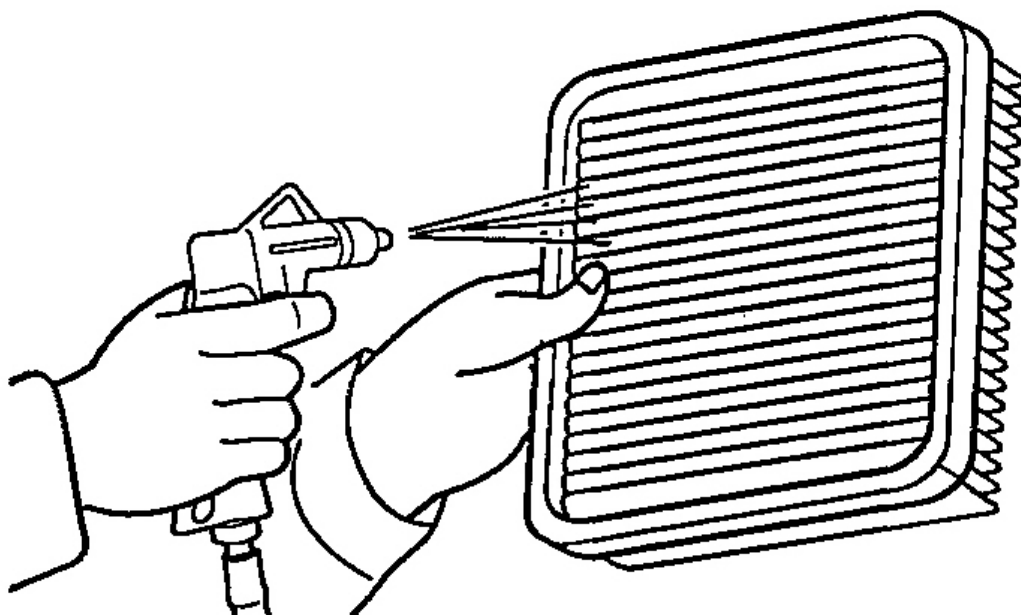

G00320660

Fig. 157: Cleaning Air Cleaner
Courtesy of KIA MOTORS AMERICA, INC.

4. Inspect the air cleaner housing for dirt, contamination and damage.
5. If the inside of air cleaner housing is contaminated, eliminates the contaminated material.

SURGE TANK & INTAKE MANIFOLD

COMPONENTS

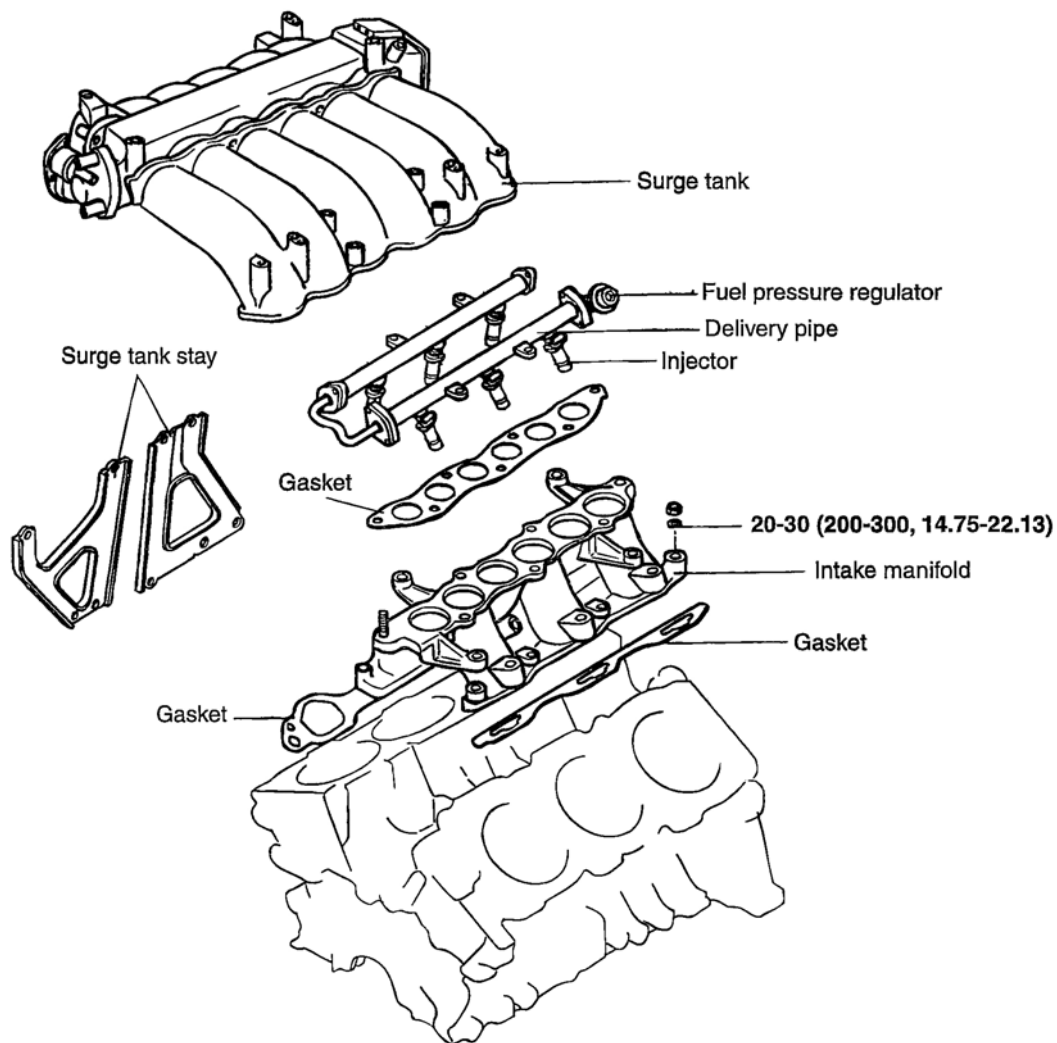

TORQUE : N·m (kg·cm, lb·ft)

G00320645

Fig. 158: Exploded View Of Surge Tank & Intake Manifold
Courtesy of KIA MOTORS AMERICA, INC.

REMOVAL

1. Detach the P.C.V. hose and brake booster vacuum hose.
2. Disconnect the connecting part of vacuum hose.

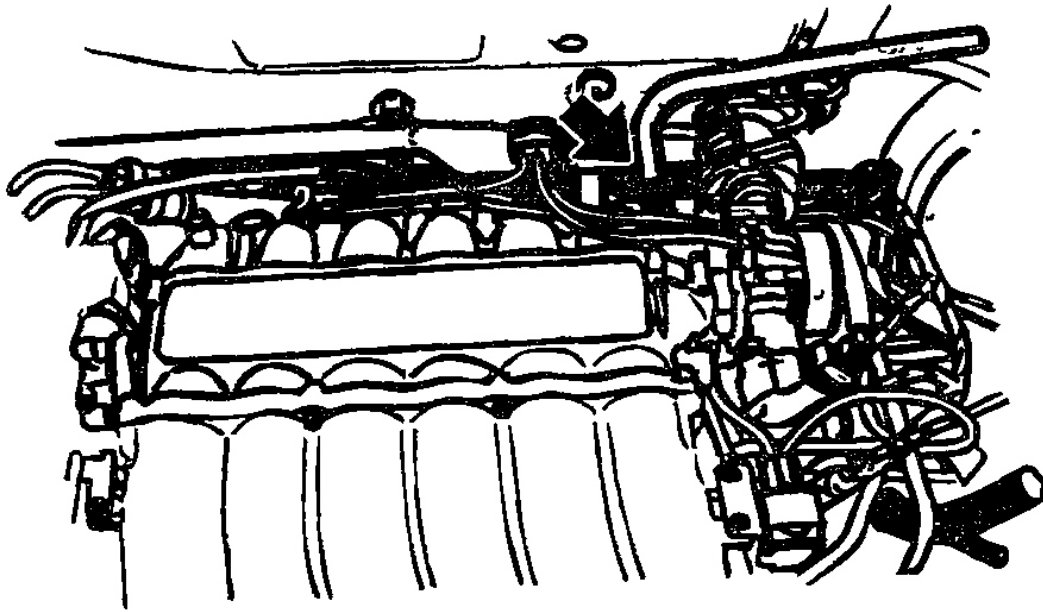

G00320646

Fig. 159: Disconnecting PCV Hose
Courtesy of KIA MOTORS AMERICA, INC.

3. Remove the surge tank stay.

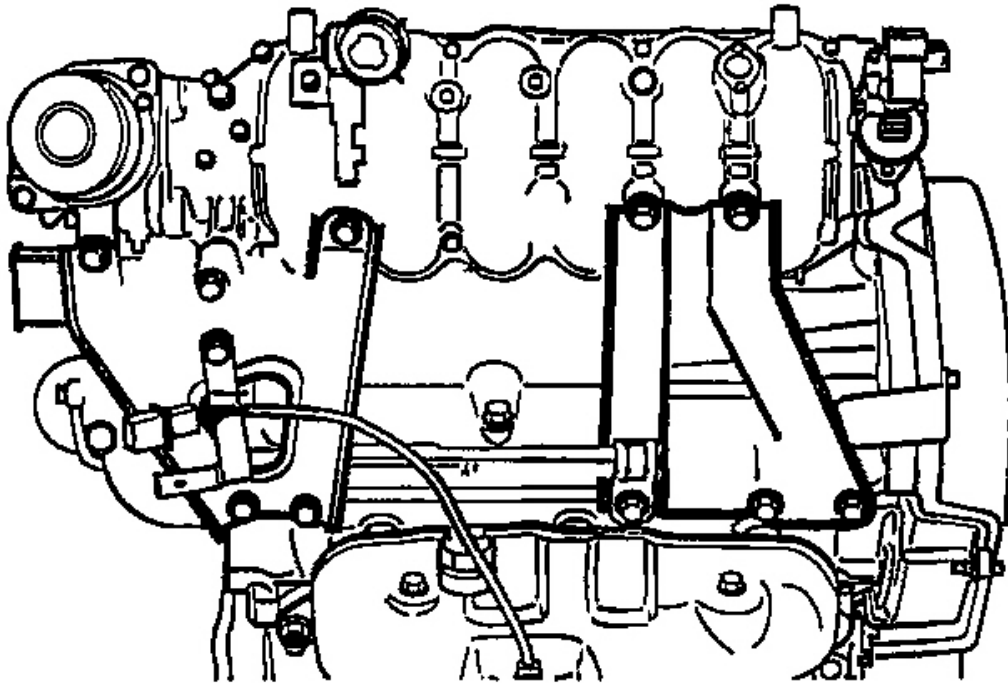

G00320647

Fig. 160: Removing The Surge Tank Stay
Courtesy of KIA MOTORS AMERICA, INC.

4. After reducing the pressure of fuel pipe line to prevent fuel overflow, disconnect the connecting part of the high pressure hose.

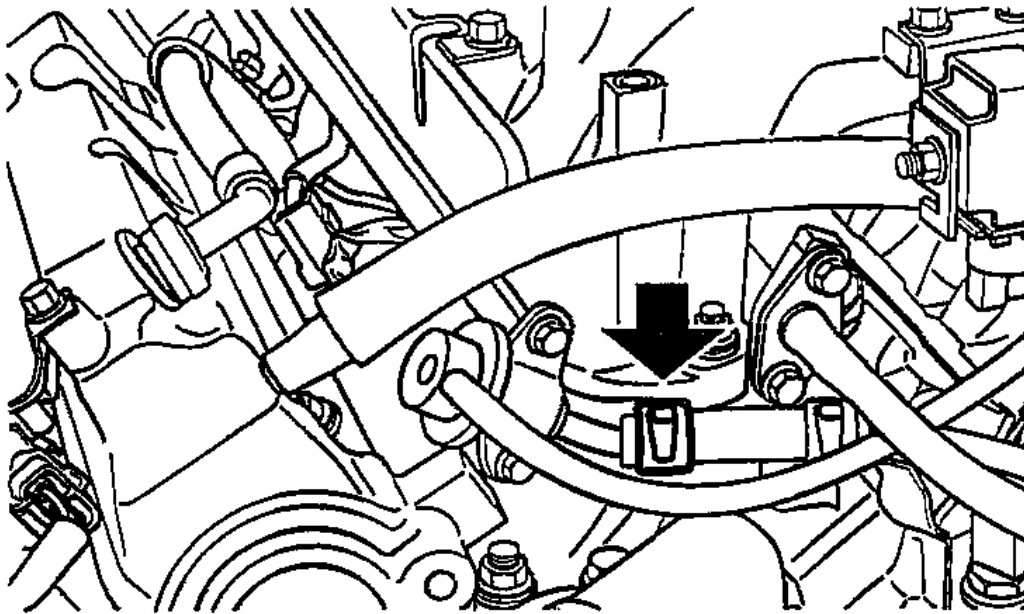

G00320648

Fig. 161: Disconnecting High Pressure Fuel Hose
Courtesy of KIA MOTORS AMERICA, INC.

5. Remove the surge tank.

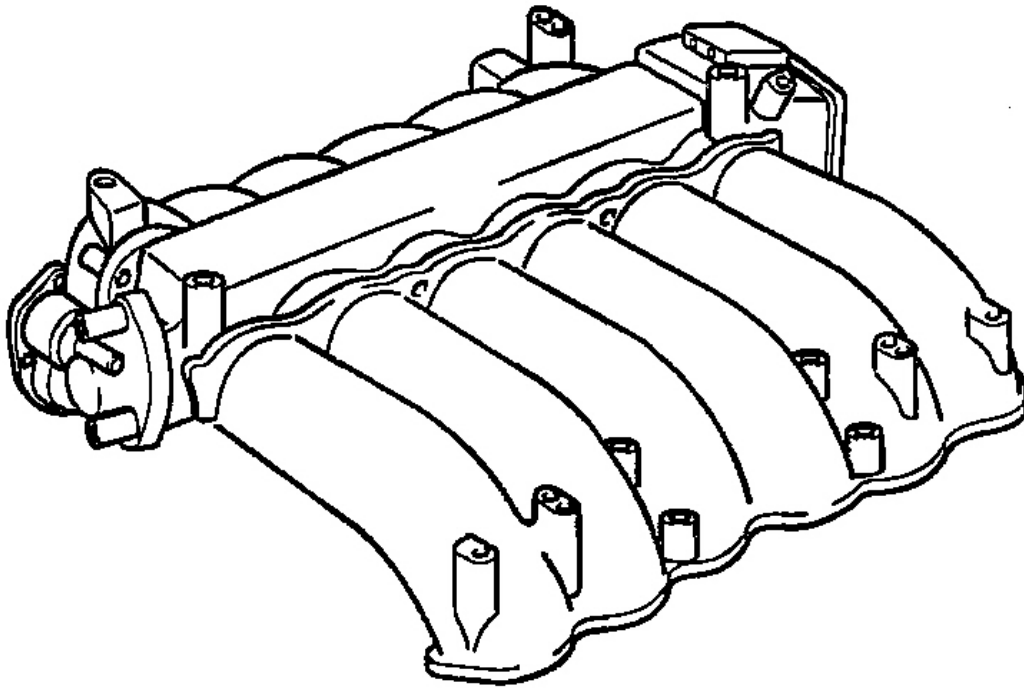

G00320649

Fig. 162: Removing The Surge Tank
Courtesy of KIA MOTORS AMERICA, INC.

6. After removing the surge tank, remove the gasket.

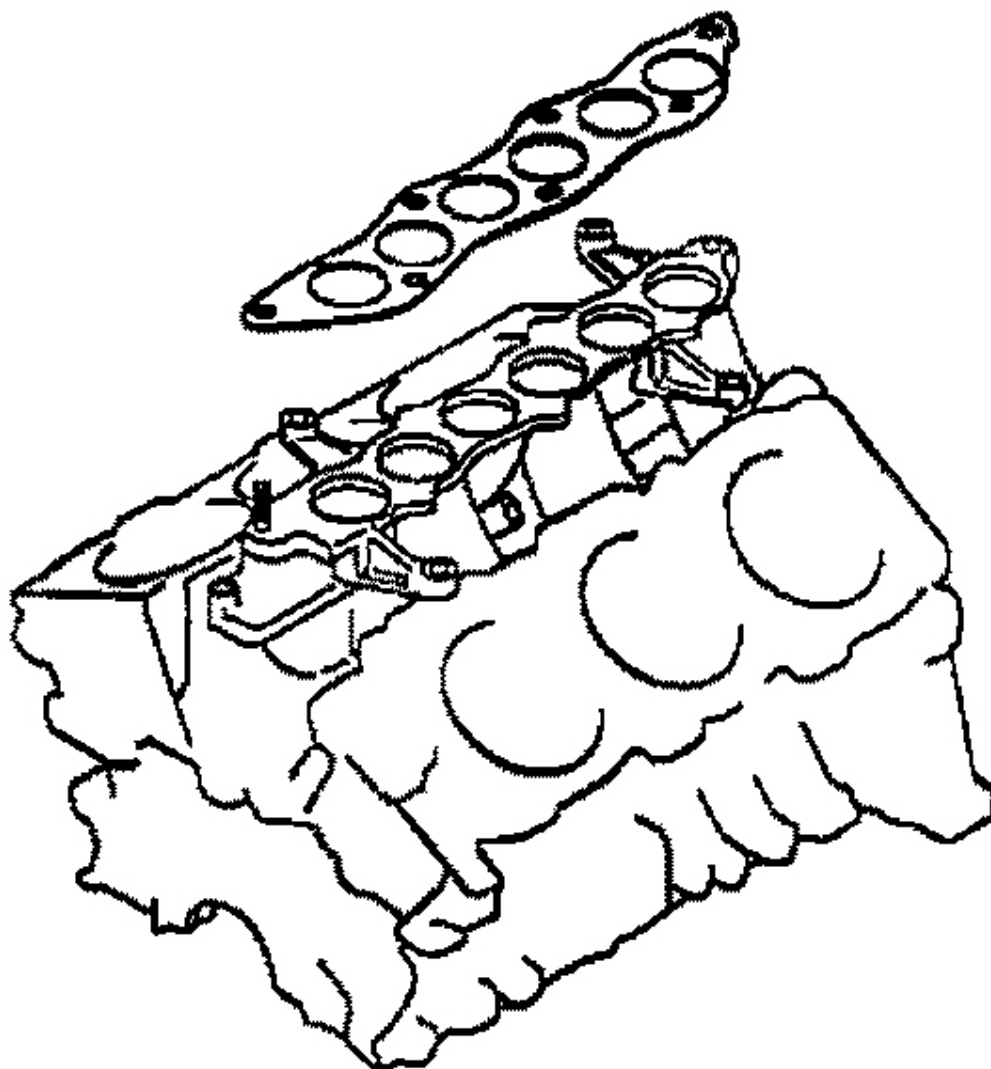

G00320650

Fig. 163: Removing Surge Tank Gasket
Courtesy of KIA MOTORS AMERICA, INC.

7. Disconnect the fuel injector harness connector.

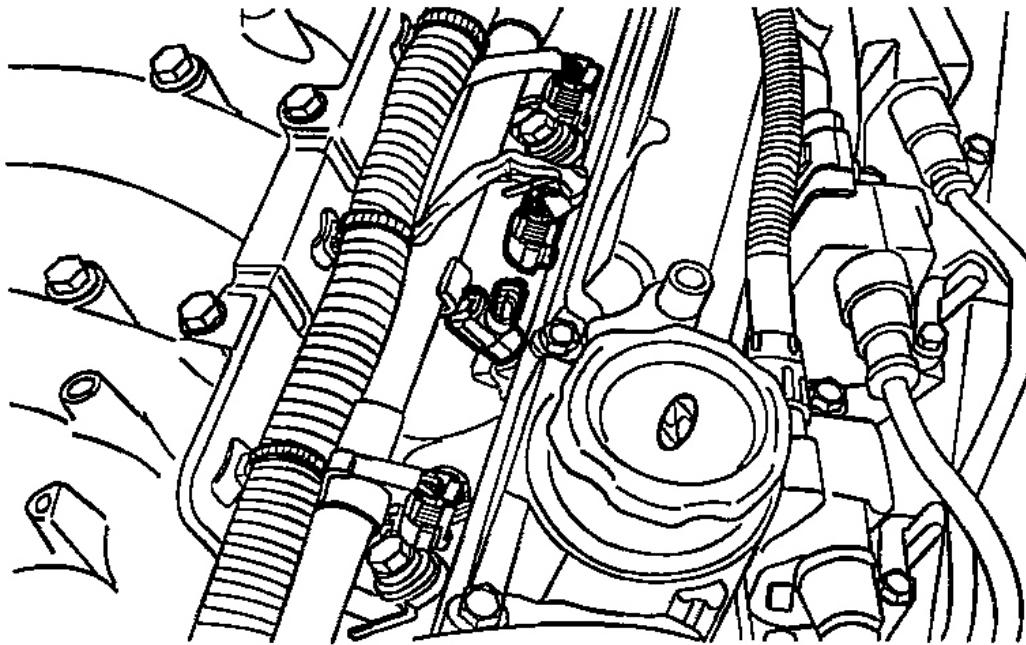

G00320651

Fig. 164: Disconnecting Fuel Injector Harness Connector
Courtesy of KIA MOTORS AMERICA, INC.

8. Remove the delivery pipe with fuel injector and pressure regulator attached.

CAUTION: When removing the delivery pipe, be cautions not to drop the injectors.

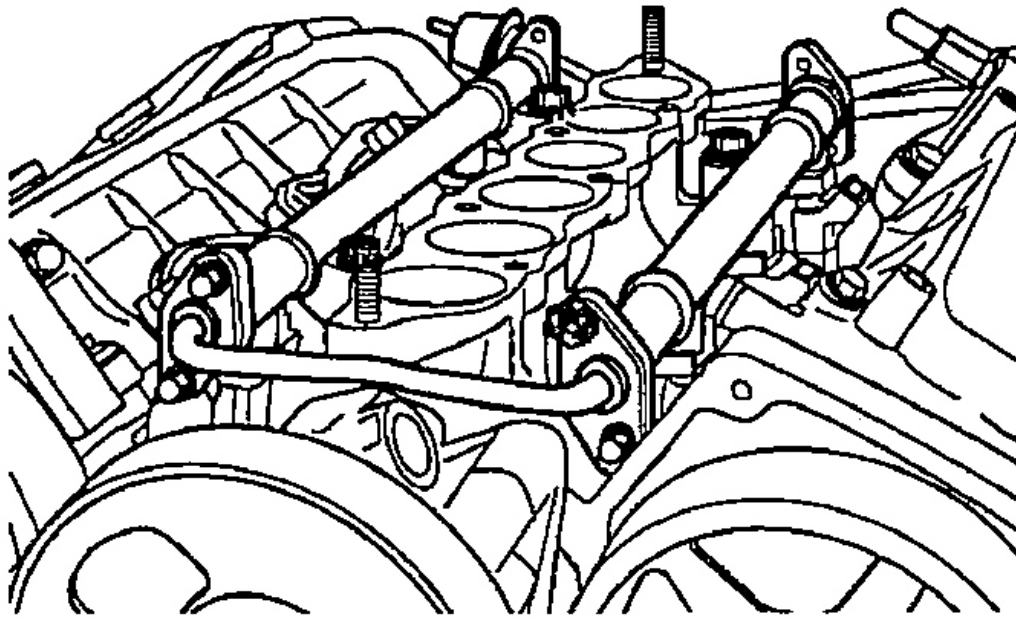

G00320652

Fig. 165: Removing Fuel Delivery Pipe
Courtesy of KIA MOTORS AMERICA, INC.

9. Disconnect the wiring harness connector which is connected to the water temperature gauge unit and water temperature sensor assembly.

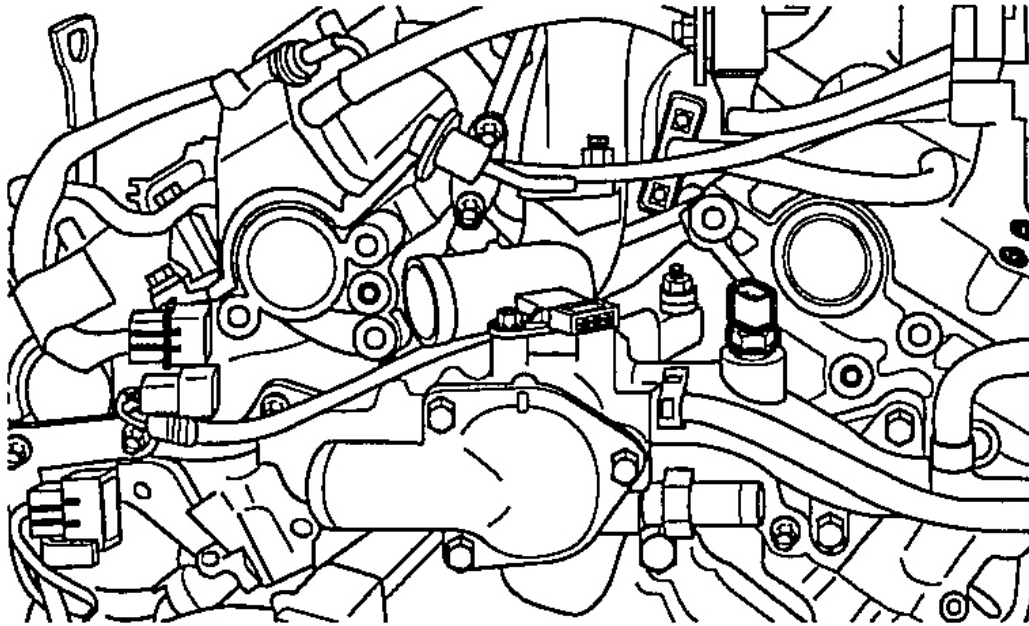

G00320653

Fig. 166: Disconnecting Wiring Harness
Courtesy of KIA MOTORS AMERICA, INC.

10. Remove the water outlet fitting and gasket.
11. Remove the thermostat.

INSPECTION

1. Surge tank
 - a. Inspect the surge tank for damage and crack, if necessary, replace it.
 - b. Check if coolant passage is blocked.
 - c. Inspect the mating surface for warpage using a straight edge or filler gauge.

Standard value: 0.15 mm (0.006 in)

Service limit: 0.2 mm (0.008 in)

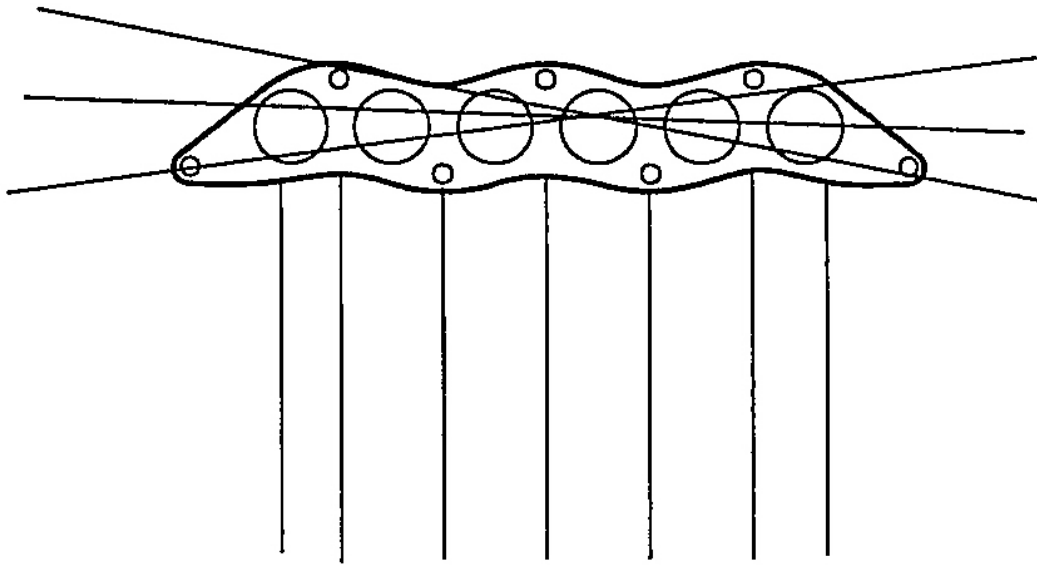

G00320654

Fig. 167: Measuring Surge Tank Flatness
Courtesy of KIA MOTORS AMERICA, INC.

INSTALLATION

1. After replacing the intake manifold gasket, install the surge tank and tighten to the specified torque.

Tightening torque: 19.6-22.6 N.m (200-230 kg.cm, 14.5-16.6 lb.ft.)

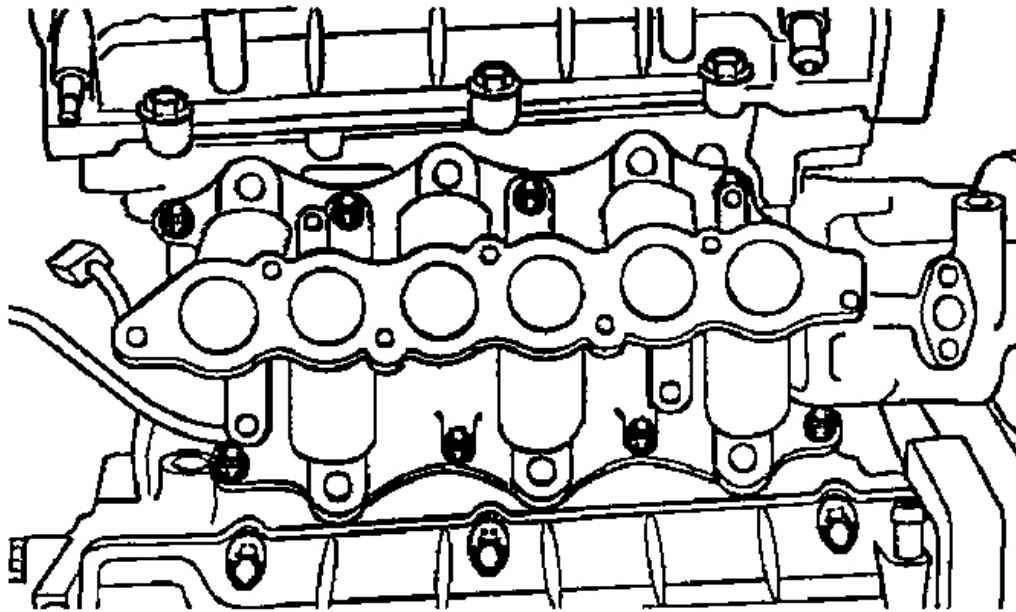

G00320655

Fig. 168: Illustrating Intake Manifold
Courtesy of KIA MOTORS AMERICA, INC.

2. Install the delivery pipe and injector assembly to the intake manifold.

CAUTION: Check the interference between the injector and injector hole in intake manifold.

3. Install the surge tank stay.

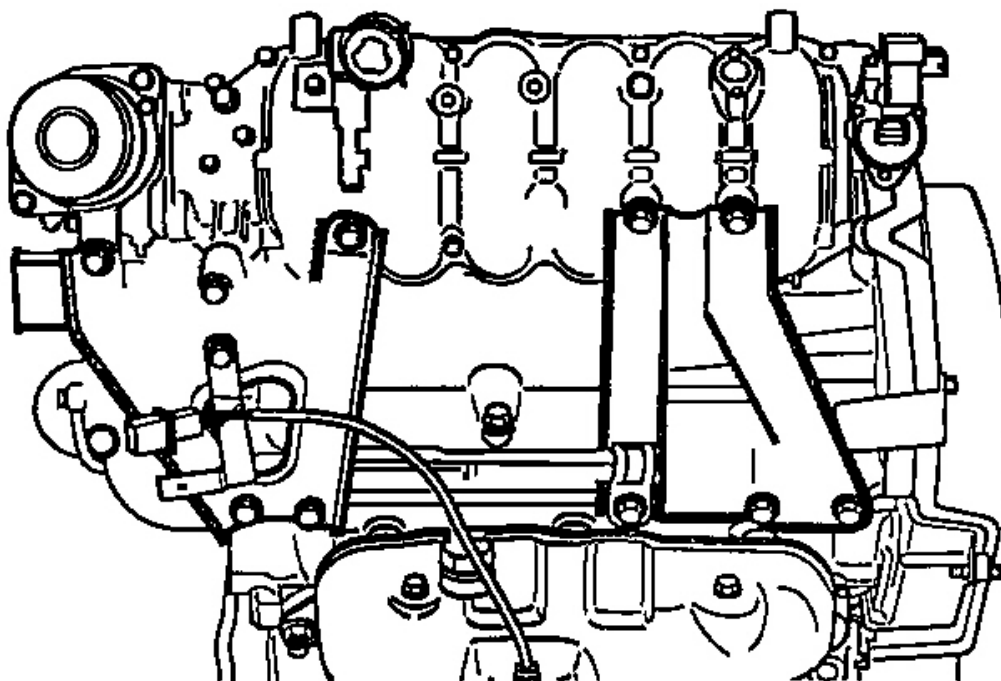

G00320656

Fig. 169: Installing Surge Tank Stay
Courtesy of KIA MOTORS AMERICA, INC.

4. Install the fuel injector connector and wiring harness.
5. Connect the high pressure fuel hose.
6. Connect the various vacuum hose.
7. Connect the PCV valve hose and brake booster hose.
8. Install the idle speed actuator.
9. Installation of thermostat
 - a. Install the water outlet fitting gasket which is attached to thermostat housing.

Align the arrangement mark on thermostat housing with jiggle valve.

- b. Apply the sealant on coolant temperature sensor and cooling water temperature gauge unit.
10. Install the air hose.
11. Install the accelerator cable.

EXHAUST SYSTEM

EXHAUST MANIFOLD

COMPONENTS

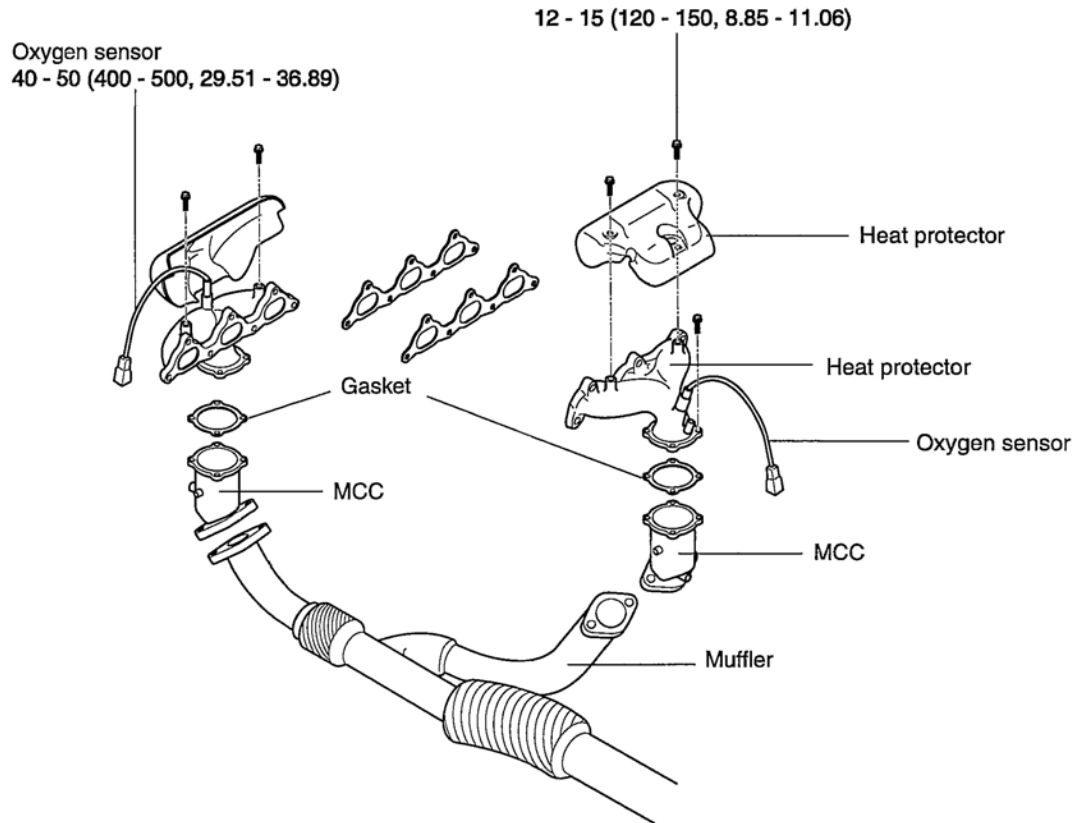

TORQUE : N·m(kg·cm, lb·ft)

G00320638

Fig. 170: Exploded View Of Exhaust Manifold
Courtesy of KIA MOTORS AMERICA, INC.

REMOVAL

1. Remove the heat protector.

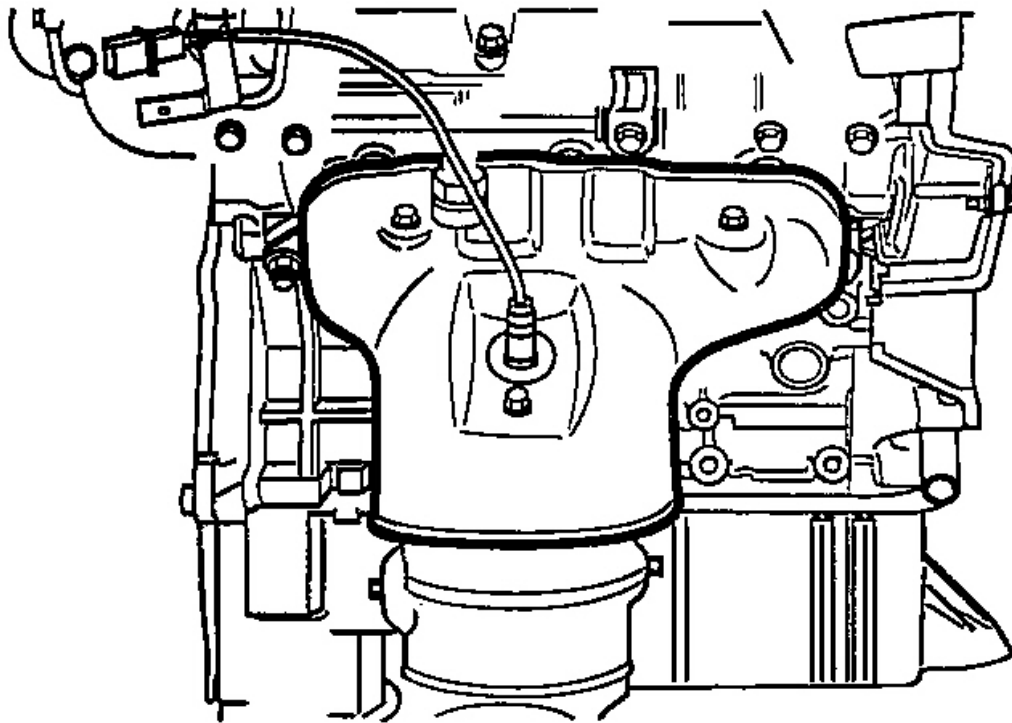

G00320639

Fig. 171: Removing Heat Protector
Courtesy of KIA MOTORS AMERICA, INC.

2. Remove the exhaust manifold.

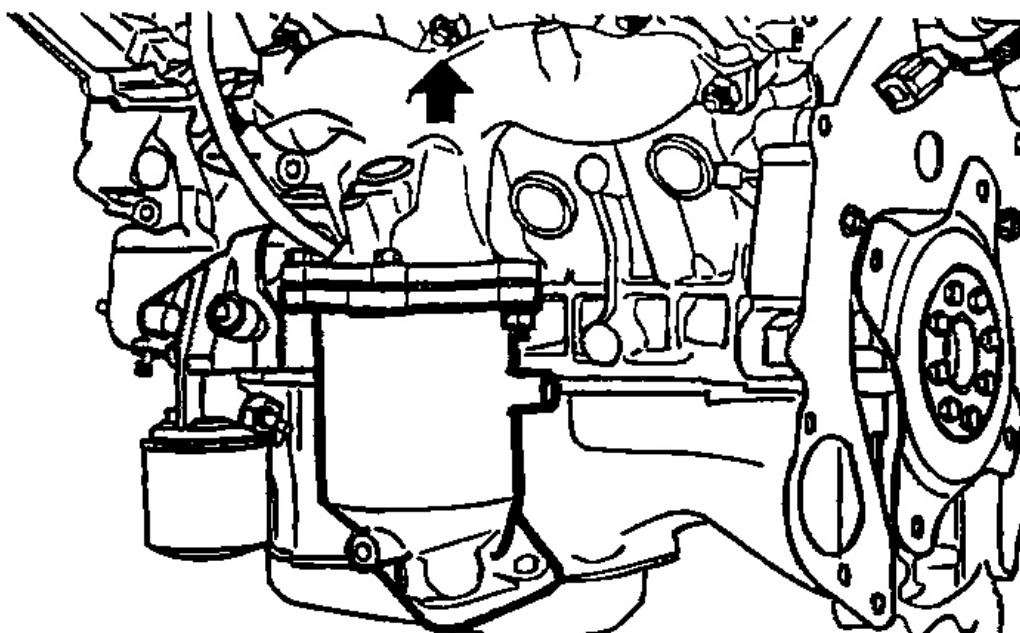

G00320640

Fig. 172: Removing Exhaust Manifold
 Courtesy of KIA MOTORS AMERICA, INC.

INSPECTION

1. Exhaust manifold
 - a. Check for cracks, replace if necessary.
 - b. Check the distortion in mating surface with a straight edge and filler gauge

Description	Torsion (mm)
Standard value	0.15 (0.006 in)
Limit	0.3 (0.012 in)

G00320641

Fig. 173: Exhaust Manifold Flatness Specifications
Courtesy of KIA MOTORS AMERICA, INC.

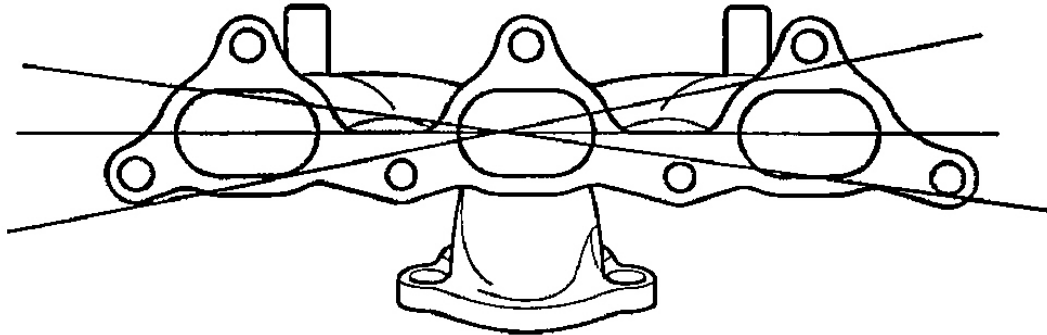

G00320642

Fig. 174: Measuring Exhaust Manifold Flatness
Courtesy of KIA MOTORS AMERICA, INC.

2. Heat protector, gasket

Check for damages and cracks in all parts, replace if necessary.

INSTALLATION

1. After installing the gasket, install the exhaust manifold.

Tightening torque: 40-50 N.m (400-500 kg.cm, 28.9-36.2 lb.ft.)

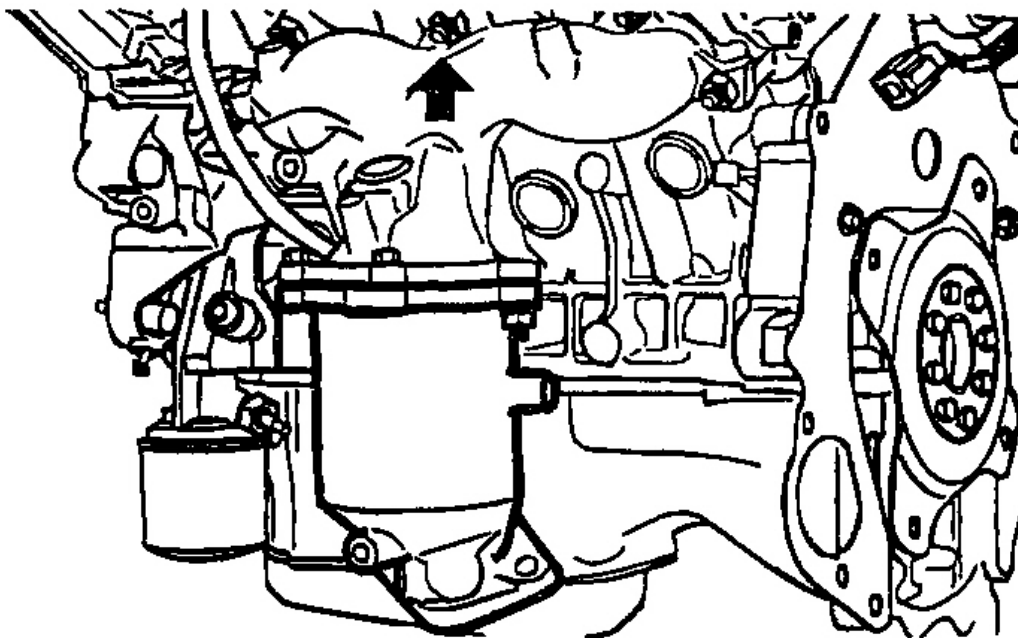

G00320643

Fig. 175: Installing Exhaust Manifold
Courtesy of KIA MOTORS AMERICA, INC.

CAUTION: Use only new exhaust manifold gaskets and nuts.

2. Install the heat protector.

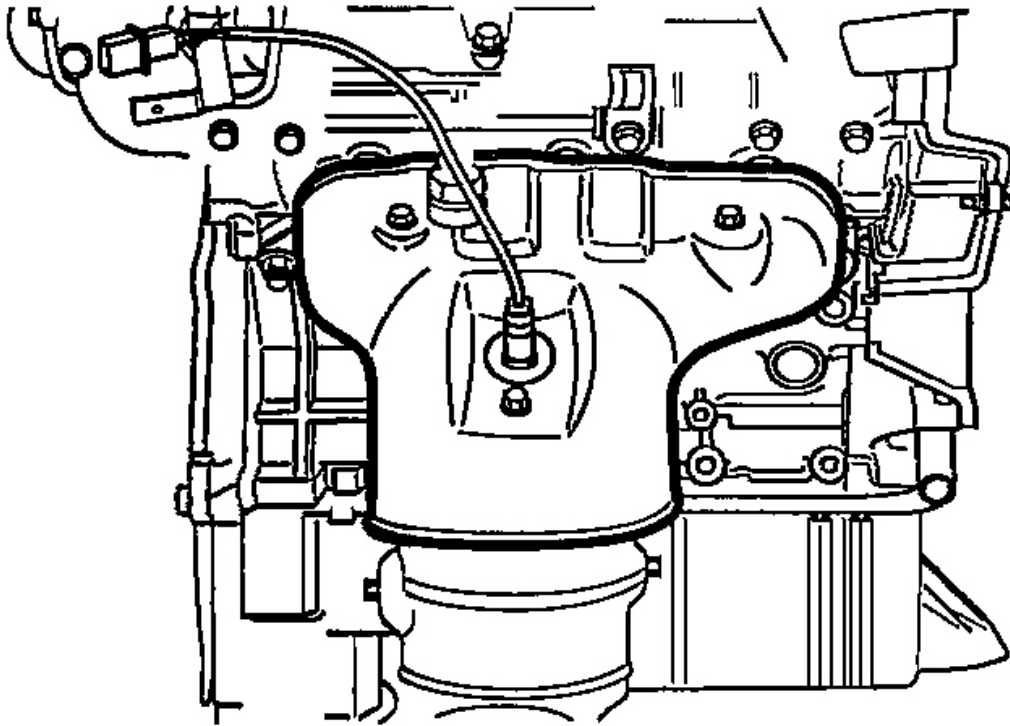

G00320644

Fig. 176: Installing Heat Protector
Courtesy of KIA MOTORS AMERICA, INC.

MUFFLER

COMPONENTS

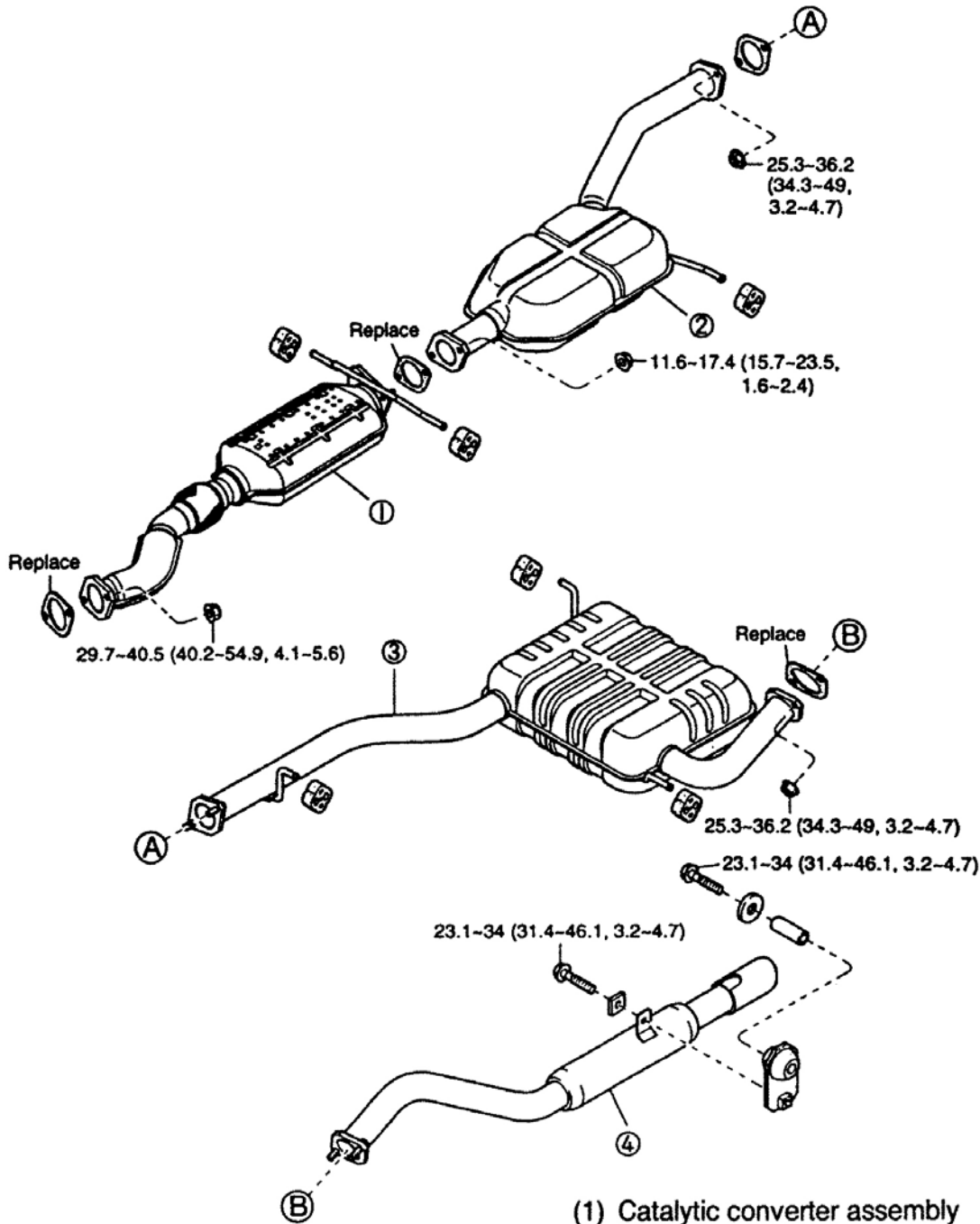

TORQUE : lb·ft (N·m, kg·m)

- (1) Catalytic converter assembly
- (2) Pre-silencer assembly
- (3) Main-silencer assembly
- (4) Tail pipe assembly

G00368070

Fig. 177: Identifying Muffler Components
 Courtesy of KIA MOTORS AMERICA, INC.