

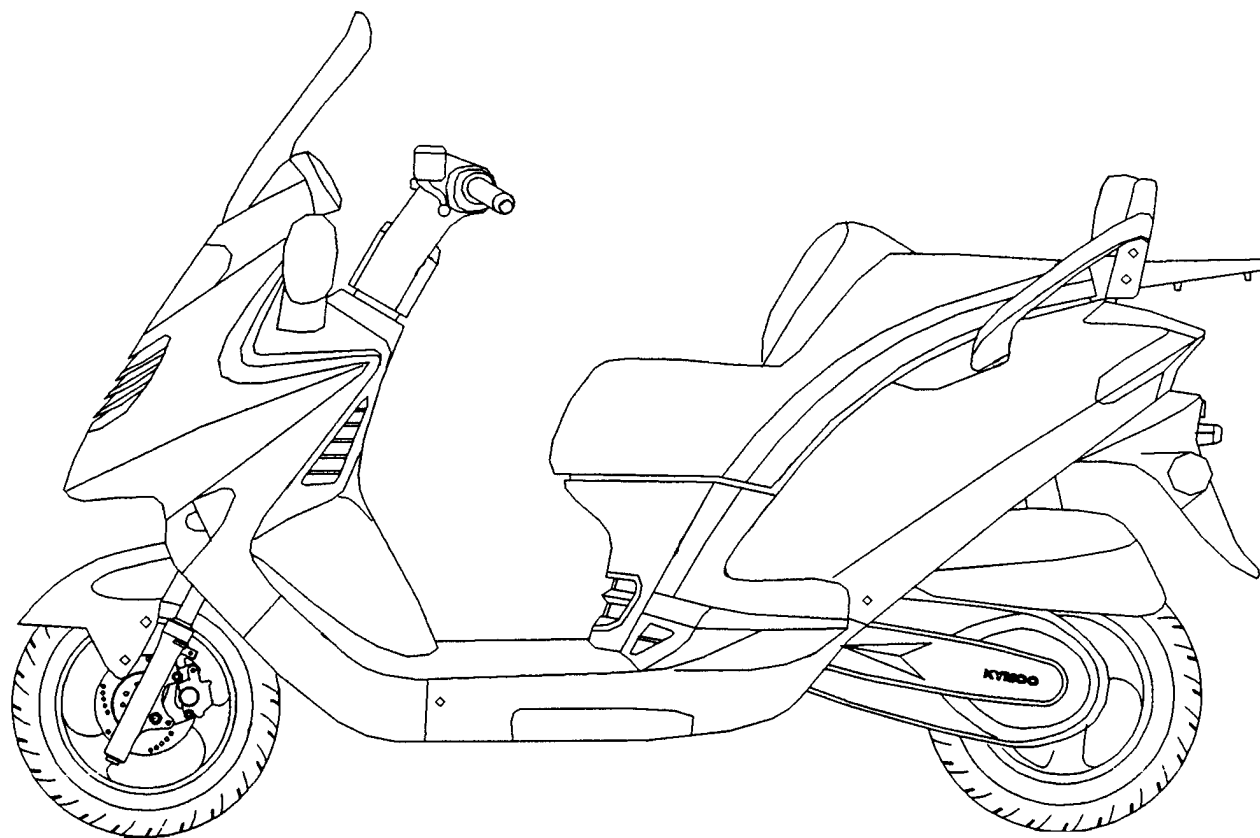

GRAND DINK

零件型錄
PARTS CATALOGUE

SH50DB(AT) FEB/14 /2004 制訂



光陽機車

KYMCO

光陽機車

KYMCO

光陽機車

KYMCO

前 言

- 本零件目錄適用於 SH50DB(AT) 機種，訂購零件時，請參照本冊。
- 本冊之配色表僅供參考，若與實車不符之處，以實車為準。
- 販賣記號(Sales mark)：
 - 1、註明 ★★ 記號，表示訂購該零件時，請參照機車相片及配色表，並請在基本零件號碼最後加上色碼。
 - 2、註明 ★ 記號，表示該零件為補修零件。
- 本冊付梓印刷倉促，倘有錯誤或遺漏之處，敬請不吝賜教指正。

ABOUT THIS PARTS LIST

- This parts list is compiled all service parts for model SH50DB(AT)。
- Any difference between color chart and motorcycle will be revised according to motorcycle。
- The sales mark：
 - 1、marking "★★" must add color code in the end before ordering parts。
 - 2、marking "★" is a saleable item。
- When modification or additions to this parts list are made a revised edition at an appropriate time。

目 次

●前 言	1
●SH50DB(AT)配色表	5
●引擎分組圖	7
●車架分組圖	9
●引擎零件號碼表	13
●車架零件號碼表	49
●零件號碼索引	129

CONTENTS

●ABOUT THIS PARTS LIST	1
●COLOR CHART OF SH50DB(AT)	5
●CONTENTS-ENGINE GROUP	7
●CONTENTS-FRAME GROUP	9
●ENGINE PARTS LIST	13
●FRAME PARTS LIST	49
●PART NO. INDEX	129

機種名稱 (MODEL)				SH50DB(AT) COLOR CHART				
項	相片號碼 (PHOTO NO)			NO.1	NO.2	NO.3	NO.4	NO.5
次	主體色 (BASIC COLOR)			亮銀	深鐵灰	深藍	豔紅	黃綠
NO	色碼 (CODE)			Bright Silver	Dark Gray Metallic	Deep Blue Metallic	Ruby Red	Yellow Green
	色別零件名稱(PARTS NAME)	基本零件號碼(PARTS NO)	版數(VERSION)	NH045MA	NH124MA	PB183MA	RR004CA	YG025MA
1	COVER SCREEN	64301-KKC4-900	0	N8P	NFP	BHP	R1P	W3P
2	COVER SET R SIDE	83500-KKC4-900	0					
3	COVER SET L SIDE	83600-KKC4-900	1					
4	MIRROR ASSY R BACK	88110-KKC4-900	7					
5	MIRROR ASSY L BACK	88120-KKC4-900	7					
6	SKIRT R SIDE	64305-KKC4-900	1					
7	SKIRT L SIDE	64306-KKC4-900	2					
8	MOLDING FR	64302-KKC4-900	0					
9	FENDER FRONT	61110-KHD8-900	2					
10	COWL UNDER	64400-KKC4-900	0					
11	COVER RR CENTER	83750-KKC4-900	1	N8P				
12	METER COVER FR	37203-KKC4-900	0					
13	METER COVER RR	37204-KKC4-900	0					
14	COVER R HANDLE LOW	53206-KKC4-900	0					
15	COVER L HANDLE LOW	53207-KKC4-900	0					
16	LEG SHIELD	81131-KKC4-900	0					
17	LID LEG SHIELD	81132-KEB7-900	0					
18	FLOOR PANEL	64310-KKC4-900	0					
19	COVER R PILLION STEP	64311-KKC4-900	3					
20	COVER L PILLION STEP	64321-KKC4-900	2					
21	MAT FLOOR	64320-KKC4-900	0	N1R				
22	LID RESERVE TANK	81136-KKC4-900	0					
23	GRID R LEG SHIELD	53214-KKC4-900	0					
24	GRID L LEG SHIELD	53224-KKC4-900	0					
25	GRIP R PILLION STEP	64312-KKC4-900	3					
26	GRIP L PILLION STEP	64322-KKC4-900	1					
27	COVER METER	53204-KKC4-900	2					
28	COVER CENTER	80151-KKC4-900	0					
29	GRID R LEG SHIELD	81137-KKC4-900	0					
30	GRID L LEG SHIELD	81147-KKC4-900	0					
31	LEVER R STRG HNDL	53175-KFA5-E10	0	M3A				
32	LEVER L STRG HNDL	53178-KFC8-E10	0					
33	COVER HANDLE UP	53205-KKC4-900	0	N8P				
34	GRILL HANDLE UP	53208-KKC4-900	0					
35	COVER L	1134A-KHE7-900	3	N1R				
36	GRIP R HANDLE	53140-KKC4-900	0					
37	GRIP L HANDLE	53166-KGB5-900	0					
38	SIDE R GRIP	81400-KKC4-900	0					
39	SIDE L GRIP	81500-KKC4-900	0					
40	COVER BATTERY	50326-KKC4-900	0	NJA				
41	CALIPER ASSY RR	43100-KKC4-900	0					
42	BODY CALIPER FR	45200-KKC4-900	1					
43	WHEEL FR CAST	44650-KHD8-30A	3					
生產日期 (DATE OF STARTING-SALES)				2004.02.17	2004.02.17		2004.02.17	

CONTENTS-FRAME GROUP

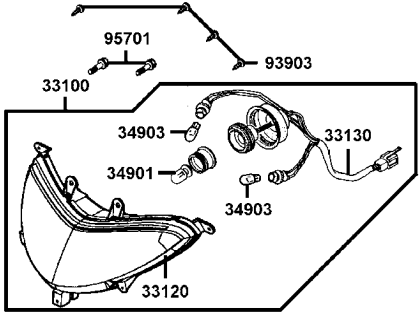
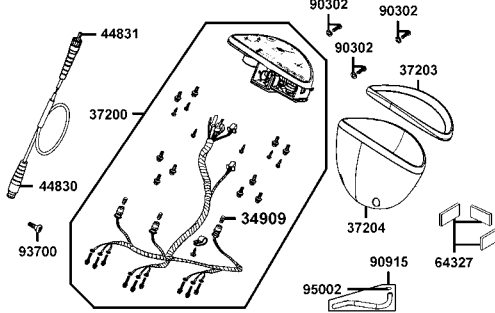
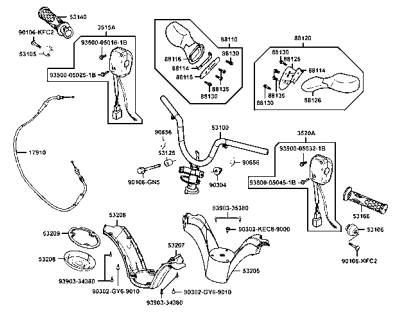
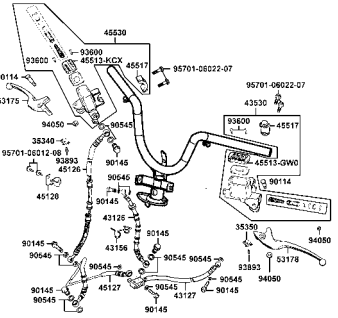
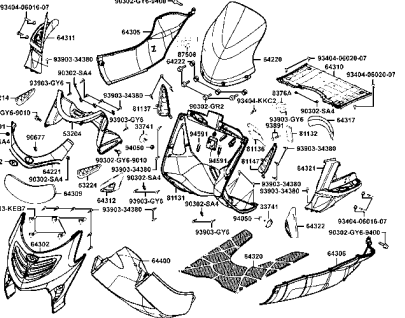
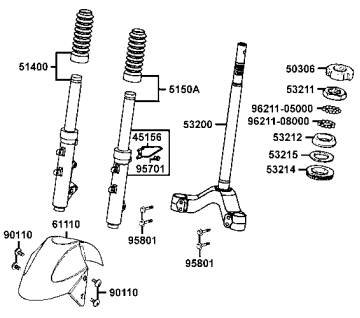
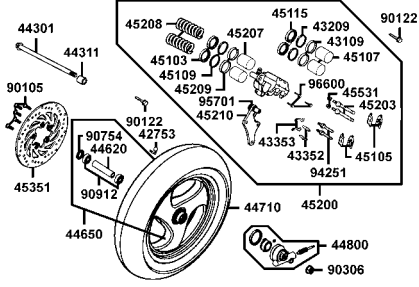
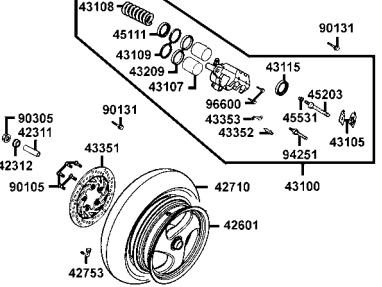
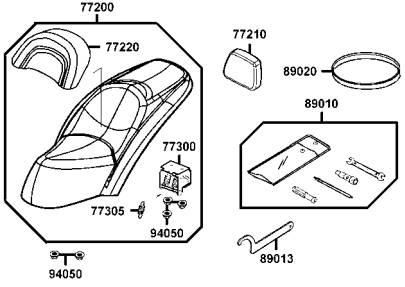
<p>F1 前燈 -51- Head Light</p> 	<p>F2 儀錶 -53- Speedometer</p> 	<p>F3 轉向手柄●手柄蓋 -55- Handle Steering●Handle Cover</p> 
<p>F4 煞車主油缸 -59- Brake Master Cylinder</p> 	<p>F5 前護蓋●腳踏版 -63- Front Cover●Floor Panel</p> 	<p>F6 前避震器 -69- Front Cushion</p> 
<p>F7 前輪 -71- Front Wheel</p> 	<p>F8 後輪 -75- Rear Wheel</p> 	<p>F9 座墊 -79- Seat</p> 

CONTENTS-FRAME GROUP

F10 油箱
Fuel Tank **-81-**

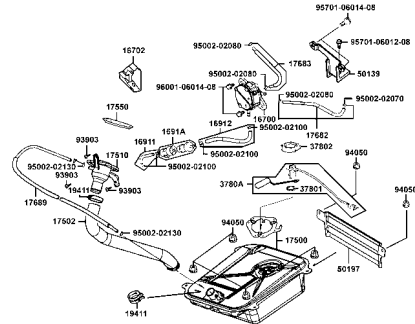

F11 電瓶
Battery **-85-**

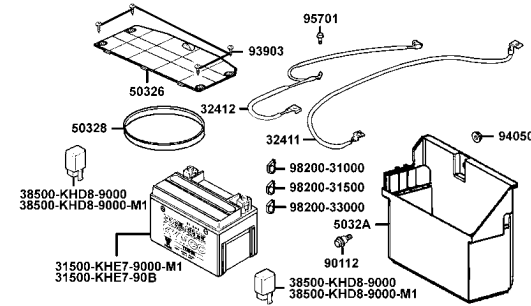

F12 車體蓋●行李箱
Body Cover●Luggage Box **-87-**

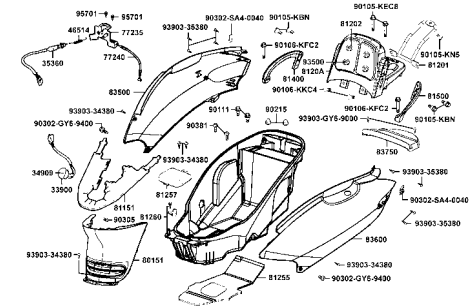

F13 空氣濾清器
Air Cleaner **-91-**

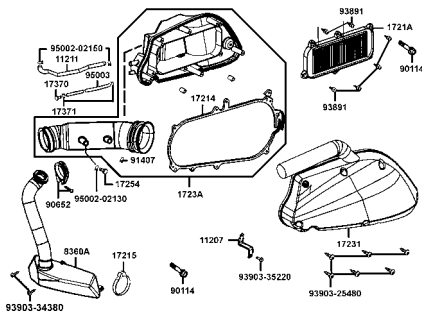

F14 排氣管
Exhaust Muffler **-93-**

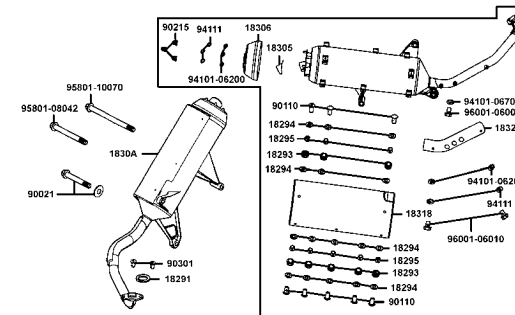

F15 腳架●起動踏桿
Stand●Kick Starter Arm **-95-**

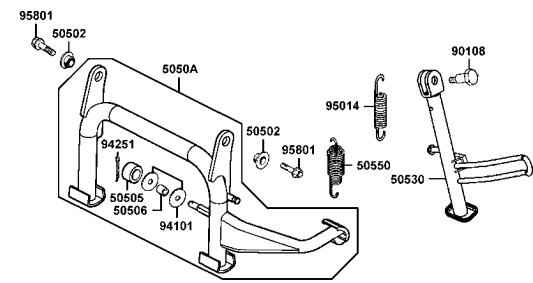

F16 後避震器
Rear Cushion **-97-**

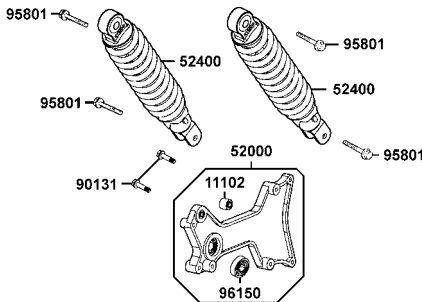

F17 前方向燈
Front Winker **-99-**

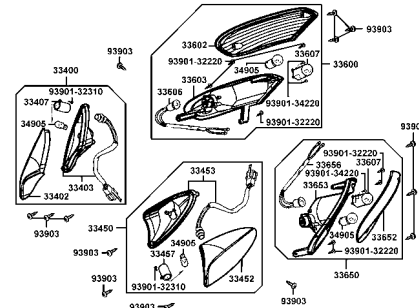

F18 後燈●後土除
Rear Light●Rear Fender **-103-**

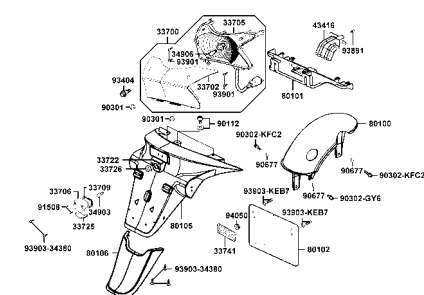

CONTENTS-FRAME GROUP

F19 主電路配線 Wire Harness

-107-

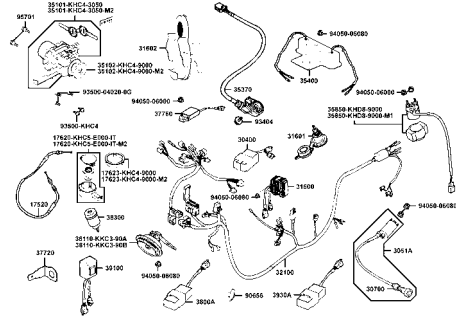

F20 車體 Frame Body

-111-

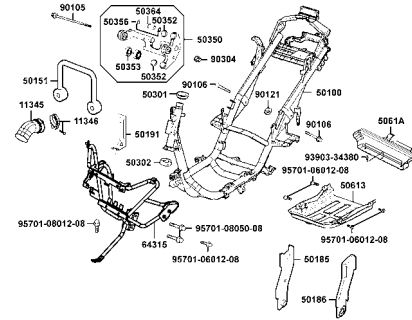

F21 水箱 Radiator

-115-

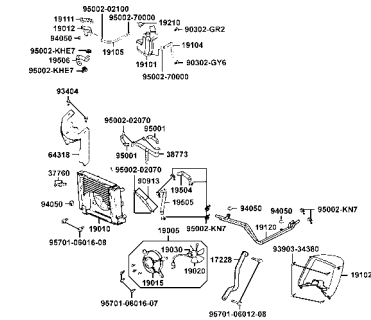

F22 前叉附件 Separated Parts Of Fr Fork

-119-

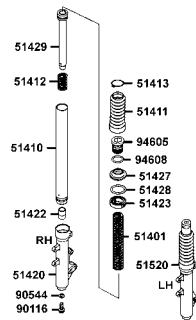

F23 二次空氣濾清器 Air Cleaner Two

-121-

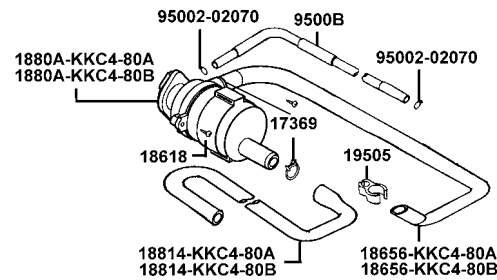

F24 注意標籤 Caution Label

-123-

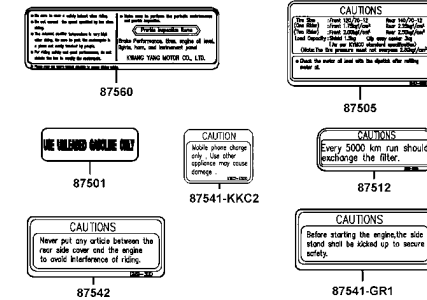

F25 標徽●貼紙 Emblem●Stripe

-125-



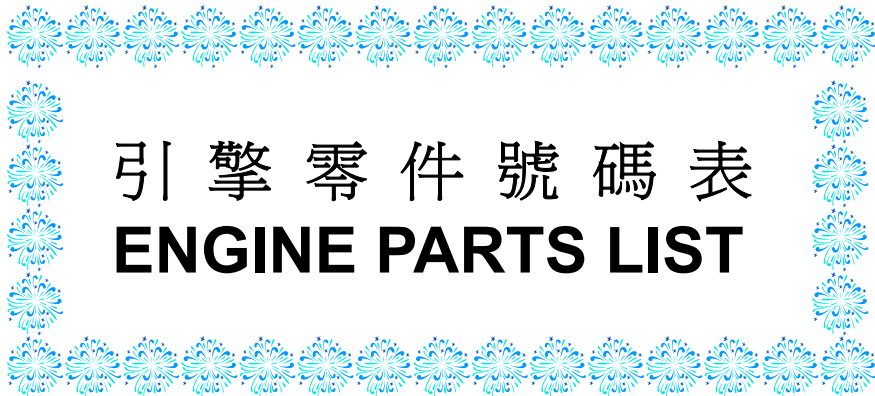

引擎零件號碼表
ENGINE PARTS LIST

E 1 Crank Case

曲
軸
箱

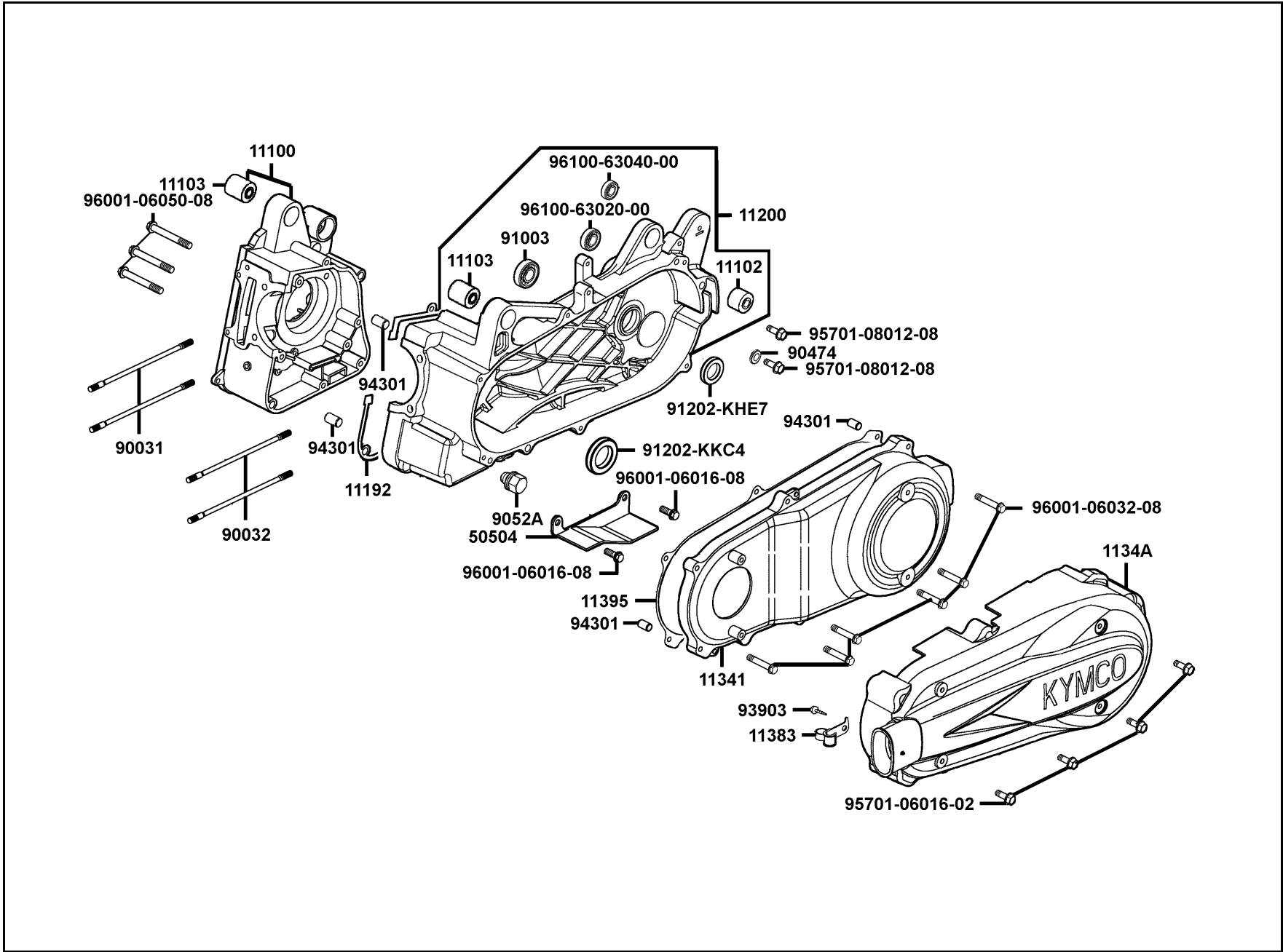

販賣記號 Sales mark	項目 Ref no	零件號碼 Part no	版數 Ver	英文名稱 Description	中文名稱 Chinese	需要用量 Regd no	參考價 Ref Price
		11100-KHE7-305	5	CASE SET R CRANK	右曲軸箱	1	
		11102-187-0030	3	RUB BUSH ENG HANGER	引擎吊架襯套橡皮	1	
		11103-KHE7-9000	0	RUB BUSH ENG HANGER	引擎吊架襯套	2	
		11192-KHE7-9000	0	GASKET CRANK CASE @ A	曲軸箱墊片	1	
		11200-KKC4-3050	1	CRANK CASE SET L	左曲軸箱	1	
		11341-KHE7-9000	0	COVER LEFT	左曲軸箱蓋	1	
**		1134A-KHE7-900	3	COVER COMP L COVER	左曲軸箱蓋外蓋	1	
		11383-KDU-9000	0	CLAMPER BREATHER DRAIN TUBE	通氣管夾	1	
		11395-KHE7-9000	0	GASKET L COVER @ A	左曲軸箱蓋墊片 A	1	
		50504-KKC4-900	2	STAY COMP MAIN STAND STOPPER	主腳架制止板	1	
		90031-KBE-9000	0	BOLT A STUD 8MM	雙頭螺絲 8MM	2	
		90032-KBE-9000	0	BOLT B STUD 8MM	雙頭螺絲 8MM	2	
		90474-333-0010	0	WASHER 8MM	華司 8MM	1	
		9052A-GY6-9500	0	BOLT ASSY DRAIN PLUG	洩油螺絲	1	
		91003-KHE7-900	0	BRG BALL RADIAL	軸承	1	
		91202-KHE7-9000	0	OIL SEAL 22*34*6	油封 22*34*6	1	
		91202-KKC4-900	0	OIL SEAL 27*42*7	油封 27*42*7	1	
		93903-45380	0	SCREW TAPPING 5*16	螺絲 5*16	1	
		94301-10160	0	DOWEL PIN 10*16	定位銷 10*16	4	
		95701-06016-02	0	BOLT FLANGE 6*16	螺絲 6*16	4	

E 1

E 1 Crank Case

曲
軸
箱

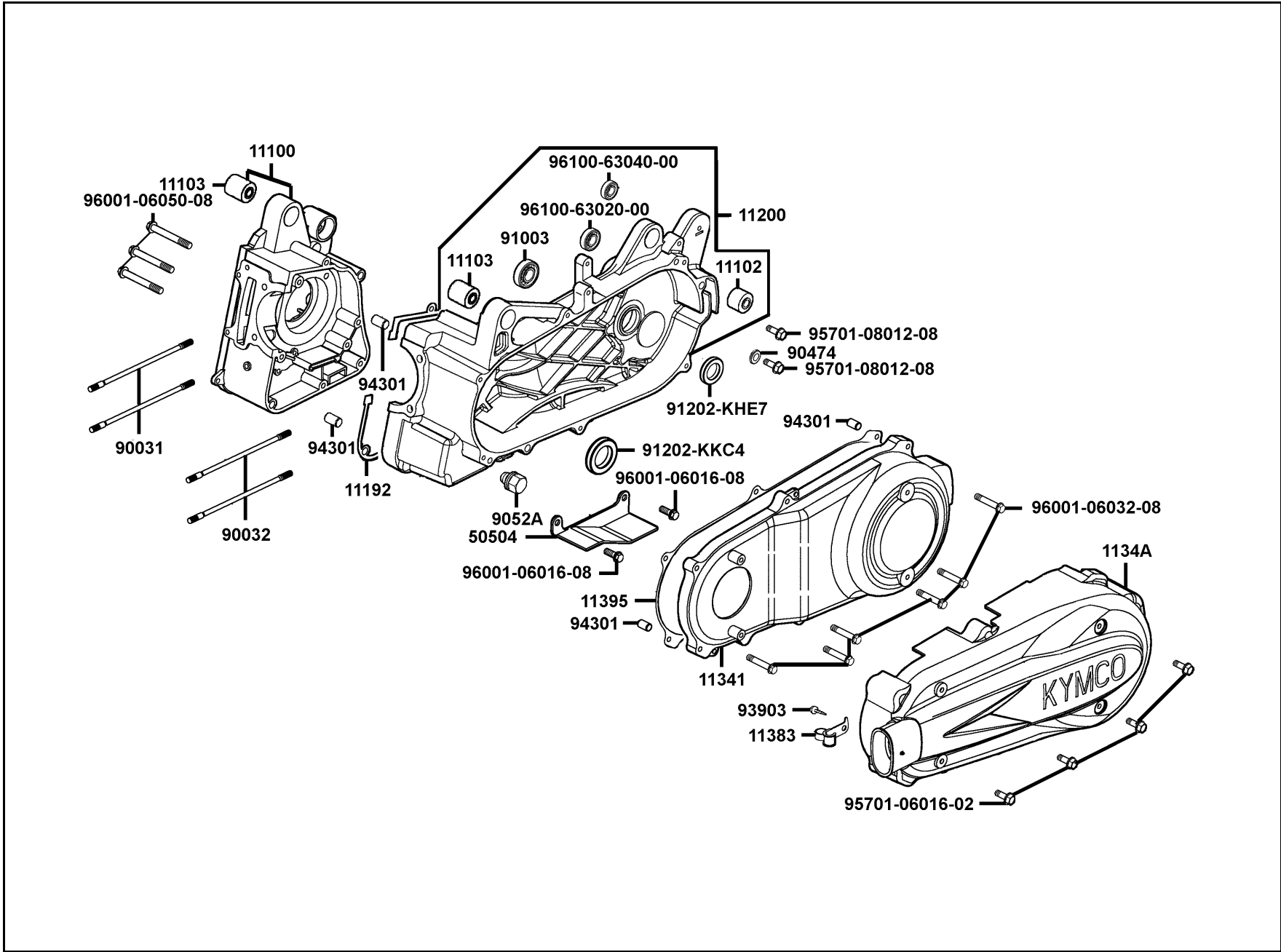

E 1

販賣記號 Sales mark	項目 Ref no	零件號碼 Part no	版數 Ver	英文名稱 Description	中文名稱 Chinese	需要用量 Regd no	參考價 Ref Price
		95701-08012-08	0	BOLT FLANGE 8*12	螺絲 8*12	2	
		96001-06016-08	0	BOLT FLANGE SH 6*16	螺絲 6*16	2	
		96001-06032-08	0	BOLT FLANGE SH 6*32	螺絲 6*32	6	
		96001-06050-08	0	BOLT FLANGE 6*50	螺絲 6*50	3	
		96100-63020-00	0	BRG BALL RADIAL 6302	軸承 6302	1	
		96100-63040-00	1	BRG BALL RADIAL 6304	軸承 6304	1	

E 2 Cylinder Head Cover ● Cylinder Head

汽缸頭蓋 ● 汽缸頭

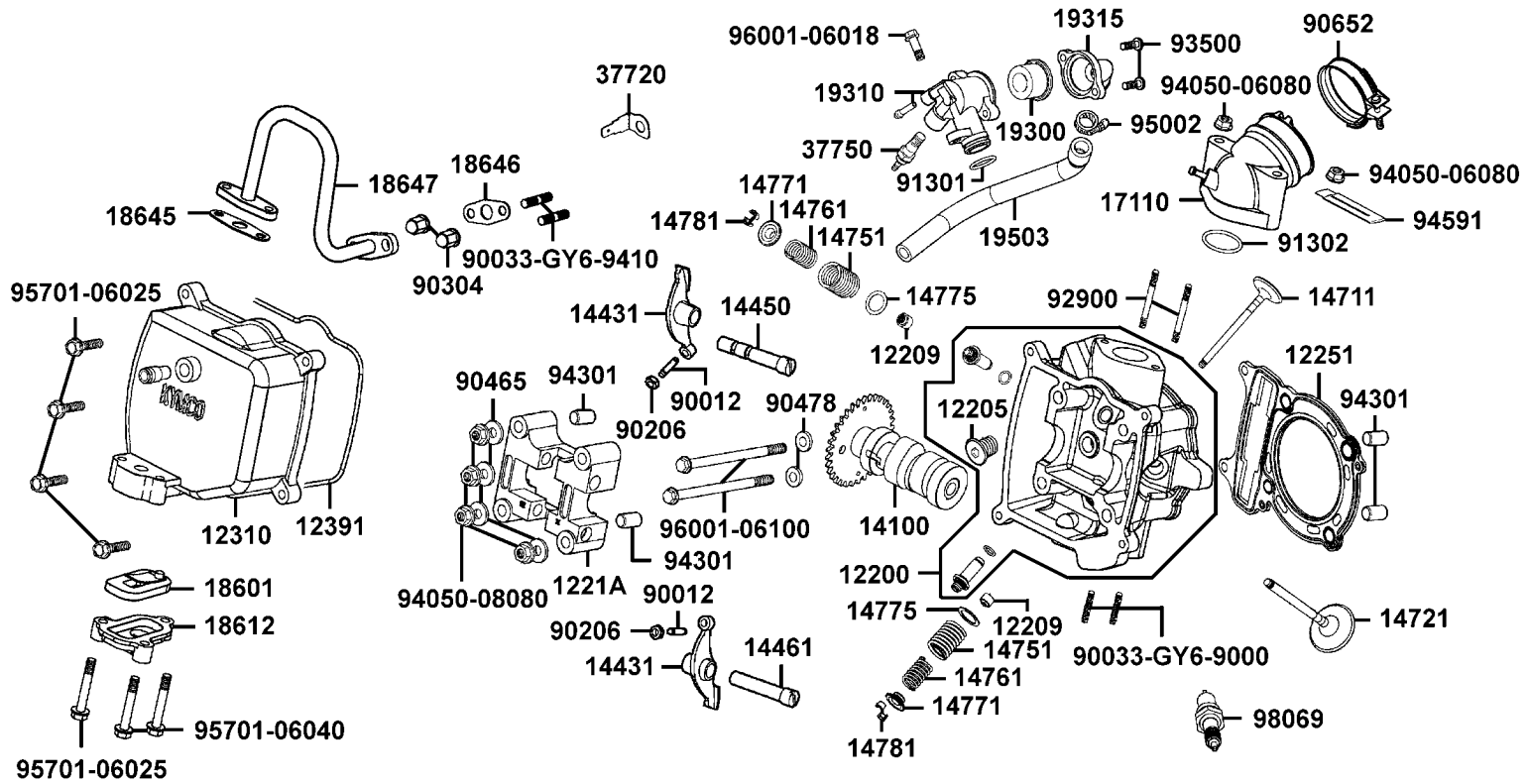

販賣記號 Sales mark	項目 Ref no	零件號碼 Part no	版數 Ver	英文名稱 Description	中文名稱 Chinese	需要用量 Regd no	參考價 Ref Price
		12200-KHE7-900	0	HEAD COMP CYLN	汽缸頭	1	
		12205-KE8-3010	0	BOLT SEALING 12MM	封閉螺栓	1	
		12209-GB4-6820-M1	0	SEAL VALVE STEM	門閥徑封	2	
		1221A-KHE7-9000	0	HOLDER COMP CAM SHAFT	凸輪軸固定座	1	
		12251-KHE7-9010	0	GASKET CYLINDER HEAD	汽缸頭墊片	1	
		12310-KHE7-E000	0	COVER COMP CYLN HEAD	汽缸頭蓋	1	
		12391-KHE7-9000	0	GASKET HEAD COVER	汽缸頭蓋墊圈	1	
		14100-KHE7-220	0	SHAFT COMP CAM	凸輪軸	1	
		14431-KHE7-9000	0	ARM VALVE ROCKER	門閥搖臂	2	
		14450-KBE-9000	0	SHAFT COMP IN ROCKER ARM	進氣閥搖臂軸	1	
		14461-KHE7-9000	0	SHAFT EX ROCKER	排氣閥搖臂軸	1	
		14711-KHE7-9000	0	VALVE INLET	進氣門閥	1	
		14721-KHE7-9000	1	VALVE EXHAUST	排氣門閥	1	
		14751-KHE7-9000	0	SPG VALVE OUTER	門閥外彈簧	2	
		14761-KHE7-9000	0	SPG VALVE INNER	門閥內彈簧	2	
		14771-GB4-6800	2	RETAINER VALVE SPRING	閥門彈簧保持器	2	
		14775-MA6-0000	0	SEAT VALVE SPG OUTER	門閥彈簧外座	2	
		14781-MA6-0000-M1	0	COTTER VALVE	閥門鎖扣	4	
		17110-KHE7-900	0	PIPE COMP INLET	進氣管	1	
		18601-MJ1-7900	1	REED VALVE COMP	簧片單向閥	1	

E 2

販賣記號 Sales mark	項目 Ref no	零件號碼 Part no	版數 Ver	英文名稱 Description	中文名稱 Chinese	需要用量 Regd no	參考價 Ref Price
		18612-GY6-9400	0	COVER REED VALVE	簧片單向閥蓋	1	
		18645-GY6-9400	0	GSKT A/I PIPE	通氣管墊片	1	
		18646-GY6-9400	0	GAKT A/I PIPE	通氣管墊片	1	
		18647-KHE7-900	0	PIPE COMP AIR	通氣鐵管	1	
		19300-KE1-0030-M1	1	THERMOSTAT ASSY	恆溫器	1	
		19310-KHE7-9000	0	CASE COMP THERMOSTAT	恆溫器室	1	
		19315-KHE7-9000	0	COVER THERMOSTAT	恆溫器蓋	1	
		19503-KHE7-900	1	HOSE C WATER	冷卻水管	1	
		37720-KGB5-9000	0	EARTH TERMINAL THERMO	恆溫器座	1	
		37750-PC1-0050	0	THERMO UNIT ASSY	自動控溫器	1	
		90012-333-0010	0	SCREW TAPPET ADJUSTING	樞軸調整螺絲	2	
		90033-GY6-9000	0	BOLT STUD 8*32	螺絲 8*32	2	
		90033-GY6-9410	0	BOLT STUD 6*16	特殊螺絲 8*32	2	
		90206-001-0010	0	NUT TAPPET ADJUSTING	挺桿調整螺帽	2	
		90304-438-0000	2	NUT HEX CAP 6MM	螺帽 6MM	2	
		90465-MC4-0010	0	WASHER 8MM	華司 8MM	4	
		90478-700-0010	0	WASHER A 6MM	華司 6MM	2	
		90652-GY6-9010	0	BAND 49 AIR/C CONNECTING TUBE	連接管固定帶	1	
		91301-KHE7-9000	0	O-RING 17.8*1.9	O環 17.8*1.9	1	
		91302-200-0010	0	O-RING 33.5*3	O環 33.5*3	1	

E 2

E 2 Cylinder Head Cover ● Cylinder Head

汽缸頭蓋 ● 汽缸頭

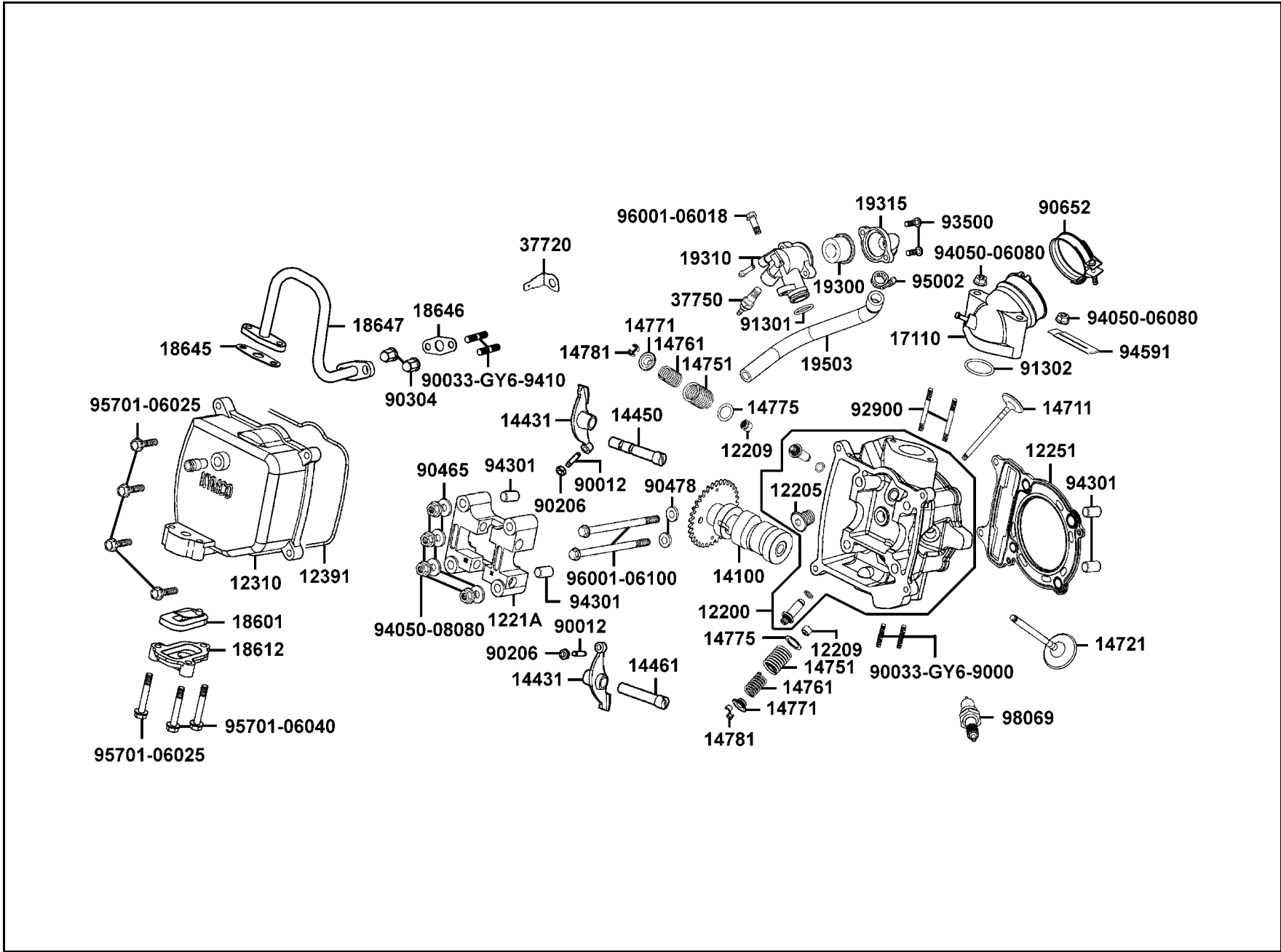

販賣記號 Sales mark	項目 Ref no	零件號碼 Part no	版數 Ver	英 文 名 稱 Description	中 文 名 稱 Chinese	需要用量 Regd no	參考價 Ref Price
		92900-06050-0B	0	BOLT STUD II 6*50	雙頭螺絲 6*50	2	
		93500-05016-0H	0	SCREW PAN 5*16	螺絲 5*16	2	
		94050-06080	0	NUT FLANGE 6MM	特殊螺帽 6MM	2	
		94050-08080	0	NUT FLANGE 8MM	螺帽 8MM	4	
		94301-10160	0	DOWEL PIN 10*16	定位銷 10*16	4	
		94591-KBF-900	2	CLIP 2*71	配線夾 2*71	1	
		95002-KHE7-9000	0	CLIP WATER HOSE	水管夾	1	
		95701-06025-08	0	BOLT FLANGE 6*25	螺絲 6*25	4	
		95701-06040-08	0	BOLT FLANGE 6*40	螺絲 6*40	2	
		96001-06018-08	0	BOLT FLANGE SH 6*18	螺絲 6*18	1	
		96001-06100-08	0	BOLT FLANGE SH 6*100	特殊螺絲 6*100	2	
		98069-5791R-00	0	SPARK PLUG DPR(7EA-9)	火星塞	1	

E 3 Cylinder●Piston●Crankshaft

汽缸
●
活
塞
●
曲
軸

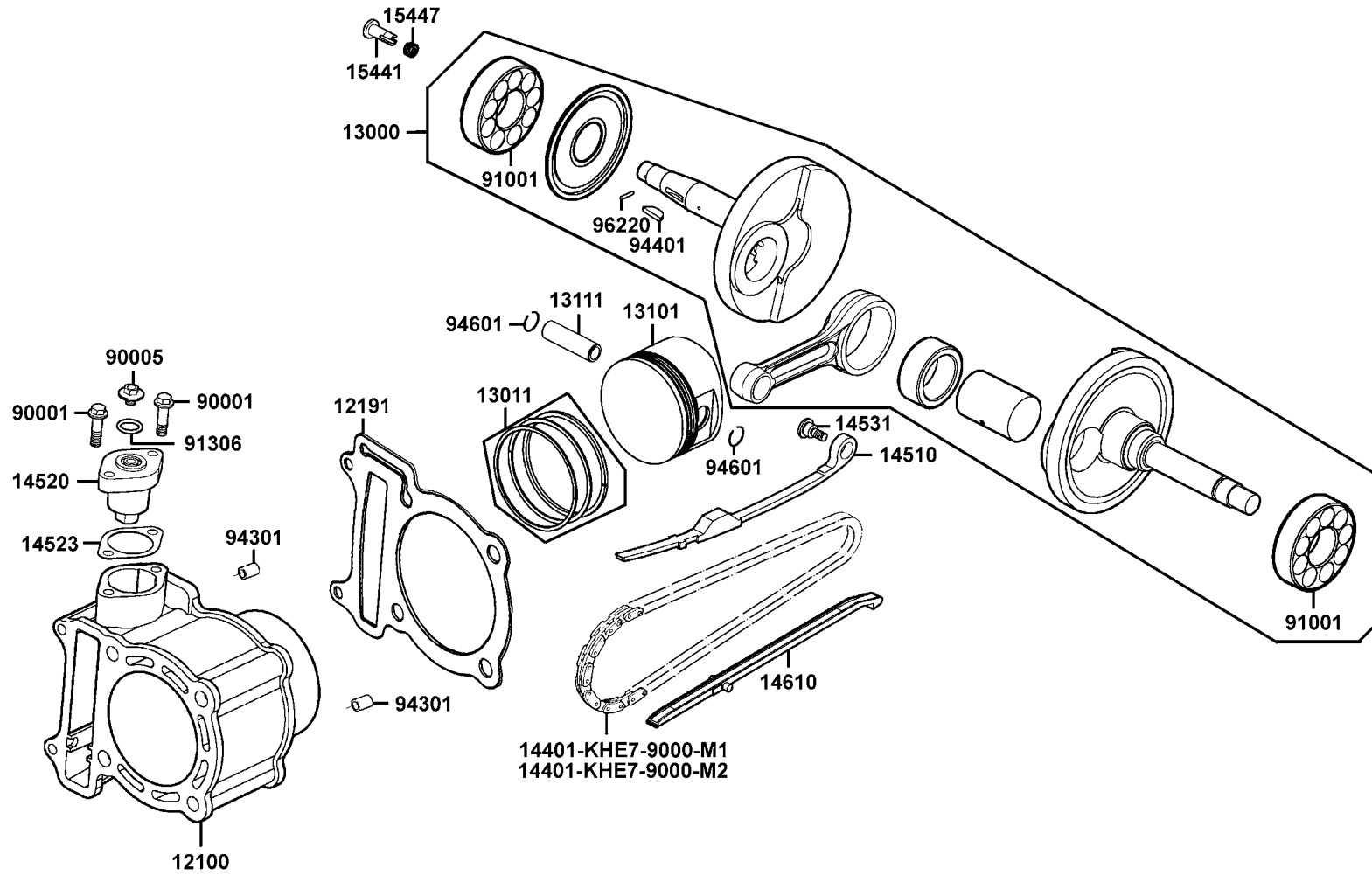

販賣記號 Sales mark	項目 Ref no	零件號碼 Part no	版數 Ver	英文名稱 Description	中文名稱 Chinese	需要用量 Regd no	參考價 Ref Price
		12100-KHE7-9000	3	CYLINDER COMP	汽缸	1	
		12191-KHE7-900	3	GASKET CYLINDER	汽缸墊片	1	
		13000-KHE7-9000	4	CRANK SHAFT COMP	曲軸	1	
		13011-KHE7-9000	0	RING SET PISTON	活塞環	1	
		13101-KHE7-9000	3	PISTON	活塞	1	
		13111-KHE7-9000	1	PIN PISTON	活塞銷	1	
		14401-KHE7-9000-M1	0	CHAIN CAM	凸輪軸驅動鏈條	1	
		14401-KHE7-9000-M2	0	CHAIN CAM	凸輪軸驅動鏈條	1	
		14510-KHE7-9000	0	TENSIONER CAM CHAIN	凸輪軸內鏈條拉力桿	1	
		14520-GY6-90A	1	LIFTER ASSY TENSIONER	內鏈條調整器	1	
		14523-GY6-9000	0	GASKET TENSIONER LIFTER @A	內鏈條調整器墊片	1	
		14531-KHE7-9000	0	PIVOT CAM CHAIN TENSIONER	拉力桿螺絲	1	
		14610-KHE7-9000	0	GUIDE COMP CAM CHAIN	鏈條導件	1	
		15441-149-0010	0	OIL THROUGH	通油器	1	
		15447-149-0010	0	SPG OIL THROUGH	通油器彈簧	1	
		90001-GHB-6610	0	BOLT FLANGE SHF 6*22	螺絲 6*22	2	
		90005-KEC8-9000	1	BOLT SPECIAL 6*6	特殊螺絲 6*6	1	
		91001-KHE7-900	0	BRG BALL RADIAL	軸承	2	
		91306-105-6910	0	O-RING 1.5*9.5	O環 1.5*9.5	1	
		94301-10160	0	DOWEL PIN 10*16	定位銷 10*16	2	

E 3 Cylinder●Piston●Crankshaft

汽缸
●
活塞
●
曲軸

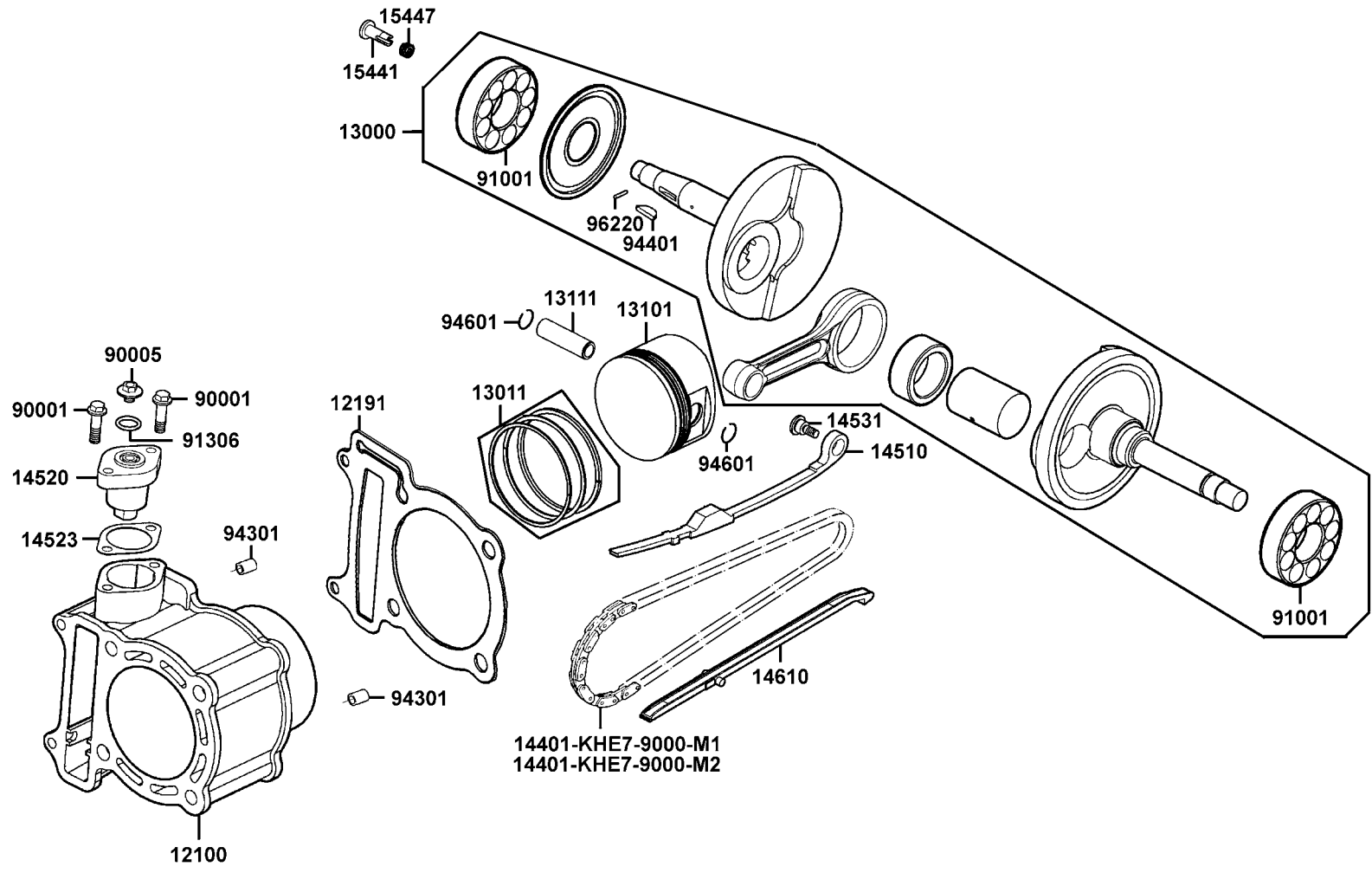

販賣記號 Sales mark	項目 Ref no	零件號碼 Part no	版數 Ver	英 文 名 稱 Description	中 文 名 稱 Chinese	需要用量 Regd no	參考價 Ref Price
		94401-25140-M1	0	WOODRUFF KEY 25*14	固定鍵 25*14	1	
		94601-17000	0	CLIP PISTON PIN 17MM	活塞銷環夾 17MM	2	
		96220-20118	0	ROLLER 2*11.8	滾子 2*11.8	1	

E 4 Right Crankcase Cover ● Water Pump

右曲軸箱蓋 ● 水泵

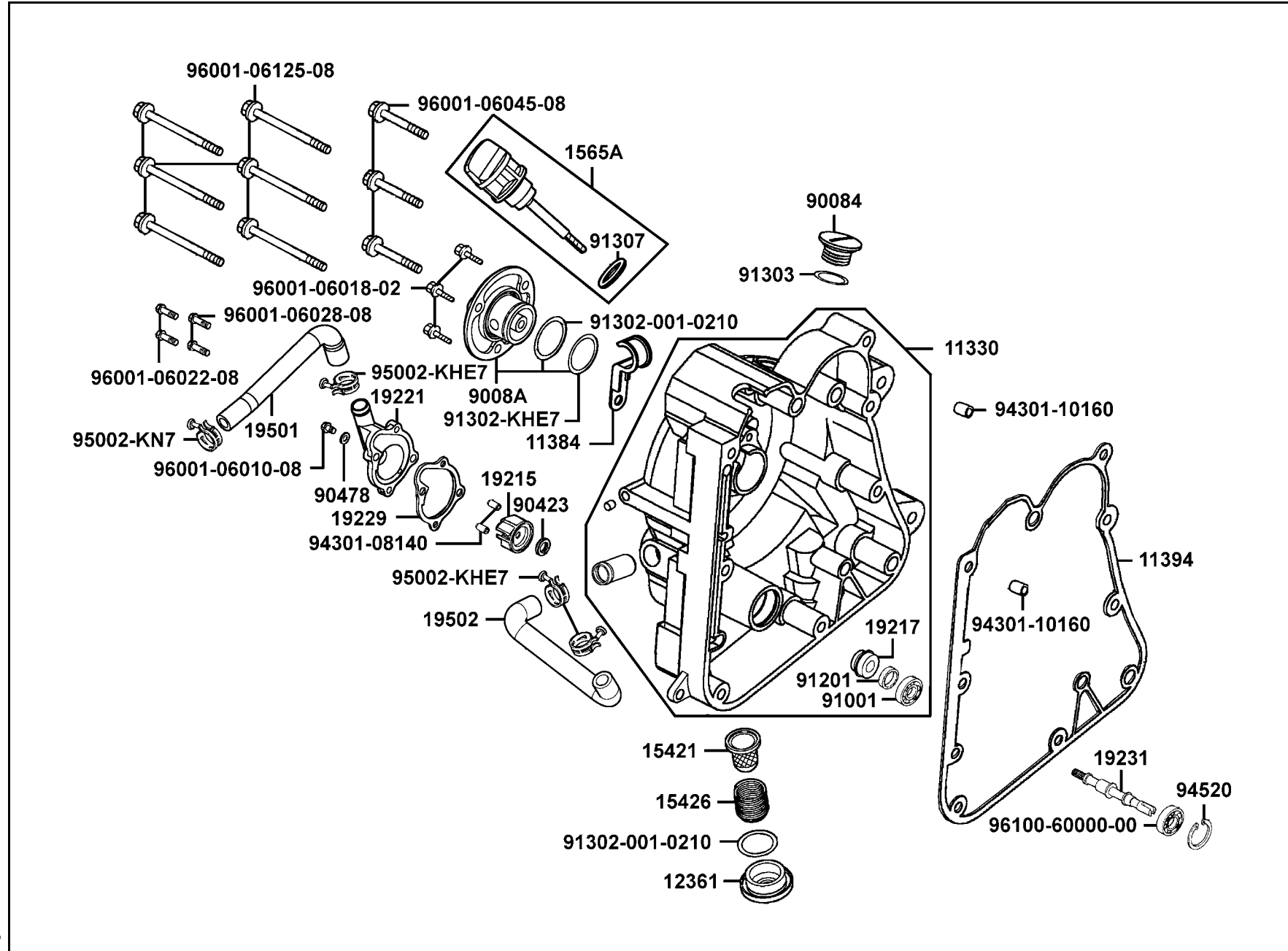

販賣記號 Sales mark	項目 Ref no	零件號碼 Part no	版數 Ver	英文名稱 Description	中文名稱 Chinese	需要用量 Regd no	參考價 Ref Price
		11330-KHE7-900	5	COVER COMP RIGHT	右曲軸箱蓋	1	
		11384-KHE7-9000	1	CLAMPER A RR BRK HOSE	後煞車油管夾 A	1	
		11394-KHE7-9000	1	GASKET R COVER @ A	右曲軸箱蓋墊片 A	1	
		12361-GY6-9010	0	HOLE CAP TAPPET ADJUSTING	調節螺帽	1	
		15421-107-0000	1	SCREEN OIL FILTER	濾油網	1	
		15426-GE1-9200	0	SPG OIL FILTER SCREEN	濾油網彈簧	1	
		1565A-KBE-9000	0	GAUGE OIL LEVEL ASSY	機油尺組	1	
		19215-KHE7-9000	0	IMPELLER WATER PUMP	水泵葉輪	1	
		19217-657-0240	0	SEAL MECHANICAL	機械油封	1	
		19221-KHE7-9000	0	COVER WATER PUMP	水泵蓋	1	
		19229-KHE7-9000	0	GASKET WATER PUMP	水泵墊片	1	
		19231-KJ9-0110	0	SHAFT WATER PUMP	水泵樞軸	1	
		19501-KHE7-9000	0	HOSE A WATER	冷卻水管 A	1	
		19502-KHE7-9000	0	HOSE B WATER	冷卻水管 B	1	
		90084-428-0010	0	CAP A.C.G	A.C.G.蓋	1	
		9008A-KHE7-9000	0	CAP ASSY R COVER	蓋組	1	
		90423-KJ9-0010	0	WASHER 7.2*13*1.2	華司 7.2*13*1.2	1	
		90478-700-0010	0	WASHER A 6MM	華司 6MM	1	
		91001-KJ9-0060	0	BEARING BALL RADIAL 6901	軸承 6901	1	
		91201-KJ9-0040	0	OIL SEAL 12*20*4	油封 12*20*4	1	

E 4 Right Crankcase Cover ● Water Pump

右曲軸箱蓋 ● 水泵

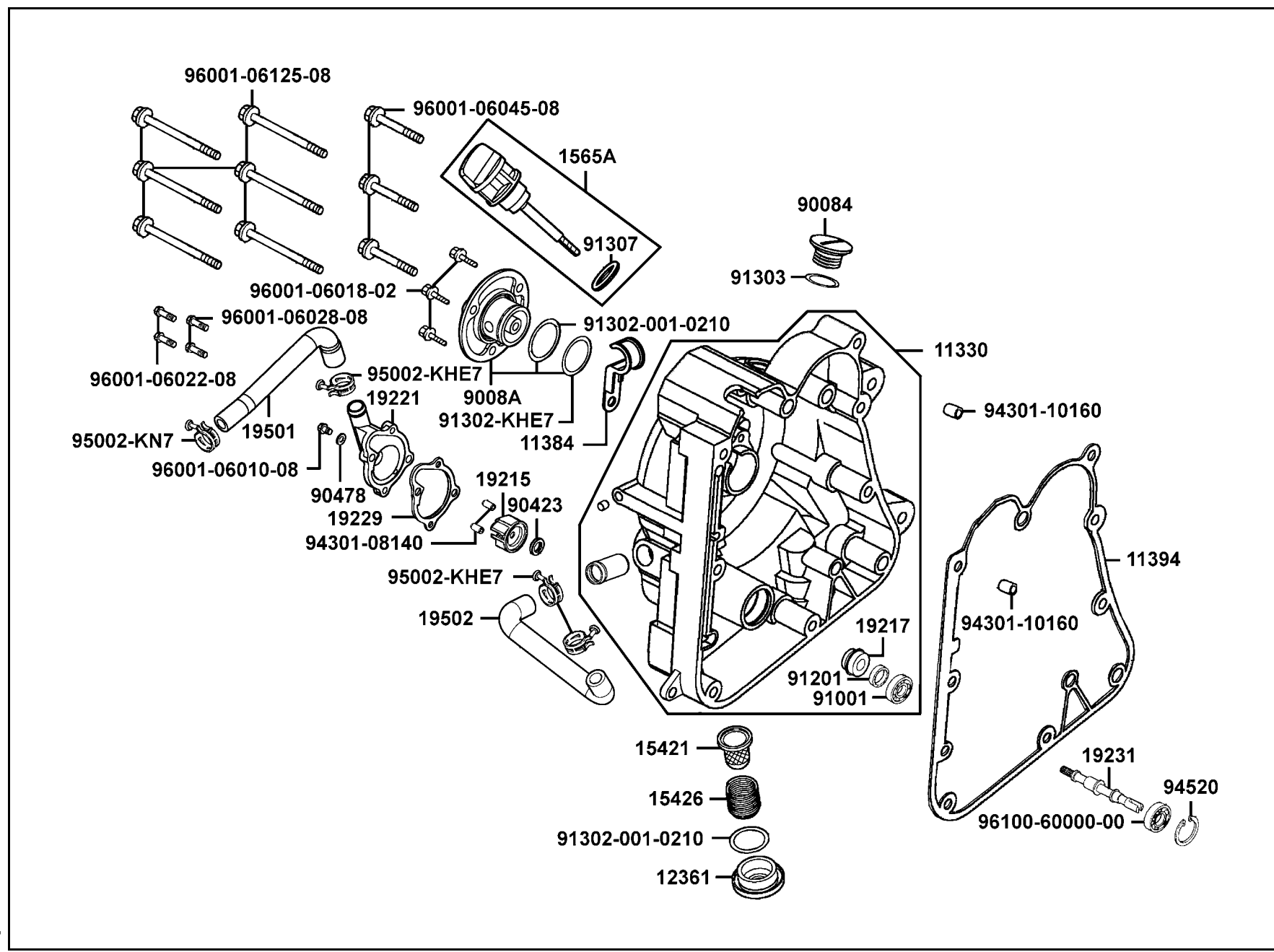

販賣記號 Sales mark	項目 Ref no	零件號碼 Part no	版數 Ver	英文名稱 Description	中文名稱 Chinese	需要用量 Regd no	參考價 Ref Price
		91302-001-0210	0	O-RING 30.8M/M	O環 30.8MM	2	
		91302-KHE7-9000	0	O-RING 27.4*2.1MM	O環 27.4*2.1MM	1	
		91303-377-0010	0	O-RING 13.8*2.5	O環 13.8*2.5	1	
		91307-035-0010	0	O-RING 18*3	O環 18*3	1	
		94301-08140	0	DOWEL PIN 8*14	定位銷 8*14	2	
		94301-10160	0	DOWEL PIN 10*16	定位銷 10*16	2	
		94520-26000	0	CIR CLIP INTERAL 26MM	內環夾 26MM	1	
		95002-KHE7-9000	0	CLIP WATER HOSE	水管夾	3	
		95002-KN7-9100	1	CLIP TUBE	管夾	1	
		96001-06010-08	0	BOLT FLANGE SH 6*10	螺絲 6*10	1	
		96001-06018-02	0	BOLT FLANGE SH 6*18	螺絲 6*18	3	
		96001-06022-08	0	BOLT FLANGE SH 6*22	螺絲 6*22	2	
		96001-06028-08	0	BOLT FLANGE SH 6*28	螺絲 6*28	2	
		96001-06045-08	0	BOLT FLANGE SH 6*45	螺絲 6*45	3	
		96001-06125-08	0	BOLT FLANGE SH 6*125	螺絲 6*125	6	
		96100-60000-00	0	BEARING BALL RADIAL 6000	軸承 6000	1	

E 5 Pulley

皮帶輪

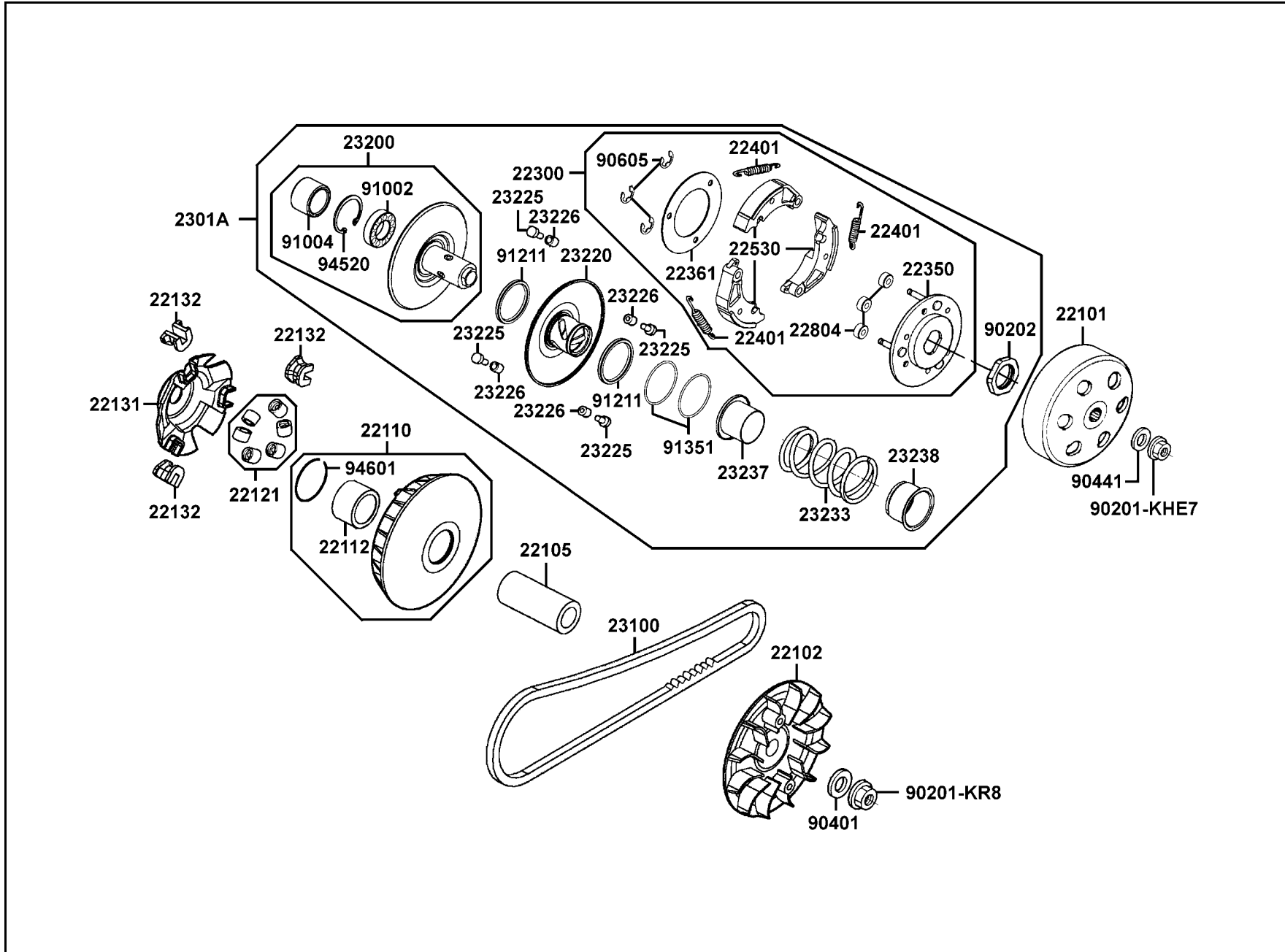

販賣記號 Sales mark	項目 Ref no	零件號碼 Part no	版數 Ver	英文名稱 Description	中文名稱 Chinese	需要用量 Regd no	參考價 Ref Price
		22101-KHE7-9000	0	OUTER CLUTCH	離合器外套	1	
		22102-KHE7-900	1	FACE DRIVE	驅動皮帶扇葉盤	1	
		22105-KHE7-900	1	BOSS DRIVE FACE	襯套	1	
		22110-KHE7-900	2	FACE COMP MOVABLE DRIVE	滑動式驅動盤組	1	
		22112-KHE7-900	1	BUSH 27*33*37	襯套 27*33*37	1	
		22121-KHE7-9000-M1	0	ROLLER COMP WEIGHT	配重滾子	6	
		22131-KHE7-9000	0	PLATE RAMP	斜坡板	1	
		22132-KHE7-9000	2	PIECE SLIDE	斜坡板邊件	3	
		22300-KHE7-9000	0	PLATE ASSY DRIVE	驅動板組	1	
		22350-KHE7-9000	0	PLATE COMP DRIVE	驅動板	1	
		22361-KHE7-9000	0	PLATE CLUTCH SIDE	離合器舉升板	1	
		22401-KHE7-9000	0	SPRING CLUTCH	離合器彈簧	3	
		22530-KHE7-9000	0	WEIGHT CLUTCH	離合器配重	3	
		22804-GB2-0010	0	RUBBER CLUTCH DAMPER	橡皮	3	
		2301A-KHE7-900	5	PULLEY SUB ASSY	從動皮帶輪組	1	
		23100-KHE7-9000	0	BELT DRIVE	驅動皮帶	1	
		23200-KHE7-900	4	FACE ASSY DRIVEN	平面傳動盤組	1	
		23220-KHE7-9000	3	FACE COMP MOVABLE DRIVEN	滑動式從動皮帶盤	1	
		23225-KHE7-9000	0	PIN ROLLER GUIDE	滾導銷	4	
		23226-GC8-0040	0	ROLLER GUIDE	滾子	4	

E 5 Pulley

皮帶輪

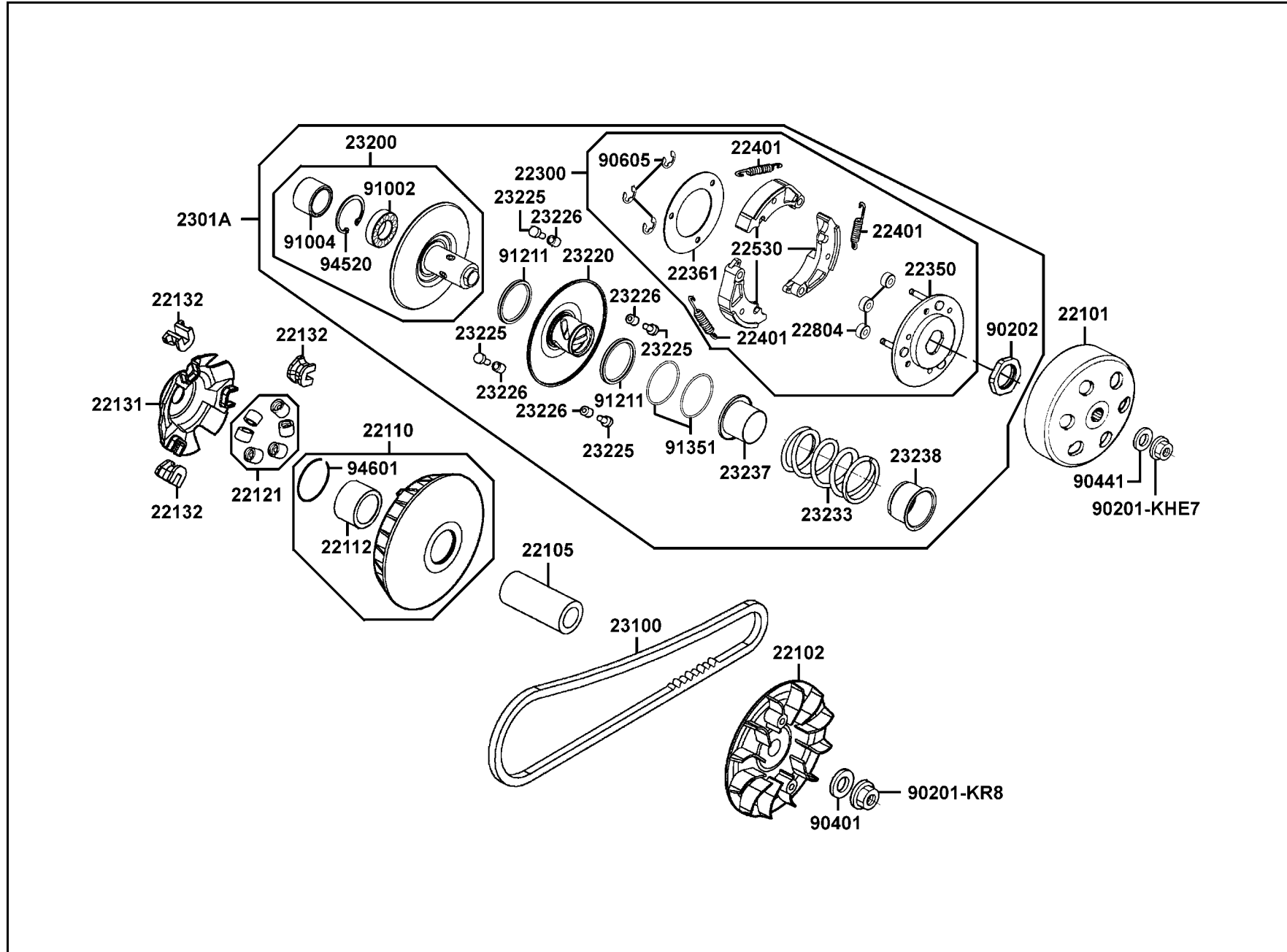

販賣記號 Sales mark	項目 Ref no	零件號碼 Part no	版數 Ver	英文名稱 Description	中文名稱 Chinese	需要用量 Regd no	參考價 Ref Price
		23233-KHE7-9000	0	SPG DRIVEN FACE	驅動彈簧	1	
		23237-KHE7-9000	0	COLLAR SEAL	套筒	1	
		23238-KHE7-9000	0	COLLAR SPG	套筒	1	
		90201-KHE7-9000	0	NUT C FLANGE M12	螺帽 12MM	1	
		90201-KR8-7520-M1	0	NUT FLANGE 14MM	螺帽 14MM	1	
		90202-187-0010	0	NUT SPECIAL 28MM	螺帽 28MM	1	
		90401-KJ9-0010	0	WASHER THRUST 14*28*2	華司 14*28*2	1	
		90441-GY6-9410	0	WASHER 12.2*29*2.5	華司 12.2*29*2.5	1	
		90605-166-7210	0	CIR CLIP 7MM	環夾 7MM	3	
		91002-GA7-70A	0	BRG BALL RADIAL 6902U	軸承 6902U	1	
		91004-KHE7-900	1	BRG NDL 22*29*18	軸承 22*29*18	1	
		91211-KHE7-9000	0	SEAL DRIVEN FACE	驅動油封	2	
		91351-KHE7-9000	0	O-RING PINION CAP	O環	2	
		94520-28000	0	CIR CLIP IN 28	內環夾 28MM	1	
		94601-33000	0	CLIP PISTON PIN 33MM	夾子 33MM	1	

E 6 Starting Motor ● Generator

起
動
馬
達
●
發
電
機

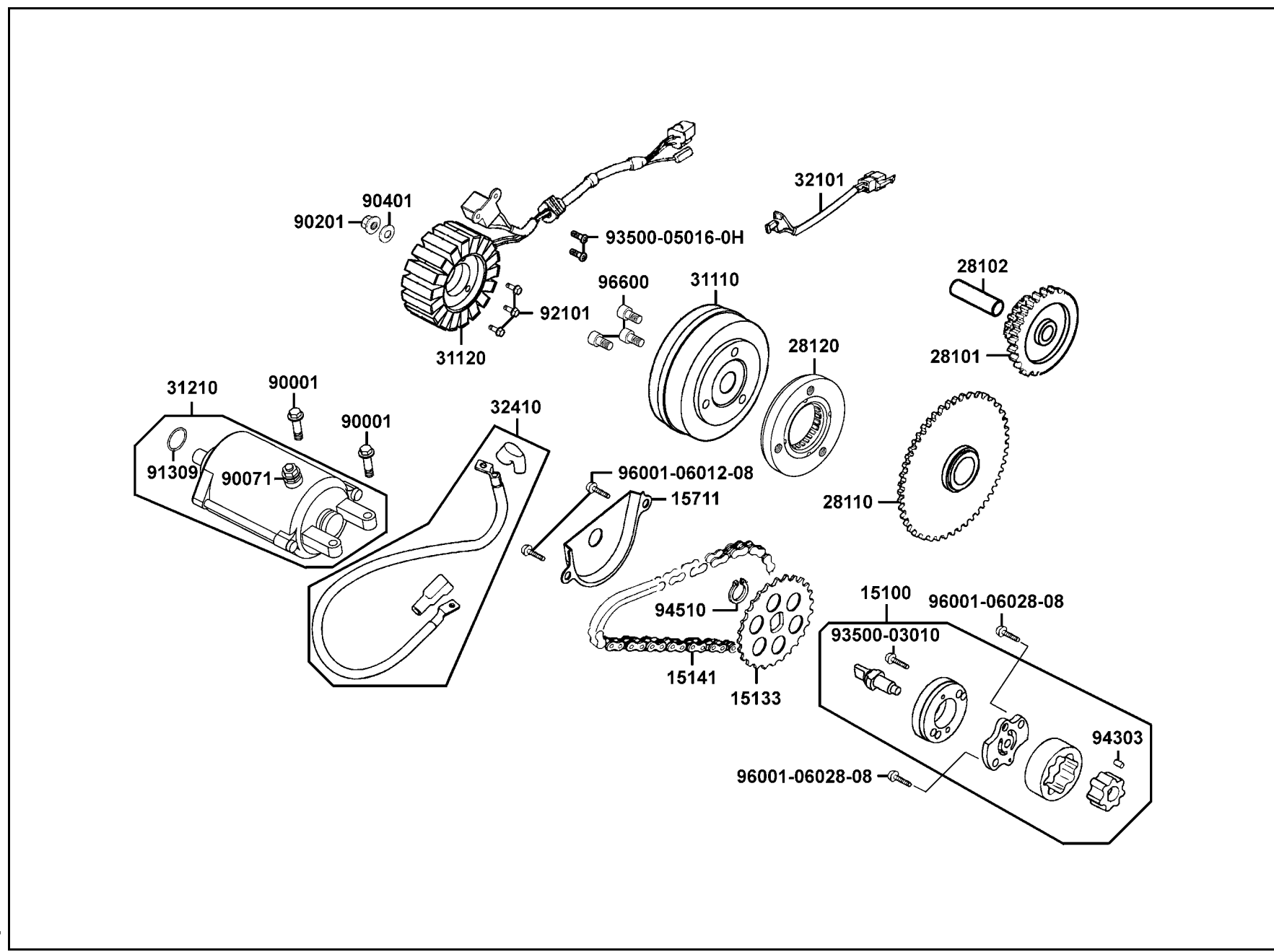

販賣記號 Sales mark	項目 Ref no	零件號碼 Part no	版數 Ver	英文名稱 Description	中文名稱 Chinese	需要用量 Regd no	參考價 Ref Price
		15100-KBE-9000	0	PUMP ASSY OIL	油泵	1	
		15133-KM1-0010	0	SPROCKET OIL PUMP DRIVE	機油泵驅動齒輪	1	
		15141-KJ9-0040	0	CHAIN OIL PUMP	機油泵驅動鏈條	1	
		15711-KHE7-9000	0	SEPARATER OIL	機油分隔板	1	
		28101-KHE7-9000	0	GEAR STARTER REDUCTION	起動減速齒輪	1	
		28102-KHE7-9000	0	SHAFT STARTER REDUCTION GEAR	起動減速齒輪軸	1	
		28110-KHE7-9000	2	GEAR COMP STARTING CLUTCH	起動齒輪	1	
		28120-KHE7-E000	0	ONE WAY CLUTCH	離合器外套	1	
		31110-KHE7-9000-M1	0	FLYWHEEL COMP	飛輪	1	
		31120-KKC4-90A	1	STATOR COMP	轉子線圈	1	
		31210-KHE7-9000-M1	1	MOTOR UNIT STARTER	起動馬達組	1	
		32101-KHE7-E000	0	SUB CORD	配線	1	
		32410-KKC4-900	1	CABLE STARTER MOTOR	起動馬達配線	1	
		90001-GHB-6610	0	BOLT FLANGE SHF 6*22	螺絲 6*22	2	
		90071-MB0-0010	0	NUT WASH 6MM	螺帽 6MM	1	
		90201-KR8-7520-M1	0	NUT FLANGE 14MM	螺帽 14MM	1	
		90401-KJ9-0010	0	WASHER THRUST 14*28*2	華司 14*28*2	1	
		91309-425-0040	0	O-RING 24.4*3.1	O環 24.4*3.1	1	
		92101-05032-0H	0	BOLT HEX 5*32	螺絲 5*32	3	
		93500-03010-1A	0	SCREW PAN 3*10	螺絲 3*10	1	

E 6 Starting Motor ● Generator

起
動
馬
達
●
發
電
機

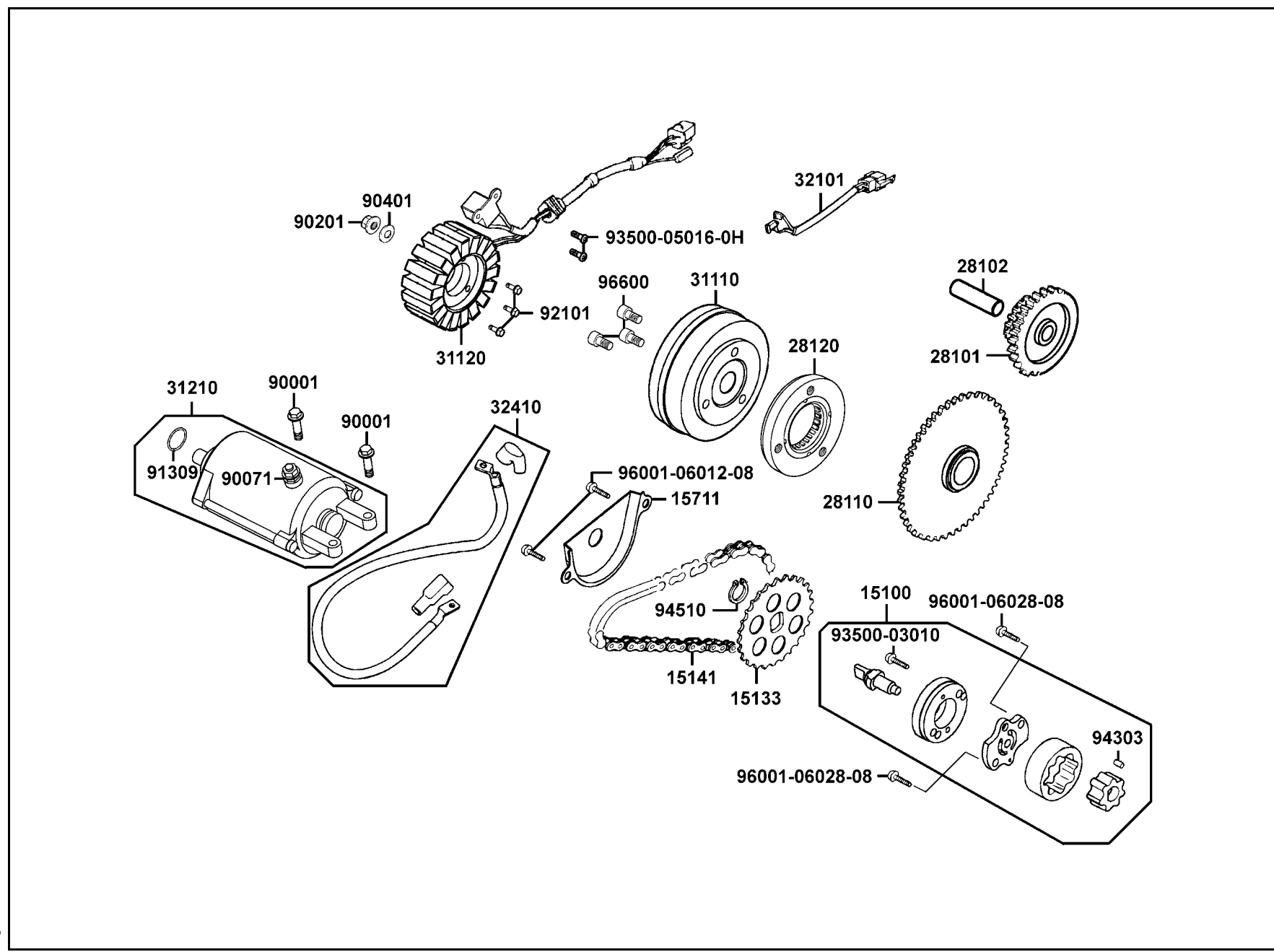

E 6

販賣記號 Sales mark	項目 Ref no	零件號碼 Part no	版數 Ver	英 文 名 稱 Description	中 文 名 稱 Chinese	需要用量 Regd no	參考價 Ref Price
		93500-05016-0H	0	SCREW PAN 5*16	螺絲 5*16	2	
		94303-04065	0	PIN DOWEL 4*65	定位銷 4*65	1	
		94510-10000	0	CIR CLIP EX 10MM	外環夾 10MM	1	
		96001-06012-08	0	BOLT FLANGE SH 6*12	螺絲 6*12	2	
		96001-06028-08	0	BOLT FLANGE SH 6*28	螺絲 6*28	2	
		96600-08015-10	1	SOCKET BOLT 8*15	螺絲 8*15	3	

E 7 Transmission

傳
動
系

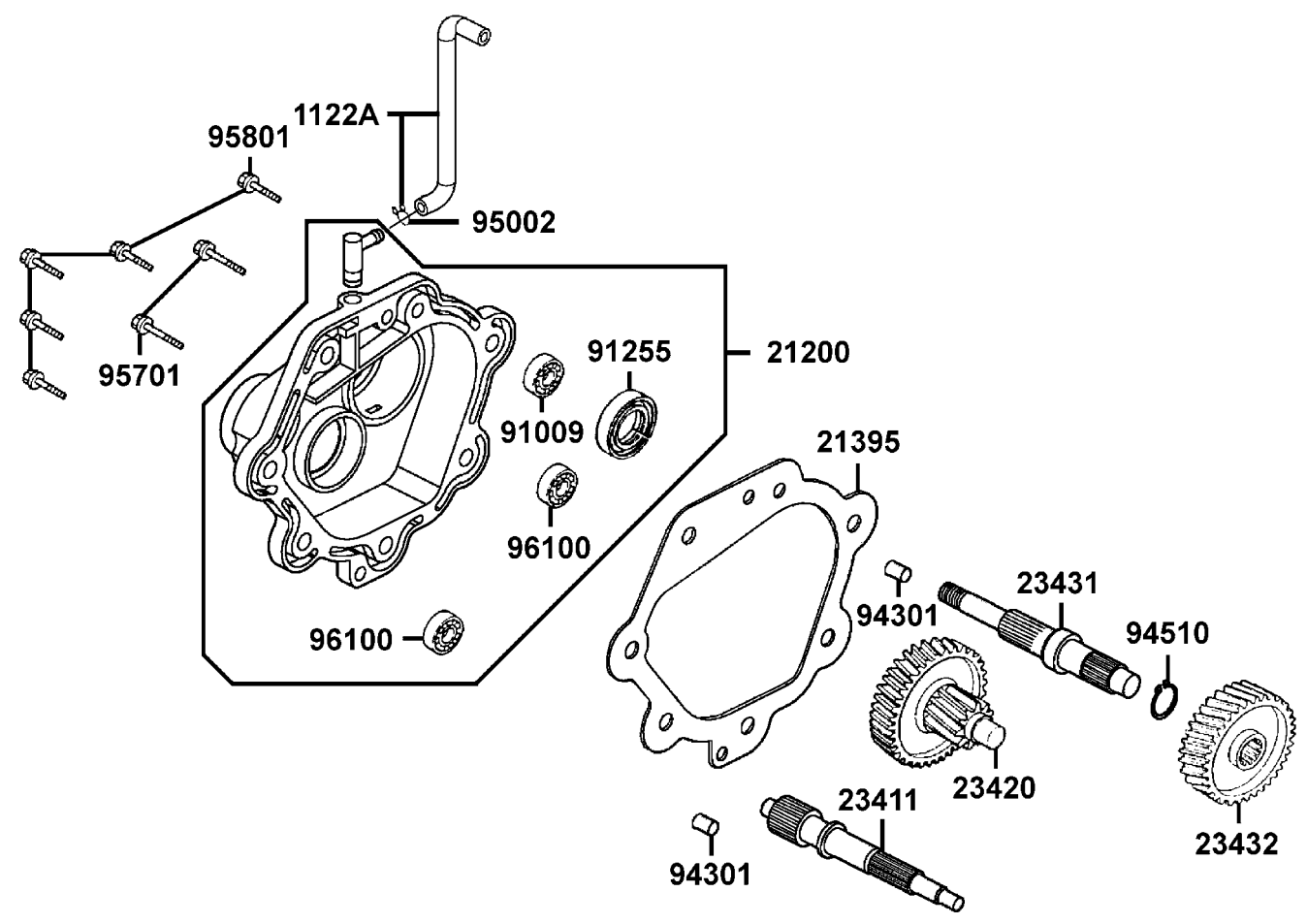

販賣記號 Sales mark	項目 Ref no	零件號碼 Part no	版數 Ver	英文名稱 Description	中文名稱 Chinese	需要用量 Regd no	參考價 Ref Price
		1122A-KKC4-9000	0	TUBE ASSY MISSION BREATHER	通氣管組	1	
		21200-KHE7-3050	0	CASE SET MISSION	主軸箱	1	
		21395-KHE7-9000	0	GASKET MISSION COVER @ A	主軸蓋墊片	1	
		23411-KHE7-900	3	SHAFT DRIVE	驅動軸	1	
		23420-KHE7-910	0	SHAFT COMP COUNTER	副軸組	1	
		23431-KHE7-9000	0	SHAFT FINAL	最終軸	1	
		23432-KHE7-910	0	GEAR FINAL	最終齒輪	1	
		91009-KHE7-9000	0	BRG BALL RADIAL 6205LLU	軸承 6205	1	
		91255-KHE7-9000	0	OIL SEAL 34*52*7	油封 34*52*7	1	
		94301-10160	0	DOWEL PIN 10*16	定位銷 10*16	2	
		94510-25000	0	CIR CLIP EXTERNAL 25	外環夾 25MM	1	
		95002-02080	0	CLIP B8 TUBE	管夾	1	
		95701-08035-08	0	BOLT FLANGE 8*35	螺絲 8*35	2	
		95801-08030-08	0	BOLT FLANGE 8*30	螺絲 8*30	5	
		96100-63020-00	0	BRG BALL RADIAL 6302	軸承 6302	2	

E 8 Carburetor

化油器

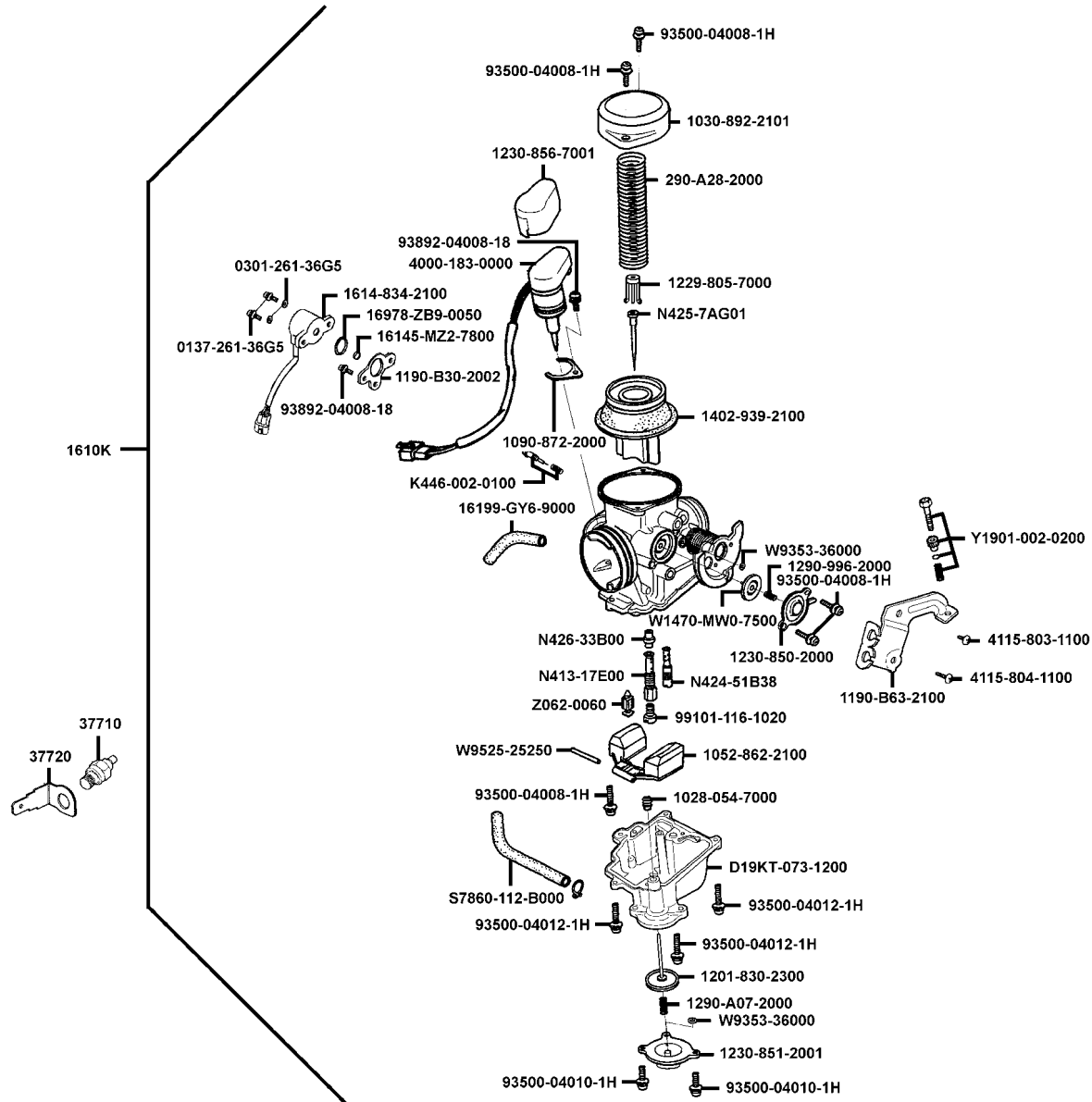

販賣記號 Sales mark	項目 Ref no	零件號碼 Part no	版數 Ver	英 文 名 稱 Description	中 文 名 稱 Chinese	需要用量 Regd no	參考價 Ref Price
		0137-261-36G5	0	SCREW PAN	螺絲	2	
		0301-261-36G5	0	PLAIN WASHER	華司	2	
		1028-054-7000	0	SEALING CAP	護蓋油封	1	
		1030-892-2101	0	TOP SET	真空活塞閥蓋	1	
		1052-862-2100	0	FLOAT COMP	浮筒組	1	
		1090-872-2000	0	SET PLATE	固定板	1	
		1190-B30-2002	0	STAY PLATE	支板	1	
		1190-B63-2100	0	STAY PLATE SET	推動臂支座	1	
		1201-830-2300	1	DIAPHRAGM COMP	泵浦閥	1	
		1229-805-7000	0	VALVE PLATE SET	安全閥固定板	1	
		1230-850-2000	0	COVER	護蓋	1	
		1230-851-2001	0	COVER	護蓋	1	
		1230-856-7001	0	HOLDER CAP	自動起動閥蓋	1	
		1290-996-2000	0	SPG COMPR	彈簧	1	
		1290-A07-2000	0	SPG COMPR	彈簧	1	
		1402-939-2100	0	VACUUM PISTON COMP	真空活塞閥	1	
		1610K-KKC4-E000	2	CARBURETOR ASSY	化油器	1	
		16145-MZ2-7800	0	JOINT COLLAR	套筒	1	
		1614-834-2100	0	THROTTLE SENSOR	節流閥開度感應器	1	
		16199-GY6-9000	0	TUBE SET	通氣管	1	

E 8 Carburetor

化油器

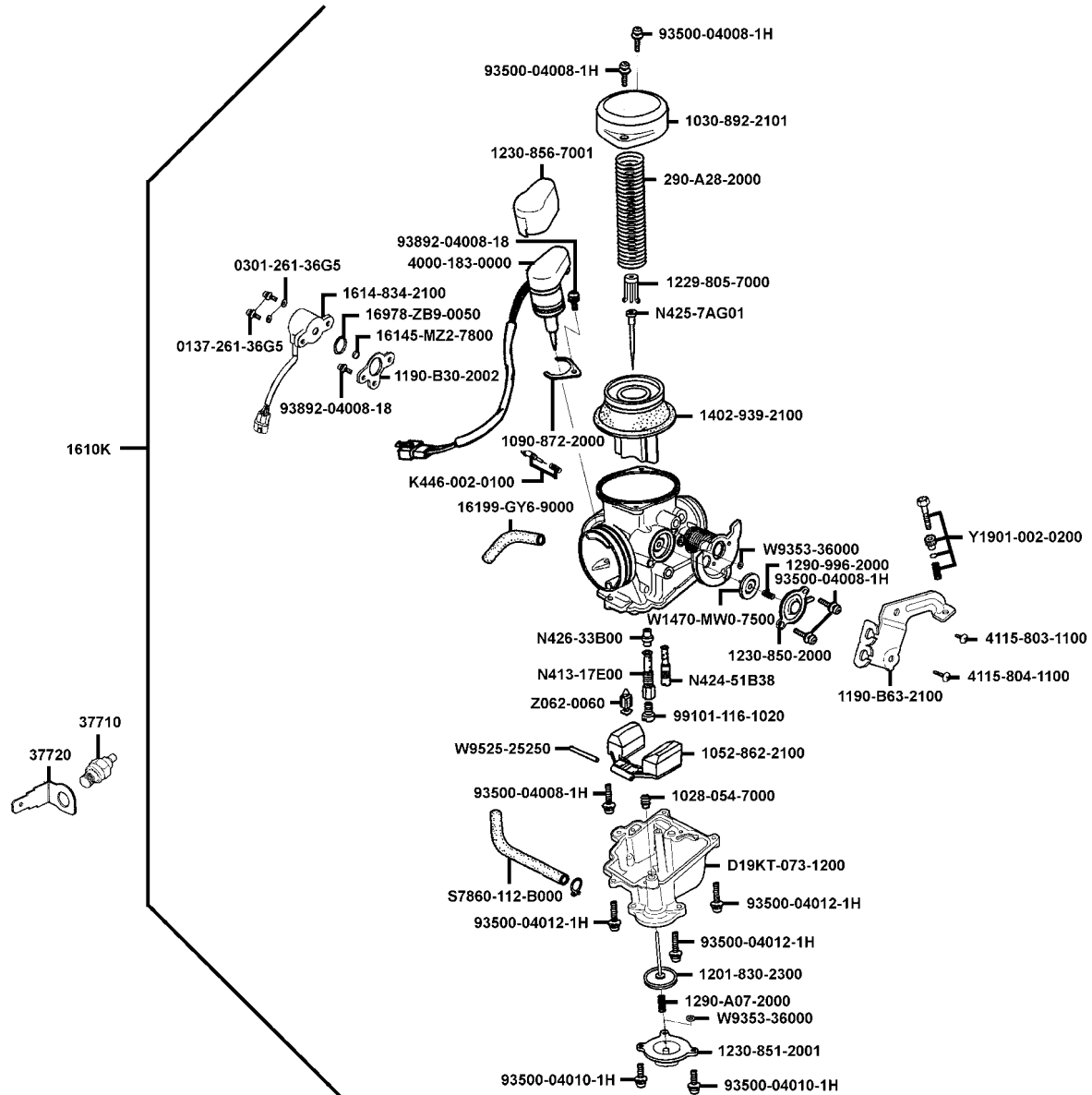

販賣記號 Sales mark	項目 Ref no	零件號碼 Part no	版數 Ver	英文名稱 Description	中文名稱 Chinese	需要用量 Regd no	參考價 Ref Price
		16978-ZB9-0050	0	O-RING	O環	1	
		290-A28-2000	0	SPG COMPR	彈簧	1	
		37710-KGBG-E000	0	HEATER	加熱器	1	
		37720-KGBG-E000	0	EARTH TERMINAL	接地板	1	
		4000-183-0000	0	AUTO BYSTARTER SET	自動旁通器	1	
		4115-803-1100	0	SCREW PAN	螺絲	1	
		4115-804-1100	0	SCREW PAN	螺絲	1	
		93500-04008-1H	0	SCREW PAN	螺絲	5	
		93500-04010-1H	0	SCREW PAN	螺絲	2	
		93500-04012-1H	0	SCREW PAN	螺絲	3	
		93892-04008-18	0	SCREW WASHER	螺絲	2	
		99101-116-1020	0	MAIN JET	主噴油嘴	1	
		D19KT-073-1200	0	FLOAT CHAMBER SET	浮筒室組	1	
		K446-002-0100	0	SCREW SET	螺絲組	1	
		N413-17E00	0	NEEDLE JET HOLDER	油針支座	1	
		N424-51B38	0	SLOW JET	慢速噴油嘴	1	
		N425-7AG01	0	JET NEEDLE COMP	油針	1	
		N426-33B00	0	NEEDLE JET	油針座	1	
		S7860-112-B000	0	TUBE SET	溢流管	1	
		W1470-MW0-7500	0	DIAPHRAGM COMP	阻風閥組	1	

E 8 Carburetor

化油器

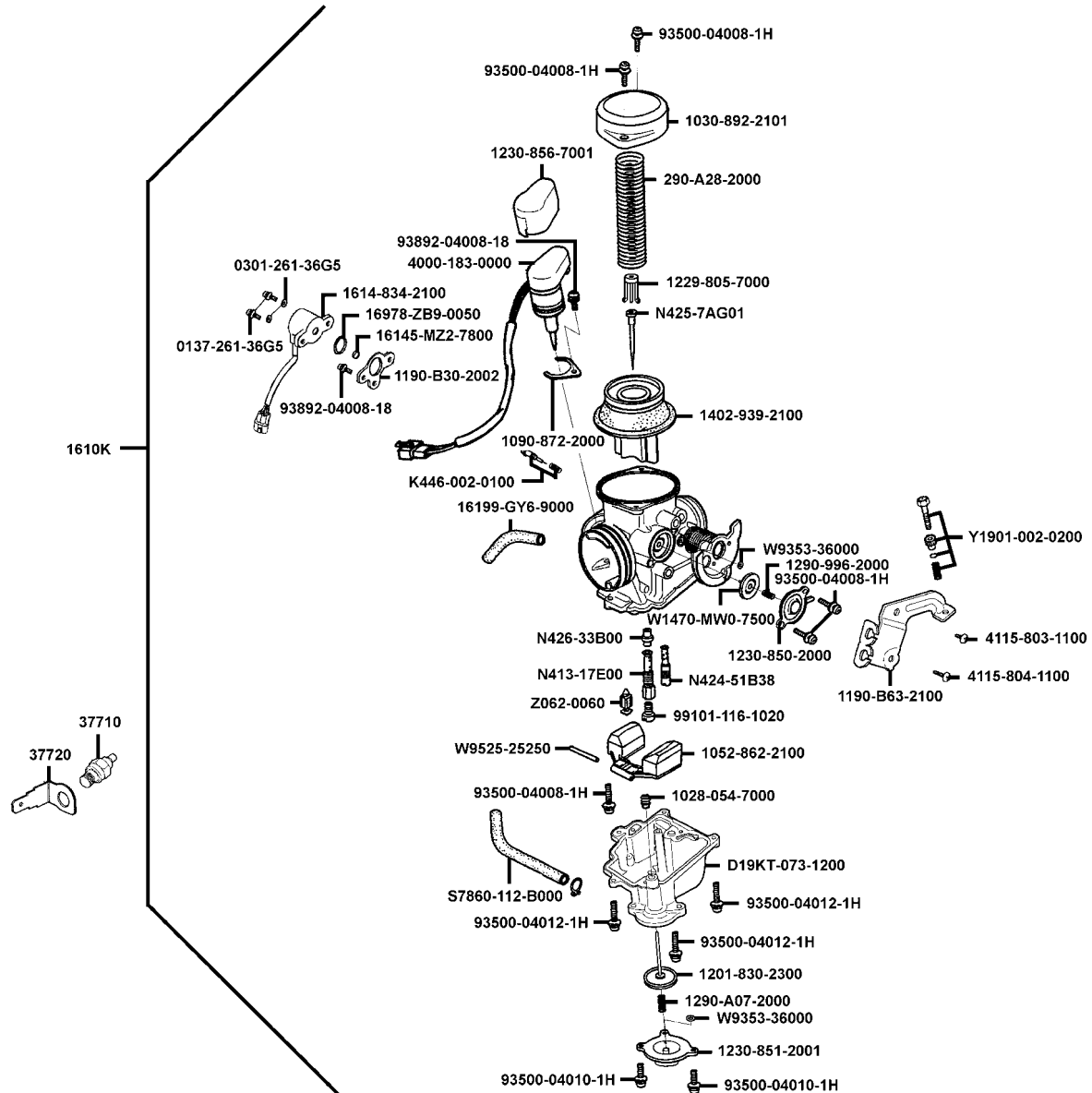

販賣記號 Sales mark	項目 Ref no	零件號碼 Part no	版數 Ver	英 文 名 稱 Description	中 文 名 稱 Chinese	需要用量 Regd no	參考價 Ref Price
		W9353-36000	0	U RING	U形環	2	
		W9525-25250	0	ARM PIN	浮筒閥臂銷	1	
		Y1901-002-0200	0	SCREW SET	螺絲組	1	
		Z062-0060	0	FLOAT VALVE SET	浮筒閥	1	

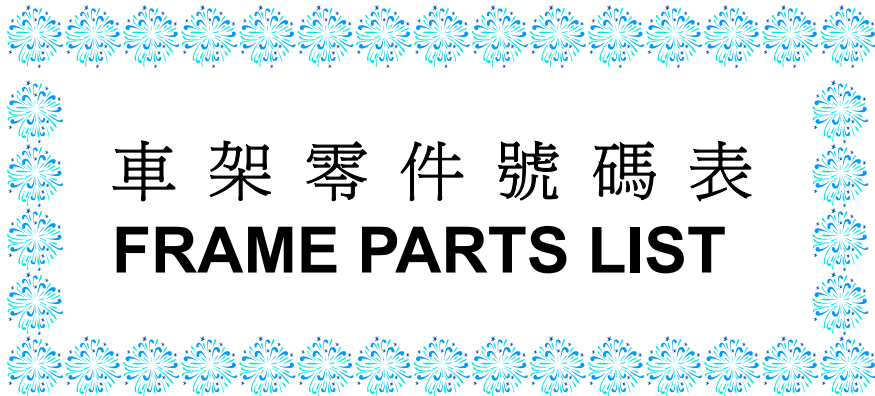

車架零件號碼表
FRAME PARTS LIST

F 1 Head Light

前
燈

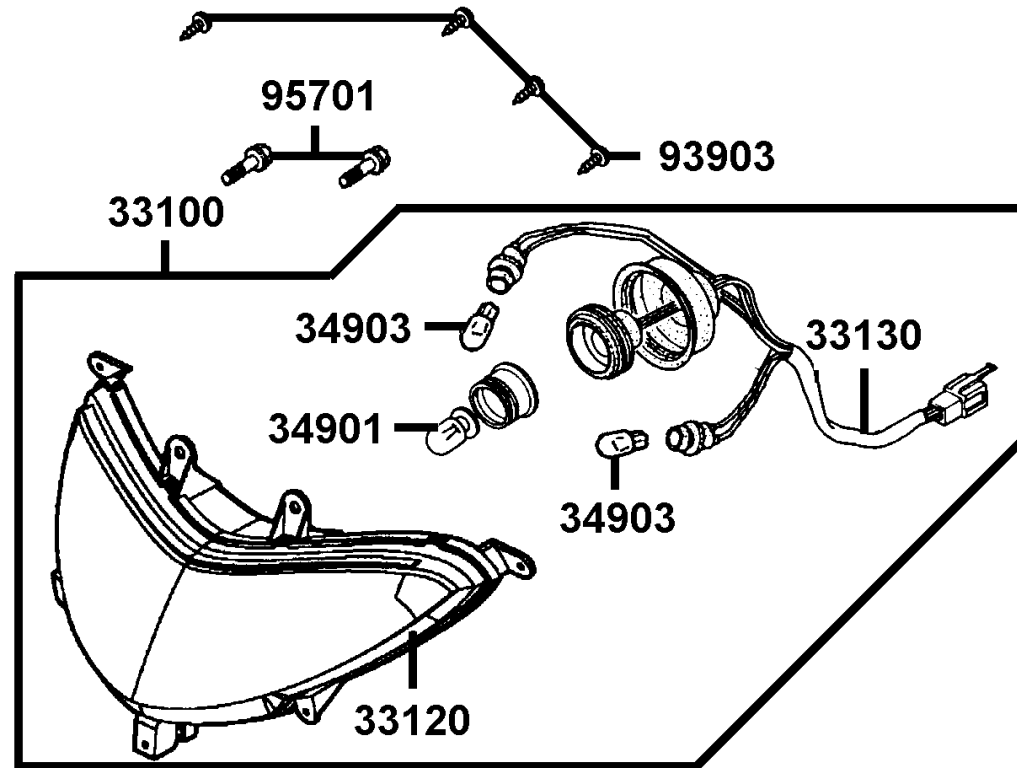

F 1

販賣記號 Sales mark	項目 Ref no	零件號碼 Part no	版數 Ver	英 文 名 稱 Description	中 文 名 稱 Chinese	需要用量 Regd no	參考價 Ref Price
		33100-KKC4-E000	3	LIGHT ASSY HEAD	前燈組	1	
		33120-KKC4-E000	1	UNIT HEAD LIGHT	前燈殼	1	
		33130-KKC4-E000	0	SOCKET COMP	前燈配線	1	
		34901-KED9-900	0	BULB HEAD LIGHT	前燈泡	1	
		34903-KCP-9000	0	BULB POSITION LIGHT	位置燈燈泡	2	
		93903-35380	0	SCREW TAPPING 5*16	螺釘 5*16	4	
		95701-06012-08	0	BOLT FLANGE 6*12	螺絲 6*12	2	

F 2 Speedometer

儀
錶

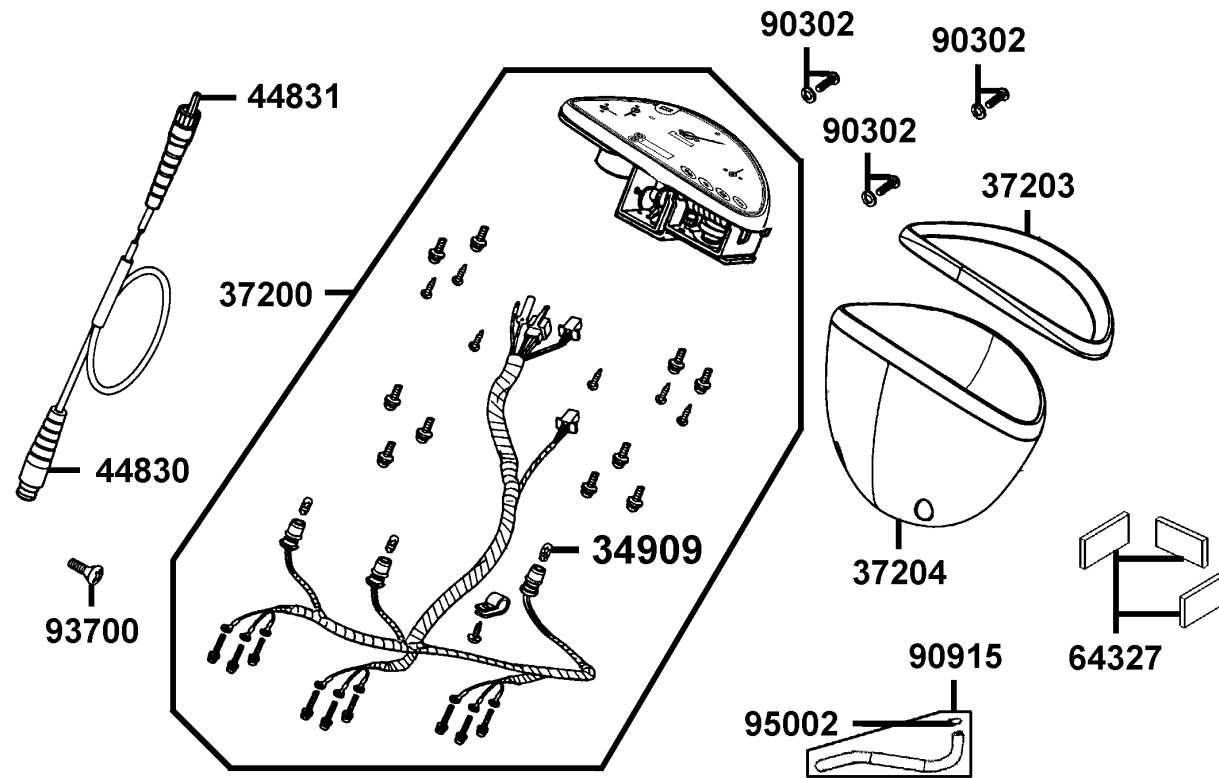

販賣記號 Sales mark	項目 Ref no	零件號碼 Part no	版數 Ver	英 文 名 稱 Description	中 文 名 稱 Chinese	需要用量 Regd no	參考價 Ref Price
		34909-KBE-9000	0	BULB WEDGE BASE T6.5	儀錶內指示燈泡	3	
		37200-KKC4-900	3	METER ASSY SPEED (LCD)	儀錶	1	
**		37203-KKC4-900	0	METER COVER FR	儀錶上蓋	1	
**		37204-KKC4-900	0	METER COVER RR	儀錶下蓋	1	
		44830-KKC4-9000	2	CABLE COMP SPDMT	速度錶導線	1	
		44831-KKC4-9000	0	CABLE INNER	速度錶內導線	1	
		64327-KKC4-900	0	SPONGE TAPE METER COVER	儀錶用海綿雙面膠	3	
		90302-GY6-9400	0	BOLT -WASH 5*16	螺絲 5*16	3	
		90915-KKC4-9000	0	TUBE DRAIN	洩流管	1	
		93700-05018-0H	0	SCREW OVAL 5*18	螺絲 5*18	1	
		95002-50000	0	CLIP C9 TUBE	管夾	1	

F 3 Handle Steering ● Handle Cover

轉
向
手
柄
●
手
柄
蓋

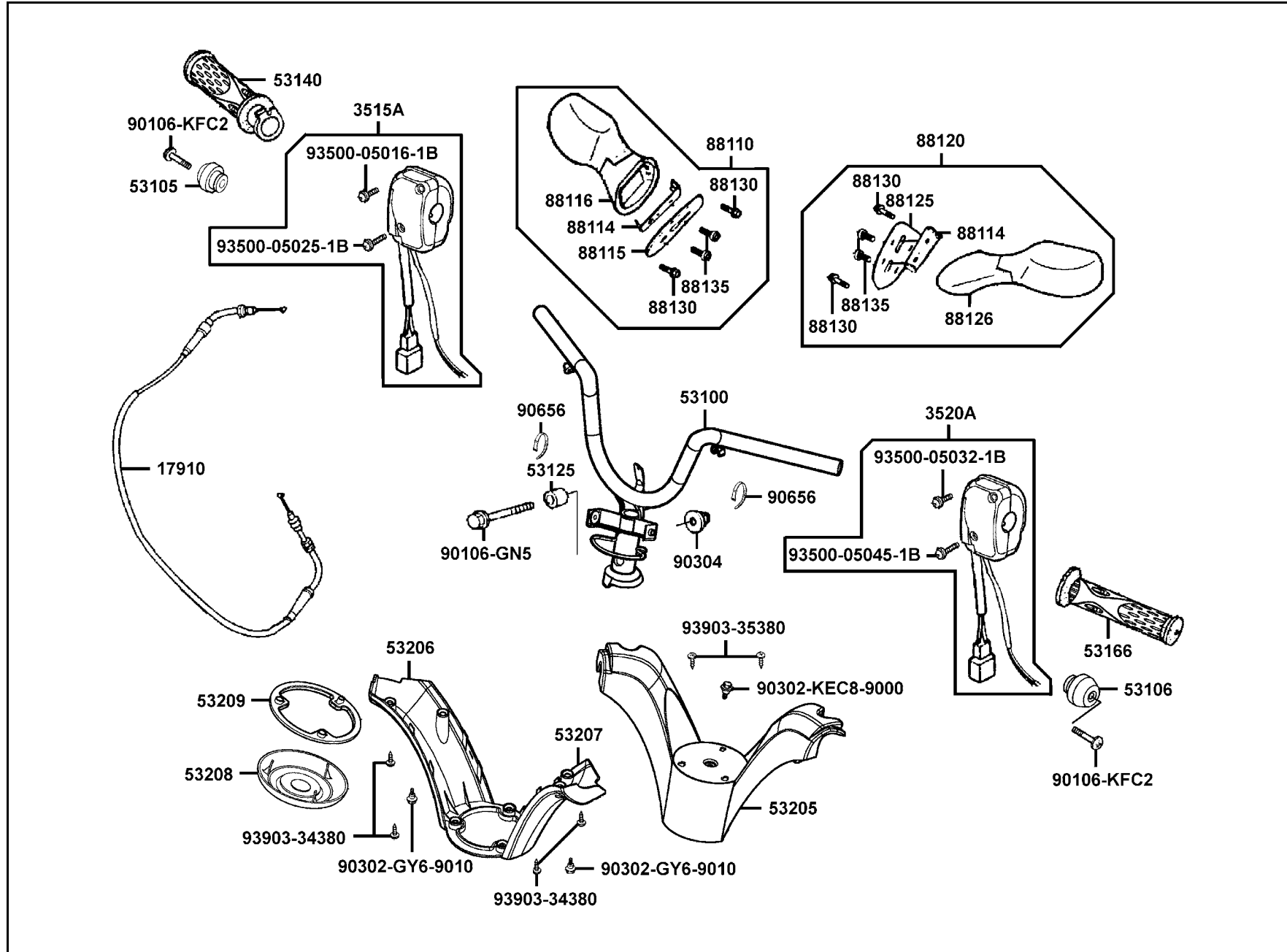

販賣記號 Sales mark	項目 Ref no	零件號碼 Part no	版數 Ver	英文名稱 Description	中文名稱 Chinese	需要用量 Regd no	參考價 Ref Price
		17910-KKC4-9000	0	CABLE COMP THROT	節流導線	1	
		17911-KKC4-9000	0	CABLE B COMP THROT	節流導線 B	1	
		3515A-KKC4-9000	1	SW ASSY RH HNDL COMP	右邊開關組	1	
		3520A-KBE-9000	2	SW ASSY L HNDL COMP	左邊開關組	1	
		53100-KKC4-9000	0	HANDLE COMP STRG	轉向手柄	1	
		53105-KFC8-9000	2	END R STRG HANDLE	手柄右平衡端子	1	
		53106-KFC8-9000	0	END L STRG HANDLE	手柄左平衡端子	1	
		53125-GN5-9010	0	COLLAR HANDLE SET	套筒	1	
**		53140-KKC4-900	0	GRIP COMP THROT	節流管套組	1	
**		53166-KGB5-900	0	GRIP L HANDLE	手柄左橡皮套	1	
**		53205-KKC4-900	0	COVER HNDL UP	手柄上蓋	1	
**		53206-KKC4-900	0	COVER R HANDLE LOW	手柄下蓋右側蓋	1	
**		53207-KKC4-900	0	COVER L HANDLE LOW	手柄下蓋左側蓋	1	
**		53208-KKC4-900	0	GRILL HANDLE UP	手柄底蓋	1	
		53209-KKC4-9000	0	PACKING HANDLE UP	手柄底蓋襯墊	1	
**		88110-KKC4-900	7	MIRROR ASSY R BACK	右後視鏡	1	
		88114-KKC4-9000	3	STAY MIRROR	後視鏡鐵座	2	
		88115-KKC4-9000	0	PAD R MIRROR	右後視鏡襯墊	1	
		88116-KKC4-9000	3	BASE R MIRROR	右後視鏡底座	1	
**		88120-KKC4-900	7	MIRROR ASSY L BACK	左後視鏡	1	

F 3 Handle Steering ● Handle Cover

轉向手柄 ● 手柄蓋

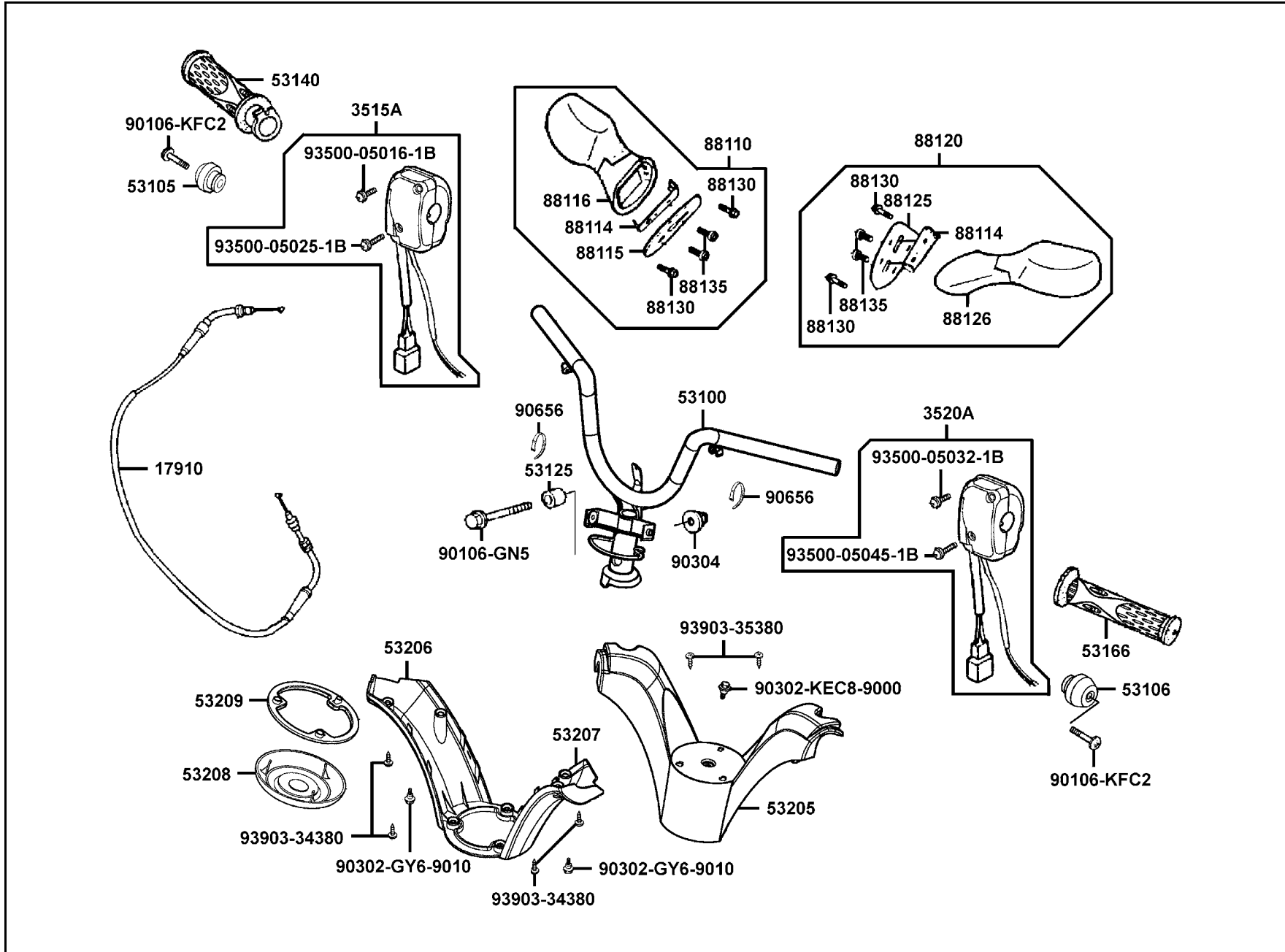

販賣記號 Sales mark	項目 Ref no	零件號碼 Part no	版數 Ver	英 文 名 稱 Description	中 文 名 稱 Chinese	需要用量 Regd no	參考價 Ref Price
		88125-KKC4-9000	0	PAD L MIRROR	左後視鏡襯墊	1	
		88126-KKC4-9000	3	BASE L MIRROR	左後視鏡底座	1	
		88130-KKC4-9000	0	BOLT SPECIAL	特殊螺絲	4	
		88135-KKC4-9000	1	SCREW PAN 5*20	螺絲 5*20	4	
		90106-GN5-9010	0	BOLT FLANGE 10*50	特殊螺絲 10X50	1	
		90106-KFC2-9000	0	BOLT WASH 8MM	螺絲 8MM	2	
		90302-GY6-9010	0	BOLT WASH 5*12	螺絲 5X12	2	
		90302-KEC8-9000	0	BOLT PAN 5*9	螺釘 5*9	1	
		90304-GE8-0040	0	NUT U 10MM	螺帽 10MM	1	
		90656-GY6-9110	0	BAND OIL HOSE	油管束帶	2	
		93500-05016-1B	0	SCREW PAN 5*16	螺絲 5*16	1	
		93500-05025-1B	0	SCREW PAN 5*25	螺絲 5*25	1	
		93500-05032-1B	0	SCREW PAN 5*32	螺絲 5*32	1	
		93500-05045-1B	0	SCREW PAN 5*45	螺絲 5*45	1	
		93903-34380	0	SCREW TAPPING 4*12	螺釘 4X12	4	
		93903-35380	0	SCREW TAPPING 5*16	螺釘 5*16	2	

F 4 Brake Master Cylinder

煞車主油缸

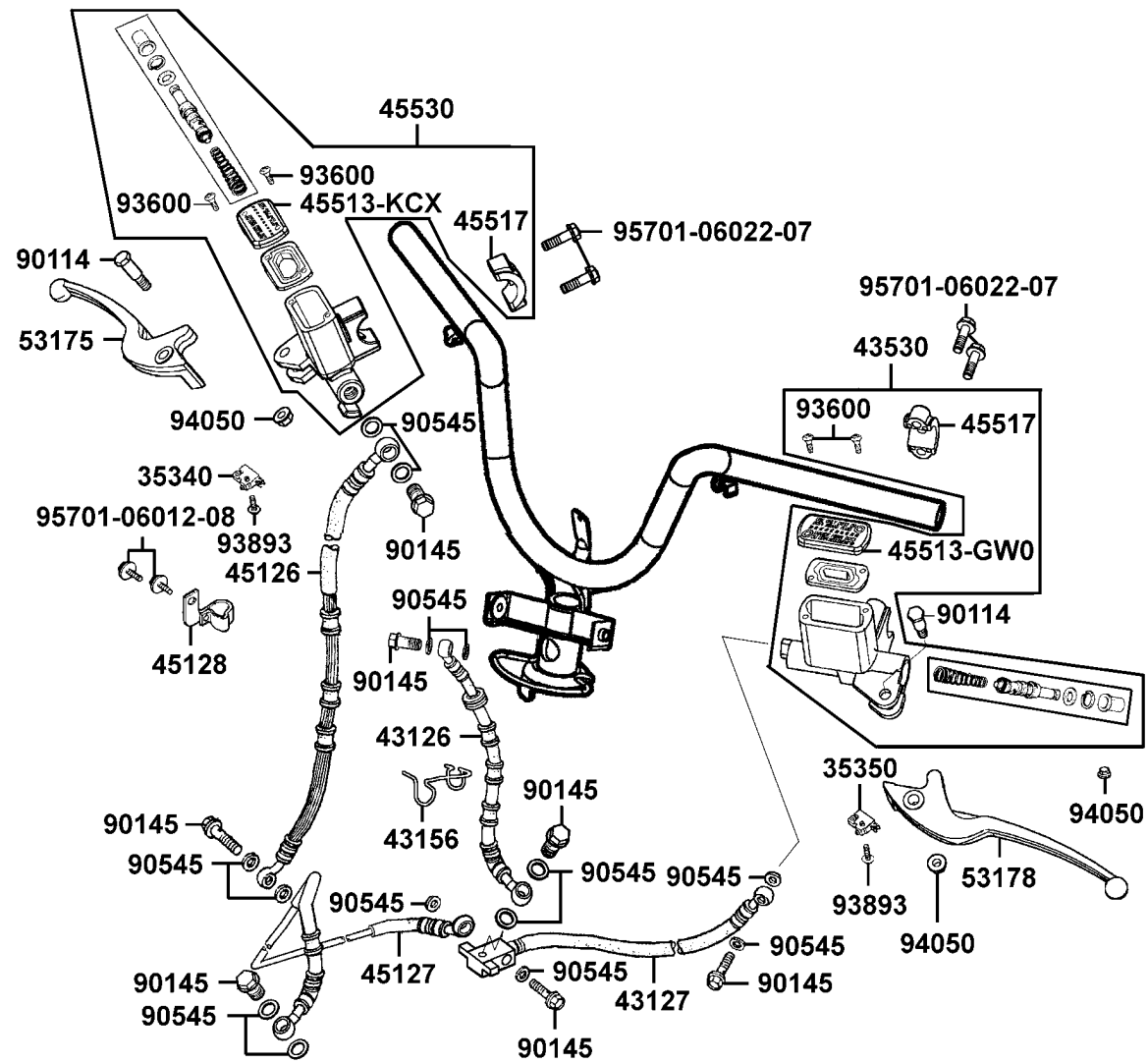

販賣記號 Sales mark	項目 Ref no	零件號碼 Part no	版數 Ver	英文名稱 Description	中文名稱 Chinese	需要用量 Regd no	參考價 Ref Price
		35340-KBN-9000	0	SW ASSY FR STOP	煞車燈前置開關	1	
		35350-KBN-9000	0	SW ASSY RR STOP	煞車燈後置開關	1	
		43126-KKC4-9000	3	HOSE ASSY C/P RR BRAKE	後煞車管組後段	1	
		43127-KKC4-9000	0	HOSE ASSY M/C RR BRAKE	後煞車油管前段	1	
		43156-KKC4-9000	1	CLAMPER HOSE RR	後煞車管夾	2	
		43530-KKC4-3050	0	CYLINDER SET RR MASTER	後煞車主油缸	1	
		45126-KKC4-9000	0	HOSE ASSY FR BRAKE	前煞車油管	1	
		45127-KKC4-9000	0	HOSE ASSY C/P FR BRAKE	前煞車運動輔助油管	1	
		45128-KKC4-9000	0	CLAMPER FR BRAKE HOSE	前煞車管夾	1	
		45513-GW0-9120-M1	0	CAP MASTER CYLINDER	煞車主油缸蓋	1	
		45513-KCX-M000-US	1	CAP MASTER CYLINDER	煞車主油缸蓋	1	
		45517-KAF-9100	0	HOLDER M/C	主油缸固定座	2	
		45530-KFC8-E000-IT	2	CYLINDER SET FR MASTER	前煞車主油缸	1	
**		53175-KFA5-E10	0	LEVER R STRG HANDLE	手柄右拉桿	1	
**		53178-KFC8-E10	0	LEVER L STRG HANDLE	手柄左拉桿	1	
		90114-166-0070	1	BOLT HANDLE LEVER	右拉桿固定螺栓	2	
		90145-MS9-6120-M1	0	OIL BOLT 10*22	油管螺絲 10*22	7	
		90545-300-0010	2	WASHER OIL BOLT	華司	14	
		93600-04012-1G	0	SCREW FLAT 4*12	螺絲 4*12	4	
		93893-04012-18	0	SCREW WASHER 4*12	螺絲 4*12	2	

F 4 Brake Master Cylinder

煞車主油缸

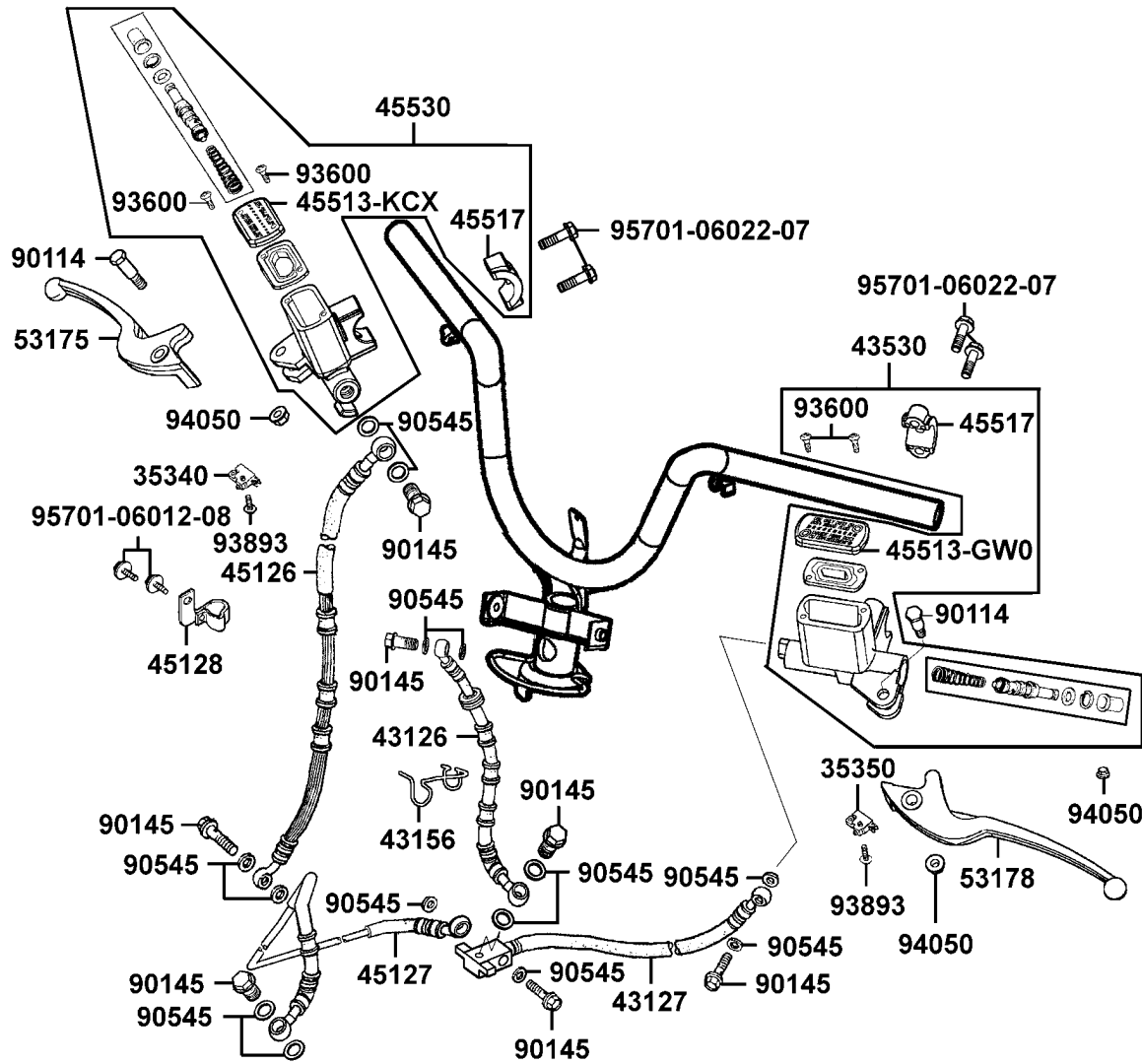

販賣記號 Sales mark	項目 Ref no	零件號碼 Part no	版數 Ver	英 文 名 稱 Description	中 文 名 稱 Chinese	需要用量 Regd no	參考價 Ref Price
		94050-06080	0	NUT FLANGE 6MM	螺帽 6MM	3	
		95701-06012-08	0	BOLT FLANGE 6*12	螺絲 6*12	2	
		95701-06022-07	0	BOLT FLANGE 6*22	螺絲 6*22	4	

F 5 Front Cover●Floor Panel

前護蓋 ● 腳踏板

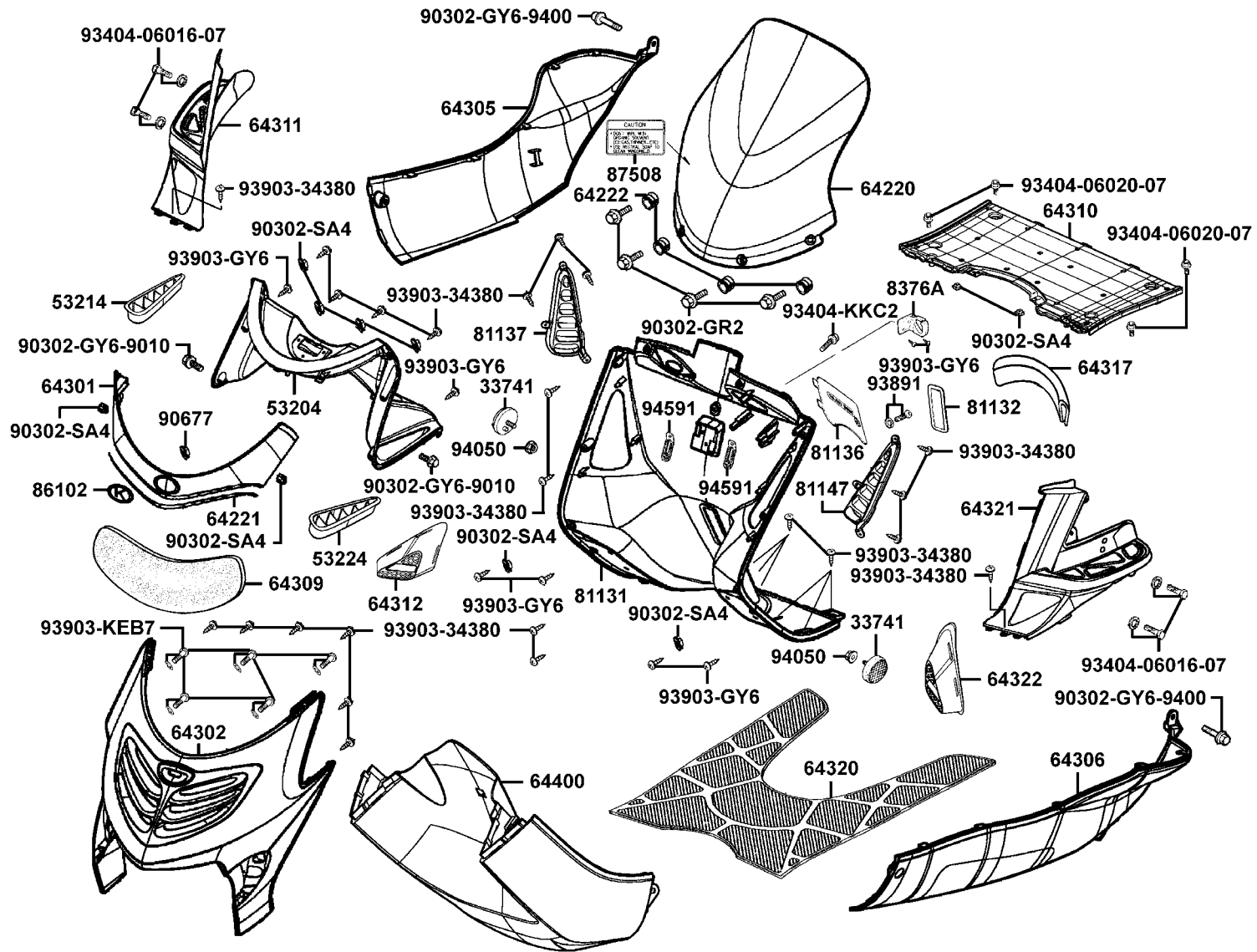

販賣記號 Sales mark	項目 Ref no	零件號碼 Part no	版數 Ver	英文名稱 Description	中文名稱 Chinese	需要用量 Regd no	參考價 Ref Price
		33741-GY6-C300	1	REFLEX REFLECTOR	反光鏡片	2	
**		53204-KKC4-900	2	COVER METER	儀錶外蓋	1	
**		53214-KKC4-900	0	GRID R METER COVER	儀錶外蓋右格板	1	
**		53224-KKC4-900	0	GRID L METER COVER	儀錶外蓋左格板	1	
		64220-KKC4-9000	0	WIND SCREEN	遮陽板	1	
		64221-KKC4-9000	0	SEAL WIND SCREEN	橡皮	1	
		64222-KKC4-9000	3	RUBBER WIND SCREEN	遮陽板橡皮	4	
**		64301-KKC4-900	0	COVER SCREEN	前燈上蓋	1	
**		64302-KKC4-900	0	MOLDING FR	前護板	1	
**		64305-KKC4-900	1	SKIRT R SIDE	右邊軌	1	
**		64306-KKC4-900	2	SKIRT L SIDE	左邊軌	1	
		64309-KKC4-9000	0	GRILL FR COVER	前蓋格板	1	
**		64310-KKC4-900	0	FLOOR PANEL	腳踏板	1	
**		64311-KKC4-900	3	COVER R PILLION STEP	後座右踏板蓋	1	
**		64312-KKC4-900	3	GRID R PILLION STEP	後座右踏板蓋格板	1	
		64317-KKC4-9000	0	SEAL METER COVER	碼錶蓋防水封	1	
**		64320-KKC4-900	0	MAT FLOOR	踏板墊	1	
**		64321-KKC4-900	2	COVER L PILLION STEP	後座左踏板蓋	1	
**		64322-KKC4-900	1	GRID L PILLION STEP	後座左踏板蓋格板	1	
**		64400-KKC4-900	0	COWL UNDER	下罩	1	

F 5 Front Cover●Floor Panel

前護蓋 ● 腳踏板

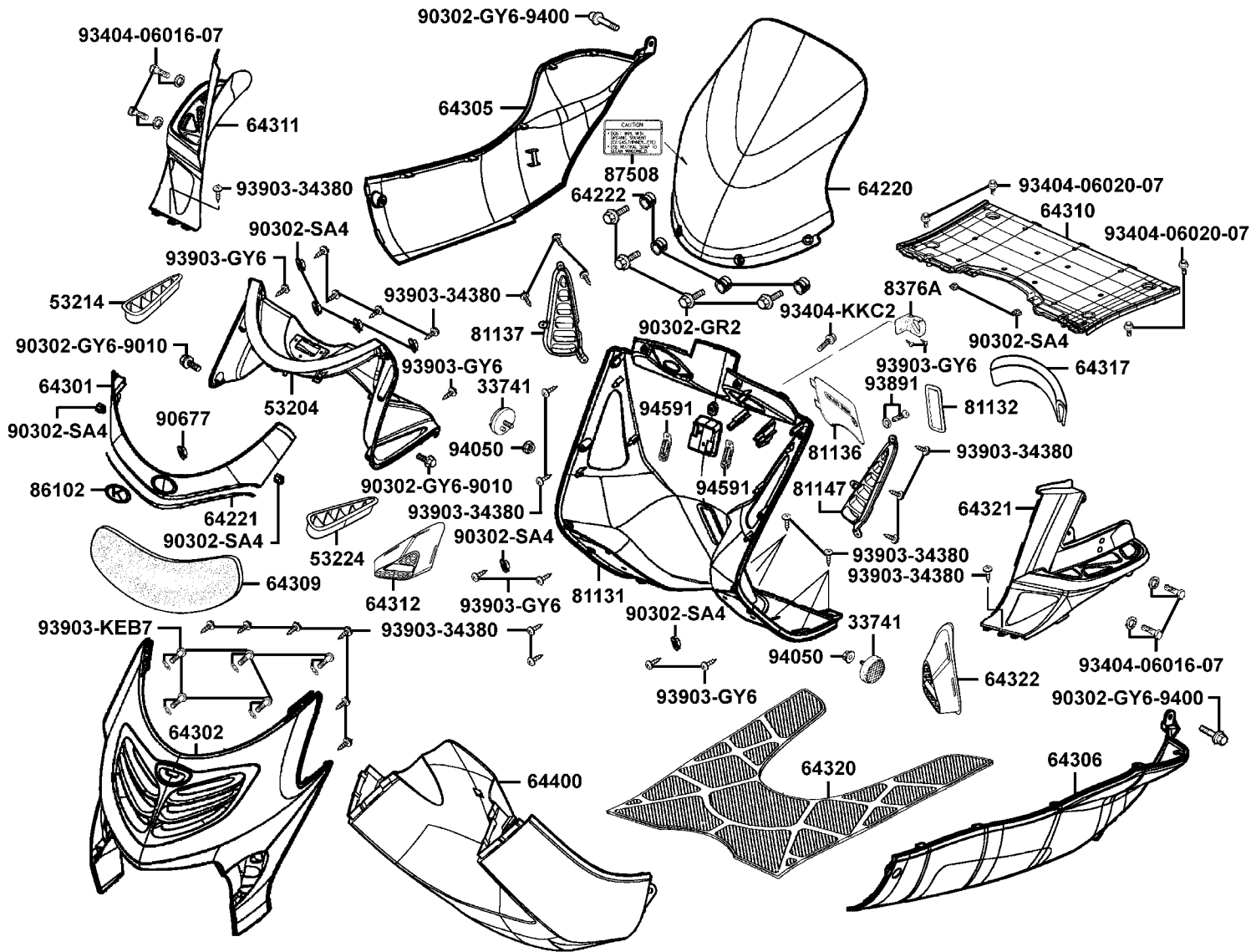

販賣記號 Sales mark	項目 Ref no	零件號碼 Part no	版數 Ver	英 文 名 稱 Description	中 文 名 稱 Chinese	需要用量 Regd no	參考價 Ref Price
**		81131-KKC4-900	0	LEG SHIELD	行旅內箱	1	
**		81132-KEB7-900	0	LID LEG SHIELD	內箱蓋	1	
**		81136-KKC4-900	0	LID RESERVE TANK	預備水箱覆蓋	1	
**		81137-KKC4-900	0	GRID R LEG SHIELD	內箱右通風格板	1	
**		81147-KKC4-900	0	GRID L LEG SHIELD	內箱左通風格板	1	
		8376A-KBE-900	3	CLIP ASSY CENTER	中心掛鉤	1	
		86102-KKC4-900	1	EMB K-LOGO 28.5MM	標誌	1	
		87508-KKC4-E00	0	LABEL CLEANNESS CAUTION	貼紙	1	
		90302-GR2-0000	1	BOLT WASH 5*16	螺絲 5*16	4	
		90302-GY6-9010	0	BOLT WASH 5*12	螺絲 5*12	2	
		90302-GY6-9400	0	BOLT WASH 5*16	螺絲 5*16	2	
		90302-SA4-0040	1	NUT SPRING 4MM	螺帽 4MM	10	
		90677-GR1-0030	1	NUT CLIP 5MM	彈簧螺帽 5MM	1	
		93404-06016-07	0	BOLT WASHER 6*16	螺絲 6*16	4	
		93404-06020-07	0	BOLT WASHER 6*20	螺絲 6*20	4	
		93404-KKC2-900	0	BOLT WASHER 6*16	螺絲 6*16	1	
		93891-05012-07	0	SCREW WASHER 5*12	螺絲 5*12	1	
		93903-34380	0	SCREW TAPPING 4*12	螺釘 4*12	28	
		93903-GY6-9000	0	SCREW TAPPING 4*14	螺釘 4*14	8	
		93903-KEB7-9000	0	SCREW WASHER 4MM	螺絲華司 4MM	5	

F 5 Front Cover●Floor Panel

前護蓋 ● 腳踏板

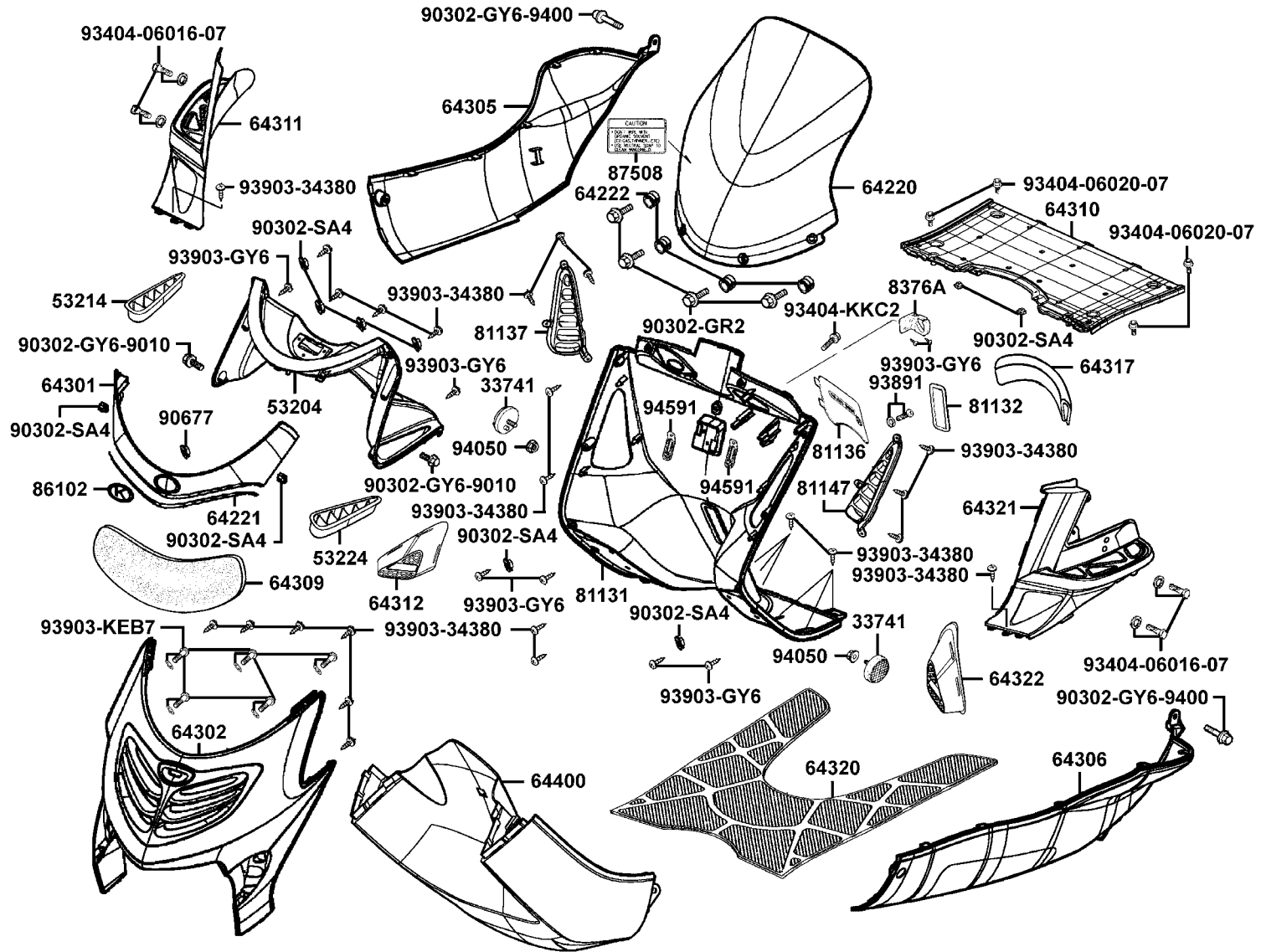

F 5

販賣記號 Sales mark	項目 Ref no	零件號碼 Part no	版數 Ver	英 文 名 稱 Description	中 文 名 稱 Chinese	需要用量 Regd no	參考價 Ref Price
		94050-06080	0	NUT FLANGE 6MM	螺帽 6MM	2	
		94591-27000	0	CLIP 2*70	夾子 2*70	2	

F 6 Front Cushion

前
避
震
器

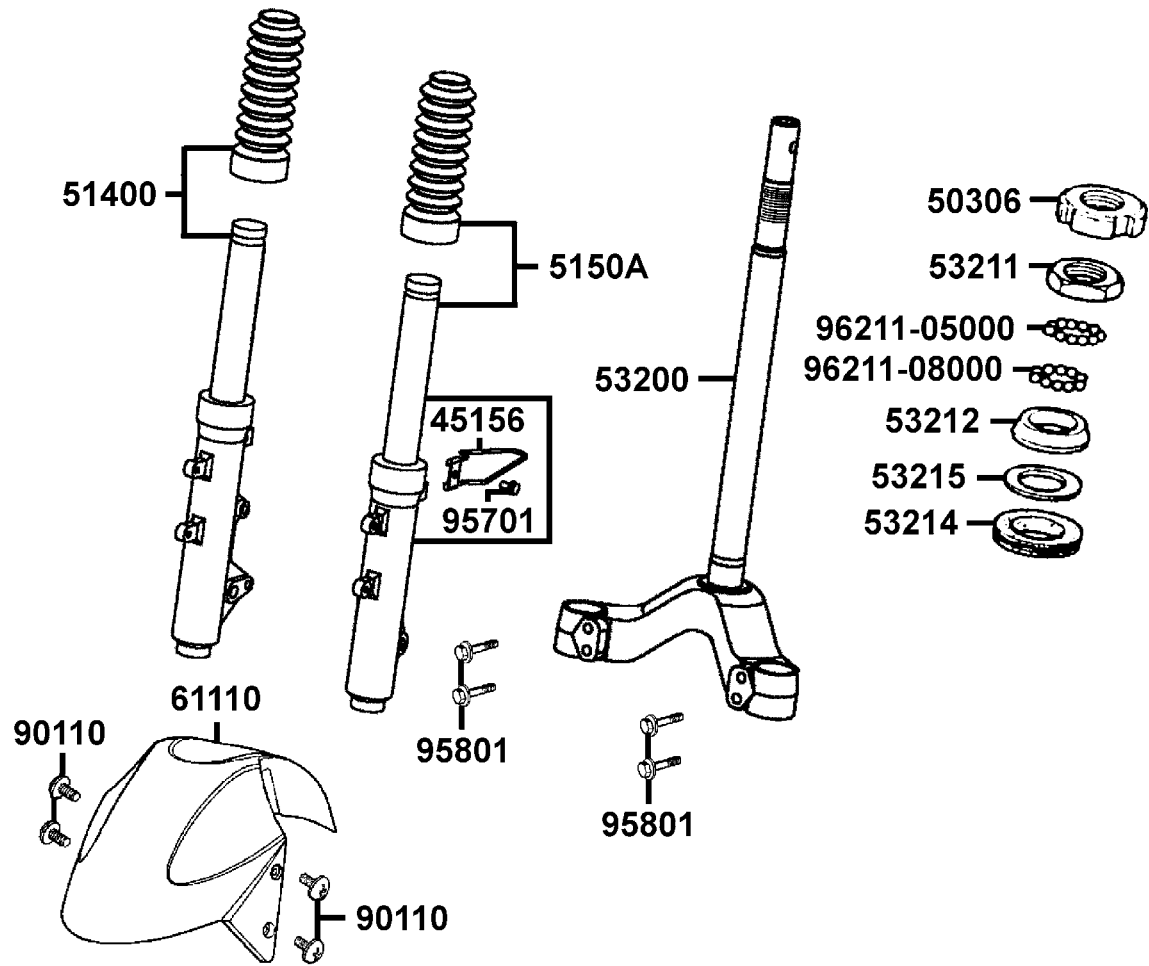

F 6

販賣記號 Sales mark	項目 Ref no	零件號碼 Part no	版數 Ver	英 文 名 稱 Description	中 文 名 稱 Chinese	需要用量 Regd no	參考價 Ref Price
		45156-KCE-9000	1	CLAMPER FR BRK CABLE	導線夾	1	
		50306-196-0010	0	NUT STRG STEM LOCK	主幹螺帽	1	
**		51400-KKC4-900	2	FORK ASSY R FR	右前避震器組	1	
**		5150A-KKC4-900	3	FORK SET L FR	左前避震器組	1	
		53200-KKC2-9000	1	STEM COMP STRG	轉向主桿	1	
		53211-GY6-9400	0	RACE STRG TOP CONE	上錐體座圈	1	
		53212-250-0110	0	RACE (STRG BOTTOM) CONE	下錐體座圈	1	
		53214-250-0010	0	DUST SEAL STRG (HEAD)	防塵油封	1	
		53215-250-0010	0	WASHER STRG HDL DUST-SEAL	華司	1	
**		61110-KHD8-900	2	FENDER FR	前土除	1	
		90110-KEB7-9000	0	SCREW SPECIAL 6*14	特殊螺絲 6*14	4	
		95701-06012-08	0	BOLT FLANGE 6*12	螺絲 6*12	1	
		95801-08040-08	0	BOLT FLANGE 8*40	螺絲 8*40	4	
		96211-05000	0	BALL STEEL #5	鋼珠 #5	26	
		96211-08000	0	BALL STEEL #8	鋼珠 #8	19	

F 7 Front Wheel

前輪

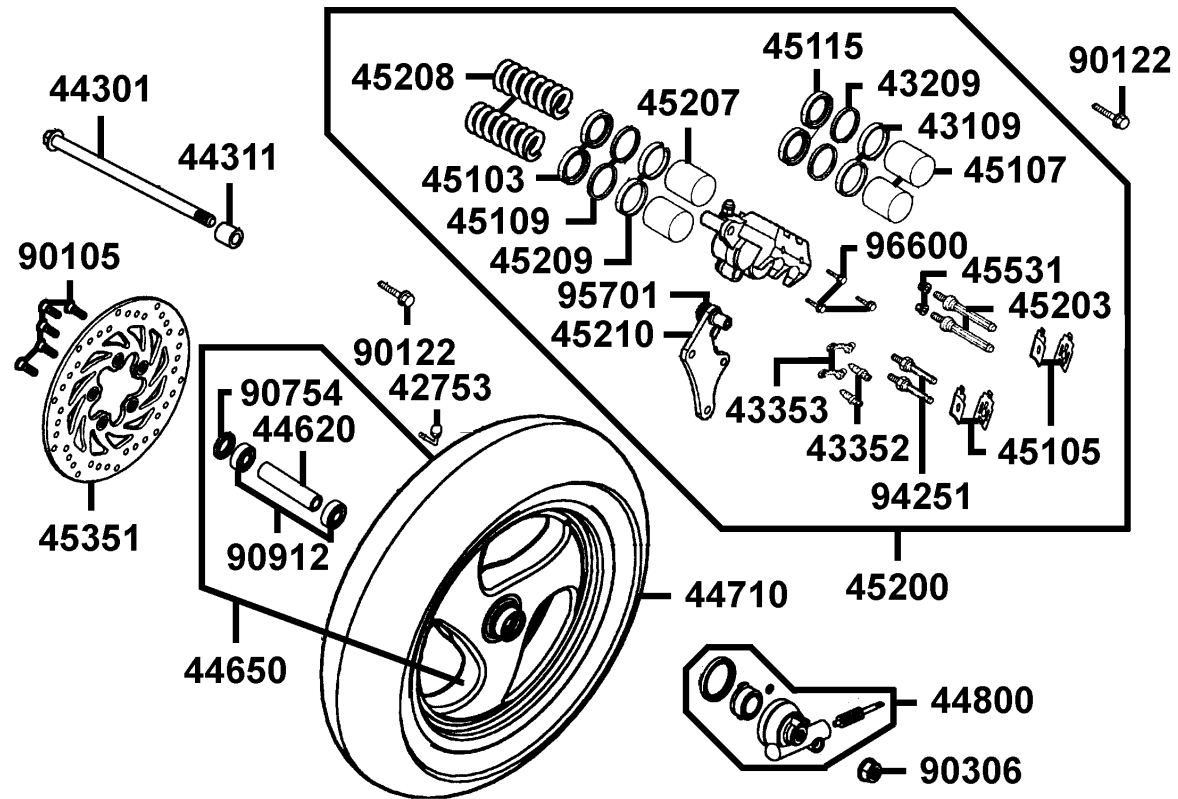

販賣記號 Sales mark	項目 Ref no	零件號碼 Part no	版數 Ver	英文名稱 Description	中文名稱 Chinese	需要用量 Regd no	參考價 Ref Price
		42753-KCX-9000	1	VALVE (PVR-70B)	打氣嘴	1	
		43109-MA3-0070	0	DUST SEAL	防塵油封	2	
		43209-MA3-0070	0	SEAL PISTON	活塞油封	2	
		43352-568-0030	3	SCREW BLEEDER	加油嘴	2	
		43353-461-7710-M1	0	CAP BLEEDER	加油嘴蓋	2	
		44301-KCX-900	1	AXLE FR WHEEL	前輪軸	1	
		44311-KBE-9000	0	COLLAR FR WHEEL SIDE	前輪邊套筒	1	
		44620-KHD8-9000	0	COLLAR FR AXLE DISTANCE	前輪軸距套筒	1	
**		44650-KHD8-30A	3	WHEEL SET FR	前輪圈組	1	
		44710-KKC4-900	2	TIRE ASSY FR	前輪胎	1	
		44800-KFA5-9000	1	GEAR BOX ASSY	速度齒輪箱組	1	
		45103-MR7-0070	0	SEAL JOINT	油封	2	
		45105-KKC4-305	0	PAD ASSY	煞車摩擦板組	2	
		45107-KKC4-9000	0	PISTON	卡鉗活塞	2	
		45109-KFA6-9000	0	DUST SEAL	防塵封	2	
		45115-KKC4-9000	0	COVER DUST	防塵蓋	2	
**		45200-KKC4-900	1	CALIPER ASSY FR	前煞車卡鉗	1	
		45203-KKC4-9000	0	PIN HANGER	吊架銷	2	
		45207-KKC4-9000	0	PISTON	卡鉗活塞	2	
		45208-KKC4-9000	0	SPRING PAD	摩擦板彈簧	2	

F 7 Front Wheel

前輪

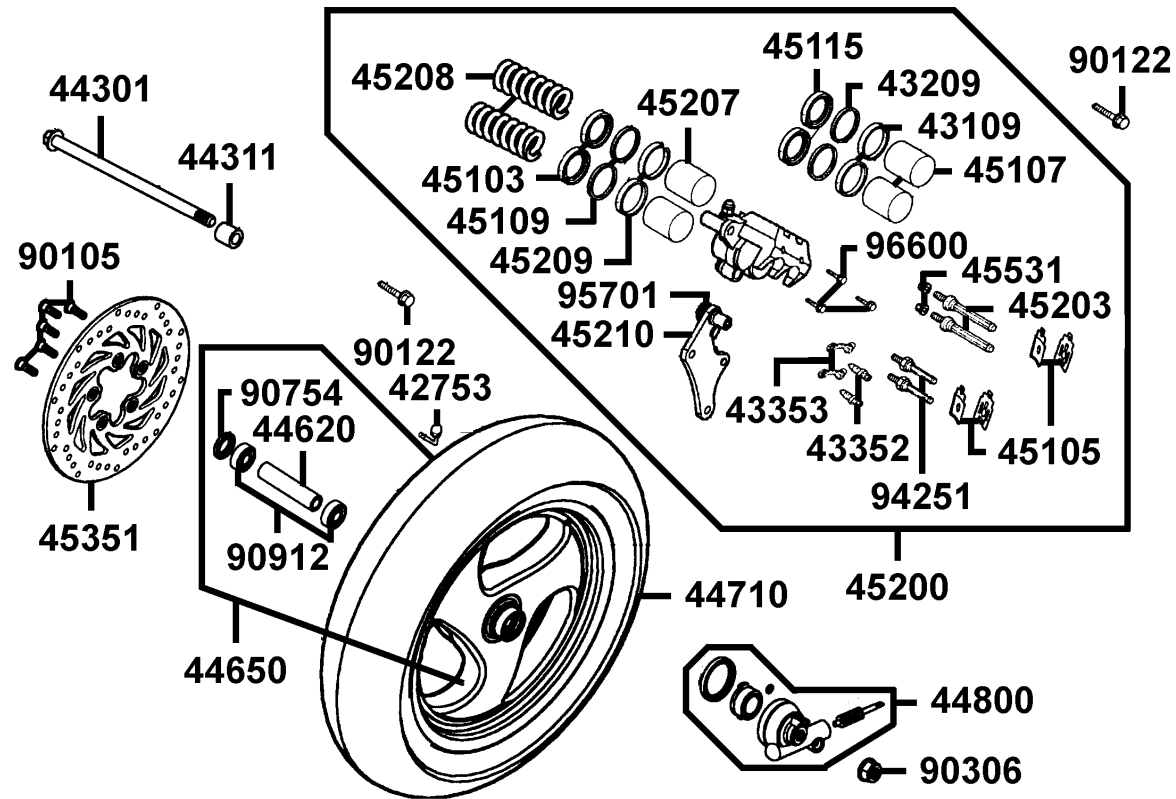

販賣記號 Sales mark	項目 Ref no	零件號碼 Part no	版數 Ver	英文名稱 Description	中文名稱 Chinese	需要用量 Regd no	參考價 Ref Price
		45209-KFA6-9000	0	SEAL PISTON	活塞油封	2	
		45210-KKC4-9000	0	BRACKET FR	前煞車卡鉗托架	1	
		45351-KHE7-E000	0	DISK FR BRAKE	前煞車圓盤	1	
		45531-GR1-9510	0	PLUG	塞蓋	2	
		90105-KR3-0010	1	BOLT FR DISK 8*24	螺絲 8*24	5	
		90122-KBE-9000	0	BOLT FLANGE 8*32	螺絲 8*32	2	
		90306-KF0-901	0	NUT U FLANGE 12MM	螺帽 12MM	1	
		90754-GC8-0000	0	DUST SEAL 20*32*5	前輪防塵封 20*32*5	1	
		90912-KLF-00B	0	BEARING 6201 LLU	前輪軸承 6201	2	
		94251-08400	0	PIN LOCK 8MM	固定銷 8MM	2	
		95701-08020-08	0	BOLT FLANGE 8*20	螺絲 8*20	2	
		96600-KKC4-9000	0	SOCKET BOLT	螺絲	3	

F 8 Rear Wheel

後輪

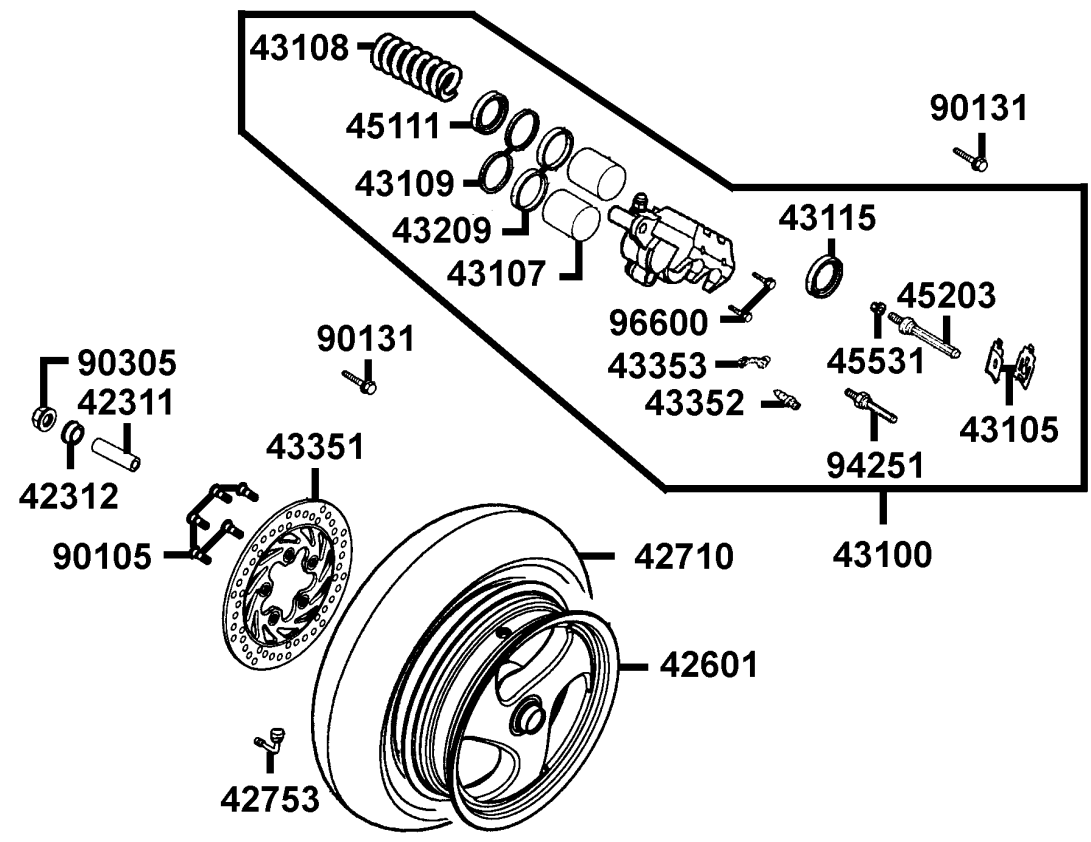

販賣記號 Sales mark	項目 Ref no	零件號碼 Part no	版數 Ver	英文名稱 Description	中文名稱 Chinese	需要用量 Regd no	參考價 Ref Price
		42311-KHE7-E000	0	COLLAR RR AXLE A	後輪軸套筒 A	1	
		42312-KHE7-E000	0	COLLAR RR AXLE SIDE	後輪軸邊套筒	1	
**		42601-KHE7-E00	1	WHEEL RR CAST	後輪圈	1	
		42710-KKC4-900	1	TIRE ASSY RR	後輪胎	1	
		42753-KBN-9020-M2	0	VALVE (TR 412)	打氣嘴	1	
**		43100-KKC4-900	0	CALIPER ASSY RR	後煞車卡鉗組	1	
		43105-KKC4-9000	0	PAD COMP	煞車摩擦板	2	
		43107-KKC4-9000	0	PISTON	卡鉗活塞	2	
		43108-KKC4-9000	0	SPRING PAD	摩擦板彈簧	1	
		43109-KKC4-9000	0	DUST SEAL	防塵封	2	
		43115-KKC4-9000	0	COVER DUST	防塵蓋	1	
		43209-KKC4-9000	0	SEAL PISTON	活塞油封	2	
		43351-KHE7-E00	1	DISK RR BRAKE	後煞車圓盤	1	
		43352-568-0030	3	SCREW BLEEDER	加油嘴	1	
		43353-461-7710-M1	0	CAP BLEEDER	加油嘴蓋	1	
		45111-KKC4-9000	0	SEAL	油封	1	
		45203-KKC4-9000	0	PIN HANGER	吊架銷	1	
		45531-GR1-9510	0	PLUG	塞蓋	1	
		90105-KR3-0010	1	BOLT FR DISK 8*24	螺絲 8*24	5	
		90131-GW0-9110	0	BOLT FLANGE 8*35	螺絲 8*35	2	

F 8 Rear Wheel

後輪

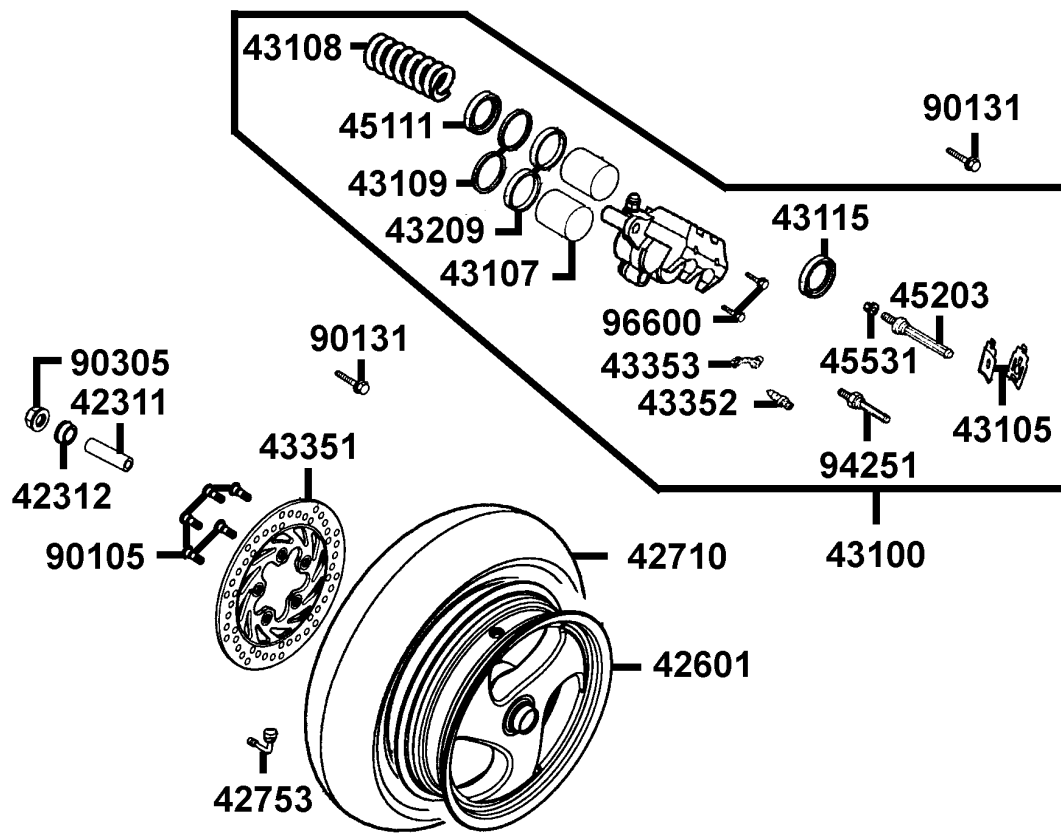

F 8

販賣記號 Sales mark	項目 Ref no	零件號碼 Part no	版數 Ver	英 文 名 稱 Description	中 文 名 稱 Chinese	需要用量 Regd no	參考價 Ref Price
		90305-KW6-9120-M2	0	NUT U FLANGE 16MM	螺帽 16MM	1	
		94251-08400	0	PIN LOCK 8MM	固定銷 8MM	1	
		96600-KKC4-9000	0	SOCKET BOLT	螺絲	2	

F 9 Seat

座墊

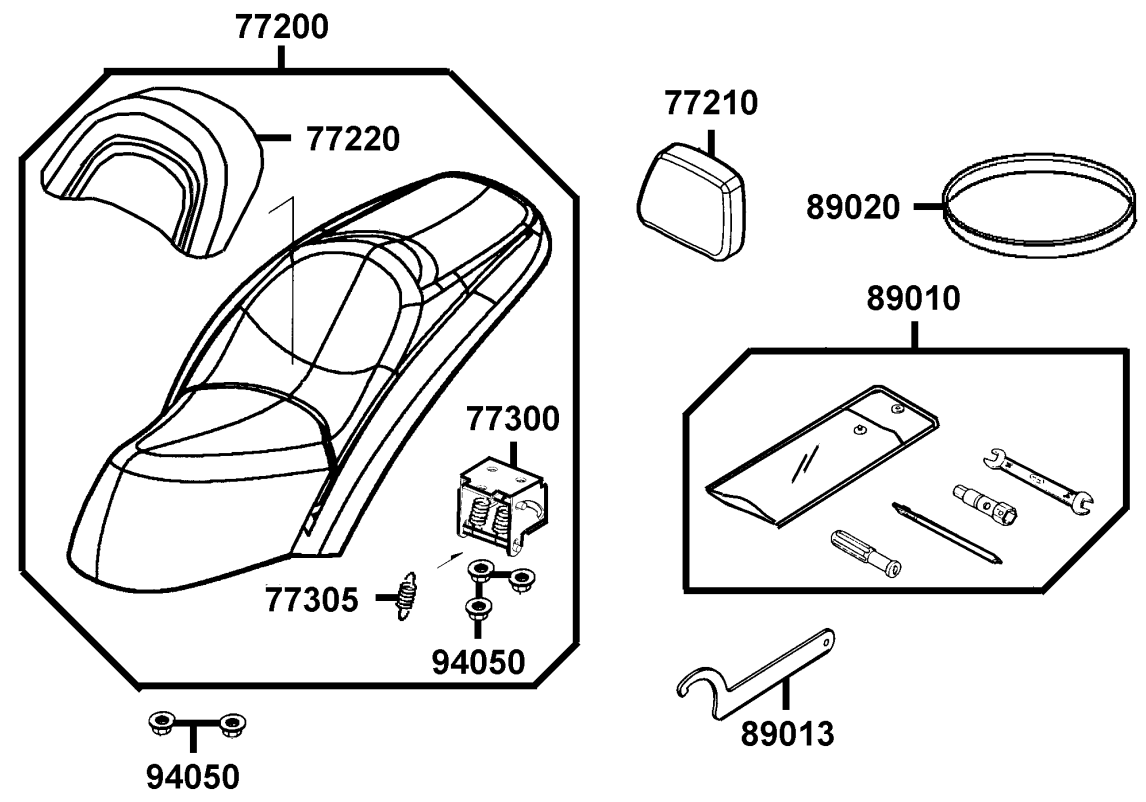

F9

販賣記號 Sales mark	項目 Ref no	零件號碼 Part no	版數 Ver	英文名稱 Description	中文名稱 Chinese	需要用量 Regd no	參考價 Ref Price
**		77200-KKC4-E10	0	SEAT ASSY	座墊	1	
**		77210-KKC4-900	0	SEAT ASSY BACK	後座墊靠	1	
**		77220-KKC4-910	0	SEAT ASSY PAD	前座墊靠	1	
		77300-KKC4-900	3	HINGE ASSY SEAT	座墊鉸鏈	1	
		77305-KKC4-9000	1	SPRING HINGE	座墊鉸鏈彈簧	2	
		89010-KKC4-900	0	TOOL SET	工具包組	1	
		89013-KFC8-E000	1	ADJUSTER REAR CUSHION	後避震器調整工具	1	
		89020-KKC4-900	0	BAND TOOL SET	束帶	1	
		94050-06080	0	NUT FLANGE 6MM	螺帽 6MM	5	

F 10 Fuel Tank

油箱

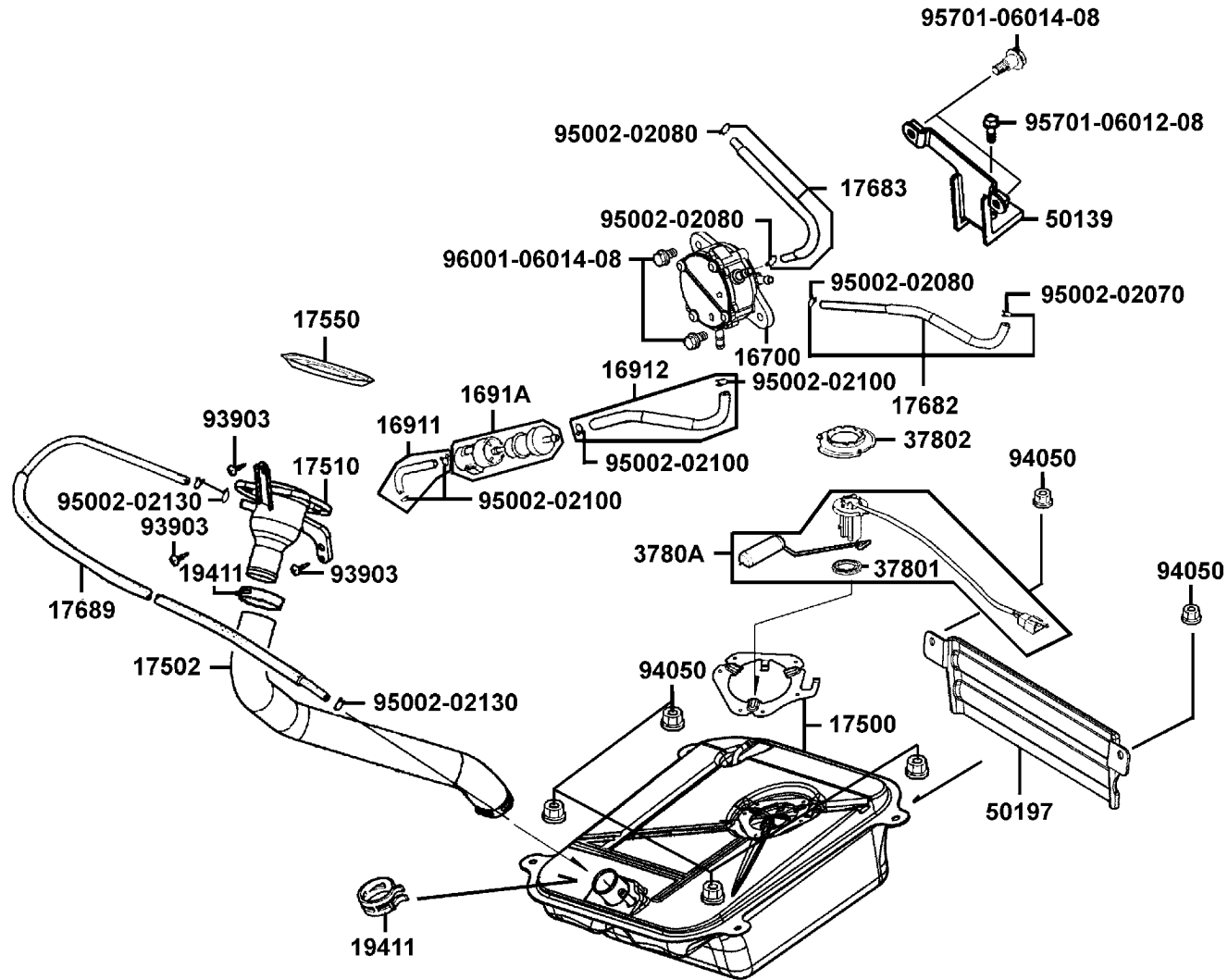

F10

販賣記號 Sales mark	項目 Ref no	零件號碼 Part no	版數 Ver	英文名稱 Description	中文名稱 Chinese	需要用量 Regd no	參考價 Ref Price
		16700-KHE7-900	5	FUEL PUMP ASSY	汽油泵浦	1	
		16911-KKC4-9000	0	TUBE ASSY TANK TO STRAINER	油管組	1	
		16912-KKC4-9000	0	TUBE ASSY STRAINER TO FUEL PUMP	油管組	1	
		1691A-KEC2-E000	0	STRAINER ASSY FUEL	汽油濾清器	1	
		17500-KKC4-9000	1	TANK COMP FUEL	油箱	1	
		17502-KKC4-9000	0	TUBE FUEL	油管	1	
		17510-KKC4-9000	0	PIPE ASSY FUEL FILLER	加油漏斗	1	
		17550-KHC4-9000	0	TRAY FUEL CAP	油箱護蓋	1	
		17682-KKC4-9000	0	TUBE ASSY VACUUM	真空管組	1	
		17683-KKC4-9000	0	TUBE ASSY FUEL	油管組	1	
		17689-KBE-9000	1	TUBE ASSY TANK-TO 3 WJT	油管	1	
		19411-KCB-9000	0	CLIP HOSE	管夾	2	
		37801-GA7-7000	1	PACKING BASE	墊圈盤	1	
		37802-GA7-7000	2	RET FUEL UNIT	浮筒計承件	1	
		3780A-KKC4-9000	1	FUEL UNIT ASSY	油量指示器組	1	
		50139-KKC4-9000	0	BRKT FUEL PUMP	汽油泵蓋支架	1	
		50197-KKC4-9000	0	STAY FLOOR	踏板支架	1	
		93903-35220	0	SCREW TAPPING 5*12	螺釘 5*12	3	
		94050-06080	0	NUT FLANGE 6MM	螺帽 6MM	6	
		95002-02070	0	CLIP B7 TUBE	管夾	1	

F 10 Fuel Tank

油
箱

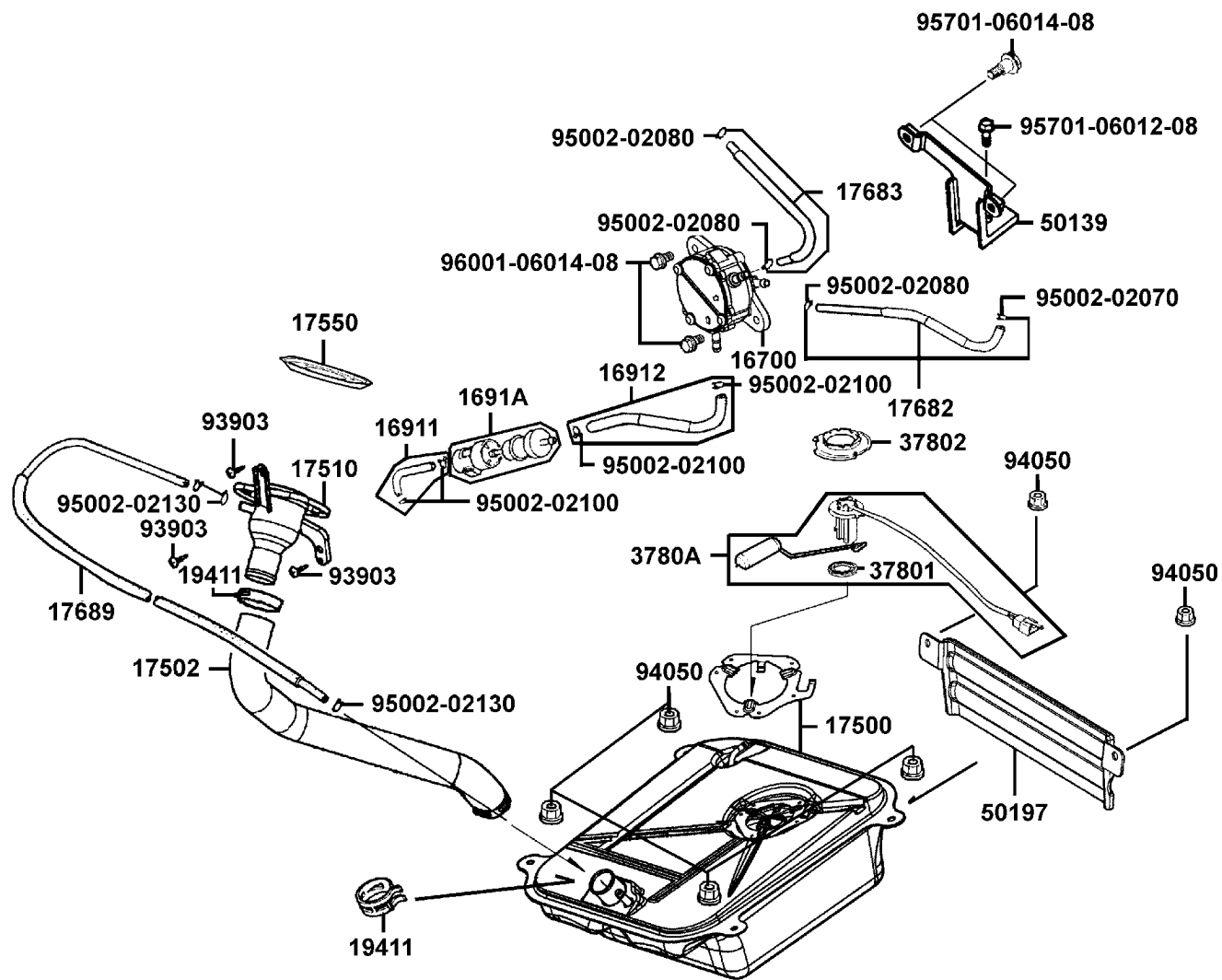

F10

販賣記號 Sales mark	項目 Ref no	零件號碼 Part no	版數 Ver	英文名稱 Description	中文名稱 Chinese	需要用量 Regd no	參考價 Ref Price
		95002-02080	0	CLIP B8 TUBE	管夾	3	
		95002-02100	0	CLIP B10 TUBE	管夾	4	
		95002-02130	0	CLIP B12.5 TUBE	管夾	3	
		95701-06012-08	0	BOLT FLANGE 6*12	螺絲 6*12	1	
		95701-06014-08	0	BOLT FLANGE 6*14	螺絲 6*14	2	
		96001-06014-08	0	BOLT FLANGE SH 6*14	螺絲 6*14	2	

F 11 Battery

電
瓶

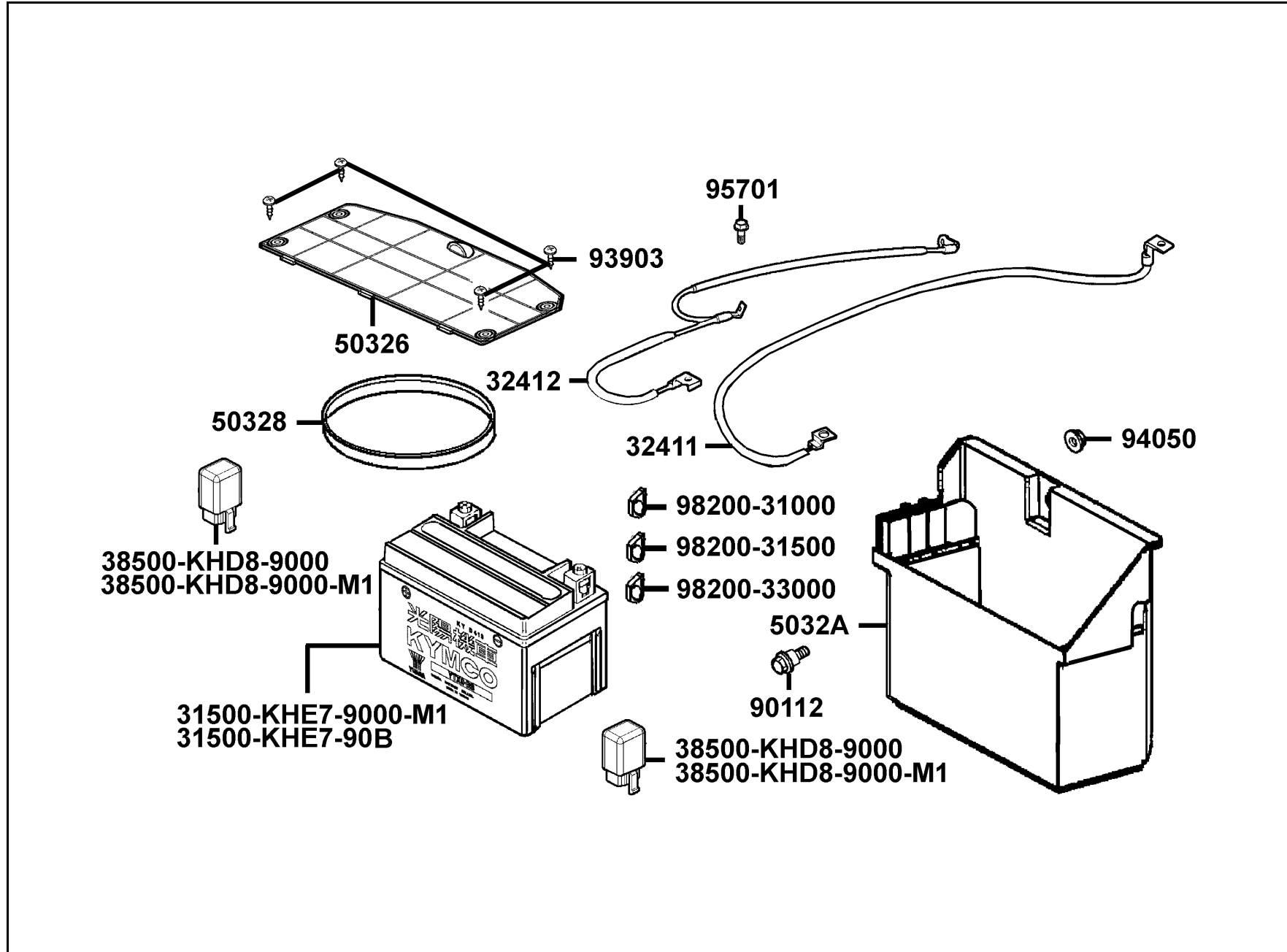

販賣記號 Sales mark	項目 Ref no	零件號碼 Part no	版數 Ver	英文名稱 Description	中文名稱 Chinese	需要用量 Regd no	參考價 Ref Price
		31500-KHE7-9000-M1	0	BATTERY YTX12-BS	電瓶	1	
		31500-KHE7-90B	2	BATTERY GTX12-BS	電瓶	1	
		32411-KKC4-9000	0	CABLE BATTERY	電瓶導線	1	
		32412-KKC4-900	2	CABLE EARTH	電瓶接地線	1	
		38500-KHD8-9000	0	RELAY ASSY LIGHT	繼電器	2	
		38500-KHD8-9000-M1	0	RELAY ASSY LIGHT	繼電器	2	
**		50326-KKC4-900	0	COVER BATTERY	電瓶盒蓋	1	
		50328-KBN-2000	0	BAND BATTERY	電瓶束帶	1	
		5032A-KKC4-9000	0	CASE ASSY BATTERY	電瓶箱	1	
		90112-KBN-9010	0	BOLT FLANGE 6MM	螺絲 6MM	1	
		93903-GY6-9000	0	SCREW TAPPING 4*14	螺釘 4*14	4	
		94050-06080	0	NUT FLANGE 6MM	螺帽 6MM	1	
		95701-06012-08	0	BOLT FLANGE 6*12	螺絲 6*12	1	
		98200-31000	0	BLADE FUSE 10A	保險絲 10A	1	
		98200-31500	0	BLADE FUSE 15A	保險絲 15A	1	
		98200-33000	0	BLADE FUSE 30A	保險絲 30A	1	

F 12

Body Cover●Luggage Box

車體蓋 ● 行李箱

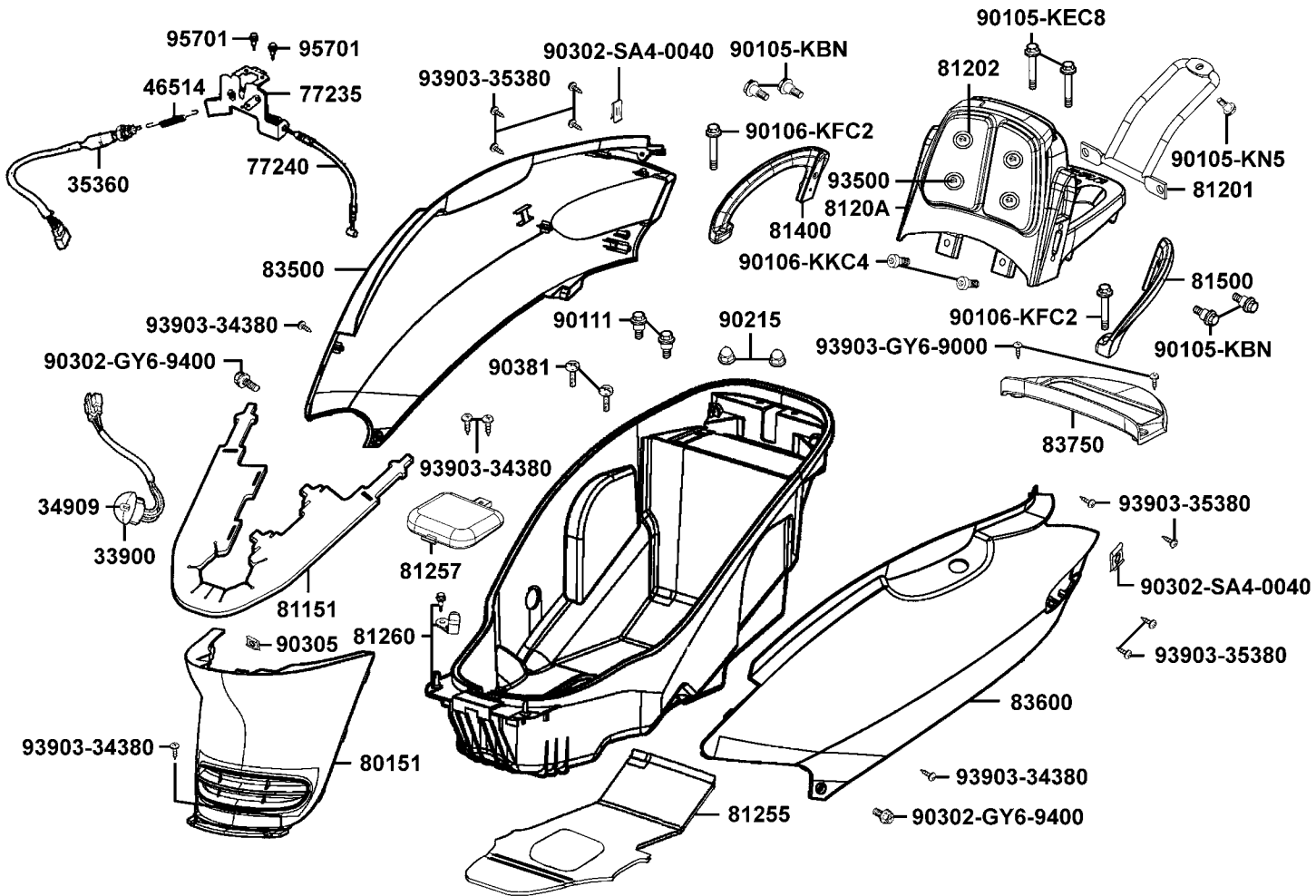

販賣記號 Sales mark	項目 Ref no	零件號碼 Part no	版數 Ver	英文名稱 Description	中文名稱 Chinese	需要用量 Regd no	參考價 Ref Price
		33900-KBF-9000	0	LIGHT ASSY LUGGAGE BOX	行李箱照明燈	1	
		34909-KBF-9000	0	BULB WEDGE BASE	燈泡	1	
		35360-KBF-9000	1	SW UNIT LUGGAGE BOX LIGHT	行李箱燈開關	1	
		46514-KBF-9000	0	SPRING STOP SWITCH	置物箱開關彈簧	1	
		77235-KKC4-9000	0	CATCH COMP SEAT	座墊檔器	1	
		77240-KKC4-9000	1	CABLE COMP SEAT LOCK	座墊鎖導線	1	
**		80151-KKC4-900	0	COVER CENTER	中心蓋	1	
		81151-KKC4-9000	0	PLATE HEAT GUARD	防熱板	1	
		81201-KKC4-900	1	POWER BAR RR CARRIER	後架拉柄	1	
		81202-KKC4-900	0	UNBRELLALIKE CLASP	後座座墊連接套筒	4	
**		8120A-KKC4-900	6	CARRIER ASSY RR	後架	1	
		81255-KKC4-9000	0	BAG LUGGAGE	置物箱內襯	1	
		81257-KKC4-800	0	COVER CARB MAINT	汽化器保養蓋	1	
		81260-KKC4-9000	1	BOX ASSY LUGGAGE	行李箱組	1	
**		81400-KKC4-900	0	SIDE R GRIP	右握桿	1	
**		81500-KKC4-900	0	SIDE L GRIP	左握桿	1	
**		83500-KKC4-900	0	COVER R BODY	車體右邊蓋	1	
**		83600-KKC4-900	1	COVER L BODY	車體左邊蓋	1	
**		83750-KKC4-900	1	COVER RR CENTER	後中心蓋	1	
		90105-KBN-9010	0	BOLTSPECIAL 8MM	螺絲 8MM	4	

F 12 Body Cover●Luggage Box

車體蓋 ● 行李箱

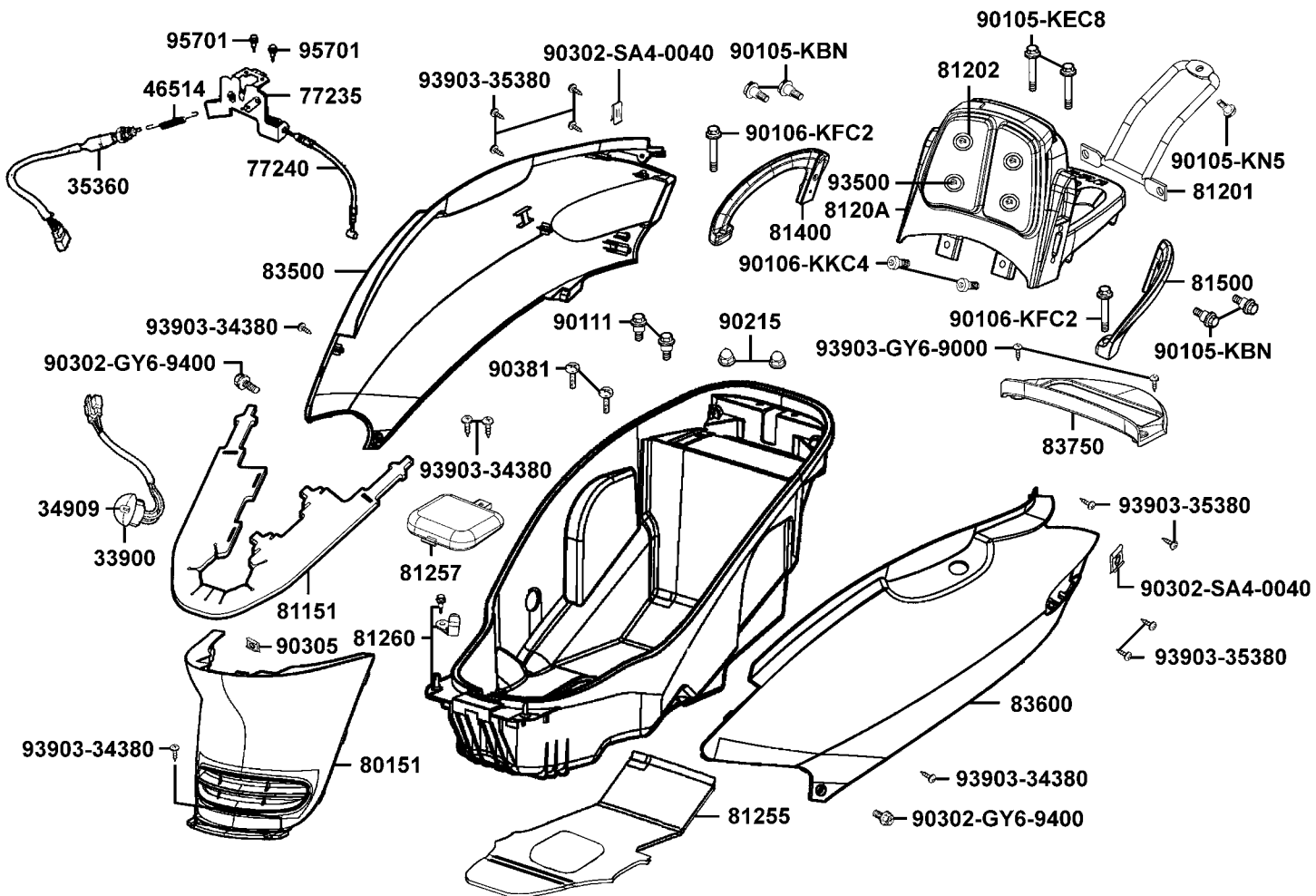

F12

販賣記號 Sales mark	項目 Ref no	零件號碼 Part no	版數 Ver	英文名稱 Description	中文名稱 Chinese	需要用量 Regd no	參考價 Ref Price
		90105-KEC8-9000	0	BOLT WASHER 8MM	螺絲 8MM	2	
		90105-KN5-0010	0	BOLT DISK 6*17	螺絲 6*17	1	
		90106-KFC2-9000	0	BOLT WASHER 8MM	螺絲 8MM	2	
		90106-KKC4-900	0	BOLT WASH 8MM	特殊螺絲 8MM	2	
		90111-187-0000	1	BOLT FLANGE 6MM	螺絲 6MM	2	
		90215-KKC4-900	0	NUT CAP 6MM	螺帽 6MM	2	
		90302-GY6-9400	0	BOLT WASH 5*16	螺絲 5*16	2	
		90302-SA4-0040	1	NUT SPRING 4MM	夾螺帽 4MM	2	
		90305-GK8-0010	0	NUT CLIP 6MM	夾螺帽 6MM	1	
		90381-GZ5-0010	0	SCREW SPECIAL 6*17	特殊螺絲 6*17	2	
		93500-04012-0H	0	SCREW 4*12	螺絲 4*12	4	
		93903-34380	0	SCREW TAPPING 4*12	螺釘 4*12	6	
		93903-35380	0	SCREW TAPPING 5*16	螺釘 5*16	8	
		93903-GY6-9000	0	SCREW TAPPING 4*14	螺釘4*14	2	
		95701-06012-08	0	BOLT FLANGE 6*12	螺絲 6*12	2	

F 13 Air Cleaner

空氣濾清器

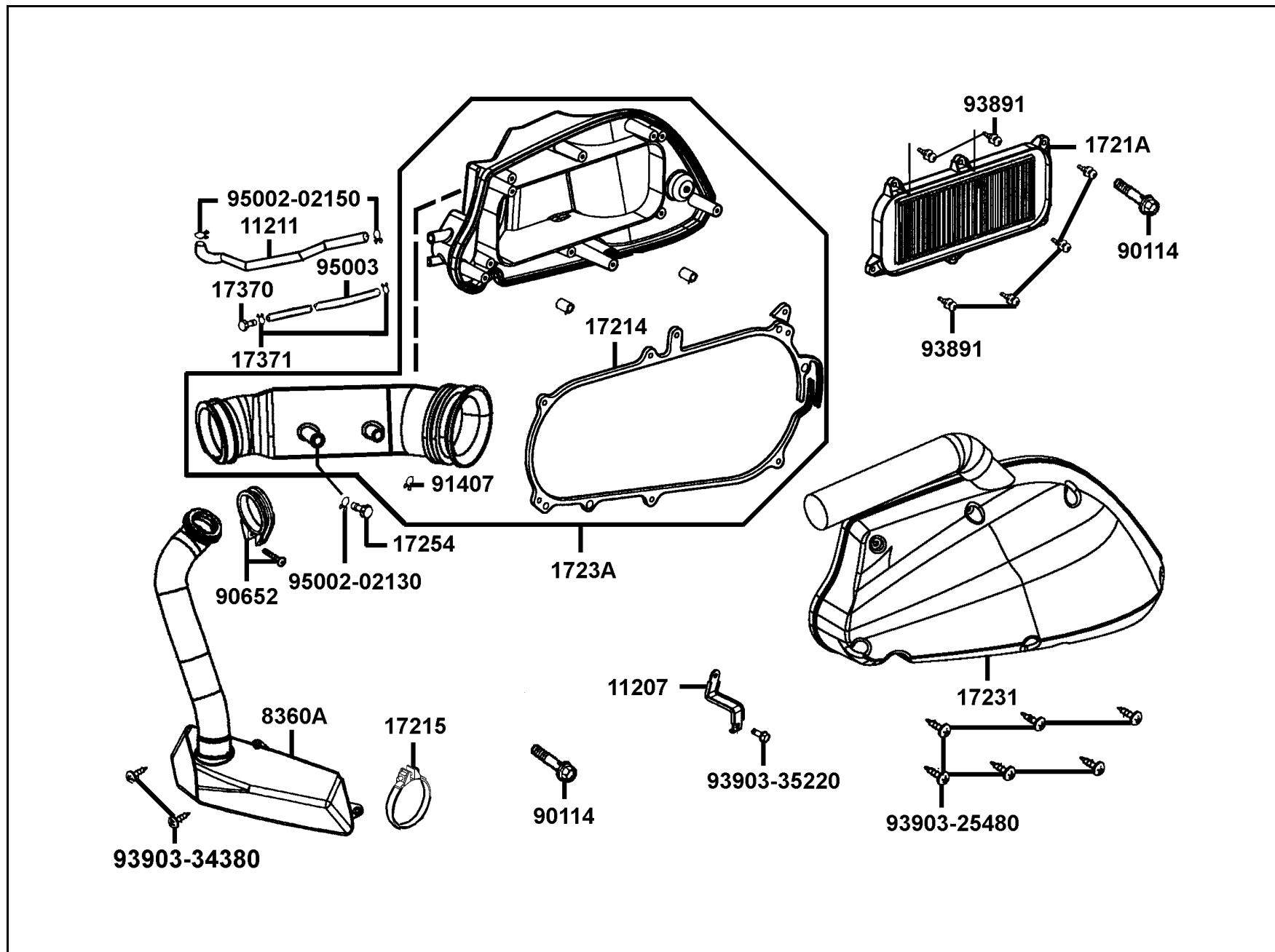

販賣記號 Sales mark	項目 Ref no	零件號碼 Part no	版數 Ver	英文名稱 Description	中文名稱 Chinese	需要用量 Regd no	參考價 Ref Price
		11207-KKC4-9000	3	STAY RR FENDER	後土除支架	1	
		11211-KKC4-9000	0	TUBE BREATHER	通氣管	1	
		17214-KKC3-9000	0	SEAL AIR/C COVER	空氣濾清器蓋油封	1	
		17215-KGBG-9000	0	CLIP ASSY AIR/C DUCT	固定管夾	1	
		1721A-KKC3-9000	1	ELEMENT ASSY AIR/C	空氣濾清器海綿組	1	
		17231-KKC3-900	1	COVER COMP AIR/C	空氣濾清器蓋	1	
		1723A-KKC4-E00	2	CASE ASSY AIR/C	空氣濾清器箱組	1	
		17254-KCA-P000	0	PLUG AIR/C CONN TUBE	管塞	1	
		17370-419-7010	0	PLUG BREATHER TUBE	管塞	1	
		17371-174-6700	0	CLIP BREATHER TUBE	通氣管夾	2	
		8360A-KKC4-9000	0	CHAMBER ASSY AIR/C	空氣室組	1	
		90114-GM4-0110	1	BOLT FLANGE SH 6*28	螺絲 6*28	2	
		90652-KHE7-9000	0	BAND CONNECTING TUBE	連接管固定帶	1	
		91407-SA7-0040	0	CLAMP 17 FUSE HOSE	油管夾	1	
		93891-05016-08	0	SCREW WASHER 5*16	螺絲 5*16	6	
		93903-25480	0	SCREW TAPPING 5*20	螺釘 5*20	6	
		93903-34380	0	SCREW TAPPING 4*12	螺釘 4*12	2	
		93903-35220	0	SCREW TAPPING 5*12	螺釘 5*12	1	
		95002-02130	0	CLIP B 12.5 TUBE	管夾	1	
		95002-02150	0	CLIP B14.5 TUBE	管夾	2	

F 13 Air Cleaner

空氣濾清器

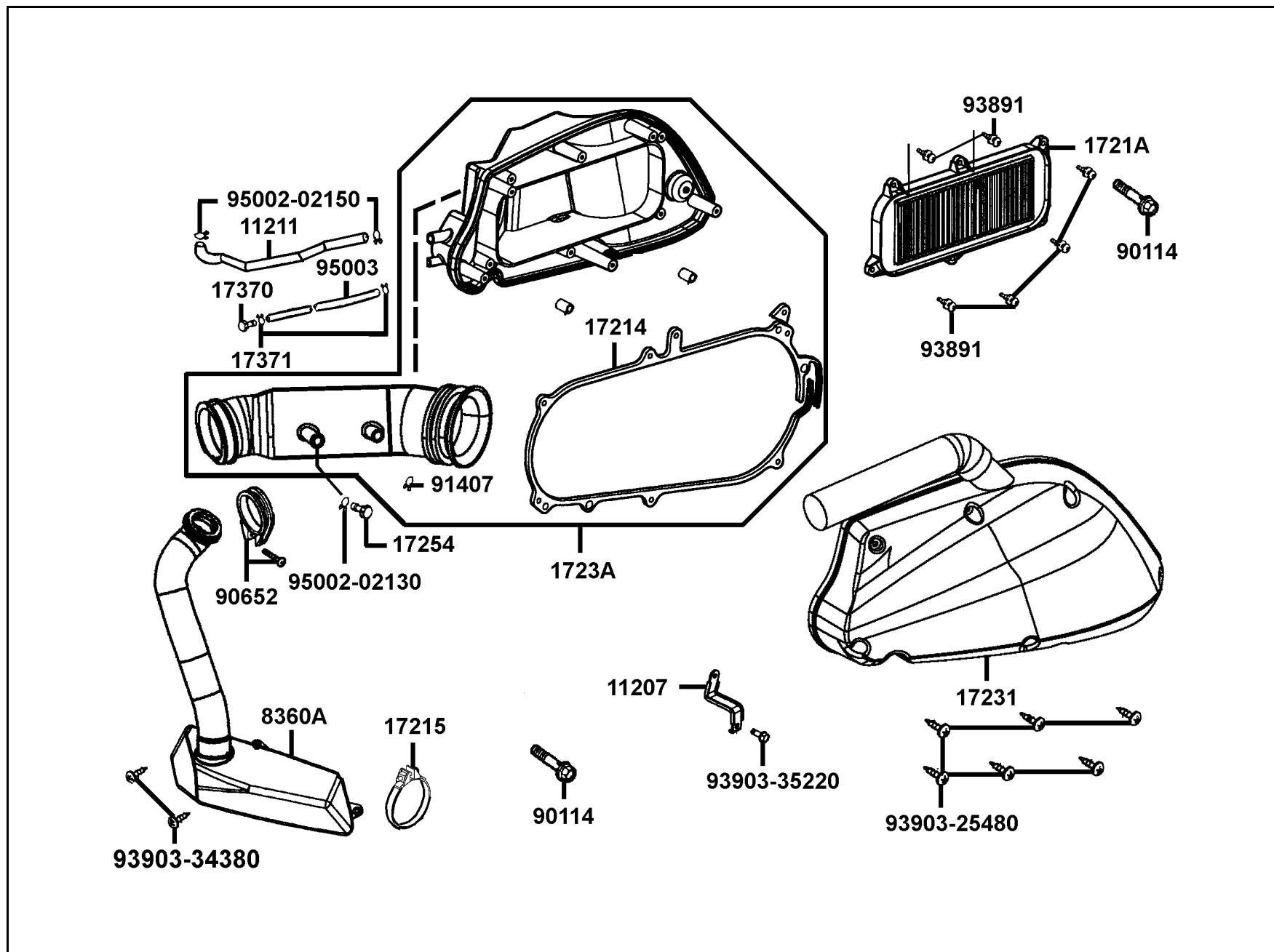

販賣記號 Sales mark	項目 Ref no	零件號碼 Part no	版數 Ver	英文名稱 Description	中文名稱 Chinese	需要用量 Regd no	參考價 Ref Price
		95003-23031-60	0	V TUBE 8*12*310	通氣管	1	

F13

F 14 Exhaust Muffler

排氣管

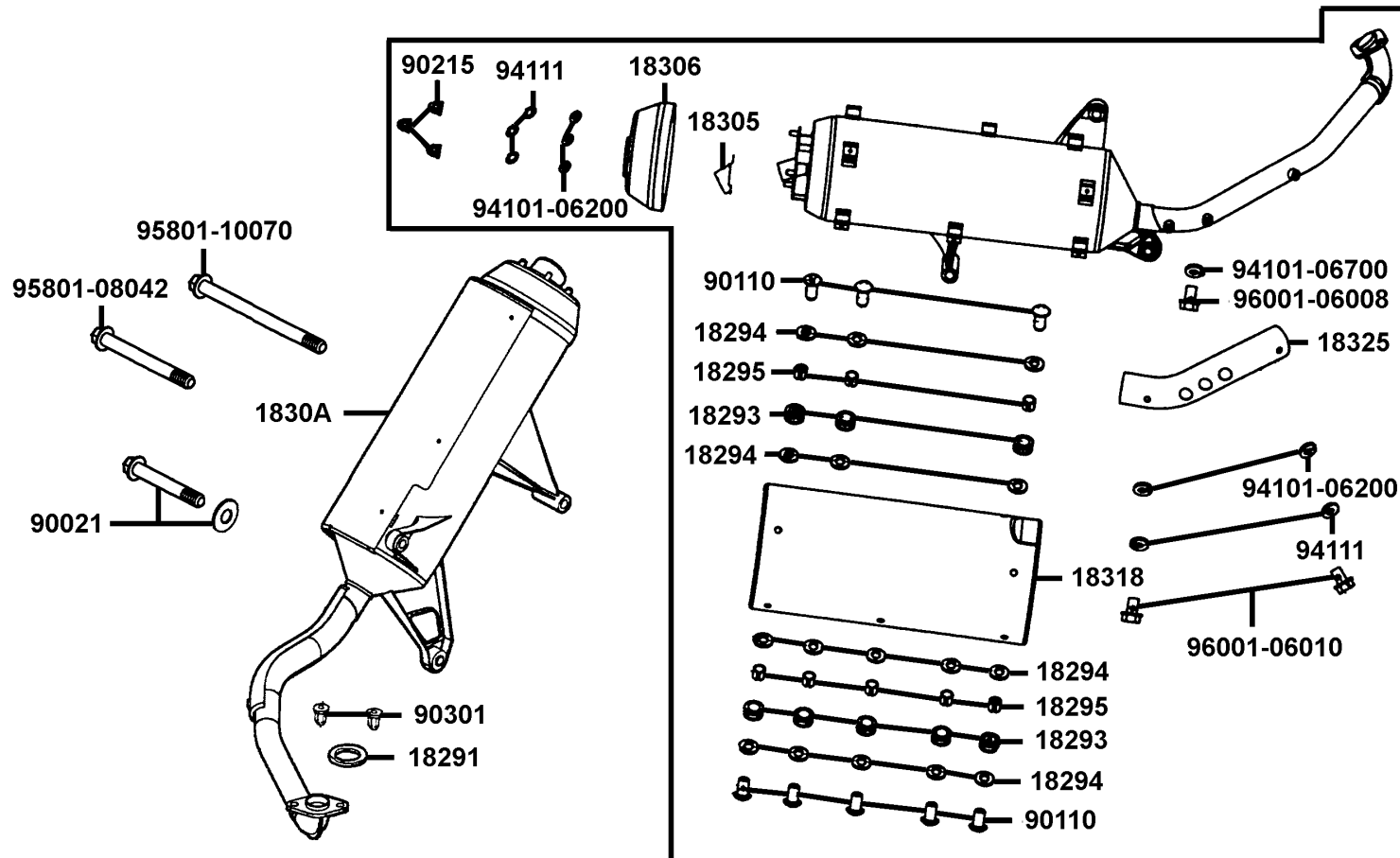

F14

販賣記號 Sales mark	項目 Ref no	零件號碼 Part no	版數 Ver	英文名稱 Description	中文名稱 Chinese	需要用量 Regd no	參考價 Ref Price
		18291-166-0040	0	GASKET EXH PIPE	排氣管墊圈	1	
		18293-KCE-9000	0	RUBBER A PROTR	橡皮	8	
		18294-KBE-9000	0	PACKING PROTECTOR	墊片	16	
		18295-KCE-9000	0	COLLAR M6	套筒 6MM	8	
		18305-KHD8-9000	0	PROTECTOR TAIL PIPE	排氣管後護板座	1	
		18306-KHE7-9000	0	TAIL CAP MUFFLER	排氣管尾蓋	1	
		1830A-KHE7-EZ0	1	MUFFLER ASSY EXH	排氣管組	1	
		18318-KHE7-E000	0	PROTECTOR MUFFLER	排氣管護蓋	1	
		18325-KHE7-9000	1	PROTECTOR EXH PIPE	排氣連接管護蓋	1	
		90021-GY6-9000	0	BOLT WASHER COMP	螺絲	1	
		90110-KHD8-9000	0	SCREW SPECIAL 6*20	特殊螺絲 6*20	8	
		90215-GM0-9100	0	NUT CAP 6MM	螺帽 6MM	3	
		90301-GY6-9010	1	NUT (HEX) CAP 8MM	圓螺帽 8MM	2	
		94101-06200	0	WASHER PLAIN 6MM	華司 6MM	5	
		94101-06700	0	WASHER PLAIN 6MM	平華司 6MM	1	
		94111-06800	0	WASHER SPRING 6MM	彈簧華司 6MM	5	
		95801-08042-07	0	BOLT FLANGE 8*42	螺絲 8*42	1	
		95801-10070-07	0	BOLT FLANGE 10*70	螺絲 10*70	1	
		96001-06008-07	0	BOLT FLANGE SH 6*8	螺絲 6*8	1	
		96001-06010-08	0	BOLT FLANGE SH 6*10	螺絲 6*10	2	

F 15 Stand●Kick Starter Arm

腳架
●
起動踏桿

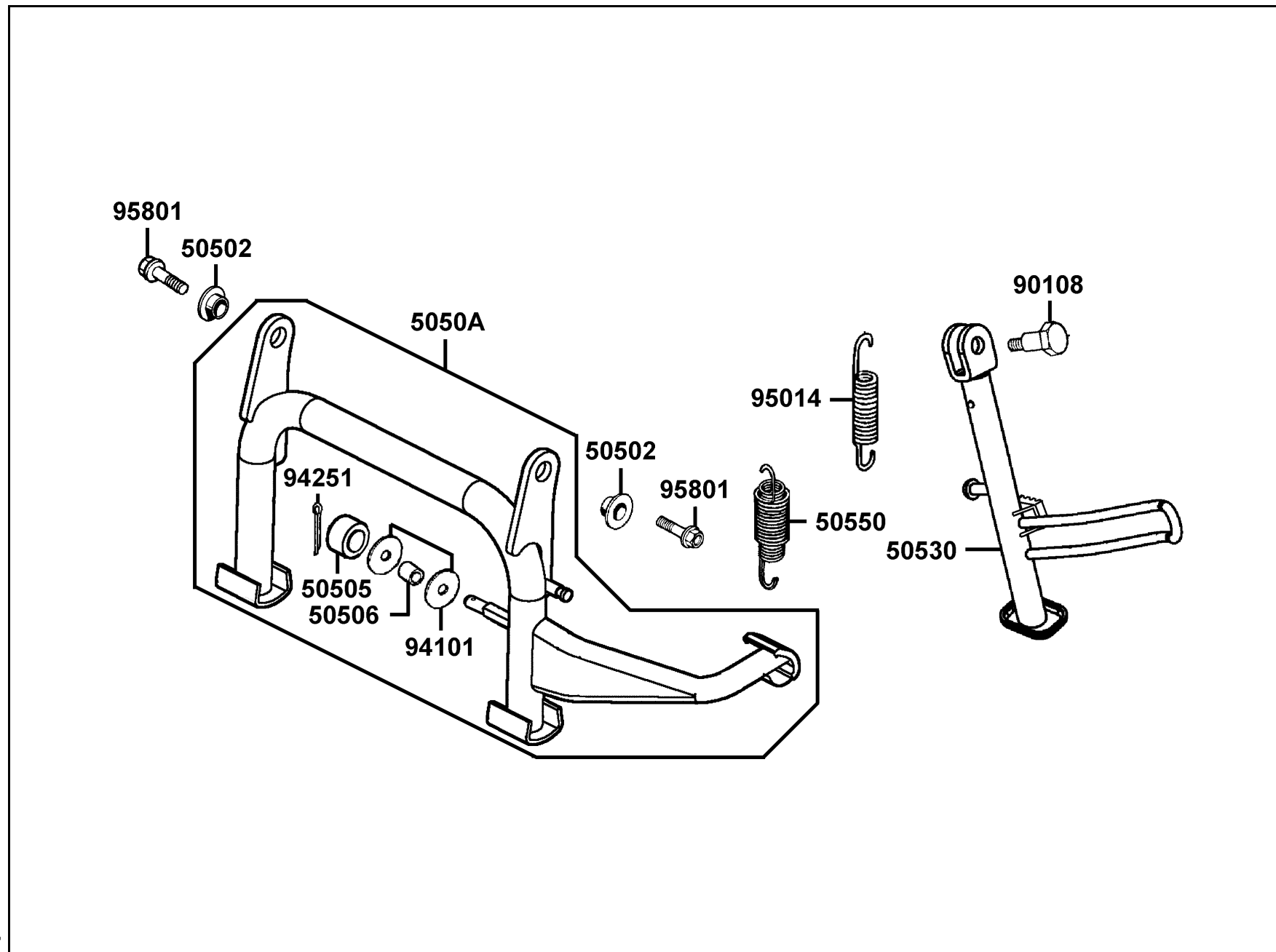

F15

販賣記號 Sales mark	項目 Ref no	零件號碼 Part no	版數 Ver	英文名稱 Description	中文名稱 Chinese	需要用量 Regd no	參考價 Ref Price
		50502-GY6-9010	0	COLLAR MAIN STAND	主腳架套環	2	
		50505-KHE7-E000	0	STOPPER RUBBER	主腳架橡皮	1	
		50506-KHE7-E000	0	COLLAR STOPPER RUBBER	套筒	1	
		5050A-KKC4-9000	1	STAND ASSY MAIN	主腳架組	1	
		50530-KKC4-900	1	BAR SIDE STAND	側腳架	1	
		50550-KEB7-E000	1	SPRING ASSY MAIN STAND	主腳架彈簧	1	
		90108-KKC4-900	0	SCREW SIDE STAND PIVOT	側腳架螺絲	1	
		94101-08700	0	WASHER PLAIN 8MM	華司	2	
		94251-08400	0	PIN LOCK 8MM	固定銷 8MM	1	
		95014-72204	0	SPRING B1 SIDE STAND	側腳架彈簧	1	
		95801-10025-08	0	BOLT FLANGE 10*25	螺絲 10*25	2	

F 16 Rear Cushion

後
避
震
器

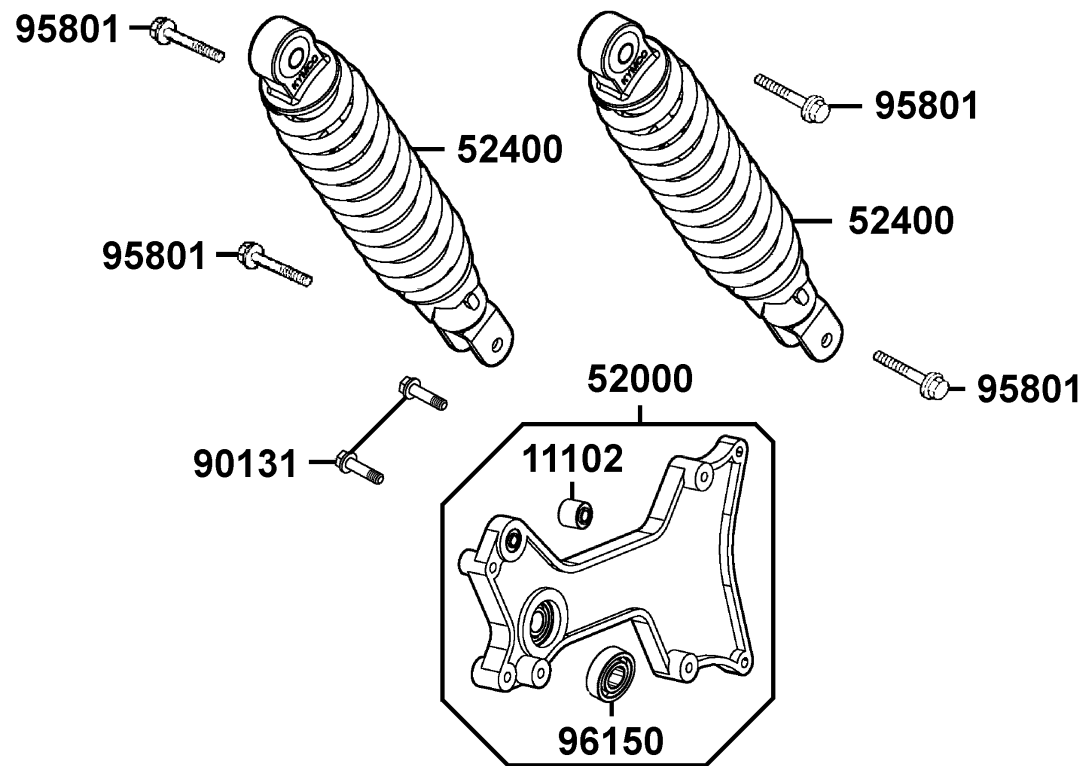

F16

販賣記號 Sales mark	項目 Ref no	零件號碼 Part no	版數 Ver	英 文 名 稱 Description	中 文 名 稱 Chinese	需要用量 Regd no	參考價 Ref Price
		11102-187-0030	3	RUB BUSH ENG HANGER	引擎吊架襯套	1	
**		52000-KKC4-900	0	FORK ASSY REAR	後叉	1	
**		52400-KKC4-900	3	CUSHION ASSY R RR	後右避震器	2	
		90131-KAF-9000	0	BOLT FLANGE 8*42	螺絲 8*42	2	
		95801-10035-08	0	BOLT FLANGE 10*35	螺絲 10*35	4	
		96150-62040-10	0	BEARING BALL RADIAL 6204	後叉軸承	1	

F 17 Front Winker

前
方
向
燈

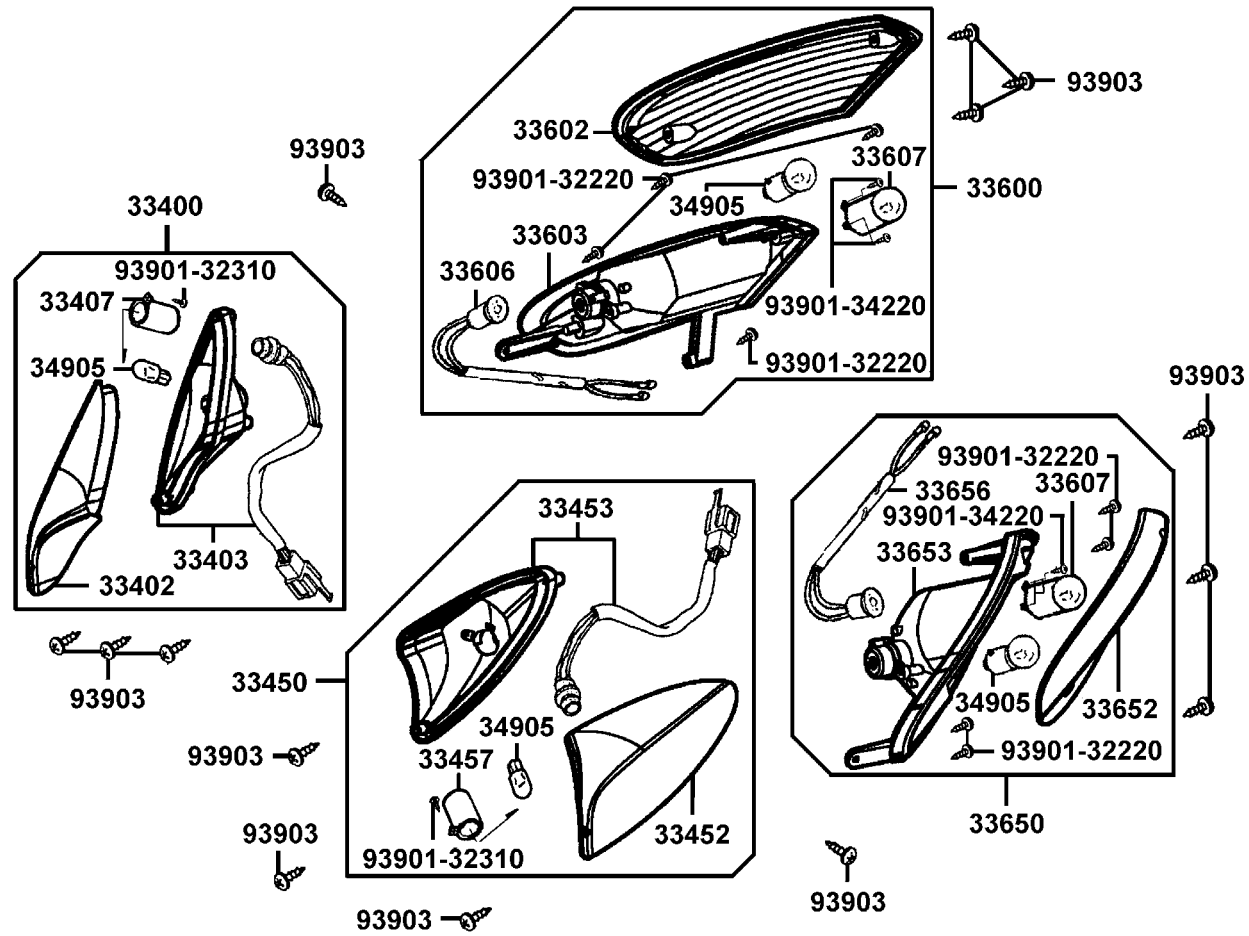

販賣記號 Sales mark	項目 Ref no	零件號碼 Part no	版數 Ver	英文名稱 Description	中文名稱 Chinese	需要用量 Regd no	參考價 Ref Price
		33400-KKC4-E000	0	WINKER ASSY R FR	右前方向燈組	1	
		33402-KKC4-E000	0	LENS R FR WINKER	右前方向燈殼	1	
		33403-KKC4-E000	0	BASE COMP R FR WINKER	右前方向燈座	1	
		33407-KKC4-E000	0	INNER LENS WINKER R	右前方向燈內燈殼	1	
		33450-KKC4-E000	0	WINKER ASSY L FR	左前方向燈組	1	
		33452-KKC4-E000	0	LENS L FR WINKER	左前方向燈殼	1	
		33453-KKC4-E000	0	BASE COMP L FR WINKER	左前方向燈座	1	
		33457-KKC4-E000	0	INNER LENS WINKER L	左前方向燈內燈殼	1	
		33600-KKC4-E000	2	WINKER ASSY R RR	右後方向燈組	1	
		33602-KKC4-E000	0	LENS R RR WINKER	右後方向燈殼	1	
		33603-KKC4-E000	0	BASE R RR WINKER	右後方向燈座	1	
		33606-KKC4-E000	0	SOCKET COMP R RR WINKER	右後方向燈配線	1	
		33607-KKD7-E000	0	INNER LENS WINKER	後方向燈內燈殼	2	
		33650-KKC4-E000	1	WINKER ASSY L RR	左後方向燈組	1	
		33652-KKC4-E000	0	LENS L RR WINKER	左後方向燈殼	1	
		33653-KKC4-E000	0	BASE L RR WINKER	左後方向燈座	1	
		33656-KKC4-E000	0	SOCKET COMP L RR WINKER	左後方向燈配線	1	
		34905-KCP-9000	0	BULB WINKER	方向燈泡	4	
		93901-32220	0	SCREW TAPPING 3*10	螺釘 3*10	8	
		93901-32310	0	SCREW TAPPING 3*12	螺釘 3*12	2	

F 17 Front Winker

前
方
向
燈

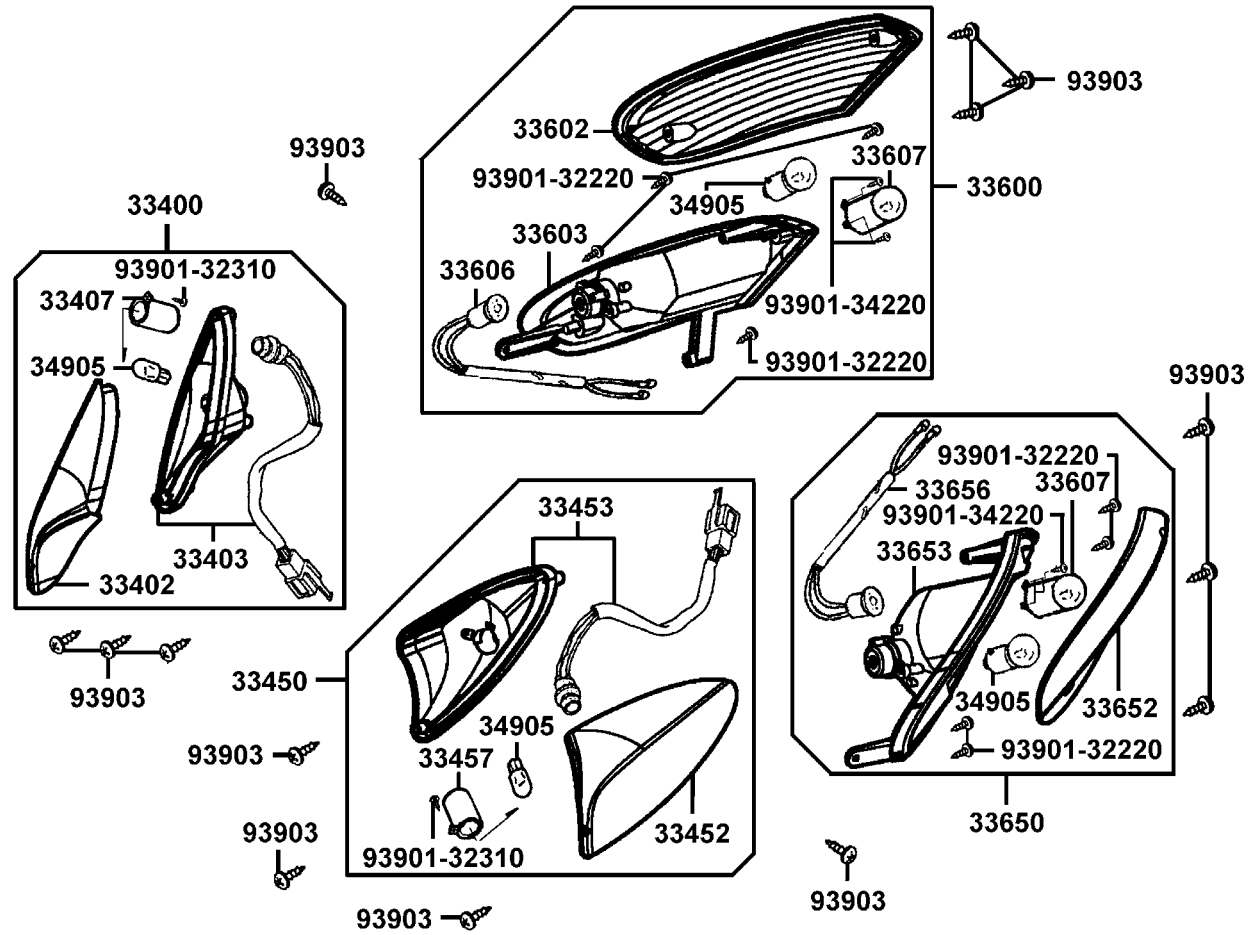

販賣記號 Sales mark	項目 Ref no	零件號碼 Part no	版數 Ver	英 文 名 稱 Description	中 文 名 稱 Chinese	需要用量 Regd no	參考價 Ref Price
		93901-34220	0	SCREW TAPPING 4*10	螺釘 4*10	4	
		93903-34380	0	SCREW TAPPING 4*12	螺釘 4*12	14	

F17

F 18

Rear Light●Rear Fender

後
燈
●
後
土
除

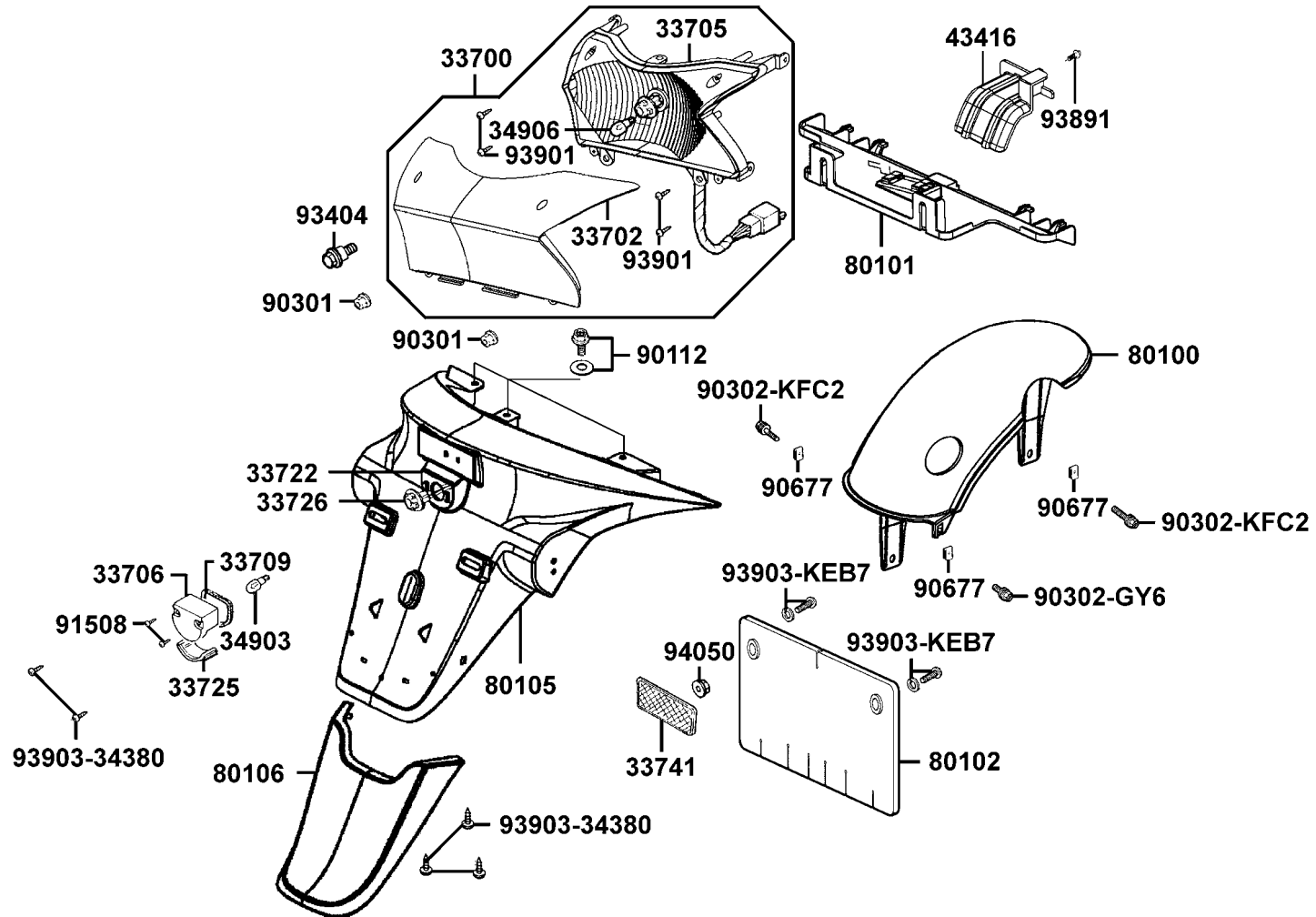

F18

販賣記號 Sales mark	項目 Ref no	零件號碼 Part no	版數 Ver	英文名稱 Description	中文名稱 Chinese	需要用量 Regd no	參考價 Ref Price
		33700-KKC4-E000	0	LIGHT ASSY RR TAIL	後燈組	1	
		33702-KKC4-E000	0	LENS TAIL LIGHT	後燈殼	1	
		33705-KKC4-E000	0	BASE COMP TAIL LIGHT	後燈座	1	
		33706-KHB4-E10	0	COVER LICENSE	牌照燈蓋	1	
		33709-KAB-0030	0	PACKING LICENSE	牌照燈蓋墊圈	1	
		33722-KHB4-E000	0	BASE LICENSE	牌照燈座	1	
		33725-KHB4-E000	0	LENS LICENSE	牌照燈殼	1	
		33726-KHB4-E000	0	SOCKET COMP	牌照燈配線	1	
		33741-KBE-9000	0	REFLEX REFLECTOR	反光鏡片	1	
		34903-KCP-9000	0	BULB POSITION	位置燈燈泡	1	
		34906-KCP-9000	0	BULB TAIL & STOP	後燈燈泡	1	
		43416-KKC4-900	0	GUARD RR CALIPER	後煞車卡鉗護蓋	1	
		80100-KKC4-900	3	FENDER RR TIRE	後輪上土除	1	
		80101-KKC4-900	1	FENDER RR UP	後上土除	1	
		80102-KKC4-900	2	PLATE C SPLASH GUARD	防濺板 C	1	
		80105-KKC4-9000	1	FENDER RR	後土除	1	
		80106-KKC4-9000	0	FENDER B RR	後土除 B	1	
		90112-KBN-9010	0	BOLT FLANGE 6MM	螺絲 6MM	3	
		90301-634-6700	0	MUT FLANGE 6MM	螺帽 6MM	2	
		90302-GY6-9400	0	BOLT WASHER 5*16	螺絲 5*16	1	

F 18

Rear Light●Rear Fender

後
燈
●
後
土
除

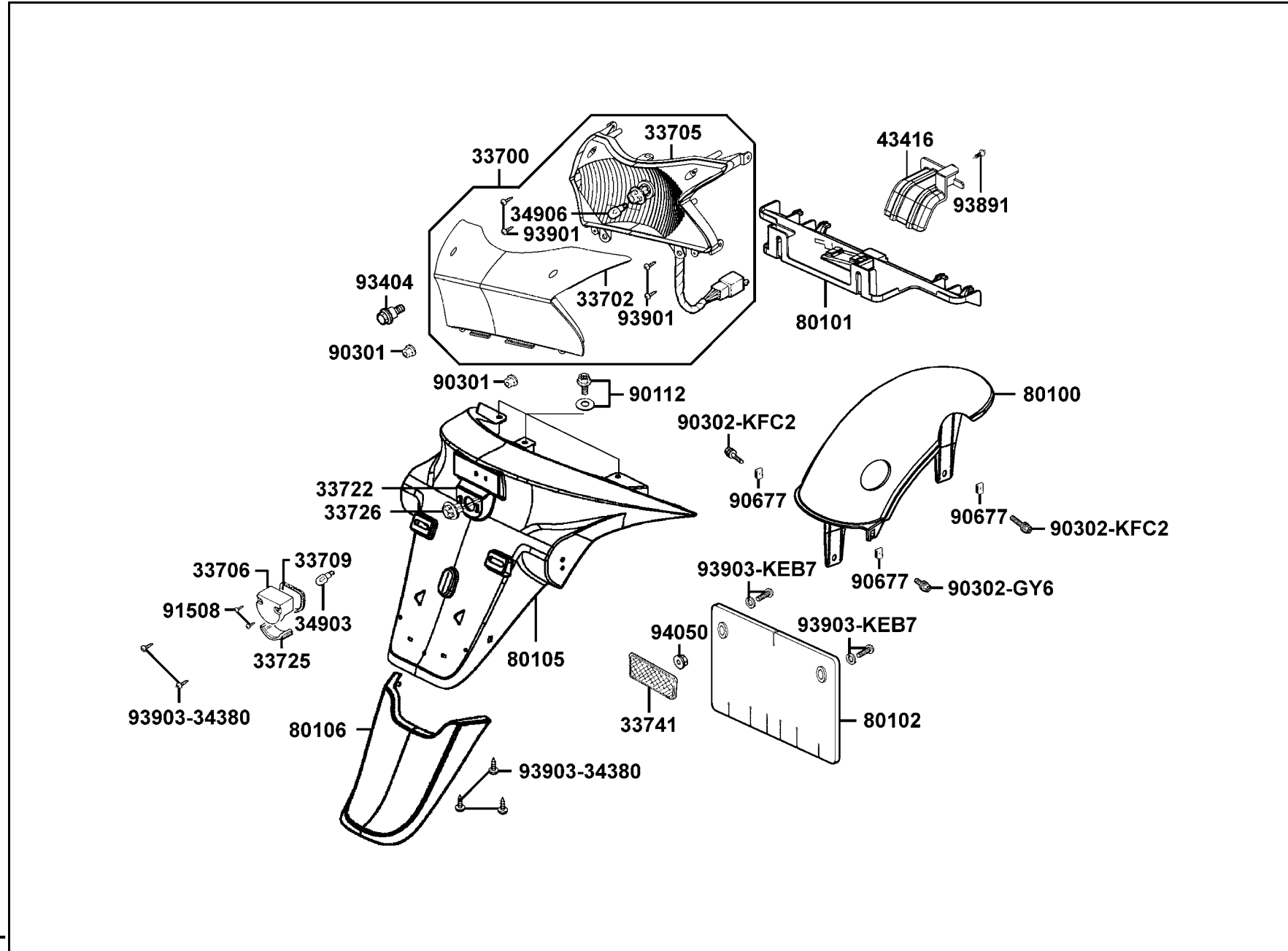

F18

販賣記號 Sales mark	項目 Ref no	零件號碼 Part no	版數 Ver	英文名稱 Description	中文名稱 Chinese	需要用量 Regd no	參考價 Ref Price
		90302-KFC2-9000	0	BOLT WASHER 5*25	螺絲 5*25	2	
		90677-GR1-0030	1	NUT CLIP 5MM	帽夾 5MM	3	
		91508-KV7-6710-M1	0	SCREW TAPPING 4*14	螺釘 4*14	2	
		93404-06016-07	0	BOLT WASHER 6*16	螺絲 6*16	1	
		93891-05030-07	0	SCREW WASHER 5*30	螺絲 5*30	1	
		93901-34320	0	SCREW TAPPING 4*12	螺釘 4*12	4	
		93903-34380	0	SCREW TAPPING 4*12	螺釘 4*12	5	
		93903-KEB7-9000	0	SCREW WASHER 4MM	螺絲 4MM	2	
		94050-05080	0	NUT FLANGE 5MM	螺帽 5MM	1	

F 19 Wire Harness

主
電
路
配
線

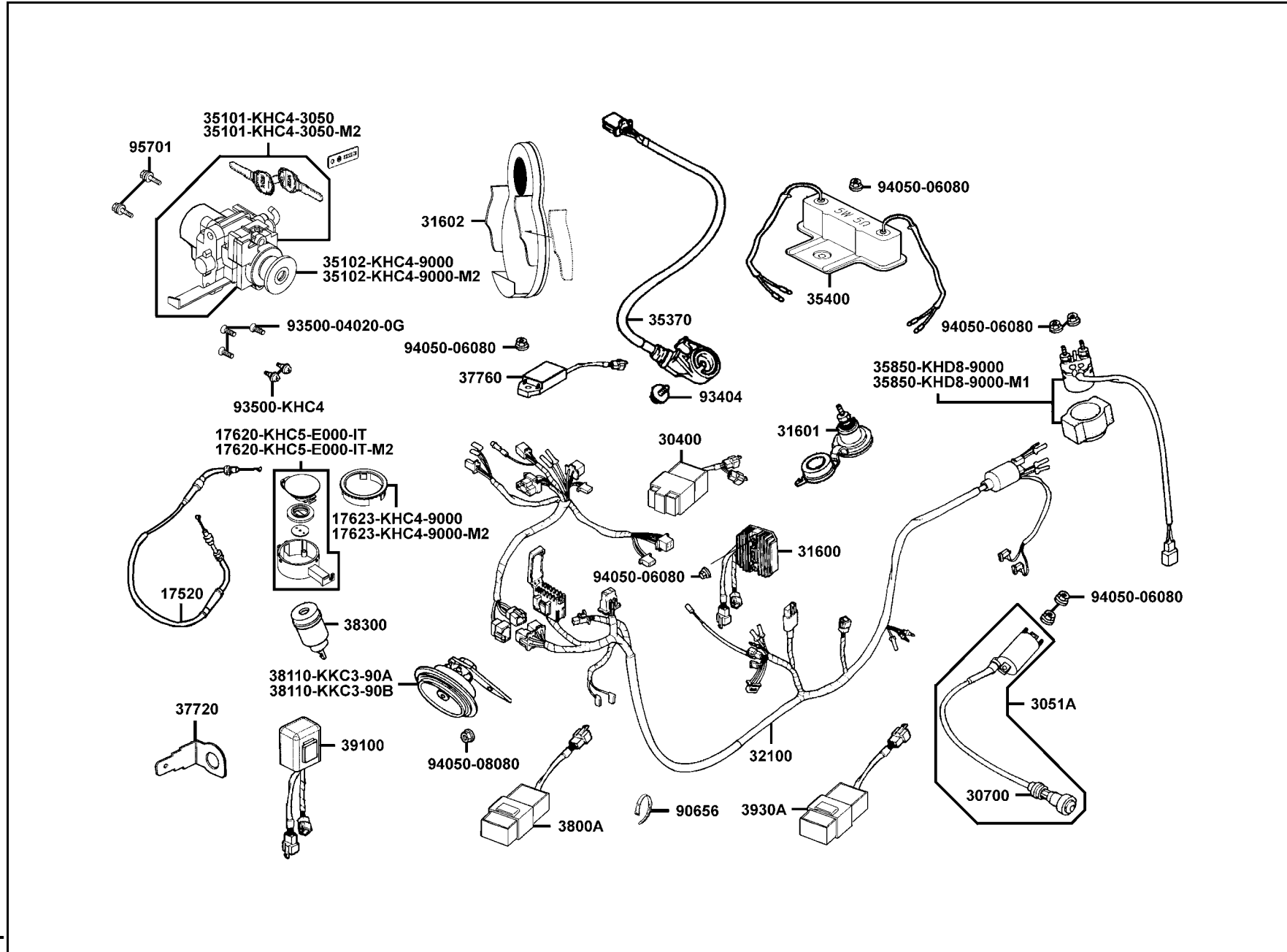

販賣記號 Sales mark	項目 Ref no	零件號碼 Part no	版數 Ver	英文名稱 Description	中文名稱 Chinese	需要用量 Regd no	參考價 Ref Price
		17520-KKC4-9000	0	CABLE COMP FUEL CAP	油箱蓋導線	1	
		17620-KHC5-E000-IT	0	CAP COMP FUEL FILLER	油箱蓋	1	
		17620-KHC5-E000-IT-M2	1	CAP COMP FUEL FILLER	油箱蓋	1	
		17623-KHC4-9000	6	COLLAR FUEL CAP	油箱蓋套筒	1	
		17623-KHC4-9000-M2	1	COLLAR FUEL CAP	油箱蓋套筒	1	
		30400-KHE7-900	2	UNIT CDI	C.D.I.組	1	
		3051A-KKC4-9000	0	COIL ASSY IGNITION	點火線圈	1	
		30700-KFC8-E000-M8	1	CAP ASSY NOISE SUPPRESSOR	火星塞蓋	1	
		31600-KM1-009	9	REG REC COMP	整流器	1	
		31601-KKC4-900	3	SOCKET COMP DC 12V	手機充電座	1	
		31602-KKC4-9000	0	SOCKET COMP CELL-PHONE	手機固定座	1	
		32100-KKC4-E10	4	HARNESS WIRE	主配線	1	
		35101-KHC4-3050	5	SW SET COMB & LOCK	主開關	1	
		35101-KHC4-3050-M2	0	SW SET COMB & LOCK	主開關	1	
		35102-KHC4-9000	2	COLLAR MAIN SW	主開關指示器套筒	1	
		35102-KHC4-9000-M2	0	COLLAR MAIN SW	主開關指示器套筒	1	
		35370-KEC8-E000	1	SW UNIT SIDE STAND	側腳架開關	1	
		35400-KHE7-900	1	RESISTOR COMP	電阻器組	1	
		35850-KHD8-9000	1	SET START MAG	起動開關組	1	
		35850-KHD8-9000-M1	0	SET START MAG	起動開關組	1	

F 19 Wire Harness

主
電
路
配
線

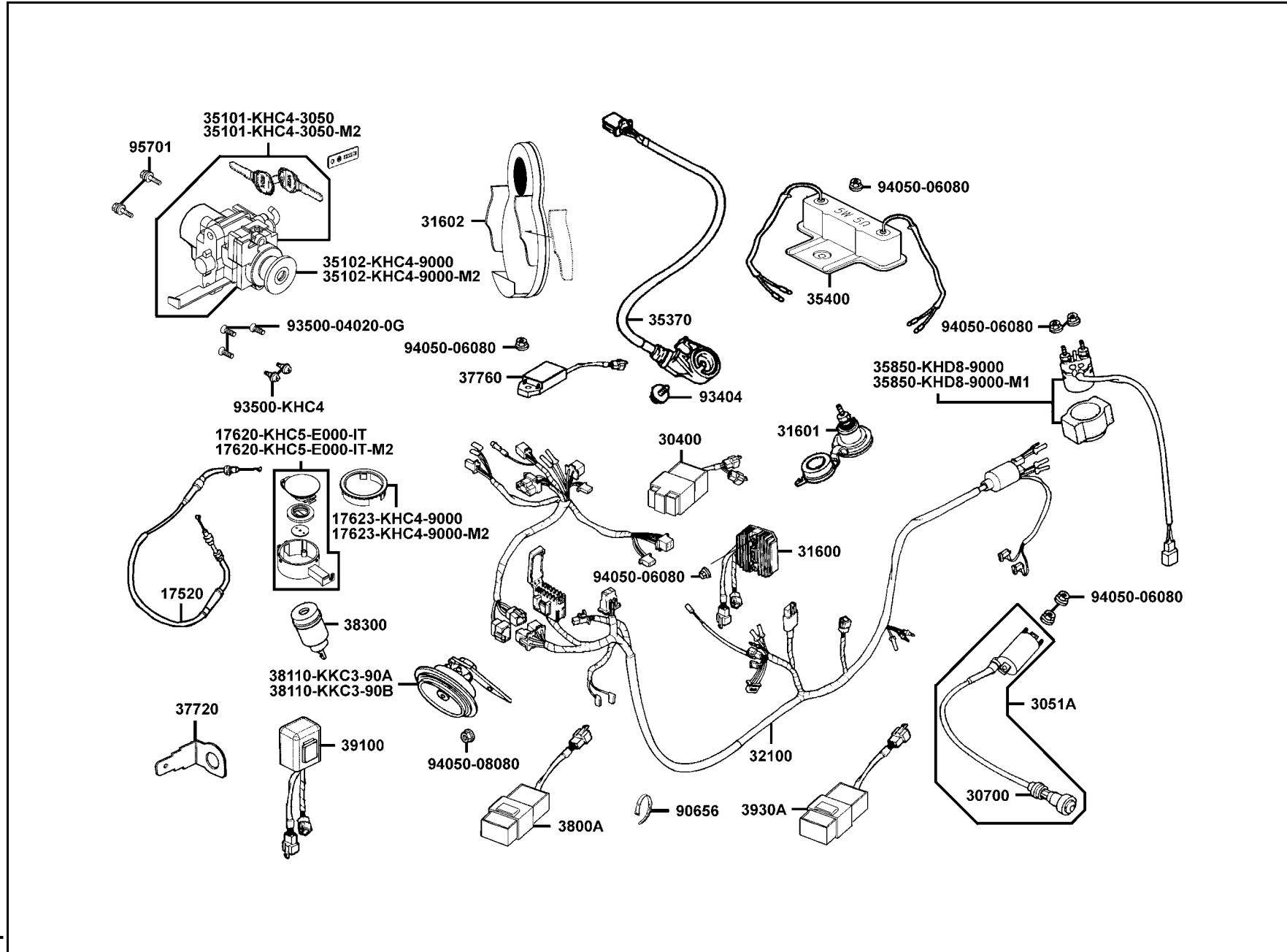

販賣記號 Sales mark	項目 Ref no	零件號碼 Part no	版數 Ver	英文名稱 Description	中文名稱 Chinese	需要用量 Regd no	參考價 Ref Price
		37720-KGBG-E000	0	EARTH TERMINAL HEATER	接地板	1	
		37760-KGBG-E100	0	UNIT HEATER CONTROL	加熱控制器	1	
		3800A-KKC4-900	1	UNIT ASSY ENG STOP	引擎斷電器	1	
		38110-KKC3-90A	1	HORN COMP	喇叭	1	
		38110-KKC3-90B	1	HORN COMP	喇叭	1	
		38300-KCE-9000	1	RELAY ASSY WINKER	方向燈繼電器	1	
		39100-KHD8-9000	0	EMI FILTER MOTOR	風扇馬達濾波器	1	
		3930A-KKC4-900	2	BACK MIRROR CTRL ASSY	後視鏡控制組	1	
		90656-KDU-9000	0	BAND HARNESS WIRE	配線束帶	1	
		93404-06016-07	0	BOLT WASHER 6*16	螺絲 6*16	1	
		93500-04020-0G	0	SCREW PAN 4*20	螺絲 4*20	3	
		93500-KHC4-90A	0	SCREW PAN 5*10	螺絲 5*10	2	
		94050-06080	0	NUT FLANGE 6MM	螺帽 6MM	7	
		94050-08080	0	NUT FLANGE 8MM	螺帽 8MM	1	
		95701-KHC5-E000-IT	3	BOLT TORQUE 8*25	螺絲 8*25	2	

F 20 Frame Body

車體

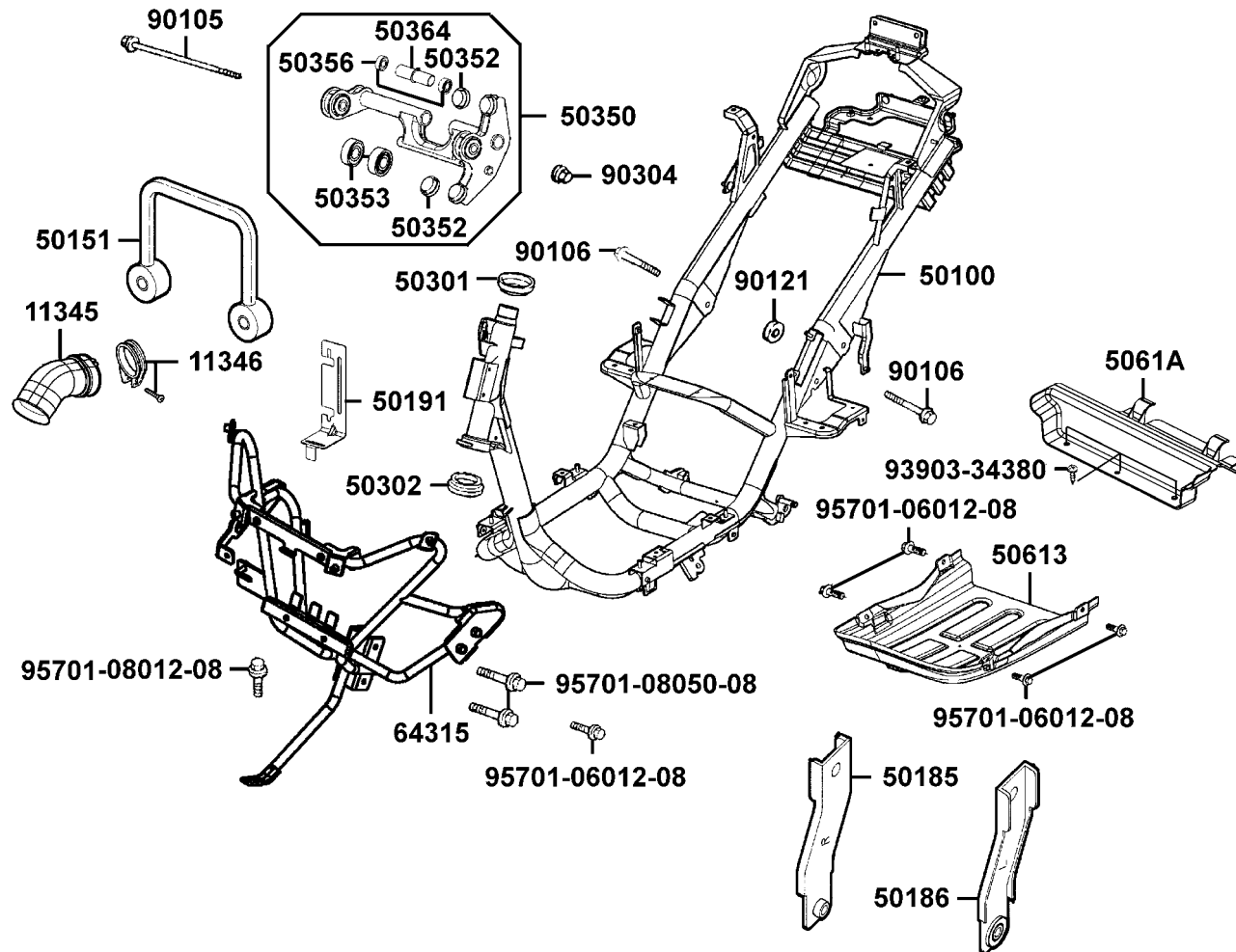

販賣記號 Sales mark	項目 Ref no	零件號碼 Part no	版數 Ver	英文名稱 Description	中文名稱 Chinese	需要用量 Regd no	參考價 Ref Price
		11345-KKC4-9000	0	DUCT L COVER	冷卻導管	1	
		11346-GY6-9010	0	BAND L COVER DUCT	導管束帶	1	
		50100-KKC4-EZ0	2	BODY COMP FRAME	車體	1	
		50151-KKC4-9000	0	HOOK CARRIER	後架座	1	
		50185-KKC4-9000	0	STAY R BODY COVER	車體右邊蓋支柱	1	
		50186-KKC4-9000	0	STAY L BODY COVER	車體左邊蓋支柱	1	
		50191-KKC4-9000	0	STAY ALARM SYSTEM	警示器支架	1	
		50301-KN7-6710	2	RACE UP STRG BALL	上珠碗	1	
		50302-268-0110	0	RACE (STRG BOT) BALL	下珠碗	1	
		50350-KKC4-E000	0	ENG HANGER COMP	引擎吊架	1	
		50352-GY6-9000	0	RUBBER STOPPER	引擎吊架止滑橡皮	2	
		50353-KN7-9010	0	BUSH A ENG HANGER	引擎吊架襯套 A	2	
		50356-KHE7-E000	0	BUSH SWING LOCK	引擎吊架橡皮襯套	2	
		50364-KKC4-E000	0	COLLAR ENG HANGER	引擎吊架套筒	1	
		50613-KKC4-900	1	COVER UNDER	底蓋	1	
		5061A-KKC3-900	1	DEFECTION UNDER	底蓋延伸板	1	
		64315-KKC4-9000	1	STAY FR COVER	前蓋支架	1	
		90105-KN7-6700	1	BOLT FLANGE 10*235.5	螺絲 10*235.5	1	
		90106-KHE7-E000	0	BOLT FLANGE 12*59	螺絲 12*59	2	
		90121-KHE7-E000	0	COLLAR DISTANCE	套筒	1	

F 20 Frame Body

車體

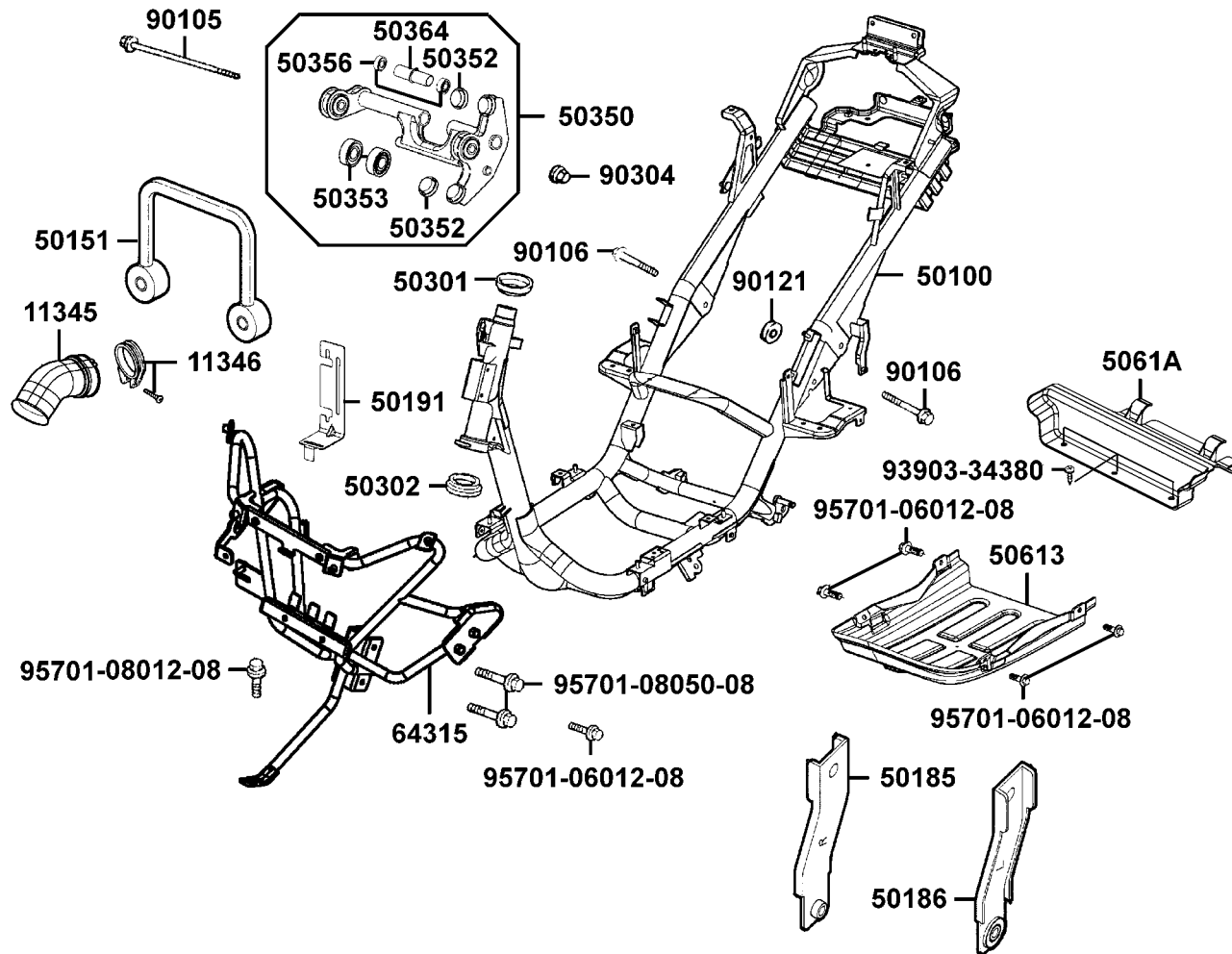

F20

販賣記號 Sales mark	項目 Ref no	零件號碼 Part no	版數 Ver	英文名稱 Description	中文名稱 Chinese	需要用量 Regd no	參考價 Ref Price
		90304-GE8-0040	0	NUT U 10MM	螺帽 10MM	1	
		93903-34380	0	SCREW TAPPING 4*12	螺釘 4*12	3	
		95701-06012-08	0	BOLT FLANGE 6*12	螺絲 6*12	5	
		95701-08012-08	0	BOLT FLANGE 8*12	螺絲 8*12	1	
		95701-08050-08	0	BOLT FLANGE 8*50	螺絲 8*50	2	

F 21 Radiator

水箱

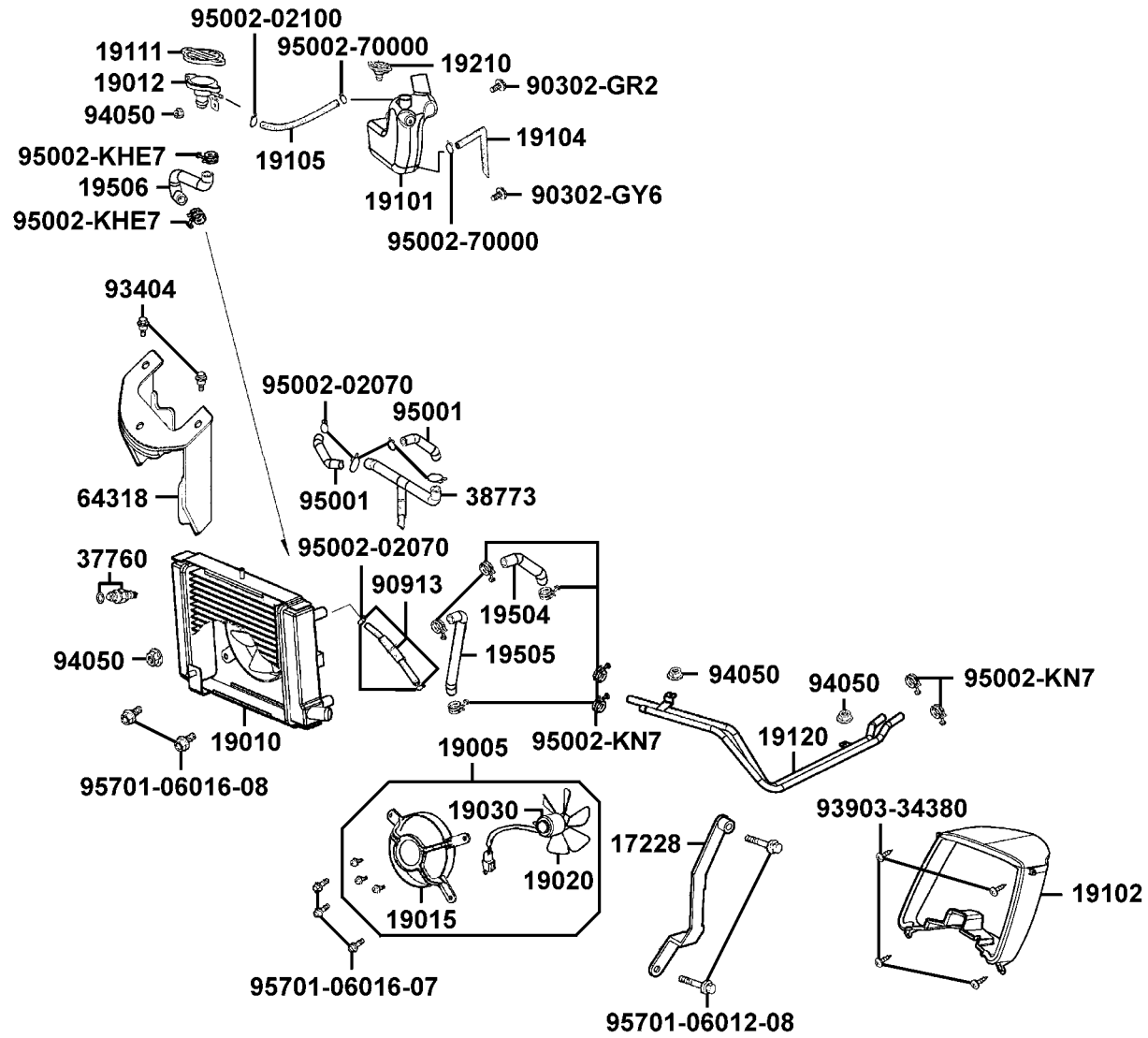

販賣記號 Sales mark	項目 Ref no	零件號碼 Part no	版數 Ver	英文名稱 Description	中文名稱 Chinese	需要用量 Regd no	參考價 Ref Price
		17228-KKC4-9000	0	STAY A/C	空氣濾清器支架	1	
		19005-KKC4-9000	0	SHROUD ASSY	冷卻風扇組	1	
		19010-KKC4-900	1	RADIATOR COMP	水箱	1	
		19012-KHD8-9000	4	UNIT RADIATOR	減壓蓋	1	
		19015-KKC4-9000	0	SHROUD COMP	風扇覆環	1	
		19020-KED9-900	0	FAN COOLING	風扇	1	
		19030-KHD8-9000	0	MOTOR ASSY FAN	風扇馬達	1	
		19101-KKC4-9000	0	TANK RESERVE	預備水箱	1	
		19102-KKC4-9000	0	DUCT COOLING AIR	入風口	1	
		19104-KKC4-9000	0	HOSE ASSY DRAIN	溢流管	1	
		19105-KKC4-9000	0	HOSE ASSY RESERVE-COOLER	水管	1	
		19111-KED9-900	1	CAP COMP	水箱蓋	1	
		19120-KKC4-900	2	PIPE COMP WATER	水管	1	
		19210-KKC4-9000	0	CAP RESERVE TANK	預備水箱蓋	1	
		19504-KKC4-9000	0	HOSE WATER D RADIATOR-PIPE	水管 D	1	
		19505-KKC4-9000	0	HOSE WATER F PIPE-RADIATOR	水管 F	1	
		19506-KKC4-900	1	HOSE WATER G RADIATOR-UNIT	水管 G	1	
		37760-KHD8-9000	0	SW ASSY THERMO	調溫開關	1	
		38773-PB9-0000	0	JOINT 3 WAY 3.5	三向管接頭	1	
		64318-KKC4-9000	0	STAY METER	儀錶支架	1	

F 21 Radiator

水箱

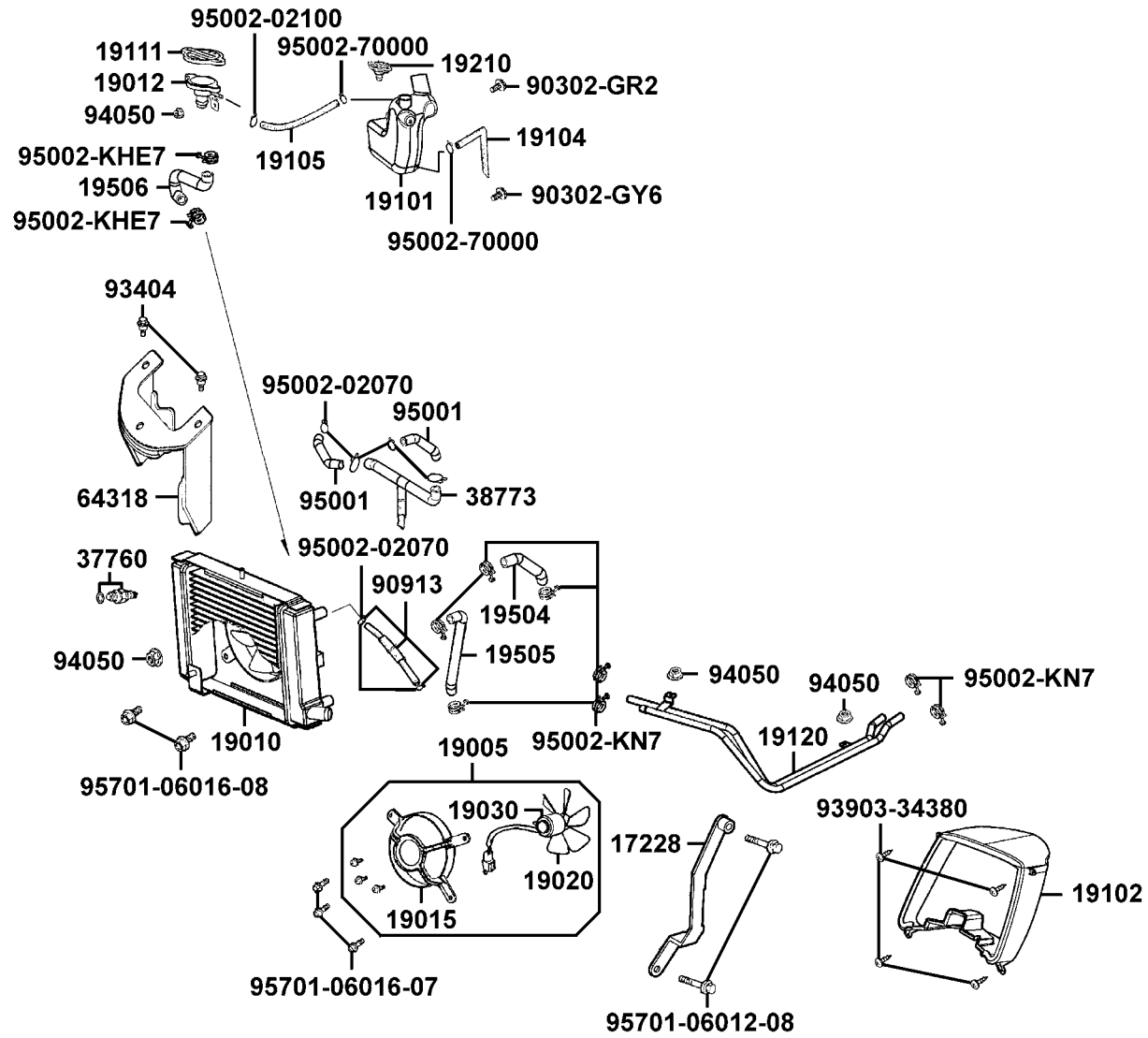

F21

販賣記號 Sales mark	項目 Ref no	零件號碼 Part no	版數 Ver	英文名稱 Description	中文名稱 Chinese	需要用量 Regd no	參考價 Ref Price
		90302-GR2-0000	1	BOLT WASH 5*16	螺絲 5*16	1	
		90302-GY6-9010	0	BOLT WASH 5*12	螺絲 5*12	1	
		90913-KKC4-9000	0	TUBE ASSY WATER PUMP TO RAD	水管組	1	
		93404-06016-07	0	BOLT WASHER 6*16	螺絲 6*16	2	
		93903-34380	0	SCREW TAPPING 4*12	螺釘 4*12	4	
		94050-06080	0	NUT FLANGE 6MM	螺帽 6MM	4	
		95001-35225-40	0	TUBE FUEL 3.5*225	通氣管 3.5*225	2	
		95002-02070	0	CLAMP D6.8 TUBE	管夾	6	
		95002-02100	0	CLIP B10 TUBE	管夾	1	
		95002-70000	0	CLIP C11 TUBE	管夾	2	
		95002-KHE7-9000	0	CLIP WATER HOSE	水管夾	2	
		95002-KN7-9100	1	CLIP TUBE	水管夾	8	
		95701-06012-08	0	BOLT FLANGE 6*12	螺絲 6*12	2	
		95701-06016-07	0	BOLT FLANGE 6*16	螺絲 6*16	3	
		95701-06016-08	0	BOLT FLANGE 6*16	螺絲 6*16	2	

F 22 Separated Parts Of Fr Fork

前
叉
附
件

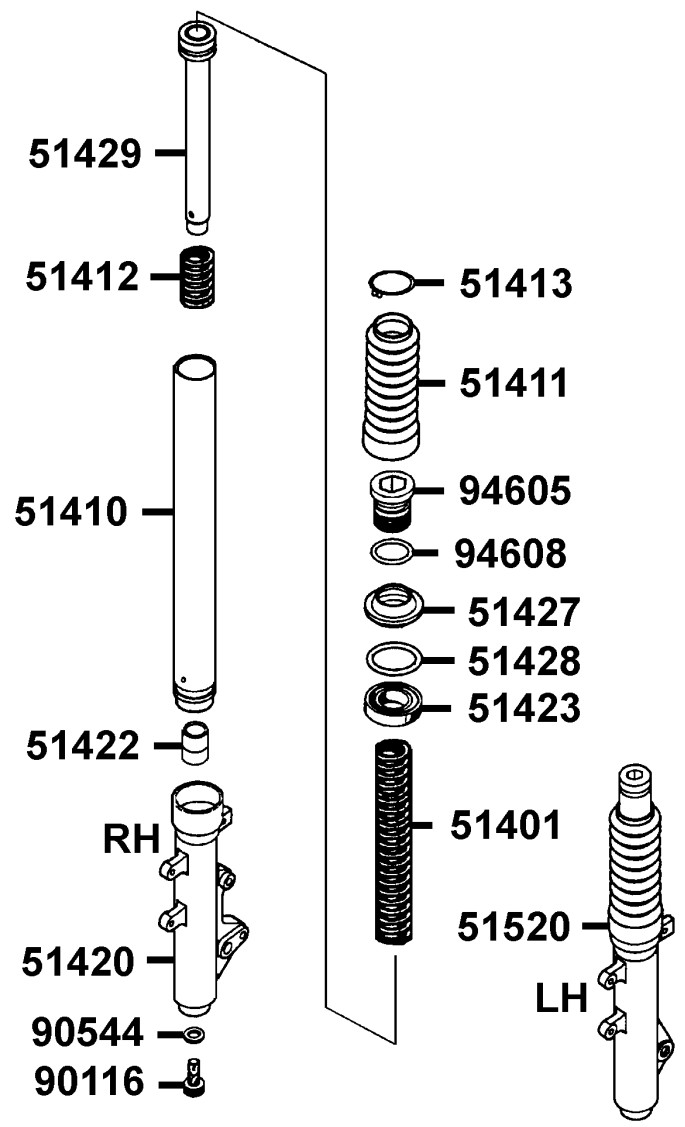

販賣記號 Sales mark	項目 Ref no	零件號碼 Part no	版數 Ver	英文名稱 Description	中文名稱 Chinese	需要用量 Regd no	參考價 Ref Price
		51401-KHD8-9000	0	SPRING	彈簧	2	
		51410-KHD8-9000	0	FORK PIPE COMP	前避震器管	2	
		51411-KHD8-9000	0	BOOT	護套	2	
		51412-KHD8-9000	0	REBOUND SPRING	回位彈簧	2	
		51413-KHD8-9000	0	BOOT BAND	護套夾	2	
		51420-KKC4-9000	0	BOTTOM CASE R	右前避震器底管	1	
		51422-KKC4-900	0	OIL LOCK PIECE	止油接頭	2	
		51423-KAK-9000	0	OIL SEAL	前避震器油封	2	
		51427-KAK-9000	0	DUST SEAL	防塵封	2	
		51428-KAK-9000	0	RING OIL SEAL STOPPER	油封止位環	2	
		51429-KHD8-9000	0	PIPE SEAT COMP	避震管座	2	
		51520-KKC4-9000	0	BOTTOM CASE L	左前避震器底管	1	
		90116-KHD8-9000	0	BOLT	螺絲	2	
		90544-KEC8-9000	0	PACKING	墊片	2	
		94605-KHD8-9000	0	FORK BOLT	螺絲	2	
		94608-30000	0	O-RING 23*24	O環 23*24	2	

F 23 Air Cleaner Two

二次空氣濾清器

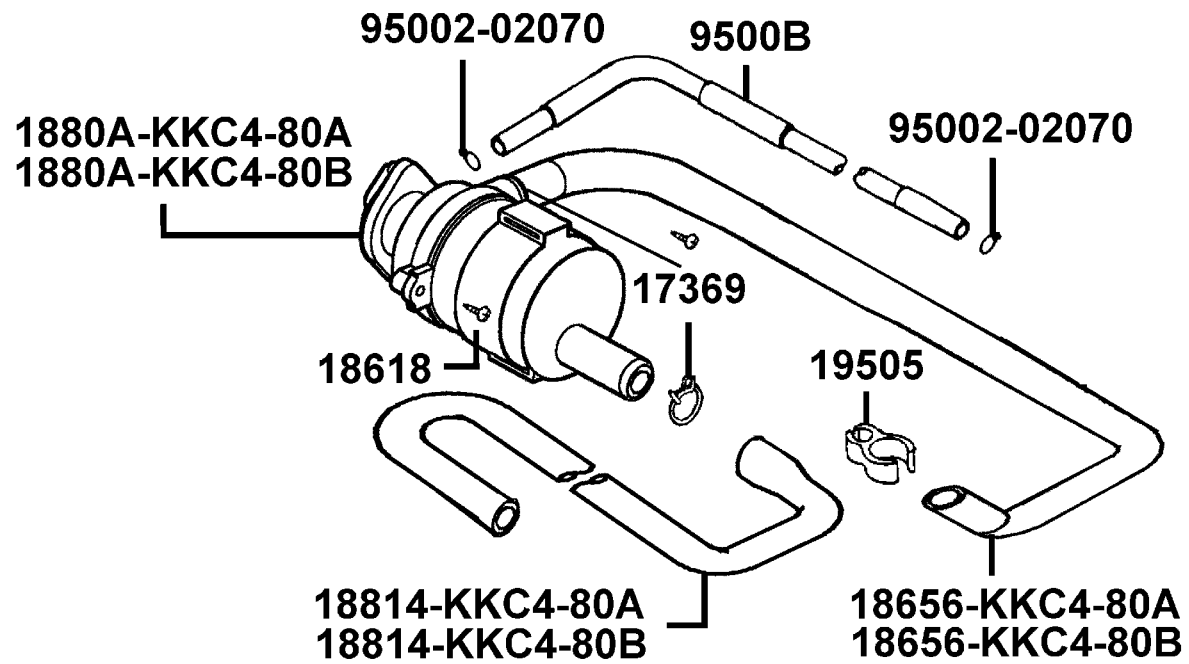

販賣記號 Sales mark	項目 Ref no	零件號碼 Part no	版數 Ver	英文名稱 Description	中文名稱 Chinese	需要用量 Regd no	參考價 Ref Price
		17369-KB4-6700	1	CLIP BREATHER TUBE	通氣管夾	2	
		18618-LLF5-900	0	RUBBER AI CLEANER MOUNT	橡皮	1	
		18656-KKC4-80A	0	DUCT AICV REED VALVE	通氣管	1	
		18656-KKC4-80B	0	DUCT AICV REED VALVE	通氣管	1	
		1880A-KKC4-80A	2	AI/C AICV ASSY	空氣噴射控制閥	1	
		1880A-KKC4-80B	2	AI/C AICV ASSY	空氣噴射控制閥	1	
		18814-KKC4-80A	0	DUCT AIR AICV	二次空氣濾清器導管	1	
		18814-KKC4-80B	0	DUCT AIR AICV	二次空氣濾清器導管	1	
		19505-GY6-9400	2	CLAMP A W/H	水管夾	1	
		95002-02070	0	CLIP B7 TUBE	管夾	2	
		9500B-KE2-7000	0	TUBE ASSY AICV INLET PIPE	通氣管	1	

F 24 Caution Label

注意標籤

● Be sure to wear a safety helmet when riding.
 ● Do not exceed the speed specified by law when riding.
 ● The ambient weather temperature is very high after riding. Be sure to park the motorcycle in a place not easily touched by people.
 ● For riding safety and good performance, do not violate the law to modify the motorcycle.
 ● Please read the Owner's Manual carefully to ensure riding safety.

● Make sure to perform the periodic maintenance and provide inspection.

Provide inspection items

Brake Performance, tires, engine oil level, lights, horn, and instrument panel

KWANG YANG MOTOR CO., LTD.

© Please read the Owner's Manual carefully to ensure riding safety.

87560

CAUTIONS

Tire Size	:Front 120/70-12	Rear 140/70-12
(One Rider)	:Front 1.75kgf/cm ²	Rear 2.25kgf/cm ²
(Two Rider)	:Front 2.00kgf/cm ²	Rear 2.50kgf/cm ²
Load Capacity	:Shield 1.5kg Clip away carrier 3kg (As per KYMCO standard specification)	
(Note: The tire pressure must not overpass 2.80kgf/cm ²)		

● Check the motor oil level with the dipstick after refilling motor oil.

KYC-089

87505

USE UNLEADED GASOLINE ONLY

87501

CAUTION

Mobile phone charge only, Use other appliance may cause damage.

KKC2-E000

87541-KKC2

CAUTIONS

Every 5000 km run should exchange the filter.

KC-01

87512

CAUTIONS

Never put any article between the rear side cover and the engine to avoid interference of riding.

GM9-300

87542

CAUTIONS

Before starting the engine, the side stand shall be kicked up to secure safety.

87541-GR1

F24

販賣記號 Sales mark	項目 Ref no	零件號碼 Part no	版數 Ver	英文名稱 Description	中文名稱 Chinese	需要用量 Regd no	參考價 Ref Price
		87501-KDR-E00	0	CAUTION USE GAS ONLY	貼紙	1	
		87505-KHE7-E00	0	LABEL TIRE	貼紙	1	
		87512-KBE-E00	0	CAUTION FILTER	貼紙	1	
**		87541-GR1-E00	1	CAUTION SIDE STAND	貼紙	1	
		87541-KKC2-E00	0	CAUTION MOBILE PHONE	貼紙	1	
**		87542-GR1-E00	0	MARK MAINT CAUTION	貼紙	1	
		87560-GY6-E00	3	MARK DRIVE CAUTION	貼紙	1	

標
徽
●
貼
紙



86202



86212

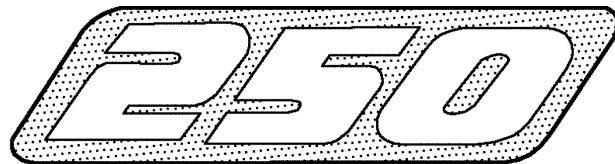

87140



87311



86030

F25

販賣記號 Sales mark	項目 Ref no	零件號碼 Part no	版數 Ver	英文名稱 Description	中文名稱 Chinese	需要用量 Regd no	參考價 Ref Price
**		86030-KKC4-900	0	EMB HANDLE COVER RR	手柄後蓋標誌	1	
		86202-KKC4-900	0	EMB BODY COVER	車體邊蓋標誌	2	
		86212-KKC4-900	0	EMB B BODY COVER	車體邊蓋標誌 B	2	
		87140-KHE7-E00	0	EMB B BODY COVER	車體邊蓋標誌 B	2	
		87311-KKD6-E00	0	STRIPE MARK EURO 2	EURO 2 標誌	1	



零件號碼索引
PARTS NO. INDEX

零件號碼索引

PART NO. INDEX

零件號碼 PART NO.	版數 VERSION	頁次 PAGE	零件號碼 PART NO.	版數 VERSION	頁次 PAGE	零件號碼 PART NO.	版數 VERSION	頁次 PAGE
0			1190-B30-2002	0	P-43	1402-939-2100	0	P-43
			1190-B63-2100	0	P-43	14100-KHE7-220	0	P-19
0137-261-36G5	0	P-43				14401-KHE7-9000-M1	0	P-25
0301-261-36G5	0	P-43	12000			14401-KHE7-9000-M2	0	P-25
						14431-KHE7-9000	0	P-19
10000			1201-830-2300	1	P-43	14450-KBE-9000	0	P-19
			12100-KHE7-9000	3	P-25	14461-KHE7-9000	0	P-19
			12191-KHE7-900	3	P-25	14510-KHE7-9000	0	P-25
1028-054-7000	0	P-43	12200-KHE7-900	0	P-19	14520-GY6-90A	1	P-25
1030-892-2101	0	P-43	12205-KE8-3010	0	P-19	14523-GY6-9000	0	P-25
1052-862-2100	0	P-43	12209-GB4-6820-M1	0	P-19	14531-KHE7-9000	0	P-25
1090-872-2000	0	P-43	1221A-KHE7-9000	0	P-19	14610-KHE7-9000	0	P-25
			12251-KHE7-9010	0	P-19	14711-KHE7-9000	0	P-19
			1229-805-7000	0	P-43	14721-KHE7-9000	1	P-19
11000			1230-850-2000	0	P-43	14751-KHE7-9000	0	P-19
			1230-851-2001	0	P-43	14761-KHE7-9000	0	P-19
11100-KHE7-305	5	P-15	1230-856-7001	0	P-43	14771-GB4-6800	2	P-19
11102-187-0030	3	P-15	12310-KHE7-E000	0	P-19	14775-MA6-0000	0	P-19
11102-187-0030	3	P-99	12361-GY6-9010	0	P-29	14781-MA6-0000-M1	0	P-19
11103-KHE7-9000	0	P-15	12391-KHE7-9000	0	P-19			
11192-KHE7-9000	0	P-15	1290-996-2000	0	P-43	15000		
11200-KKC4-3050	1	P-15	1290-A07-2000	0	P-43			
11207-KKC4-9000	3	P-91				15100-KBE-9000	0	P-37
11211-KKC4-9000	0	P-91				15133-KM1-0010	0	P-37
1122A-KKC4-9000	0	P-41	13000			15141-KJ9-0040	0	P-37
11330-KHE7-900	5	P-29				15421-107-0000	1	P-29
11341-KHE7-9000	0	P-15	13000-KHE7-9000	4	P-25	15426-GE1-9200	0	P-29
11345-KKC4-9000	0	P-113	13011-KHE7-9000	0	P-25	15441-149-0010	0	P-25
11346-GY6-9010	0	P-113	13101-KHE7-9000	3	P-25	15447-149-0010	0	P-25
1134A-KHE7-900	3	P-15	13111-KHE7-9000	1	P-25	1565A-KBE-9000	0	P-29
11383-KDU-9000	0	P-15				15711-KHE7-9000	0	P-37
11384-KHE7-9000	1	P-29						
11394-KHE7-9000	1	P-29	14000					
11395-KHE7-9000	0	P-15						

零 件 號 碼 索 引

PART NO. INDEX

零 件 號 碼 PART NO.	版 數 VERSION	頁 次 PAGE	零 件 號 碼 PART NO.	版 數 VERSION	頁 次 PAGE	零 件 號 碼 PART NO.	版 數 VERSION	頁 次 PAGE
16000			17682-KKC4-9000	0	P-81	19010-KKC4-900	1	P-117
			17683-KKC4-9000	0	P-81	19012-KHD8-9000	4	P-117
1610K-KKC4-E000	2	P-43	17689-KBE-9000	1	P-81	19015-KKC4-9000	0	P-117
16145-MZ2-7800	0	P-43	17910-KKC4-9000	0	P-55	19020-KED9-900	0	P-117
1614-834-2100	0	P-43	17911-KKC4-9000	0	P-55	19030-KHD8-9000	0	P-117
16199-GY6-9000	0	P-43				19101-KKC4-9000	0	P-117
16700-KHE7-900	5	P-81				19102-KKC4-9000	0	P-117
16911-KKC4-9000	0	P-81	18000			19104-KKC4-9000	0	P-117
16912-KKC4-9000	0	P-81				19105-KKC4-9000	0	P-117
1691A-KEC2-E000	0	P-81	18291-166-0040	0	P-95	19111-KED9-900	1	P-117
16978-ZB9-0050	0	P-45	18293-KCE-9000	0	P-95	19120-KKC4-900	2	P-117
			18294-KBE-9000	0	P-95	19210-KKC4-9000	0	P-117
			18295-KCE-9000	0	P-95	19215-KHE7-9000	0	P-29
17000			18305-KHD8-9000	0	P-95	19217-657-0240	0	P-29
			18306-KHE7-9000	0	P-95	19221-KHE7-9000	0	P-29
17110-KHE7-900	0	P-19	1830A-KHE7-EZ0	1	P-95	19229-KHE7-9000	0	P-29
17214-KKC3-9000	0	P-91	18318-KHE7-E000	0	P-95	19231-KJ9-0110	0	P-29
17215-KGBG-9000	0	P-91	18325-KHE7-9000	1	P-95	19300-KE1-0030-M1	1	P-21
1721A-KKC3-9000	1	P-91	18601-MJ1-7900	1	P-19	19310-KHE7-9000	0	P-21
17228-KKC4-9000	0	P-117	18612-GY6-9400	0	P-21	19315-KHE7-9000	0	P-21
17231-KKC3-900	1	P-91	18618-LLF5-900	0	P-123	19411-KCB-9000	0	P-81
1723A-KKC4-E00	2	P-91	18645-GY6-9400	0	P-21	19501-KHE7-9000	0	P-29
17254-KCA-P000	0	P-91	18646-GY6-9400	0	P-21	19502-KHE7-9000	0	P-29
17369-KB4-6700	1	P-123	18647-KHE7-900	0	P-21	19503-KHE7-900	1	P-21
17370-419-7010	0	P-91	18656-KKC4-80A	0	P-123	19504-KKC4-9000	0	P-117
17371-174-6700	0	P-91	18656-KKC4-80B	0	P-123	19505-GY6-9400	2	P-123
17500-KKC4-9000	1	P-81	1880A-KKC4-80A	2	P-123	19505-KKC4-9000	0	P-117
17502-KKC4-9000	0	P-81	1880A-KKC4-80B	2	P-123	19506-KKC4-900	1	P-117
17510-KKC4-9000	0	P-81	18814-KKC4-80A	0	P-123			
17520-KKC4-9000	0	P-109	18814-KKC4-80B	0	P-123			
17550-KHC4-9000	0	P-81				21000		
17620-KHC5-E000-IT	0	P-109						
17620-KHC5-E000-IT-M2	1	P-109	19000			21200-KHE7-3050	0	P-41
17623-KHC4-9000	6	P-109				21395-KHE7-9000	0	P-41
17623-KHC4-9000-M2	1	P-109	19005-KKC4-9000	0	P-117			

零件號碼索引

PART NO. INDEX

零件號碼 PART NO.	版數 VERSION	頁次 PAGE	零件號碼 PART NO.	版數 VERSION	頁次 PAGE	零件號碼 PART NO.	版數 VERSION	頁次 PAGE
22000			28000			32100-KKC4-E10	4	P-109
22101-KHE7-9000	0	P-33	28101-KHE7-9000	0	P-37	32101-KHE7-E000	0	P-37
22102-KHE7-900	1	P-33	28102-KHE7-9000	0	P-37	32410-KKC4-900	1	P-37
22105-KHE7-900	1	P-33	28110-KHE7-9000	2	P-37	32411-KKC4-9000	0	P-85
22110-KHE7-900	2	P-33	28120-KHE7-E000	0	P-37	32412-KKC4-900	2	P-85
22112-KHE7-900	1	P-33				33000		
22121-KHE7-9000-M1	0	P-33				33100-KKC4-E000	3	P-51
22131-KHE7-9000	0	P-33	29000			33120-KKC4-E000	1	P-51
22132-KHE7-9000	2	P-33				33130-KKC4-E000	0	P-51
22300-KHE7-9000	0	P-33	290-A28-2000	0	P-45	33400-KKC4-E000	0	P-101
22350-KHE7-9000	0	P-33				33402-KKC4-E000	0	P-101
22361-KHE7-9000	0	P-33				33403-KKC4-E000	0	P-101
22401-KHE7-9000	0	P-33	30000			33407-KKC4-E000	0	P-101
22530-KHE7-9000	0	P-33				33450-KKC4-E000	0	P-101
22804-GB2-0010	0	P-33	30400-KHE7-900	2	P-109	33452-KKC4-E000	0	P-101
			3051A-KKC4-9000	0	P-109	33453-KKC4-E000	0	P-101
			30700-KFC8-E000-M8	1	P-109	33457-KKC4-E000	0	P-101
23000						33600-KKC4-E000	2	P-101
2301A-KHE7-900	5	P-33	31000			33602-KKC4-E000	0	P-101
23100-KHE7-9000	0	P-33				33603-KKC4-E000	0	P-101
23200-KHE7-900	4	P-33	31110-KHE7-9000-M1	0	P-37	33606-KKC4-E000	0	P-101
23220-KHE7-9000	3	P-33	31120-KKC4-90A	1	P-37	33607-KKD7-E000	0	P-101
23225-KHE7-9000	0	P-33	31210-KHE7-9000-M1	1	P-37	33650-KKC4-E000	1	P-101
23226-GC8-0040	0	P-33	31500-KHE7-9000-M1	0	P-85	33652-KKC4-E000	0	P-101
23233-KHE7-9000	0	P-35	31500-KHE7-90B	2	P-85	33653-KKC4-E000	0	P-101
23237-KHE7-9000	0	P-35	31600-KM1-009	9	P-109	33656-KKC4-E000	0	P-101
23238-KHE7-9000	0	P-35	31601-KKC4-900	3	P-109	33700-KKC4-E000	0	P-105
23411-KHE7-900	3	P-41	31602-KKC4-9000	0	P-109	33702-KKC4-E000	0	P-105
23420-KHE7-910	0	P-41				33705-KKC4-E000	0	P-105
23431-KHE7-9000	0	P-41				33706-KHB4-E10	0	P-105
23432-KHE7-910	0	P-41	32000			33709-KAB-0030	0	P-105
						33722-KHB4-E000	0	P-105

零件號碼索引

PART NO. INDEX

零件號碼 PART NO.	版數 VERSION	頁次 PAGE	零件號碼 PART NO.	版數 VERSION	頁次 PAGE	零件號碼 PART NO.	版數 VERSION	頁次 PAGE
33725-KHB4-E000	0	P-105	37000			40000		
33726-KHB4-E000	0	P-105						
33741-GY6-C300	1	P-63	37200-KKC4-900	3	P-53	4000-183-0000	0	P-45
33741-KBE-9000	0	P-105	37203-KKC4-900	0	P-53			
33900-KBF-9000	0	P-87	37204-KKC4-900	0	P-53			
			37710-KGBG-E000	0	P-45	41000		
34000			37720-KGB5-9000	0	P-21			
			37720-KGBG-E000	0	P-45	4115-803-1100	0	P-45
			37720-KGBG-E000	0	P-111	4115-804-1100	0	P-45
34901-KED9-900	0	P-51	37750-PC1-0050	0	P-21			
34903-KCP-9000	0	P-51	37760-KGBG-E100	0	P-111			
34903-KCP-9000	0	P-105	37760-KHD8-9000	0	P-117	42000		
34905-KCP-9000	0	P-101	37801-GA7-7000	1	P-81			
34906-KCP-9000	0	P-105	37802-GA7-7000	2	P-81	42311-KHE7-E000	0	P-75
34909-KBE-9000	0	P-53	3780A-KKC4-9000	1	P-81	42312-KHE7-E000	0	P-75
34909-KBF-9000	0	P-87				42601-KHE7-E00	1	P-75
			38000			42710-KKC4-900	1	P-75
35000						42753-KBN-9020-M2	0	P-75
						42753-KCX-9000	1	P-71
			3800A-KKC4-900	1	P-111			
35101-KHC4-3050	5	P-109	38110-KKC3-90A	1	P-111			
35101-KHC4-3050-M2	0	P-109	38110-KKC3-90B	1	P-111	43000		
35102-KHC4-9000	2	P-109	38300-KCE-9000	1	P-111			
35102-KHC4-9000-M2	0	P-109	38500-KHD8-9000	0	P-85	43100-KKC4-900	0	P-75
3515A-KKC4-9000	1	P-55	38500-KHD8-9000-M1	0	P-85	43105-KKC4-9000	0	P-75
3520A-KBE-9000	2	P-55	38773-PB9-0000	0	P-117	43107-KKC4-9000	0	P-75
35340-KBN-9000	0	P-59				43108-KKC4-9000	0	P-75
35350-KBN-9000	0	P-59				43109-KKC4-9000	0	P-75
35360-KBF-9000	1	P-87	39000			43109-MA3-0070	0	P-71
35370-KEC8-E000	1	P-109				43115-KKC4-9000	0	P-75
35400-KHE7-900	1	P-109	39100-KHD8-9000	0	P-111	43126-KKC4-9000	3	P-59
35850-KHD8-9000	1	P-109	3930A-KKC4-900	2	P-111	43127-KKC4-9000	0	P-59
35850-KHD8-9000-M1	0	P-109				43156-KKC4-9000	1	P-59
						43209-KKC4-9000	0	P-75
						43209-MA3-0070	0	P-71

零 件 號 碼 索 引

PART NO. INDEX

零 件 號 碼 PART NO.	版 數 VERSION	頁 次 PAGE	零 件 號 碼 PART NO.	版 數 VERSION	頁 次 PAGE	零 件 號 碼 PART NO.	版 數 VERSION	頁 次 PAGE
43351-KHE7-E00	1	P-75	45203-KKC4-9000	0	P-75	50352-GY6-9000	0	P-113
43352-568-0030	3	P-71	45207-KKC4-9000	0	P-71	50353-KN7-9010	0	P-113
43352-568-0030	3	P-75	45208-KKC4-9000	0	P-71	50356-KHE7-E000	0	P-113
43353-461-7710-M1	0	P-71	45209-KFA6-9000	0	P-73	50364-KKC4-E000	0	P-113
43353-461-7710-M1	0	P-75	45210-KKC4-9000	0	P-73	50502-GY6-9010	0	P-97
43416-KKC4-900	0	P-105	45351-KHE7-E000	0	P-73	50504-KKC4-900	2	P-15
43530-KKC4-3050	0	P-59	45513-GW0-9120-M1	0	P-59	50505-KHE7-E000	0	P-97
			45513-KCX-M000-US	1	P-59	50506-KHE7-E000	0	P-97
			45517-KAF-9100	0	P-59	5050A-KKC4-9000	1	P-97
44000			45530-KFC8-E000-IT	2	P-59	50530-KKC4-900	1	P-97
			45531-GR1-9510	0	P-73	50550-KEB7-E000	1	P-97
44301-KCX-900	1	P-71	45531-GR1-9510	0	P-75	50613-KKC4-900	1	P-113
44311-KBE-9000	0	P-71				5061A-KKC3-900	1	P-113
44620-KHD8-9000	0	P-71						
44650-KHD8-30A	3	P-71	46000					
44710-KKC4-900	2	P-71				51000		
44800-KFA5-9000	1	P-71	46514-KBF-9000	0	P-87			
44830-KKC4-9000	2	P-53				51400-KKC4-900	2	P-69
44831-KKC4-9000	0	P-53				51401-KHD8-9000	0	P-121
			50000			51410-KHD8-9000	0	P-121
45000						51411-KHD8-9000	0	P-121
			50100-KKC4-EZ0	2	P-113	51412-KHD8-9000	0	P-121
			50139-KKC4-9000	0	P-81	51413-KHD8-9000	0	P-121
45103-MR7-0070	0	P-71	50151-KKC4-9000	0	P-113	51420-KKC4-9000	0	P-121
45105-KKC4-305	0	P-71	50185-KKC4-9000	0	P-113	51422-KKC4-900	0	P-121
45107-KKC4-9000	0	P-71	50186-KKC4-9000	0	P-113	51423-KAK-9000	0	P-121
45109-KFA6-9000	0	P-71	50191-KKC4-9000	0	P-113	51427-KAK-9000	0	P-121
45111-KKC4-9000	0	P-75	50197-KKC4-9000	0	P-81	51428-KAK-9000	0	P-121
45115-KKC4-9000	0	P-71	50301-KN7-6710	2	P-113	51429-KHD8-9000	0	P-121
45126-KKC4-9000	0	P-59	50302-268-0110	0	P-113	5150A-KKC4-900	3	P-69
45127-KKC4-9000	0	P-59	50306-196-0010	0	P-69	51520-KKC4-9000	0	P-121
45128-KKC4-9000	0	P-59	50326-KKC4-900	0	P-85			
45156-KCE-9000	1	P-69	50328-KBN-2000	0	P-85			
45200-KKC4-900	1	P-71	5032A-KKC4-9000	0	P-85	52000		
45203-KKC4-9000	0	P-71	50350-KKC4-E000	0	P-113			

零件號碼索引

PART NO. INDEX

零件號碼 PART NO.	版數 VERSION	頁次 PAGE	零件號碼 PART NO.	版數 VERSION	頁次 PAGE	零件號碼 PART NO.	版數 VERSION	頁次 PAGE
52000-KKC4-900	0	P-99	64000			80000		
52400-KKC4-900	3	P-99						
53000			64220-KKC4-9000	0	P-63	80100-KKC4-900	3	P-105
			64221-KKC4-9000	0	P-63	80101-KKC4-900	1	P-105
			64222-KKC4-9000	3	P-63	80102-KKC4-900	2	P-105
			64301-KKC4-900	0	P-63	80105-KKC4-9000	1	P-105
53100-KKC4-9000	0	P-55	64302-KKC4-900	0	P-63	80106-KKC4-9000	0	P-105
53105-KFC8-9000	2	P-55	64305-KKC4-900	1	P-63	80151-KKC4-900	0	P-87
53106-KFC8-9000	0	P-55	64306-KKC4-900	2	P-63			
53125-GN5-9010	0	P-55	64309-KKC4-9000	0	P-63			
53140-KKC4-900	0	P-55	64310-KKC4-900	0	P-63	81000		
53166-KGB5-900	0	P-55	64311-KKC4-900	3	P-63			
53175-KFA5-E10	0	P-59	64312-KKC4-900	3	P-63	81131-KKC4-900	0	P-65
53178-KFC8-E10	0	P-59	64315-KKC4-9000	1	P-113	81132-KEB7-900	0	P-65
53200-KKC2-9000	1	P-69	64317-KKC4-9000	0	P-63	81136-KKC4-900	0	P-65
53204-KKC4-900	2	P-63	64318-KKC4-9000	0	P-117	81137-KKC4-900	0	P-65
53205-KKC4-900	0	P-55	64320-KKC4-900	0	P-63	81147-KKC4-900	0	P-65
53206-KKC4-900	0	P-55	64321-KKC4-900	2	P-63	81151-KKC4-9000	0	P-87
53207-KKC4-900	0	P-55	64322-KKC4-900	1	P-63	81201-KKC4-900	1	P-87
53208-KKC4-900	0	P-55	64327-KKC4-900	0	P-53	81202-KKC4-900	0	P-87
53209-KKC4-9000	0	P-55	64400-KKC4-900	0	P-63	8120A-KKC4-900	6	P-87
53211-GY6-9400	0	P-69				81255-KKC4-9000	0	P-87
53212-250-0110	0	P-69				81257-KKC4-800	0	P-87
53214-250-0010	0	P-69	77000			81260-KKC4-9000	1	P-87
53214-KKC4-900	0	P-63				81400-KKC4-900	0	P-87
53215-250-0010	0	P-69	77200-KKC4-E10	0	P-79	81500-KKC4-900	0	P-87
53224-KKC4-900	0	P-63	77210-KKC4-900	0	P-79			
			77220-KKC4-910	0	P-79			
			77235-KKC4-9000	0	P-87	83000		
61000			77240-KKC4-9000	1	P-87			
			77300-KKC4-900	3	P-79	83500-KKC4-900	0	P-87
61110-KHD8-900	2	P-69	77305-KKC4-9000	1	P-79	83600-KKC4-900	1	P-87
						8360A-KKC4-9000	0	P-91
						83750-KKC4-900	1	P-87
						8376A-KBE-900	3	P-65

零 件 號 碼 索 引

PART NO. INDEX

零 件 號 碼 PART NO.	版 數 VERSION	頁 次 PAGE	零 件 號 碼 PART NO.	版 數 VERSION	頁 次 PAGE	零 件 號 碼 PART NO.	版 數 VERSION	頁 次 PAGE
86000			89000			90110-KEB7-9000	0	P-69
86030-KKC4-900	0	P-127	89010-KKC4-900	0	P-79	90110-KHD8-9000	0	P-95
86102-KKC4-900	1	P-65	89013-KFC8-E000	1	P-79	90111-187-0000	1	P-89
86202-KKC4-900	0	P-127	89020-KKC4-900	0	P-79	90112-KBN-9010	0	P-85
86212-KKC4-900	0	P-127				90112-KBN-9010	0	P-105
			90000			90114-166-0070	1	P-59
87000			90001-GHB-6610	0	P-25	90114-GM4-0110	1	P-91
87140-KHE7-E00	0	P-127	90001-GHB-6610	0	P-37	90116-KHD8-9000	0	P-121
87311-KKD6-E00	0	P-127	90005-KEC8-9000	1	P-25	90121-KHE7-E000	0	P-113
87501-KDR-E00	0	P-125	90012-333-0010	0	P-21	90122-KBE-9000	0	P-73
87505-KHE7-E00	0	P-125	90021-GY6-9000	0	P-95	90131-GW0-9110	0	P-75
87508-KKC4-E00	0	P-65	90031-KBE-9000	0	P-15	90131-KAF-9000	0	P-99
87512-KBE-E00	0	P-125	90032-KBE-9000	0	P-15	90145-MS9-6120-M1	0	P-59
87541-GR1-E00	1	P-125	90033-GY6-9000	0	P-21	90201-KHE7-9000	0	P-35
87541-KKC2-E00	0	P-125	90033-GY6-9410	0	P-21	90201-KR8-7520-M1	0	P-35
87542-GR1-E00	0	P-125	90071-MB0-0010	0	P-37	90201-KR8-7520-M1	0	P-37
87560-GY6-E00	3	P-125	90084-428-0010	0	P-29	90202-187-0010	0	P-35
			9008A-KHE7-9000	0	P-29	90206-001-0010	0	P-21
88000			90105-KBN-9010	0	P-87	90215-GM0-9100	0	P-95
88110-KKC4-900	7	P-55	90105-KEC8-9000	0	P-89	90215-KKC4-900	0	P-89
88114-KKC4-9000	3	P-55	90105-KN5-0010	0	P-89	90301-634-6700	0	P-105
88115-KKC4-9000	0	P-55	90105-KN7-6700	1	P-113	90301-GY6-9010	1	P-95
88116-KKC4-9000	3	P-55	90105-KR3-0010	1	P-73	90302-GR2-0000	1	P-65
88120-KKC4-900	7	P-55	90105-KR3-0010	1	P-75	90302-GR2-0000	1	P-119
88125-KKC4-9000	0	P-57	90106-GN5-9010	0	P-57	90302-GY6-9010	0	P-57
88126-KKC4-9000	3	P-57	90106-KFC2-9000	0	P-57	90302-GY6-9010	0	P-65
88130-KKC4-9000	0	P-57	90106-KFC2-9000	0	P-89	90302-GY6-9010	0	P-119
88135-KKC4-9000	1	P-57	90106-KHE7-E000	0	P-113	90302-GY6-9400	0	P-53
			90106-KKC4-900	0	P-89	90302-GY6-9400	0	P-65
			90108-KKC4-900	0	P-97	90302-GY6-9400	0	P-89
						90302-GY6-9400	0	P-105
						90302-GY6-9400	0	P-105
						90302-KFC2-9000	0	P-57
						90302-KFC2-9000	0	P-107
						90302-SA4-0040	1	P-65
						90302-SA4-0040	1	P-89

零件號碼索引

PART NO. INDEX

零件號碼 PART NO.	版數 VERSION	頁次 PAGE	零件號碼 PART NO.	版數 VERSION	頁次 PAGE	零件號碼 PART NO.	版數 VERSION	頁次 PAGE
90304-438-0000	2	P-21	91002-GA7-70A	0	P-35	93404-KKC2-900	0	P-65
90304-GE8-0040	0	P-57	91003-KHE7-900	0	P-15	93500-03010-1A	0	P-37
90304-GE8-0040	0	P-115	91004-KHE7-900	1	P-35	93500-04008-1H	0	P-45
90305-GK8-0010	0	P-89	91009-KHE7-9000	0	P-41	93500-04010-1H	0	P-45
90305-KW6-9120-M2	0	P-77	91201-KJ9-0040	0	P-31	93500-04012-0H	0	P-89
90306-KF0-901	0	P-73	91202-KHE7-9000	0	P-15	93500-04012-1H	0	P-45
90381-GZ5-0010	0	P-89	91202-KKC4-900	0	P-15	93500-04020-0G	0	P-111
90401-KJ9-0010	0	P-35	91211-KHE7-9000	0	P-35	93500-05016-0H	0	P-23
90401-KJ9-0010	0	P-37	91255-KHE7-9000	0	P-41	93500-05016-0H	0	P-39
90423-KJ9-0010	0	P-29	91301-KHE7-9000	0	P-21	93500-05016-1B	0	P-57
90441-GY6-9410	0	P-35	91302-001-0210	0	P-31	93500-05025-1B	0	P-57
90465-MC4-0010	0	P-21	91302-200-0010	0	P-21	93500-05032-1B	0	P-57
90474-333-0010	0	P-15	91302-KHE7-9000	0	P-31	93500-05045-1B	0	P-57
90478-700-0010	0	P-21	91303-377-0010	0	P-31	93500-KHC4-90A	0	P-111
90478-700-0010	0	P-29	91306-105-6910	0	P-25	93600-04012-1G	0	P-59
9052A-GY6-9500	0	P-15	91307-035-0010	0	P-31	93700-05018-0H	0	P-53
90544-KEC8-9000	0	P-121	91309-425-0040	0	P-37	93891-05012-07	0	P-65
90545-300-0010	2	P-59	91351-KHE7-9000	0	P-35	93891-05016-08	0	P-91
90605-166-7210	0	P-35	91407-SA7-0040	0	P-91	93891-05030-07	0	P-107
90652-GY6-9010	0	P-21	91508-KV7-6710-M1	0	P-107	93892-04008-18	0	P-45
90652-KHE7-9000	0	P-91				93893-04012-18	0	P-59
90656-GY6-9110	0	P-57				93901-32220	0	P-101
90656-KDU-9000	0	P-111	92000			93901-32310	0	P-101
90677-GR1-0030	1	P-65				93901-34220	0	P-103
90677-GR1-0030	1	P-107	92101-05032-0H	0	P-37	93901-34320	0	P-107
90754-GC8-0000	0	P-73	92900-06050-0B	0	P-23	93903-25480	0	P-91
90912-KLF-00B	0	P-73				93903-34380	0	P-57
90913-KKC4-9000	0	P-119				93903-34380	0	P-65
90915-KKC4-9000	0	P-53	93000			93903-34380	0	P-89
			93404-06016-07	0	P-65	93903-34380	0	P-91
91000			93404-06016-07	0	P-107	93903-34380	0	P-103
			93404-06016-07	0	P-111	93903-34380	0	P-107
91001-KHE7-900	0	P-25	93404-06016-07	0	P-119	93903-34380	0	P-115
91001-KJ9-0060	0	P-29	93404-06020-07	0	P-65	93903-35220	0	P-119
								P-81

零件號碼索引

PART NO. INDEX

零件號碼 PART NO.	版數 VERSION	頁次 PAGE	零件號碼 PART NO.	版數 VERSION	頁次 PAGE	零件號碼 PART NO.	版數 VERSION	頁次 PAGE
93903-35220	0	P-91	94301-10160	0	P-25	95002-KN7-9100	1	P-31
93903-35380	0	P-51	94301-10160	0	P-31	95002-KN7-9100	1	P-119
93903-35380	0	P-57	94301-10160	0	P-41	95003-23031-60	0	P-93
93903-35380	0	P-89	94303-04065	0	P-39	9500B-KE2-7000	0	P-123
93903-45380	0	P-15	94401-25140-M1	0	P-27	95014-72204	0	P-97
93903-GY6-9000	0	P-65	94510-10000	0	P-39	95701-06012-08	0	P-51
93903-GY6-9000	0	P-85	94510-25000	0	P-41	95701-06012-08	0	P-61
93903-GY6-9000	0	P-89	94520-26000	0	P-31	95701-06012-08	0	P-69
93903-KEB7-9000	0	P-65	94520-28000	0	P-35	95701-06012-08	0	P-83
93903-KEB7-9000	0	P-107	94591-27000	0	P-67	95701-06012-08	0	P-85
			94591-KBF-900	2	P-23	95701-06012-08	0	P-89
			94601-17000	0	P-27	95701-06012-08	0	P-115
94000			94601-33000	0	P-35	95701-06012-08	0	P-119
			94605-KHD8-9000	0	P-121	95701-06014-08	0	P-83
94050-05080	0	P-107	94608-30000	0	P-121	95701-06016-02	0	P-15
94050-06080	0	P-23				95701-06016-07	0	P-119
94050-06080	0	P-61				95701-06016-08	0	P-119
94050-06080	0	P-67	95000			95701-06022-07	0	P-61
94050-06080	0	P-79				95701-06025-08	0	P-23
94050-06080	0	P-81	95001-35225-40	0	P-119	95701-06040-08	0	P-23
94050-06080	0	P-85	95002-02070	0	P-81	95701-08012-08	0	P-17
94050-06080	0	P-111	95002-02070	0	P-119	95701-08012-08	0	P-115
94050-06080	0	P-119	95002-02070	0	P-123	95701-08020-08	0	P-73
94050-08080	0	P-23	95002-02080	0	P-41	95701-08035-08	0	P-41
94050-08080	0	P-111	95002-02080	0	P-83	95701-08050-08	0	P-115
94101-06200	0	P-95	95002-02100	0	P-83	95701-KHC5-E000-IT	3	P-111
94101-06700	0	P-95	95002-02100	0	P-119	95801-08030-08	0	P-41
94101-08700	0	P-97	95002-02130	0	P-83	95801-08040-08	0	P-69
94111-06800	0	P-95	95002-02130	0	P-91	95801-08042-07	0	P-95
94251-08400	0	P-73	95002-02150	0	P-91	95801-10025-08	0	P-97
94251-08400	0	P-77	95002-50000	0	P-53	95801-10035-08	0	P-99
94251-08400	0	P-97	95002-70000	0	P-119	95801-10070-07	0	P-95
94301-08140	0	P-31	95002-KHE7-9000	0	P-23			
94301-10160	0	P-15	95002-KHE7-9000	0	P-31			
94301-10160	0	P-23	95002-KHE7-9000	0	P-119			

零件號碼索引

PART NO. INDEX

零件號碼 PART NO.	版數 VERSION	頁次 PAGE	零件號碼 PART NO.	版數 VERSION	頁次 PAGE	零件號碼 PART NO.	版數 VERSION	頁次 PAGE
96000			98200-31500	0	P-85	W9353-36000	0	P-47
			98200-33000	0	P-85	W9525-25250	0	P-47
96001-06008-07	0	P-95						
96001-06010-08	0	P-31						
96001-06010-08	0	P-95	99000			Y		
96001-06012-08	0	P-39						
96001-06014-08	0	P-83	99101-116-1020	0	P-45	Y1901-002-0200	0	P-45
96001-06016-08	0	P-17						
96001-06018-02	0	P-31						
96001-06018-08	0	P-23	D19KT			Z		
96001-06022-08	0	P-31						
96001-06028-08	0	P-31	D19KT-073-1200	0	P-45	Z062-0060	0	P-47
96001-06028-08	0	P-39						
96001-06032-08	0	P-17						
96001-06045-08	0	P-31	K					
96001-06050-08	0	P-17						
96001-06100-08	0	P-23	K446-002-0100	0	P-45			
96001-06125-08	0	P-31						
96100-60000-00	0	P-31						
96100-63020-00	0	P-17	N					
96100-63020-00	0	P-41						
96100-63040-00	1	P-17	N413-17E00	0	P-45			
96150-62040-10	0	P-99	N424-51B38	0	P-45			
96211-05000	0	P-69	N425-7AG01	0	P-45			
96211-08000	0	P-69	N426-33B00	0	P-45			
96220-20118	0	P-27						
96600-08015-10	1	P-39						
96600-KKC4-9000	0	P-73	S					
96600-KKC4-9000	0	P-77						
			S7860-112-B000	0	P-45			
98000								
			W					
98069-5791R-00	0	P-23						
98200-31000	0	P-85	W1470-MW0-7500	0	P-45			