

Thank you for purchasing this Dynojet kit. This kit has been developed for a motorcycle which is set to the parameters listed at the right in the "Stage" description. If your motorcycle does not meet any of these parameters please check with Dynojet before installation. For technical assistance contact your Dynojet distributor or call Dynojet U.S.A. (800)-992-4993

2191 Mendenhall Dr. Suite 105
 North Las Vegas, NV 89031
 TEL: 702-399-1423
 FAX: 702-399-1431
 8am-5pm Pacific Time
 Monday through Friday

Website Address
<http://www.dynojet.com>

The manufacturer and seller make no warranties express or implied which extend beyond the description of the goods contained herein. Any description of this product is for the purpose of identifying it and shall not be deemed to create an express warranty.



E2142.001

European Models Only

1990-92 Kawasaki ZZR600

Stage 1

For mildly tuned machines using the stock air-box, with stock or K&N filter. May also be used with a good aftermarket exhaust system
 K&N filter #KA-0013

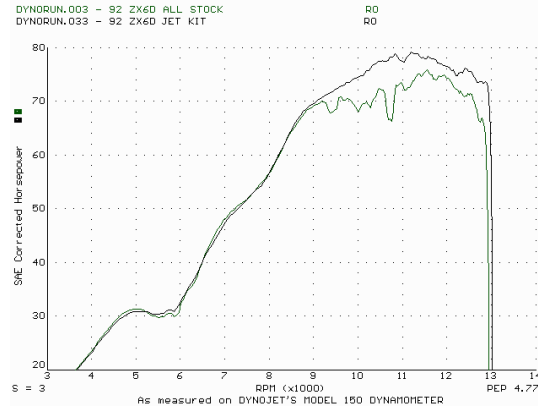

This graph shows a typical gain with a Dynojet jet kit.

WARNING

**NO SMOKING!
 NO OPEN FLAME!
 WHILE INSTALLING
 YOUR DYNOJET KIT**

Parts List

4	Main Jets	DJ136
4	Main Jets	DJ140
4	Main Jets	DJ144
4	Fuel Needles	DNO228
8	Adjusting Washers	DW0001
4	E-clips	DE0001
1	Glue	DA0001
4	Main Air Correctors	DCO201
1	Tool	DT001

STAGE ONE INSTRUCTIONS

DYNOJET
E2142.001

1. Remove vacuum slide from carbs. Remove stock needles & spacers, noting order of assembly (Fig.A).
2. Install Dynojet needles on groove #4, using all stock spacers. Install the Dynojet washers above the E-clip (2 per needle).
3. Remove the stock main jets and replace with the Dynojet mains provided. If you are running the stock exhaust use the DJ140 main jets, if you are running an aftermarket header or slip-on with high flowing baffle, use the DJ144 main jets. Be sure that the jets you are changing are the main jets.
4. Locate the main air jet passage (Fig. B). With the flat end facing into the carb, install the main air correctors provided (DCO201). Use the tool provided (DT001) to tap lightly in place. With the glue provided, lightly touch a dab on the outer edge of the air corrector. Allow glue to dry.
5. Locate the Fuel Mixture Screws (Fig. C). Carefully turn mixture screws clockwise until lightly seated, then turn out until you find your best idle. Our base setting is 3 turns.

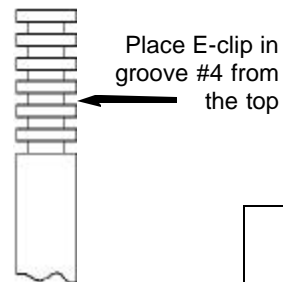

Fig. B

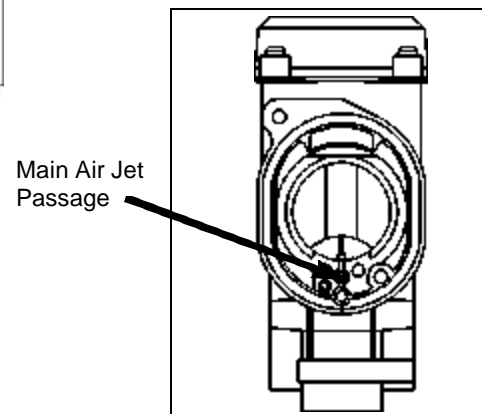

Fig. A

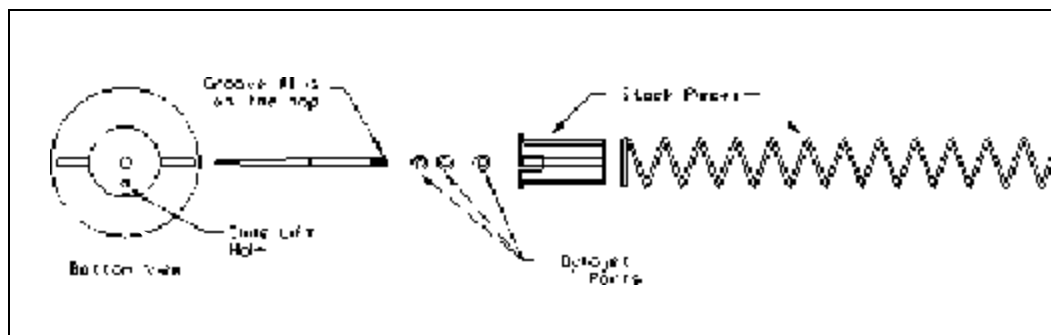

Fig. C

