

## OWNER'S MANUAL TD SERIES AMPLIFIERS



Use your smartphone to scan or visit [youtube.com/user/MTXThunderforce](https://www.youtube.com/user/MTXThunderforce) to learn how to properly install this amplifier.

## **PRODUCT INFORMATION**

Model # \_\_\_\_\_

Serial # \_\_\_\_\_

Dealer's Name \_\_\_\_\_

Date of Purchase \_\_\_\_\_

## **INTRODUCTION**

Thank you for purchasing an MTX Audio Hi-Performance amplifier. Proper installation matched with MTX speakers and subwoofers provide superior sound and performance for endless hours of enjoyment whether you are waking the neighbors or just out enjoying your tunes. Congratulations and enjoy the ultimate audio experience with MTX!

## **FEATURES**

- Compact Size
- Double Sided PCB
- Surface Mount Components
- Mosfet Design
- LPF and HPF Crossover
- Adjustable Bass Boost
- Noise Free Design
- Short, Thermal, and High/Low Voltage Protection

## **CONTROL FUNCTIONS**

1. **Speakers** - Connect speakers/subwoofers to these terminals. Be sure to check wire for proper polarity. Never connect the speaker cables to the chassis ground.
2. **+12 Volt Power** - Connect this terminal through a FUSE or CIRCUIT BREAKER to the positive terminal of the vehicle battery or the positive terminal of an isolated audio system battery.  
**WARNING:** Always protect this power cable by installing a fuse or circuit breaker of the appropriate size within 18 inches (45cm) of the battery terminal connection.
3. **Remote Turn On** - This terminal turns on the amplifier when (+) 12 volt is applied to it. Connect it to the remote turn on lead of the head unit or signal source.
4. **GND** - Connect this cable directly to the frame of the vehicle. Make sure the metal frame has been stripped of all paint down to the bare metal. Use the shortest distance possible. It is always a good idea to replace the factory ground at this time with a cable equal or larger than the new amplifier power cable. **CAUTION:** Do not connect this terminal directly to the vehicle battery ground terminal or any other factory ground points.
5. **RCA Input Jacks** - These RCA input jacks are for use with source units that have RCA outputs. A source unit with a minimum level of 200mV is required for proper operation. The use of high quality twisted pair cables is recommended to decrease the possibility of radiated noise entering the system.
6. **Gain Control** - The Gain control will match the amplifier's sensitivity to the source units signal voltage. The operating range is 5V to 200mV. **NOTE:** This is NOT a volume control.
7. **Low Pass Filter Control (Mono Block)** - This control is used to select the desired low pass x-over frequency. The frequency can be adjusted from 40Hz to 220Hz for all bass mono models.
8. **Subsonic Filter Control (Mono Block)** - This control can filter out unwanted low frequency from 10Hz (OFF) to 50Hz. This function should only be used with vented enclosures.

9. Bass Boost Level Switch (Mono Block) - This switch can boost bass level by 0dB, 6dB, or 12dB. The boost frequency is centered at 50Hz.
10. High Pass Filter (Full Range) - This controls the frequencies played for the front channels. Low frequencies can be cut off from OFF to 200Hz. At OFF position, no low frequencies cut off, meaning full range.
11. X-Over Mode and Frequency Control (Full Range) - These controls allow control over the frequencies played for the rear channels. There is an option for Low Pass, Full Range, or High Pass. In LP or HP mode, the crossover frequency can be tuned from 50Hz to 750Hz.
12. Power Indicator - This LED will light up when the amplifier is working properly.
13. Protection Indicator - The Red LED will light up and flash if there is a fault presented to the amplifier. Please disconnect the amplifier and resolve the fault before reconnecting the amplifier.

## PANEL LAYOUT

### 4-Channel Amplifier Panel Layout

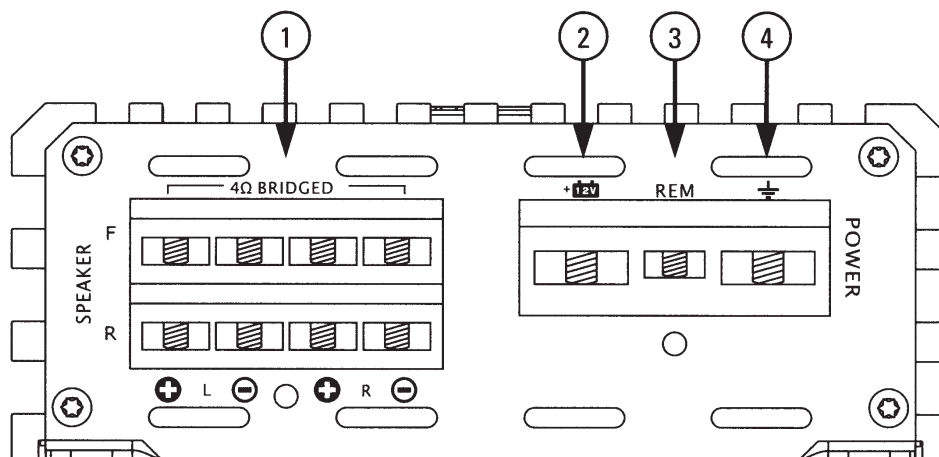
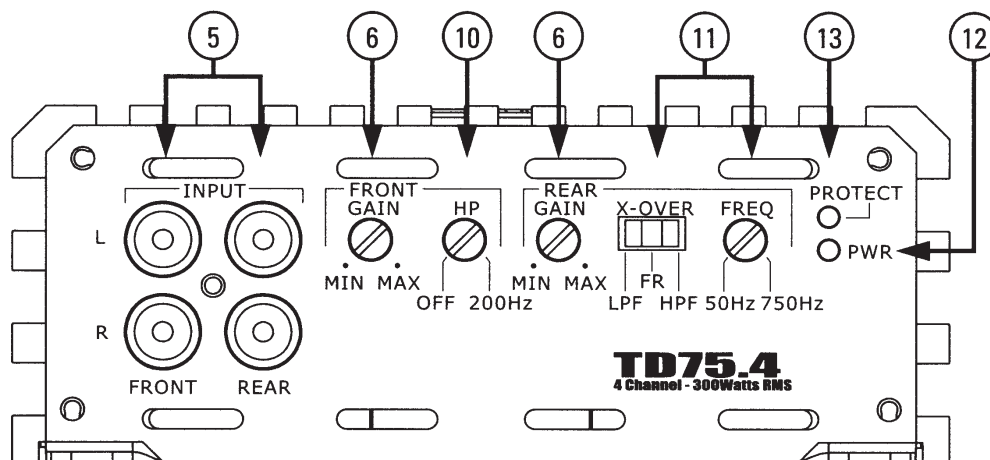

# PANEL LAYOUT

## Mono Block Amplifier Panel Layout

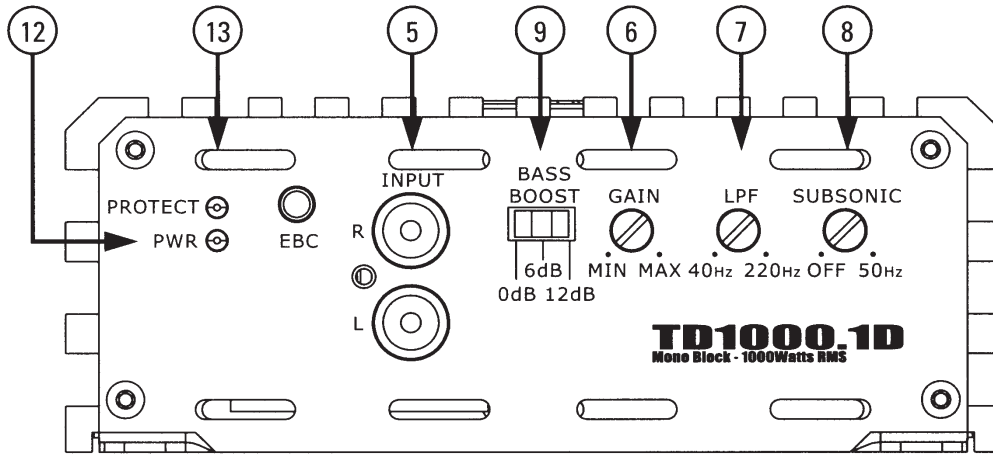

TD1000.1D/TD500.1D

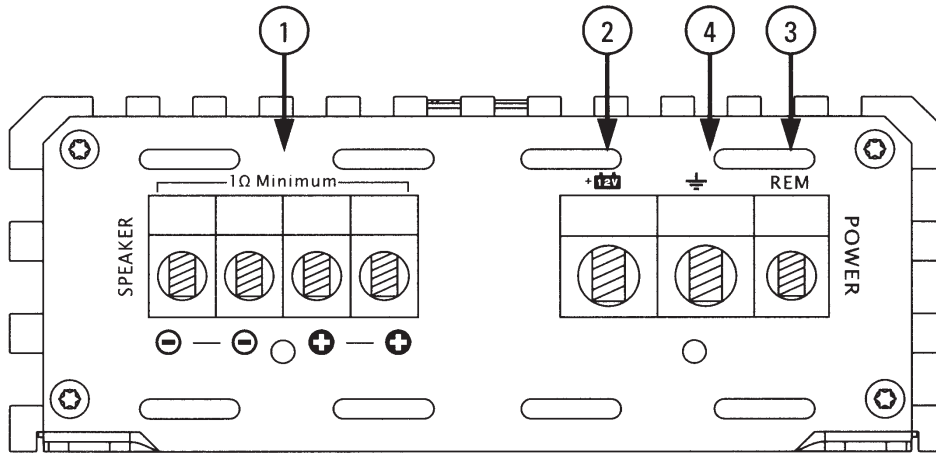

TD1000.1D

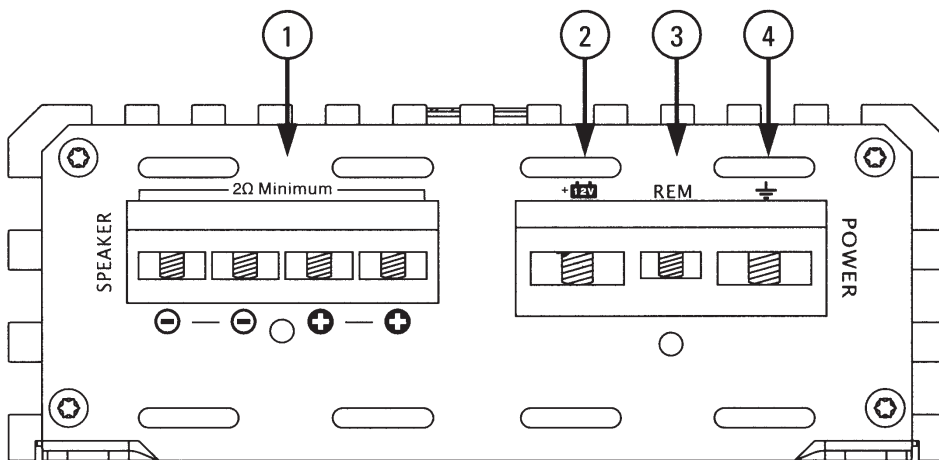

TD500.1D

## **INSTALLATION AND MOUNTING**

MTX recommends your new TD Series amplifier be installed by an Authorized MTX retailer. Any deviation from specified installation instructions can cause serious damage to the amplifier, speakers and/or vehicle's electrical system. Damage caused from improper installation is NOT covered under warranty. Please verify all connections prior to system turn on.

1. Disconnect the vehicle's negative battery cable.
2. Determine the mounting place for your MTX amplifier. Keep in mind there should be sufficient air flow for proper cooling. Mark the mounting holes from the amplifier to be drilled. Before drilling make sure all vehicle wires, gas lines, brake lines and gas tank are clear and will not interfere with installation. Drill the desired holes and mount the MTX amplifier.
3. Install a positive (+) power cable from the vehicle's battery through the firewall using a grommet or firewall bushing to avoid cable damage from sharp edges of the firewall. Run the cable through the interior of the vehicle and connect it to the amplifier's (+12V) terminal. Do not connect to the battery at this time. **NOTE:** Use only proper gauge wire for both positive and negative connections.
4. Install a circuit breaker or fuse within 18 inches of the battery. This effectively lowers the risk of severe damage to you or your vehicle in case of a short circuit or accident. Make sure the circuit breaker is switched off or the fuse is taken out of the fuse holder until all connections are made. Now connect your positive power cable to the positive battery terminal of the battery.
5. Grounding - Locate a proper ground point on the vehicle's chassis and remove all paint, dirt or debris to reveal a bare metal surface. Attach the ground wire to that contact point. Connect the opposite end of the ground wire to the (GND) terminal on the MTX amplifier.
6. Connect a Remote Turn-on wire from the source unit to the MTX amplifier's (REM) terminal. If the source unit does not have a dedicated Remote Turn-on lead, you may connect to the source unit's Power Antenna lead.
7. Supply the signal to your MTX amplifier by connecting the signal cables using high quality RCA to the corresponding outputs at the source unit and inputs of the amplifier.
8. Connect your speakers to your MTX amplifier's speaker terminals using the correct gauge speaker wire. Your MTX amp can drive a 2 $\Omega$  (TD75.4 & TD500.1D) and 1 $\Omega$  (TD1000.1D) minimum load for max power.
9. Double check all previous installation steps, in particular, wiring and component connections. Once verified, reconnect the vehicle's negative battery cable, turn the circuit breaker on or place the fuse in the fuse holder.

**NOTE:** Gain Levels on the amplifier should be turned all the way down (counter clockwise) before proceeding with adjustments.

## **TROUBLESHOOTING**

<b>Problem</b>	<b>Cause</b>	<b>Solution</b>
No LED Indication	No +12V at Remote Connection	Supply +12V to Terminal
	No +12V at Power Connection	Supply +12V to Terminal
	Insufficient Ground Connection	Verify Ground Connection
	Blown Power Fuse	Replace Fuse
Power LED On, No Output	Volume on Source Unit Off	Increase Volume on Source Unit
	Speaker Connections Not Made	Make Speaker Connections
	Gain Control on Amplifier Off	Turn Up Gain
	Signal Processing Units Off	Apply Power to Signal Processor
	All Speakers Blown	Replace Speakers
Output Distorted	Head Unit Volume Set Too High	Lower Head Unit Volume
	Amplifier Gain Set Too High	Lower Amplifier Gain
Balance Reversed	Speaker Wire L & R Reversed	Correct Speaker Wire Orientation
	RCA Inputs Reversed	Reverse RCA Inputs
Bass is Weak	Speakers Wired Out of Phase	Wire Speakers with Correct Phase
	Not Using MTX Subwoofers	Buy MTX Subwoofers
Blowing Fuses	Excessive Output Levels	Lower the Volume
	Amplifier Defective	Return for Service

## **WIRING DIAGRAM**

See page 26 for amplifier wiring diagrams.

## SPECIFICATIONS

Model	TD1000.1D	TD500.1D	TD75.4
Description	1000 W RMS Mono	500 W RMS Mono	4 x 75 W RMS
<b>RMS Power at 14.4V</b>			
1Ω Load	1000 W RMS	NA	NA
2Ω Load	600 W RMS	500 W RMS	4 x 100 W RMS
4Ω Load	350 W RMS	300 W RMS	4 x 75 W RMS
<b>Features</b>			
Input Level	0.2 - 5V	0.2 - 5V	0.2 - 5V
Frequency Response	10Hz - 220Hz	10Hz - 220Hz	15Hz - 25kHz
Low Pass Filter (LPF)	40Hz - 220Hz	40Hz - 220Hz	50Hz - 750Hz (Rear)
High Pass Filter (HPF)	NA	NA	10Hz - 200Hz (Front) 50Hz - 750Hz (Rear)
Subsonic Filter	10Hz - 50Hz	10Hz - 50Hz	NA
THD at 4Ω Load 30% Rated Power	<0.3%	<0.3%	<0.05%
Signal-to-Noise Ratio	>80dB	>80dB	>80dB
Bass Boost	0 - 6dB - 12dB Switchable	0 - 6dB - 12dB Switchable	NA
Best Efficiency at 4Ω	>80%	>80%	>60%
Minimum Load	1Ω	2Ω	2Ω
External Bass Control (EBC) Optional Remote	Yes	Yes	NA
Low Voltage Protection	Yes, Protect <8V	Yes, Protect <8V	Yes, Protect <8V
Short Circuit Test @ Max Power	Pass	Pass	Pass
Overheat Protect Temperature	Protect at 80°C / 176°F	Protect at 80°C / 176°F	Protect at 80°C / 176°F
Components & PCB	SMD Parts / Double Sided FR-4 PCB	SMD Parts / Double Sided FR-4 PCB	SMD Parts / Double Sided FR-4 PCB
<b>Dimensions</b>			
Height	2.13" (54mm)	2.13" (54mm)	2.13" (54mm)
Width	5.51" (140mm)	5.51" (140mm)	5.51" (140mm)
Length	10.28" (261mm)	7.24" (184mm)	10.04" (255mm)

# WIRING DIAGRAM

## Mono Block Amplifier Wiring (Single Subwoofer Load)

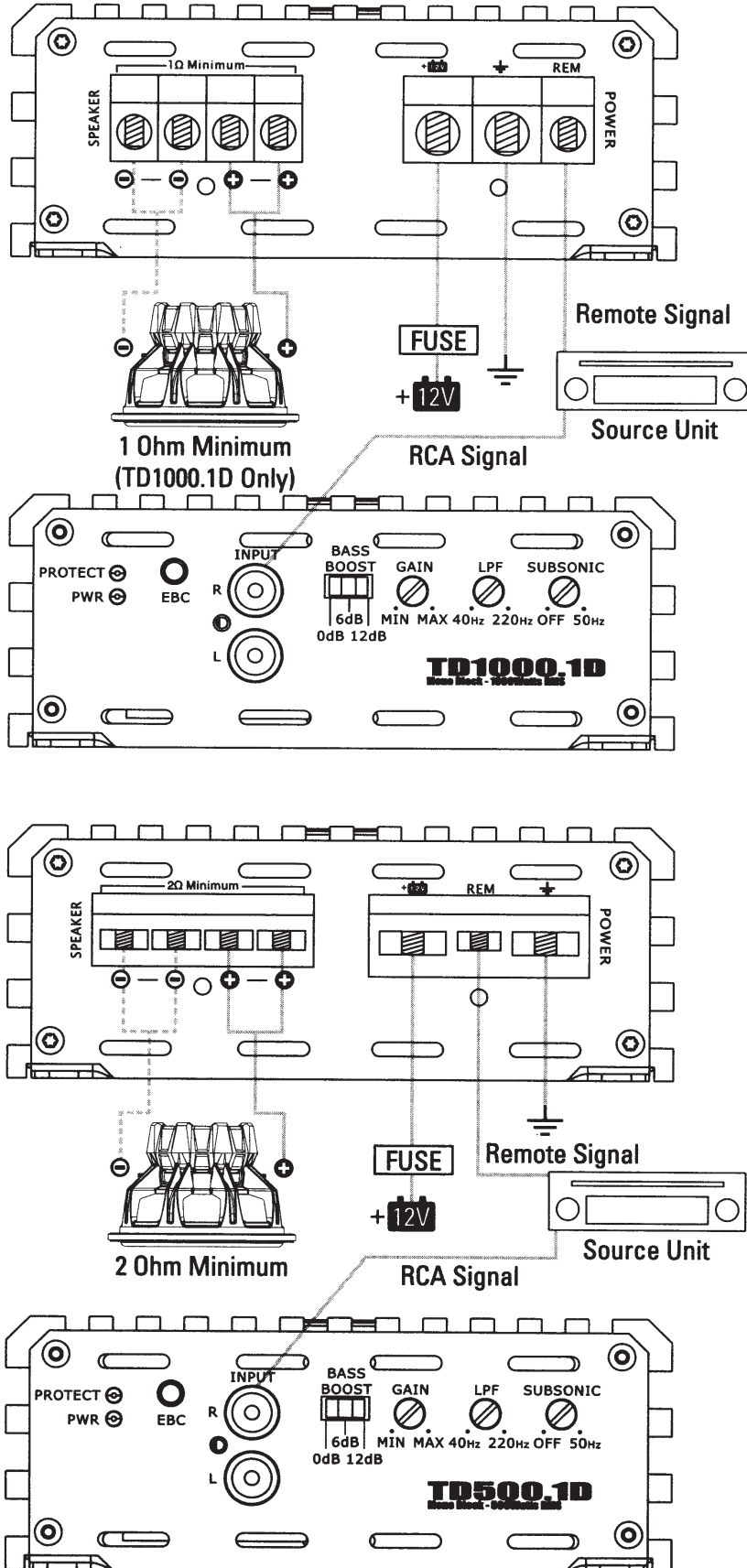



## WIRING DIAGRAM

### Mono Block Amplifier Wiring (Multi-Subwoofer Load)

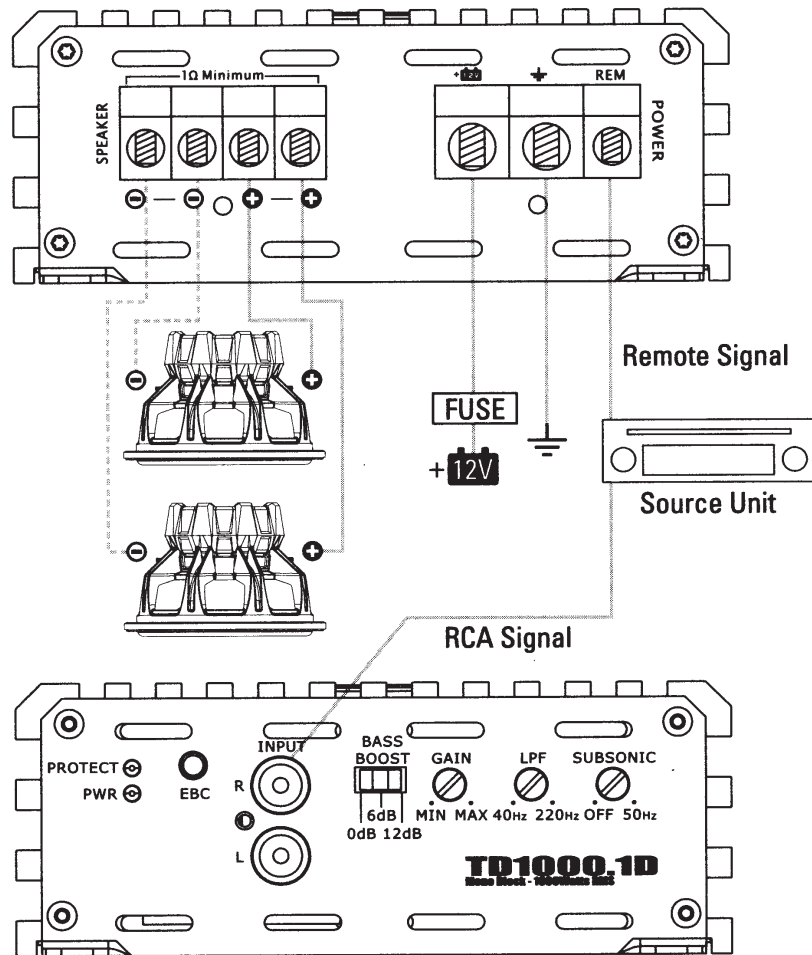

**NOTE:** Equivalent parallel woofer load cannot be less than the minimum load rating. The two negative terminals are paralleled inside the amplifiers, as are the two positive terminals. These are monoblock amplifiers, not multi-channel amplifiers. The minimum load for the TD500.1D amplifier is 2Ω. The minimum load for the TD1000.1D amplifier is 1Ω.

**NOTA:** La carga equivalente de woofers paralelos no puede ser menos que el valor nominal de la carga. Las dos terminales negativas están en paralelo dentro de los amplificadores y también las terminales positivas. Estos son amplificadores de monobloque, no amplificadores multicanal. La carga mínima para el amplificador TD500.1D es 2 Ω. La carga mínima para el amplificador TD1000.1D es 1 Ω.

**OBSERVAÇÃO:** A carga paralela equivalente do woofer não pode ser menor que a carga nominal mínima. Os dois terminais negativos, assim como os terminais positivos, estão em paralelo dentro dos amplificadores. Os amplificadores são monobloco e não amplificadores multicanais. A carga mínima do amplificador TD500.1D é 2Ω. A carga mínima do amplificador TD1000.1D é 1Ω.

**REMARQUE :** Une charge de caisson de graves en parallèle ne peut être inférieure à la valeur nominale minimale de charge. Les deux bornes négatives sont mises en parallèle à l'intérieur des amplificateurs, comme le sont les deux bornes positives. Ce sont des amplificateurs monoblocs et non des amplificateurs multi-canaux. La charge minimale pour l'amplificateur TD500.1D est de 2 Ω. La charge minimale pour l'amplificateur TD1000.1D est de 1 Ω.

# WIRING DIAGRAM

## TD75.4 Amplifier Wiring (4-Channel Mode)

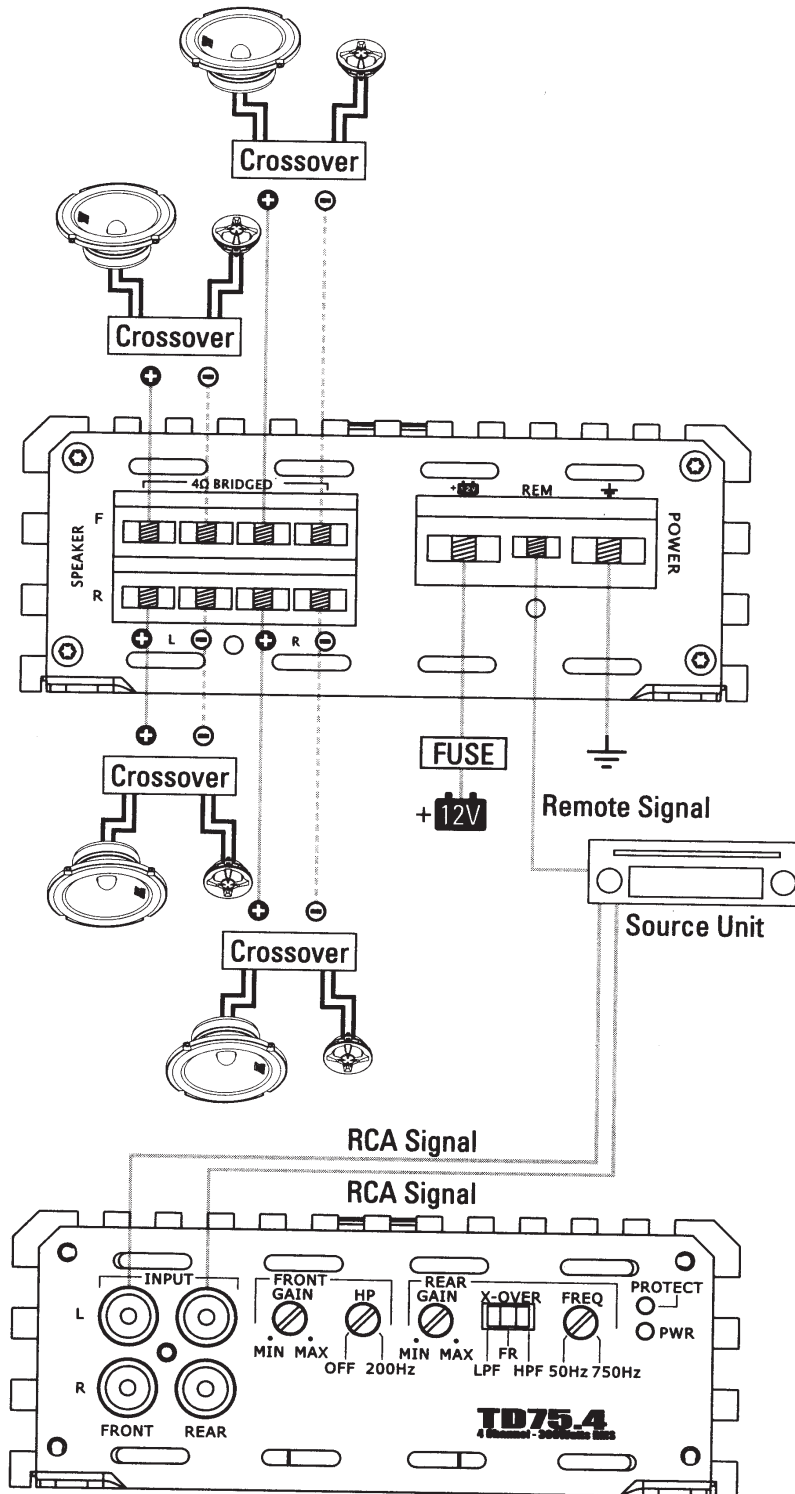

# WIRING DIAGRAM

## TD75.4 Amplifier Wiring (3-Channel Mode)

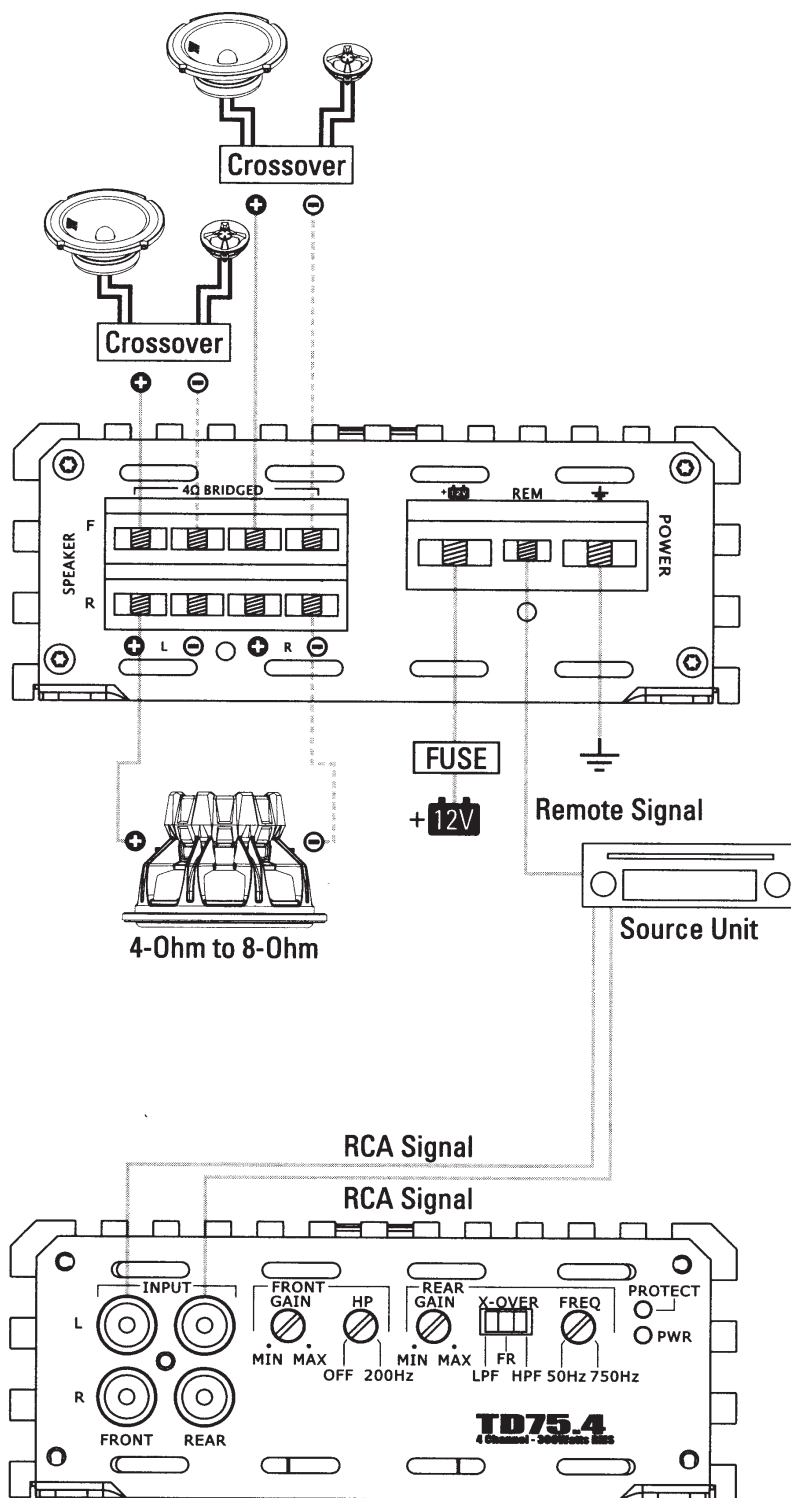

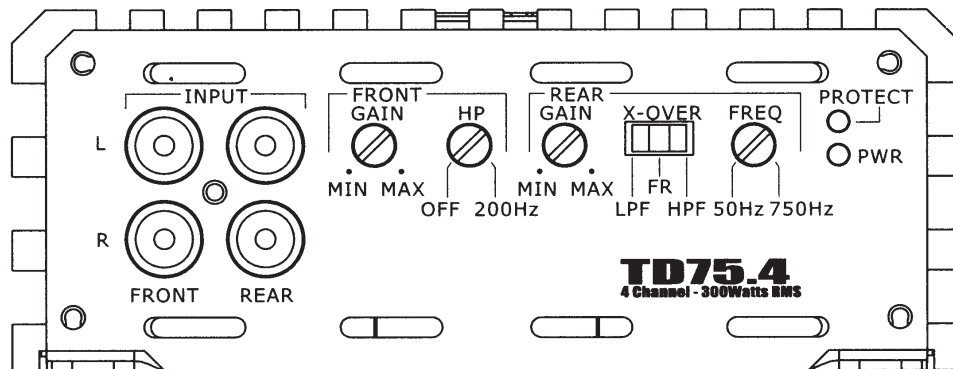
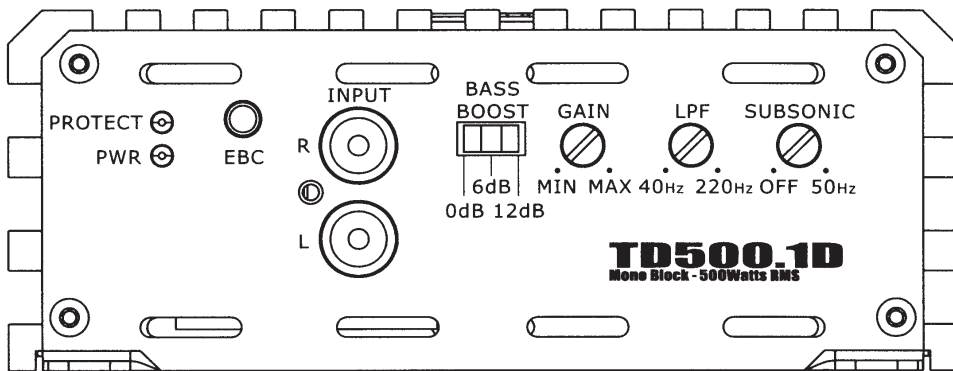
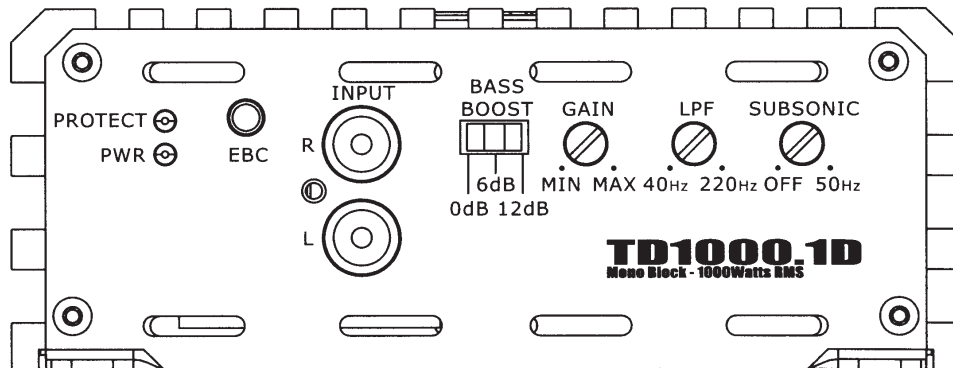

© 2011 Mitek Corporation. All rights reserved. MTX is a trademark of Mitek Corporation. Designed and Engineered in the U.S.A.

Due to continual product development, all specifications are subject to change without notice.

MTX Audio, 4545 East Baseline Rd. Phoenix, AZ 85042 U.S.A.

MTX004230 RevA 12/11

NDM642



For Proper Performance and Safety, MTX Recommends Installing an Inline Fuse per the Owner's Manual Instructions According to the Following.

TD1000.1D	100A Fuse
TD500.1D	60A Fuse
TD75.4	60A Fuse

MTX Recommends Using a StreetWires Fuse and Fuse Holder for Your Installation or a StreetWires Amplifier Kit Which Includes the Fuse and Fuse Holder.

TD1000.1D	ZN3K-04
TD500.1D	ZN3K-04
TD75.4	ZN3K-04

MTX Will Extend Your Manufacturer's Warranty By One (1) Year When You Use the Proper StreetWires Amplifier Kit to Connect Your Amplifier.