

MAH22PD

MAYTAG® COMMERCIAL ENERGY ADVANTAGE™ HIGH-EFFICIENCY FRONT-LOAD WASHER



LEGENDARY MAYTAG DEPENDABILITY

Maximizing your equipment investment for over a half century.

- ▶ **MODIFIED ENERGY FACTOR 2.25**
- ▶ **WATER FACTOR 4.34**
- ▶ **CEE TIER III RATED**



* Shown with optional pedestal.

A COMPLETE LINE OF ENERGY-EFFICIENT SOLUTIONS

Maytag built the first appliance ever to receive the ENERGY STAR® label. Today we offer a complete line of high-efficiency commercial laundry appliances — from industry-leading energy-efficient dryers to highly efficient ENERGY STAR®-qualified washers — to help you save money and build profits.

FOR YOUR CUSTOMERS:

- Large Capacity For Bulky Items — 3.1 cu. ft.
- High-Speed Extraction Cuts Drying Time (as high as 1,000 RPMs)
- Extra-Large Door Opening
- Easy-To-Use One-Touch Cycle Selection
- Flexible Wash Options
- Time Remaining Display
- Automatic Detergent, Softener And Bleach Dispenser
- Large Window For Convenience
- Tilted Front Controls For Easy Viewing
- ADA Compliant With Optional Pedestal

FOR YOUR OPERATION:

- High Efficiency Design Meets CEE Tier III Rating
- TurboWash™ System Delivers Better Cleaning With Less Average Water Use Per Cycle
- Super Cycle Option Increases Revenue
- Anti-Microbial Bellows
- Self-Diagnostic Feature Cuts Service Cost And Minimizes Downtime
- Accu Trac® Audit System With Two-Way Data Communication
- Debit Card Compatibility
- Advanced Computer Trac® Controls Allow For Easy Programming
- Simple Soft-Mount Design For Easy Installation
- Dual Coin-Drop Option

BUILT-TO-LAST™ FEATURES:

- Porcelain-Enamel Top With Backsplash
- Precision Endurance Drive
- Controlled Induction Motor
- High Security Vault
- Best Warranty In The Business — 5 Years All Parts

LAUNDRY SOLUTIONS
YOU CAN *DEPEND* ON.

**SAVE UP TO 60% YEARLY* ON ENERGY,
WATER AND SEWER COSTS.**

visit maytagcommerciallaundry.com

*Maytag Commercial front-load washer compared to commercial top-load washer. Individual savings may vary.

CLP798B



OUR COMMITMENT TO DEPENDABLE QUALITY

At Maytag, we believe durable goods should remain just that. That's why every Maytag® product is constructed of the highest-quality materials and with the utmost in precision craftsmanship. It's also why we stand behind our equipment with solid service and support from our professional Maytag laundry suppliers. Simply put, when you choose Maytag® products, you ensure your peace of mind.



MAH22PD

MAYTAG® COMMERCIAL ENERGY ADVANTAGE™ HIGH-EFFICIENCY FRONT-LOAD WASHER

Maytag® Energy Advantage™ Front-Load Washer MICROPROCESSOR COIN-DROP

WASHER SPECIFICATIONS	
MODEL	MAH22PD
MOTOR	
Variable-speed, reversible, thermoprotected, high-efficiency, controlled induction	•
Wash — HP (kw)	.09 (.07)
Extract — HP (kw)	.54 (.40)
Average kWh per cycle	.054
APPROXIMATE WATER USAGE — gallons (liters)	
Average hot water usage, hot water cycle	3.4 (12.8)
Average hot water usage, warm water cycle	1.6 (6.1)
Average total water usage per cycle	13.2 (49.9)*
ELECTRICAL RATING	
Domestic model — voltage	120V/60Hz
Export model — voltage	220-240V/50Hz
BREAKER/FUSE REQUIREMENTS	
Domestic amps	15
Export amps	10
CYLINDER	
Volume — cu. ft. (liters)	3.1 (88)
Diameter — in. (mm)	21.6 (547)
Depth — in. (mm)	13.4 (341)
DOOR OPENING	
In. (mm)	14.2 (361)
WASH SPEED	
RPM	40
EXTRACT SPEED	
Maximum rpm	1,000
Maximum g-force	306
OPERATING PRESSURE	
Psi (bar)	20-100 (1-8)
INLET HOSE	
Ft. (m)	4 (1.22)
DRAIN HOSE	
Ft. (m)	6 (1.83)
ADJUSTABLE LEVELING LEGS	•
APPROXIMATE WEIGHT	
Crated — lbs. (kg)	253 (115)
Uncrated — lbs. (kg)	244 (111)
DIMENSIONS	
Width — in. (mm)	27 (685.8)
Depth — in. (mm) includes handle	29.25 (743)
Height — in. (mm)	45.67 (1160)**

* Average based on DOE J1 testing with factory preset cycles.

** Height at metercase top does not include pedestal.

Dimensions are for planning purposes only. See specific instructions for proper installation. Because of continuous product improvement, Maytag reserves the right to change specifications without notice.

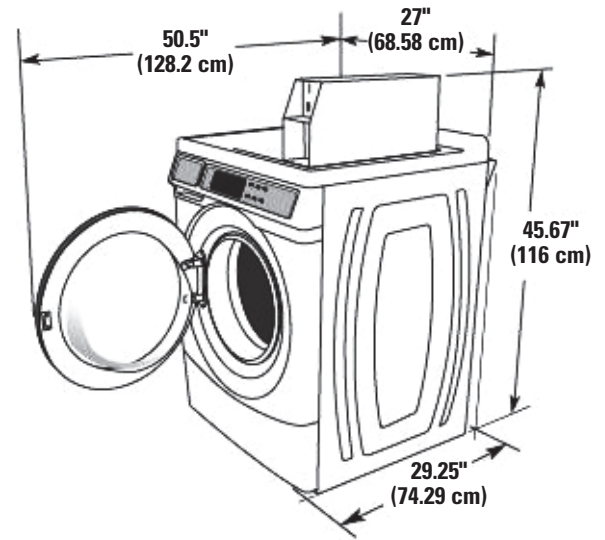

NEW YORK CITY M.E.A.



BEAB Approved



THE BEST WARRANTY IN THE BUSINESS — 5 YEARS ON ALL PARTS

For a period from the date of original purchase through the time listed above, the designated parts that fail in normal commercial use will be repaired or replaced free of charge for the part itself, with the owner paying all other costs, including labor, transportation and customs duty. Chemical damage is excluded from all warranty coverage.

See complete warranty for details.