

Nikon

DIGITAL CAMERA

COOLPIX S8100

User's Manual

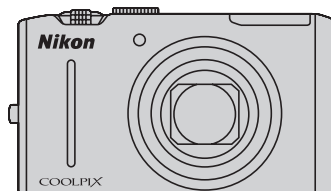

En

Trademark Information

- Microsoft, Windows and Windows Vista are either registered trademarks or trademarks of Microsoft Corporation in the United States and/or other countries.
- Macintosh, Mac OS, and QuickTime are trademarks of Apple Inc.
- Adobe and Acrobat are registered trademarks of Adobe Systems Inc.
- SDXC, SDHC and SD Logos are trademarks of SD-3C, LLC.
- PictBridge is a trademark.
- HDMI, **HDMI** logo and High-Definition Multimedia Interface are trademarks or registered trademarks of HDMI Licensing LLC.
- All other trade names mentioned in this manual or the other documentation provided with your Nikon product are trademarks or registered trademarks of their respective holders.

AVC Patent Portfolio License

This product is licensed under the AVC Patent Portfolio License for the personal and non-commercial use of a consumer to (i) encode video in compliance with the AVC standard ("AVC video") and/or (ii) decode AVC video that was encoded by a consumer engaged in a personal and non-commercial activity and/or was obtained from a video provider licensed to provide AVC video. No license is granted or shall be implied for any other use. Additional information may be obtained from MPEG LA, L.L.C.

See <http://www.mpegla.com>.

Introduction	
First Steps	
Basic Photography and Playback: 📷 (Auto) Mode	
More on Shooting	
More on Playback	
Editing Images	
Movie Recording and Playback	
Connecting to Televisions, Computers and Printers	
Basic Camera Setup	
Caring for the Camera	
Technical Notes and Index	

For Your Safety

To prevent damage to your Nikon product or injury to yourself or to others, read the following safety precautions in their entirety before using this equipment. Keep these safety instructions where all those who use the product will read them.



This icon marks warnings, information that should be read before using this Nikon product, to prevent possible injury.

WARNINGS

Turn off in the event of malfunction

Should you notice smoke or an unusual smell coming from the camera or Charging AC Adapter, unplug the Charging AC Adapter and remove the battery immediately, taking care to avoid burns. Continued operation could result in injury. After removing or disconnecting the power source, take the equipment to a Nikon-authorized service representative for inspection.

Do not disassemble

Touching the internal parts of the camera or Charging AC Adapter could result in injury. Repairs should be performed only by qualified technicians. Should the camera or Charging AC Adapter break open as the result of a fall or other accident, take the product to a Nikon-authorized service representative for inspection, after unplugging the product and/or removing the battery.

Do not use the camera or Charging AC Adapter in the presence of flammable gas

Do not use electronic equipment in the presence of flammable gas, as this could result in explosion or fire.

Handle the camera strap with care

Never place the strap around the neck of an infant or child.

Keep out of reach of children

Particular care should be taken to prevent infants from putting the battery or other small parts into their mouths.

Observe caution when handling the battery

The battery may leak, overheat, or explode if improperly handled.

Observe the following precautions when handling the battery for use in this product:

- Before replacing the battery, turn the product off. If you are using the Charging AC Adapter/AC adapter, be sure it is unplugged.
- Use only a Rechargeable Li-ion Battery EN-EL12 (supplied). Charge the battery by using a camera that supports battery charging or by using a Battery Charger MH-65 (available separately). To charge the battery with the camera, use either Charging AC Adapter EH-68P/EH-68P (AR) (supplied) or the **Charge by computer** function.
- When inserting the battery, do not attempt to insert it upside down or backwards.
- Do not short or disassemble the battery or attempt to remove or break the battery insulation or casing.
- Do not expose the battery to flame or to excessive heat.
- Do not immerse in or expose to water.
- Replace the terminal cover when transporting the battery. Do not transport or store with metal objects such as necklaces or hairpins.
- The battery is prone to leakage when fully discharged. To avoid damage to the product, be sure to remove the battery when no charge remains.
- Discontinue use immediately should you notice any change in the battery, such as discoloration or deformation.

Observe the following precautions when handling the Charging AC Adapter

- If liquid from the damaged battery comes in contact with clothing or skin, rinse immediately with plenty of water.
- Keep dry. Failure to observe this precaution could result in fire or electric shock.
- Dust on or near the metal parts of the plug should be removed with a dry cloth. Continued use could result in fire.
- Do not handle the plug or go near the Charging AC Adapter during lightning storms. Failure to observe this precaution could result in electric shock.
- Do not damage, modify, forcibly tug or bend the USB cable, place it under heavy objects, or expose it to heat or flames. Should the insulation be damaged and the wires become exposed, take it to a Nikon-authorized service representative for inspection. Failure to observe these precautions could result in fire or electric shock.
- Do not handle the plug or Charging AC Adapter with wet hands. Failure to observe this precaution could result in electric shock.
- Do not use with travel converters or adapters designed to convert from one voltage to another or with DC-to-AC inverters. Failure to observe this precaution could damage the product or cause overheating or fire.

 **Use appropriate cables**

When connecting cables to the input and output jacks, use only the cables provided or sold by Nikon for the purpose, to maintain compliance with product regulations.

 **Handle moving parts with care**

Be careful that your fingers or other objects are not pinched by the lens cover or other moving parts.

 **CD-ROMs**

The CD-ROMs supplied with this device should not be played back on audio CD equipment. Playing CD-ROMs on an audio CD player could cause hearing loss or damage the equipment.

 **Observe caution when using the flash**

Using the flash close to your subject's eyes could cause temporary visual impairment. Particular care should be observed if photographing infants, when the flash should be no less than 1 m (3 ft. 4 in.) from the subject.

 **Do not operate the flash with the flash window touching a person or object**

Failure to observe this precaution could result in burns or fire.

 **Avoid contact with liquid crystal**

Should the monitor break, care should be taken to avoid injury caused by broken glass and to prevent liquid crystal from the monitor touching the skin or entering the eyes or mouth.

 **Turn the power off when using inside an airplane or the hospital**

Turn the power off while inside the airplane during take off or landing. Follow the instructions of the hospital when using while in a hospital. The electromagnetic waves given out by this camera may disrupt the electronic systems of the airplane or the instruments of the hospital.

Notices

Notices for Customers in the U.S.A.

IMPORTANT SAFETY INSTRUCTIONS - SAVE THESE INSTRUCTIONS.

DANGER - TO REDUCE THE RISK OF FIRE OR ELECTRIC SHOCK, CAREFULLY FOLLOW THESE INSTRUCTIONS

For connection to a supply not in the U.S.A., use an attachment plug adapter of the proper configuration for the power outlet if needed.

The power supply unit is intended to be correctly orientated in a vertical or floor mount position.

Federal Communications Commission (FCC) Radio Frequency Interference Statement

This equipment has been tested and found to comply with the limits for a Class B digital device, pursuant to Part 15 of the FCC rules. These limits are designed to provide reasonable protection against harmful interference in a residential installation. This equipment generates, uses, and can radiate radio frequency energy and, if not installed and used in accordance with the instructions, may cause harmful interference to radio communications. However, there is no guarantee that interference will not occur in a particular installation. If this

equipment does cause harmful interference to radio or television reception, which can be determined by turning the equipment off and on, the user is encouraged to try to correct the interference by one or more of the following measures:

- Reorient or relocate the receiving antenna.
- Increase the separation between the equipment and receiver.
- Connect the equipment into an outlet on a circuit different from that to which the receiver is connected.
- Consult the dealer or an experienced radio/television technician for help.



Nikon

COOLPIX S8100

CAUTIONS

Modifications

The FCC requires the user to be notified that any changes or modifications made to this device that are not expressly approved by Nikon Corporation may void the user's authority to operate the equipment.

Interface Cables

Use the interface cables sold or provided by Nikon for your equipment. Using other interface cables may exceed the limits of Class B Part 15 of the FCC rules.

Notice for customers in the State of California

WARNING

Handling the cord on this product will expose you to lead, a chemical known to the State of California to cause birth defects or other reproductive harm.

Wash hands after handling.

Nikon Inc.,

1300 Walt Whitman Road
Melville, New York 11747-3064
USA

Tel: 631-547-4200

Notice for customers in Canada

CAUTION

This Class B digital apparatus complies with Canadian ICES-003.

ATTENTION

Cet appareil numérique de la classe B est conforme à la norme NMB-003 du Canada.

Notices for customers in Europe

CAUTIONS

RISK OF EXPLOSION IF BATTERY IS REPLACED BY AN INCORRECT TYPE.

DISPOSE OF USED BATTERIES ACCORDING TO THE INSTRUCTIONS.

This symbol indicates that this product is to be collected separately.

The following apply only to users in European countries:

- This product is designated for separate collection at an appropriate collection point. Do not dispose of as household waste.
- For more information, contact the retailer or the local authorities in charge of waste management.



This symbol on the battery indicates that the battery is to be collected separately.

The following apply only to users in European countries:

- All batteries, whether marked with this symbol or not, are designated for separate collection at an appropriate collection point. Do not dispose of as household waste.
- For more information, contact the retailer or the local authorities in charge of waste management.



Table of Contents





For Your Safety	ii
WARNINGS	ii
Notices	v
<hr/>	
Introduction	1
About This Manual	1
Information and Precautions	2
Parts of the Camera	4
The Camera Body	4
The Monitor	6
Main Features of the Operation Controls	8
Using Camera Menus	10
Switching Between Tabs	11
The Shutter-release Button	11
Attaching the Camera Strap	11
<hr/>	
First Steps	12
Inserting the Battery	12
Removing the Battery	13
Charging the Battery	14
Turning On and Off the Camera	17
Setting Display Language, Date, and Time	18
Inserting Memory Cards	20
Removing Memory Cards	20
<hr/>	
Basic Photography and Playback:  (Auto) Mode	22
Step 1 Turn the Camera On and Select  (Auto) Mode	22
Indicators Displayed in  (Auto) Mode	23
Step 2 Frame a Picture	24
Using the Zoom	25
Step 3 Focus and Shoot	26
Step 4 Playing Back and Deleting Images	28
Playing Back Images (Playback Mode)	28
Deleting Unwanted Images	29
Using the Flash	30
Raising and Lowering the Flash	30
Setting the Flash Mode	31
Taking Pictures with the Self-timer	33
Taking Pictures with the Smile Timer	34
Macro Mode	36
Adjusting Brightness (Exposure Compensation), Vividness, and Hue	37
Operating the Creative Slider	38
Adjusting Exposure Compensation	41

Table of Contents

More on Shooting	42
Selecting a Shooting Mode (Mode Dial)	42
Changing  (Auto) Mode Settings (Shooting Menu)	43
Image Mode (Image Quality/Image Size)	44
White Balance (Adjusting Hue)	46
Metering	48
ISO Sensitivity	49
AF Area Mode	50
Autofocus Mode	54
Shooting Suited to Scenes (Scene Mode)	55
Shooting in the Scene Mode Selected by the Camera (Scene Auto Selector)	56
Choosing a Scene and Shooting (Scene Mode Types and Characteristics)	58
Shooting for a Panorama	68
Focusing on a Moving Subject (Subject Tracking Mode)	70
Changing Subject Tracking Mode Settings	72
Burst Shooting (Continuous Shooting Mode)	73
Changing Continuous Shooting Mode Settings	75
Camera Settings that Cannot Be Applied Simultaneously	78
More on Playback	80
Operations in Full-frame Playback Mode	80
Displaying the Histogram and Shooting Information	82
Playing Images Captured Using Continuous Shooting Mode (Sequence)	83
Viewing Multiple Images: Thumbnail Playback	85
Calendar Display	87
Taking a Closer Look: Playback Zoom	88
Playing Back Images by Category	90
Sorting Favorite Images (Favorite Pictures Mode)	92
Adding Images to an Album	92
Viewing Images in an Album	94
Removing Images From an Album	95
Using Favorite Pictures Mode	96
Favorite Pictures Menu	96
Changing the Album Icons	97
Finding Images in Auto Sort Mode	100
Viewing Images in Auto Sort Mode	100
Operations in Auto Sort Mode	103
Auto Sort Menu	103
Viewing Images by Date (List by Date)	104
Viewing Images in List by Date Mode	104
Operations in List by Date Mode	106
List by Date Menu	106













Playback Options: Playback Menu	107
 Print Set (Creating a DPOF Print Order)	109
 Slide Show	113
 Protect	114
 Rotate Image	116
 Voice Memo	117
 Copy (Copy Between Internal Memory and Memory Card)	119
 Sequence Display Options	121
 Choose Key Picture	121
Editing Images	122
Editing Functions	122
Image Editing	124
 Quick Retouch: Enhancing Contrast and Saturation	124
 D-Lighting: Enhancing Brightness and Contrast	125
 Skin Softening: Softening Skin Tones	126
 Small Picture: (Decreasing Image Size)	127
 Crop: Creating a Cropped Copy	128
Movie Recording and Playback	129
Recording Movies	129
Capturing Still Images While Recording Movies	131
Changing Movie Recording Settings	132
Movie of Movie Options (Normal Speed Movie Type)	134
Autofocus Mode	135
Wind Noise Reduction	136
Recording Movies in Slow Motion and Fast Motion (HS Movie)	137
Changing HS Movie Settings (HS Movie Type)	139
Movie Playback	140
Deleting Movies	140
Editing Movies	141
Connecting to Televisions, Computers and Printers	143
Connecting to a TV	143
Connecting to a Computer	145
Before Connecting the Camera	145
Transferring Images from a Camera to a Computer	146
Charging While Connecting to a Computer	150
Connecting to a Printer	151
Connecting the Camera to a Printer	152
Printing Images One at a Time	153
Printing Multiple Images	154

Table of Contents

Basic Camera Setup	157
Setup Menu	157
Welcome Screen	159
Date	160
Monitor Settings	163
Date Imprint (Imprinting Date and Time)	165
Vibration Reduction	166
Motion Detection	168
AF Assist	169
Digital Zoom	169
Sound Settings	170
Auto Off	171
Format Memory/Format Card	172
Language	173
TV Settings	173
Charge by Computer	174
Blink Warning	175
Reset All	177
Firmware Version	179

Caring for the Camera	180
Maximizing Camera Life and Performance	180
Cleaning	182
Storage	182

Technical Notes and Index	183
Optional Accessories	183
Approved Memory Cards	184
Image/Sound File and Folder Names	185
Error Messages	186
Troubleshooting	191
Specifications	198
Supported Standards	201
Index	202

About This Manual

Thank you for your purchase of a Nikon COOLPIX S8100 digital camera. This manual was written to help you enjoy taking pictures with your Nikon digital camera. Read this manual thoroughly before use, and keep it where all those who use the product will read it.

Symbols and Conventions

To make it easier to find the information you need, the following symbols and conventions are used:



This icon marks cautions, information that should be read before use, to prevent damage to the camera.



This icon marks tips, additional information that may be helpful when using the camera.



This icon marks notes, information that should be read before using the camera.



This icon indicates that more information is available elsewhere in this manual.

Notations

- Secure Digital (SD) memory card, SDHC memory card, and SDXC memory card are referred to as “memory card.”
- The setting at the time of purchase is referred to as the “default setting.”
- The names of menu items displayed in the camera monitor, and the names of buttons or messages displayed on a computer monitor appear in bold.

Screen Samples

In this manual, images are sometimes omitted from monitor display samples so that monitor indicators can be more clearly shown.

Illustrations and Screen Display

Illustrations and text displays shown in this manual may differ from actual display.

Internal Memory and Memory Cards

Pictures taken with this camera can be stored in the camera’s internal memory or on removable memory cards. If a memory card is inserted, all new pictures will be stored on the memory card and delete, playback, and format operations will apply only to the pictures on the memory card. The memory card must be removed before the internal memory can be formatted or accessed for picture storage, deletion, or viewing.

Information and Precautions

Life-Long Learning

As part of Nikon's "Life-Long Learning" commitment to ongoing product support and education, continually updated information is available online at the following sites:

- For users in the U.S.A.: <http://www.nikonusa.com/>
- For users in Europe and Africa: <http://www.europe-nikon.com/support/>
- For users in Asia, Oceania, and the Middle East: <http://www.nikon-asia.com/>

Visit these sites to keep up-to-date with the latest product information, tips, answers to frequently asked questions (FAQs), and general advice on digital imaging and photography. Additional information may be available from the Nikon representative in your area. Visit the site below for contact information:

<http://imaging.nikon.com/>

Use Only Nikon Brand Electronic Accessories

Nikon COOLPIX cameras are designed to the highest standards and include complex electronic circuitry. Only Nikon brand electronic accessories (including battery charger, batteries, Charging AC Adapter, and AC adapters) certified by Nikon specifically for use with this Nikon digital camera are engineered and proven to operate within the operational and safety requirements of this electronic circuitry.

THE USE OF NON-NIKON ELECTRONIC ACCESSORIES COULD DAMAGE THE CAMERA AND MAY VOID YOUR NIKON WARRANTY.

The use of third-party rechargeable Li-ion batteries not bearing the Nikon holographic seal could interfere with normal operation of the camera or result in the batteries overheating, igniting, rupturing, or leaking.

For more information about Nikon brand accessories, contact a local authorized Nikon dealer.

Holographic seal: Identifies this device as an authentic Nikon product.



Before Taking Important Pictures

Before taking pictures on important occasions (such as at weddings or before taking the camera on a trip), take a test shot to ensure that the camera is functioning normally. Nikon will not be held liable for damages or lost profits that may result from product malfunction.

About the Manuals

- No part of the manuals included with this product may be reproduced, transmitted, transcribed, stored in a retrieval system, or translated into any language in any form, by any means, without Nikon's prior written permission.
- Nikon reserves the right to change the specifications of the hardware and software described in these manuals at any time and without prior notice.
- Nikon will not be held liable for any damages resulting from the use of this product.
- While every effort was made to ensure that the information in these manuals is accurate and complete, we would appreciate it were you to bring any errors or omissions to the attention of the Nikon representative in your area (address provided separately).

Notice Concerning Prohibition of Copying or Reproduction

Note that simply being in possession of material that was digitally copied or reproduced by means of a scanner, digital camera or other device may be punishable by law.

• Items prohibited by law from being copied or reproduced

Do not copy or reproduce paper money, coins, securities, government bonds or local government bonds, even if such copies or reproductions are stamped "Sample." The copying or reproduction of paper money, coins, or securities which are circulated in a foreign country is prohibited. Unless the prior permission of the government was obtained, the copying or reproduction of unused postage stamps or post cards issued by the government is prohibited.

The copying or reproduction of stamps issued by the government and of certified documents stipulated by law is prohibited.

• Cautions on certain copies and reproductions

The government has issued cautions on copies or reproductions of securities issued by private companies (shares, bills, checks, gift certificates, etc.), commuter passes, or coupon tickets, except when a minimum of necessary copies are to be provided for business use by a company. Also, do not copy or reproduce passports issued by the government, licenses issued by public agencies and private groups, ID cards and tickets, such as passes and meal coupons.

• Comply with copyright notices

The copying or reproduction of copyrighted creative works such as books, music, paintings, woodcut prints, maps, drawings, movies, and photographs is governed by national and international copyright laws. Do not use this product for the purpose of making illegal copies or to infringe copyright laws.

Disposing of Data Storage Devices



Please note that deleting images or formatting data storage devices such as memory cards or built-in camera memory does not completely erase the original image data. Deleted files can sometimes be recovered from discarded storage devices using commercially available software, potentially resulting in the malicious use of personal image data. Ensuring the privacy of such data is the user's responsibility.

Before discarding a data storage device or transferring ownership to another person, erase all data using commercial deletion software, or format the device and then completely refill it with images containing no private information (for example, pictures of empty sky). Be sure to also replace any pictures selected for the **Select an image** option in the **Welcome screen** setting (📖 159). Care should be taken to avoid injury or damage to property when physically destroying data storage devices.

Parts of the Camera

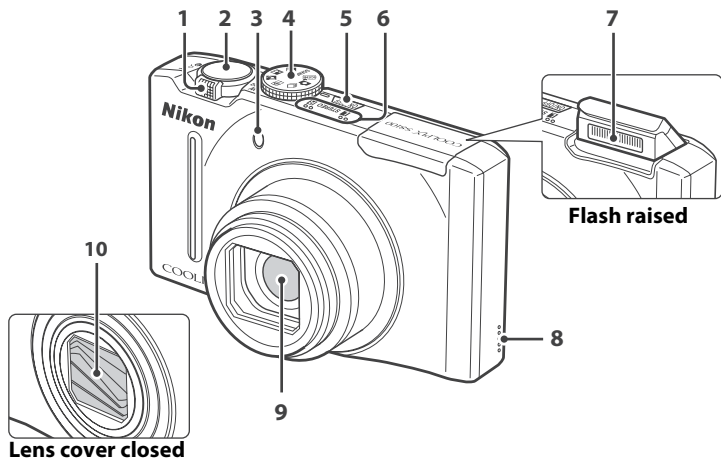
The Camera Body



1	Zoom control.....25
	W : wide.....25
	T : tele.....25
	 : thumbnail playback.....85, 87
	 : playback zoom.....88
	 : help.....55
2	Shutter-release button.....11, 26
3	Self-timer lamp.....33
	AF-assist illuminator.....169
4	Mode dial.....42

5	Power switch/power-on lamp17, 171
6	Microphone (stereo).....117, 129
7	Flash.....30
8	Speaker.....118, 140
9	Lens.....182, 198
10	Lens cover

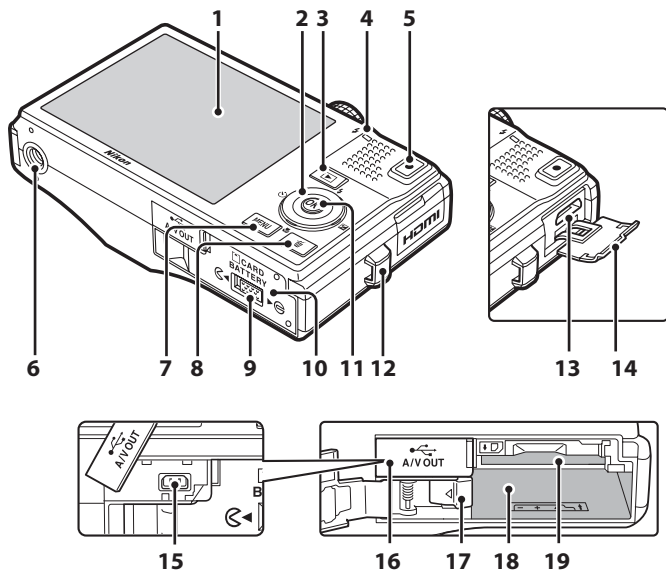

- | | | | |
|-----------|---|-----------|--|
| 1 | Monitor6, 23 | 11 | OK (apply selection) button.....9 |
| 2 | Rotary multi selector.....9 | 12 | Eyelet for camera strap.....11 |
| 3 | ▶ (playback) button.....8, 28, 80 | 13 | HDMI mini connector.....143 |
| 4 | Charge lamp15, 150
Flash lamp.....32 | 14 | HDMI connector cover143 |
| 5 | ● (movie-record) button8, 129 | 15 | USB/audio/video output connector
.....14, 143, 146, 152 |
| 6 | Tripod socket.....199 | 16 | Connector cover.....14, 143, 146, 152 |
| 7 | MENU button.....10, 43, 90, 108, 133, 158 | 17 | Battery latch12, 13 |
| 8 | 🗑️ (delete) button.....29, 118, 140 | 18 | Battery chamber.....12 |
| 9 | Cover latch.....12, 20 | 19 | Memory card slot20 |
| 10 | Battery-chamber/
memory card slot cover.....12, 20 | | |

The Monitor

The following indicators may appear in the monitor during shooting and playback (actual display varies with current camera settings).

The indicators that appear in the monitor during shooting and playback disappear after a few seconds (📖 163).

Shooting

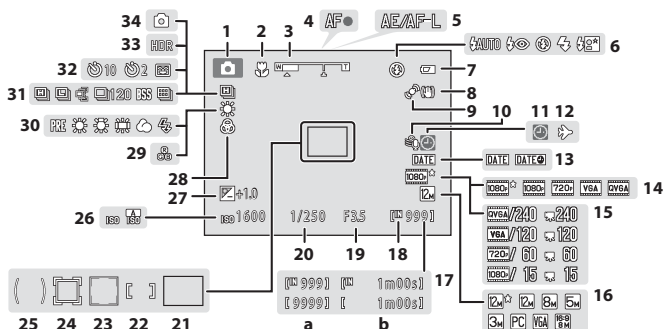

1	Shooting mode*.....	22, 55, 70, 73	18	Internal memory indicator.....	23
2	Macro mode.....	36	19	Aperture.....	26
3	Zoom indicator.....	25, 36	20	Shutter speed.....	26
4	Focus indicator.....	26	21	Focus area (auto).....	26, 50
5	AE/AF-L indicator.....	69	22	Focus area (for manual or center).....	50
6	Flash mode.....	30	23	Focus area (face detection).....	26, 50
7	Battery level indicator.....	22	24	Focus area (subject tracking mode).....	70
8	Vibration reduction icon.....	23, 166	25	Center-weighted metering area.....	48
9	Motion detection icon.....	168	26	ISO sensitivity.....	31, 49
10	Wind noise reduction.....	136	27	Exposure compensation value.....	40, 41
11	"Date not set" indicator.....	160, 186	28	Vividness.....	40
12	Travel destination icon.....	160	29	Hue.....	40
13	Date imprint.....	165	30	White balance.....	46
14	Movie type.....	134	31	Continuous shooting mode.....	73
15	HS movie type.....	139	32	Self-timer/smiley timer.....	33, 34
16	Image mode.....	44	33	Backlighting (HDR).....	60
17	(a) Number of exposures remaining (still images).....	22	34	Still image capture (movie recording).....	131
	(b) Movie length.....	129, 135			

* The icon displayed varies with the shooting mode.

Playback

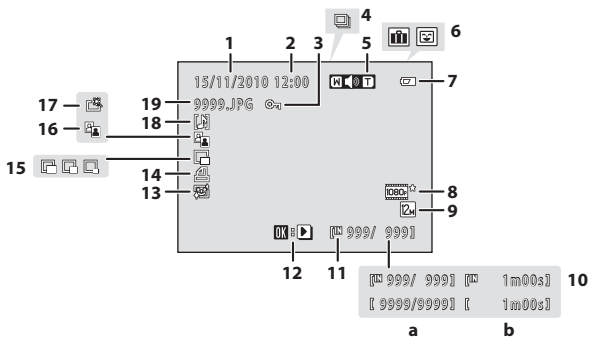







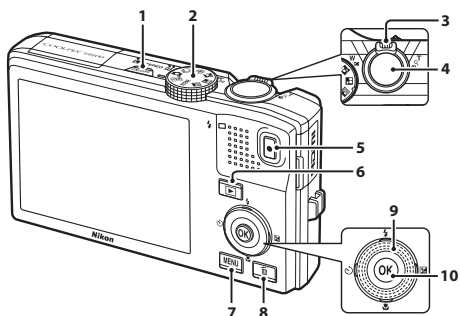

1	Date of recording	18	11	Internal memory indicator	28
2	Time of recording	18	12	Sequence playback guide	83
3	Protect icon	114		Movie playback guide	140
4	Sequence display	83, 86	13	Skin softening icon	126
5	Volume indicator	118, 140	14	Print set icon	109
6	Album icon in favorite pictures mode ¹	94	15	Small picture icon	127
	Category icon in auto sort mode ¹	100	16	D-Lighting icon	125
7	Battery level indicator	22	17	Quick retouch icon	124
8	Movie type ²	134	18	Voice memo indicator	118
9	Image mode ²	44, 131	19	File number and type	185
10	(a) Current frame number/ total number of frames	28			
	(b) Movie length	140			



¹ The icon for the selected album or the selected category in auto sort mode in playback mode is displayed.

² The icon displayed varies with the setting that was set at the time of shooting.

Main Features of the Operation Controls

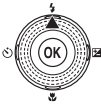
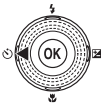
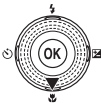
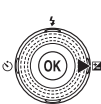

Control	Name	Function
1 	Power switch	Turns the camera on and off (17)
2 	Mode dial	Shooting mode: changes the shooting mode (42) Playback mode: switches to the shooting screen
3 	Zoom control	Shooting mode: rotate to T (Q) to zoom in; rotate to W () to zoom out (25) Playback mode: rotate to T (Q) to magnify (88); rotate to W () to display thumbnail or calendar (85, 87)
4 	Shutter-release button	Shooting mode: releases the shutter (11, 26) Playback mode: switches to the shooting screen
5 	Movie-record button	Shooting mode: starts and stops movie recording (129) Playback mode: switches to the shooting screen
6 	Playback button	Power is off: press and hold to turn on the camera in playback mode Shooting mode: plays back images (28, 80, 140) Playback mode: switches to the shooting screen
7 	MENU button	Turns the menu on and off (10, 43, 90, 108, 133, or 158)

	Control	Name	Function			
8		Delete button	Shooting mode: deletes the last image captured (📖 29)			
			Playback mode: deletes images or voice memo (📖 29, 118, or 140)			
9		Rotary multi selector (up)	Shooting mode: displays the ⚡ (flash mode) menu (📖 30)			
			Playback mode: selects the previous image			
				During menu display: moves the highlight up		
		Rotary multi selector (left)	Shooting mode: displays the ⌚ (self-timer)/smile timer menu (📖 33, 34)			
			Playback mode: selects the previous image			
				During menu display: moves the highlight left/ returns to the previous screen		
		Rotary multi selector (down)	Shooting mode: displays the 📷 (macro mode) menu (📖 36)			
			Playback mode: selects the next image			
				During menu display: moves the highlight down		
		Rotary multi selector (right)	Shooting mode: displays creative slider (📖 38), displays the 📷 (exposure compensation) setting screen (📖 41)			
Playback mode: selects the next image						
			During menu display: moves the highlight right/ proceeds to next screen (applies selection)			
		Rotary multi selector (rotate)	Playback mode: selects the previous or next image			
			During menu display: moves the highlight			
10		Apply selection button	Playback mode (full-frame playback): displays histogram and shooting information (except for movies)/returns to full-frame playback (📖 82), displays individual images of a sequence (📖 83), plays back movies (📖 140)			
						Playback mode (Zoom in/thumbnailedisplay): switches to full-frame playback (📖 85, 88)
						During menu display: applies selection (goes to next screen)

Using Camera Menus

Press the **MENU** button (📖 8) to display the menu for the selected mode.

Use the rotary multi selector (📖 9) to navigate the menus.

Tab for the menus available in the current shooting mode/
tab for playback mode menu

Tab for movie menu (during shooting mode)/playback menu (during playback mode)

Tab for displaying the setup menu

△ is displayed when previous menu items are available

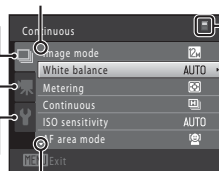

Displayed when the menu contains two or more pages

Displayed when there are one or more menu items to follow

1 Press the **MENU** button.

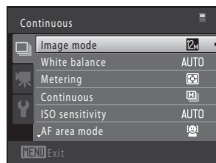
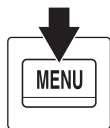

2 Press the rotary multi selector ▲ or ▼ to choose an item, and then press ► or the **OK** button.

Items can also be chosen by rotating the rotary multi selector (📖 9).

To change tabs, press ◀ (📖 11).

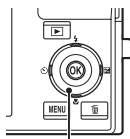

Rotary multi selector

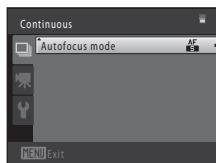

3 Press ▲ or ▼ to choose an item and press the **OK** button.

The setting is applied.

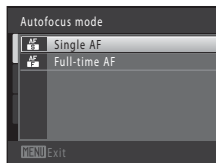

4 When setting is finished, press the **MENU** button.

The camera exits the menu display.

Switching Between Tabs

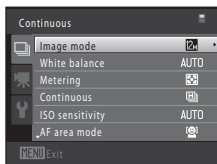

Press the rotary multi selector ◀ to highlight the tab



Press the rotary multi selector ▲ or ▼ to select a tab, and press either the OK button or ▶

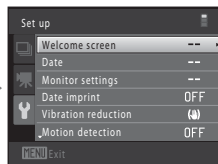

The selected menu is displayed

The Shutter-release Button

The camera features a two-stage shutter-release button. To set focus and exposure, press the shutter-release button halfway, stopping when you feel resistance. When the shutter-release button is pressed halfway, focus and exposure (shutter speed and aperture value) are set. Focus and exposure remain locked while the shutter-release button is pressed halfway.

While the shutter-release button is held in this position, release the shutter and take a picture by pressing the shutter-release button the rest of the way down. Do not use force when pressing the shutter-release button, as this may result in camera shake and blurred images.



Press halfway to set focus and exposure



Press the rest of the way down to take a picture

Attaching the Camera Strap

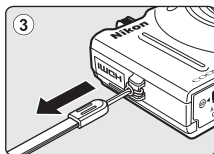
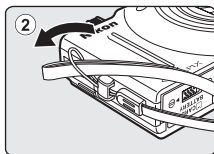
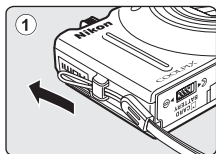

Inserting the Battery

Insert a Rechargeable Li-ion Battery EN-EL12 (supplied) into the camera.

- Charge the battery before the first use or when the battery is running low (📖 14).

- 1 Open the battery-chamber/memory card slot cover.

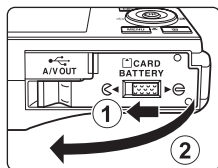

- 2 Insert the supplied battery.

Use the edge of the battery to push the orange battery latch in the direction indicated by the arrow (1) and fully insert the battery (2).

When the battery is fully inserted, the battery latch will lock it in place.

Battery chamber

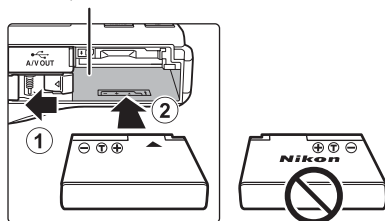

✓ Inserting the Battery

Inserting the battery upside down or backwards could damage the camera. Be sure to check that the battery is in the correct orientation.

- 3 Close the battery-chamber/memory card slot cover.

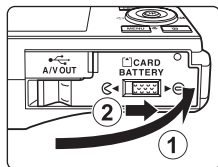

Removing the Battery

Turn the camera off (📖 17) and be sure that the power-on lamp and the monitor have turned off before opening the battery-chamber/memory card slot cover.

To eject the battery, open the battery-chamber/memory card slot cover and slide the orange battery latch in the direction indicated by the arrow (①). The battery can then be removed by hand (②).

- The battery or memory card may be hot immediately after using the camera. Observe caution when removing the battery or memory card.

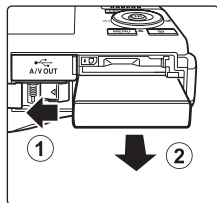

✓ Notes on the Battery

- Be sure to read and follow the warnings for the battery on page iii and the section, “The Battery” (📖 181), before use.
- If the battery will not be used for an extended period, recharge it at least once every six months and run it flat before returning it to storage.

Charging the Battery

Charge the supplied Rechargeable Li-ion Battery EN-EL12 inserted into the camera, by connecting the supplied Charging AC Adapter EH-68P to the camera via the supplied USB Cable UC-E6, and then plugging the Charging AC Adapter into an electrical outlet.

First Steps

1 Prepare the Charging AC Adapter EH-68P.

If a plug adapter* is included, attach the plug adapter to the plug on the Charging AC Adapter. Push the plug adapter firmly until it is securely held in place. Once the two are connected, attempting to forcibly remove the plug adapter could damage the product.

* The shape of the plug adapter varies according to the country or region in which the camera was purchased.

For Customers in Argentina

If the camera was purchased in Argentina, the shape of the Charging AC Adapter EH-68P (AR) differs from that supplied in other countries, and a plug adapter is not included. Proceed to step 2.

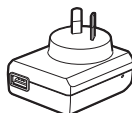
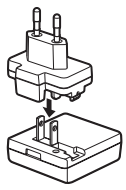
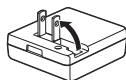

EH-68P (AR)

2 Insert the battery (📖 12).

Do not turn the camera on.

3 Use the supplied USB cable to connect the Charging AC Adapter to the camera.

Be sure that connectors are properly oriented. Do not attempt to insert connectors at an angle, and do not use force when connecting or disconnecting the USB cable.

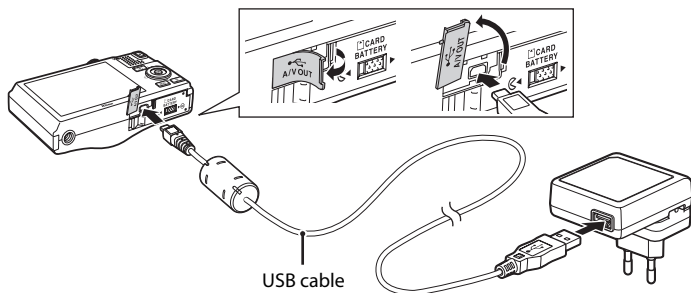

USB cable

4 Plug the Charging AC Adapter into an electrical outlet.

The charge lamp slowly blinks green to indicate that the battery is charging.

About three hours and 50 minutes are required to charge a fully exhausted battery.

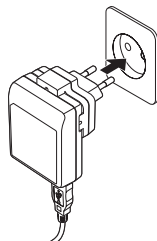

The following chart explains charge lamp status when the camera is plugged into the electrical outlet.

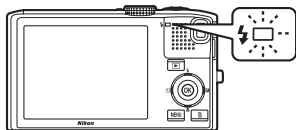

Charge lamp	Description
Blinks slowly (green)	Battery charging.
Off	Battery not charging. When charging is complete, the charge lamp stops blinking green and turns off.
Flickers (green)	<ul style="list-style-type: none"> The ambient temperature is not suited to charging. Charge the battery indoors with an ambient temperature of 5 °C to 35 °C (41 °F to 95 °F). The USB cable or Charging AC Adapter is not properly connected, or there is a problem with the battery. Disconnect the USB cable or unplug the Charging AC Adapter and correctly connect it again, or change the battery.

5 Disconnect the Charging AC Adapter from the electrical outlet and then disconnect the USB cable.

Charging the Battery

Notes on Charging AC Adapter

- The Charging AC Adapter EH-68P is for use only with compatible devices. Do not use with another make or model of device.
- Be sure to read and follow the warnings for the Charging AC Adapter on page iii and the section, “The Battery” (📖 181), before use.
- The EH-68P is compatible with AC 100-240 V, 50/60 Hz electrical outlets. When using in other countries, use a plug adapter (commercially available) as necessary. For more information about plug adapters, consult your travel agency.
- The Charging AC Adapter EH-68P is for charging the battery inserted into the camera. When the camera is connected to an electrical outlet with the Charging AC Adapter, the camera cannot be turned on.
- Do not, under any circumstances, use another make or model of USB-AC adapter other than Charging AC Adapter EH-68P. Failure to observe this precaution could result in overheating or in damage to the camera.

AC Power Source

- If the AC Adapter EH-62F (available separately; 📖 183) is used, power is supplied to the camera from an electrical outlet and taking pictures and playing back images are available with this camera.
- Do not, under any circumstances, use another make or model of AC adapter other than EH-62F. Failure to observe this precaution could result in overheating or in damage to the camera.



Charging Using Computer or Battery Charger

- Connecting the COOLPIX S8100 to a computer also charges the Rechargeable Li-ion Battery EN-EL12 (📖 145, 174).
- The EN-EL12 can be charged without using the camera by using the Battery Charger MH-65 (available separately; 📖 183).

Turning On and Off the Camera

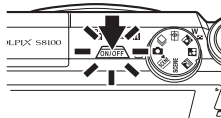
Press the power switch to turn on the camera. The power-on lamp (green) will light, and then the monitor will turn on (the power-on lamp turns off when the monitor turns on). To turn off the camera, press the power switch again. When the camera is turned off, the power-on lamp and the monitor will turn off.







- If the camera is turned off, hold down the  button to turn the camera on in playback mode ( 28).

Power Saving Function (Auto Off)

If no operations are performed for a while, the monitor will turn off, the camera will enter standby mode, and the power-on lamp will blink. If no operations are performed for another three minutes, the camera will turn off automatically.

When the power-on lamp is blinking, the following operations will turn the monitor back on.

- Pressing the power switch, shutter-release button,  button, or  (movie-record) button
- Rotating the mode dial
- In shooting or playback mode, the camera will enter standby mode in about one minute (default setting).
- The time allowed to elapse before the camera enters standby mode can be changed from the **Auto off** option ( 171) in the setup menu ( 157).

Setting Display Language, Date, and Time

When the first time the camera is turned on, the language-selection screen and the date and time setting screen for the camera clock are displayed.

1 Press the power switch to turn on the camera.

The power-on lamp (green) will light, and then the monitor will turn on (the power-on lamp turns off when the monitor turns on).

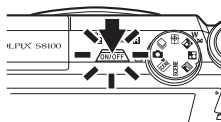

2 Use the rotary multi selector to choose the desired language and press the **OK** button.

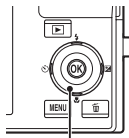

Rotary multi selector



3 Press **▲** or **▼** to choose **Yes** and press the **OK** button.

To cancel setting the date and time, press **▲** or **▼** to select **No**.

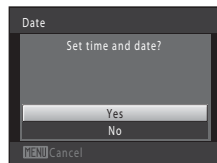

4 Press **◀** or **▶** to choose your home time zone (📖 162) and press the **OK** button.

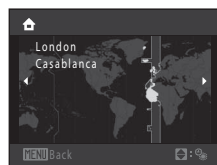

Daylight Saving Time

If daylight saving time is in effect, press **▲** to enable the daylight saving time function while setting the region in step 4.

When the daylight saving time function is enabled,  is displayed at the top of the monitor. Press **▼** to disable the daylight saving time function.

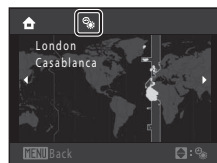

5 Edit the date and time.

Select an item: Press ► or ◀ (changes between **D**, **M**, **Y**, hour, minute, **DMY** (the order in which the day, month, and year are displayed)).

Edit the highlighted item: Rotate the rotary multi selector, or press ▲ or ▼.

Day, month, and year can be displayed in DMY, YMD, or MDY order.

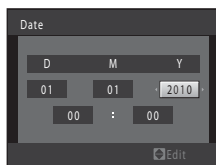

6 Finally, choose **DMY** (the order in which the day, month, and year are displayed) and press the **OK** button or press ►.

The clock starts. The lens extends and the screen used for taking pictures is displayed.

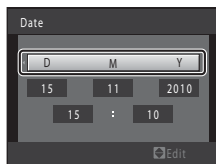

Date Imprint and Changing the Date and Time

- To imprint the date on images while taking pictures, enable date imprint from the **Date imprint** option (📖 165) in the setup menu (📖 157) after the date and time have been set.
- To change the camera's internal time setting, select **Date** from the **Date** option (📖 160) in the setup menu (📖 157) and follow the procedure described from step 5.
- To change the time zone and daylight saving time settings, select **Time zone** from the **Date** option (📖 160) in the setup menu.

Inserting Memory Cards

Image, sound, and movie files are saved in the camera's internal memory (approximately 102 MB) or on removable Secure Digital (SD) memory cards (commercially available;  184).

If a memory card is inserted in the camera, data are automatically saved on the memory card and data saved to the memory card can be played back, deleted, or transferred. Remove the memory card to save data in the internal memory, or play back, delete, or transfer data from the internal memory.

- 1 Be sure that the power-on lamp and the monitor are off and open the battery-chamber/memory card slot cover.

Be sure to turn off the camera before opening the cover.

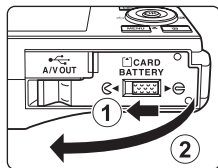

- 2 Insert the memory card.

Slide the memory card in until it clicks into place.

Inserting Memory Cards

Inserting the memory card upside down or backwards could damage the camera or the memory card. Be sure to check that the memory card is in the correct orientation.

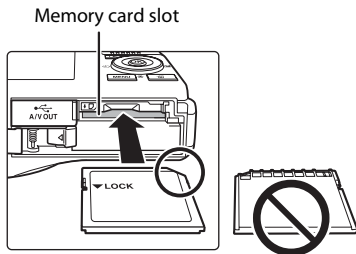

- 3 Close the battery-chamber/memory card slot cover.

Removing Memory Cards

Turn the camera off and be sure that the power-on lamp and the monitor have turned off before opening the battery-chamber/memory card slot cover.

Press the card in (1) to partially eject the card, then remove the card by hand while being careful not to remove the card at an angle (2).

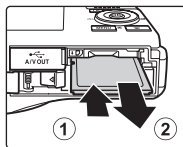

- The battery or memory card may be hot immediately after using the camera. Observe caution when removing the battery or memory card.

✓ Formatting Memory Cards

If the message on the right is displayed when the camera is turned on, the memory card must be formatted before use (📖 172). Note that **formatting permanently deletes all images and other data on the memory card**. Be sure to make copies of any images you wish to keep before formatting the memory card.

When formatting the memory card, use the rotary multi-selector to choose **Yes** and press the **OK** button. The confirmation dialog will be displayed. To start formatting, choose **Format** and press the **OK** button.

- Do not turn the camera off or open the battery-chamber/memory card slot cover until formatting is complete.
- Be sure to use this camera to format memory cards previously used in other devices the first time they are inserted into the COOLPIX S8100 (📖 172).

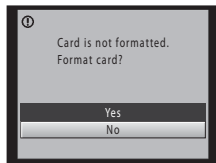

✓ Note on the Write Protect Switch

When memory card switch is in the lock position, data cannot be written to, or deleted from, the memory card. If the switch is in the lock position, unlock it by sliding the switch to the write position to save or delete images, or to format the memory card.

Write protect switch

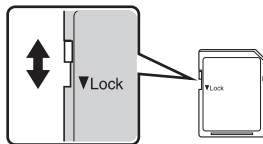



✓ Notes on Memory Cards



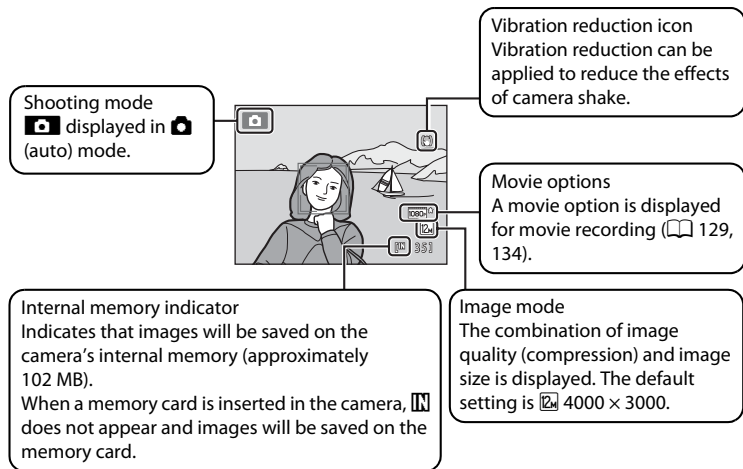

- Use only Secure Digital memory cards.
- Do not perform the following during formatting, while data is being written to or deleted from the memory card, or during data transfer to a computer. Failure to observe this precaution could result in the loss of data or in damage to the camera or memory card:
 - Remove the battery or memory card
 - Turn off the camera
 - Disconnect the AC adapter
- Do not format the memory card using a computer.
- Do not disassemble or modify.
- Do not drop, bend, or expose to water or strong physical shock.
- Do not touch the metal terminals with your fingers or metal objects.
- Do not affix labels or stickers to the memory card.
- Do not leave in direct sunlight, closed vehicles, or areas exposed to high temperatures.
- Do not expose to humidity, dust, or corrosive gases.

Indicators Displayed in (Auto) Mode





- The indicators and photo info displayed during shooting and playback will turn off after a few seconds ( 163).
- When the monitor has turned off in standby mode to save power (the power-on lamp is blinking) ( 171), press the following buttons to turn it back on.
 → Power switch or Shutter-release button

Functions Available in (Auto) Mode

- The flash mode ( 30) can be adjusted, the self-timer ( 33) and macro mode ( 36) can be applied.
- Brightness (exposure compensation), vividness, and hue can be adjusted with the creative slider ( 37).
- Press the **MENU** button to specify settings for all shooting menu items ( 43) according to shooting conditions. The combination of image quality (compression) and image size can be set by using the **Image mode** option in the shooting menu.

Vibration Reduction

- See **Vibration reduction** ( 166) in the setup menu ( 157) for more information.
- Set **Vibration reduction** to **Off** when using a tripod to stabilize the camera during shooting.

Step 2 Frame a Picture

1 Ready the camera.

Hold the camera steadily in both hands. Do not hold the flash down with your fingers or other objects.

Keep fingers, hair and other objects away from the lens, flash, AF assist-illuminator and microphone.

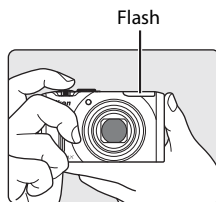

When taking pictures in portrait ("tall") orientation, turn the camera so that the flash is above the lens.

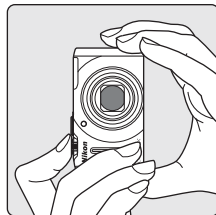

2 Frame the picture.

When the camera detects a human face, that face is framed by a yellow double border (focus area) (default setting).

Up to 12 faces can be detected. When the camera detects more than one face, the face closest to the camera is framed by a double border and the others by single borders.

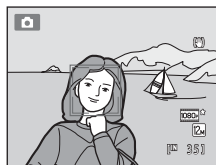

When shooting non-human subjects or when no faces are detected, the focus area is not displayed. Position the main subject near the center of the frame.

Using the Zoom

Use the zoom control to activate optical zoom. Rotate the zoom control toward **T** to zoom in, increasing the size of the subject. Rotate the zoom control toward **W** to zoom out, increasing the area visible in the frame.

- When the camera is turned on, the zoom is at the widest position.
- A zoom indicator is displayed at the top of the monitor when the zoom control is rotated.

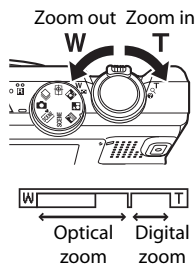

Digital Zoom

When the camera is zoomed in to the maximum optical zoom position, rotating and holding the zoom control at **T** triggers digital zoom.

Digital zoom can magnify the subject up to about 4x beyond the maximum magnification of the optical zoom.

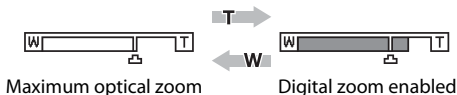



- The camera focuses at the center of the frame and the focus area is not displayed when digital zoom is in effect.

Digital Zoom and Interpolation

Unlike optical zoom, digital zoom uses a digital imaging process known as interpolation to magnify images, resulting in slight deterioration of picture quality according to the image mode (📖 44) and digital zoom magnification.

Interpolation is applied at zoom positions beyond  when taking still images.

When zoom is increased beyond the  position, interpolation is initiated and the zoom indicator turns yellow to indicate that interpolation is being applied.

The position of  moves to the right as image size decreases, allowing for confirmation of the zoom positions at which shooting without interpolation is possible at the current image mode setting.

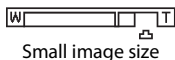

- Digital zoom can be disabled from the **Digital zoom** option (📖 169) in the setup menu (📖 157).

Step 3 Focus and Shoot

1 Press the shutter-release button halfway.

When the shutter-release button is pressed halfway (📖 11), the camera sets focus and exposure (shutter speed and aperture value). Focus and exposure remain locked while the shutter-release button is pressed halfway.

When a face is detected:

- The camera focuses on the face framed by the double border. When the subject is in focus, the double border glows green.

When a face is not detected:

- The camera has nine focus areas, and automatically selects the focus areas containing the subject closest to the camera. When the subject is in focus, the focus areas that are in focus (up to nine areas) glow green.

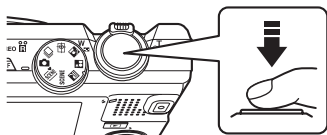

Shutter speed Aperture

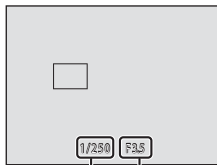

Shutter speed Aperture

The camera focuses at the center of the frame and the focus area is not displayed when digital zoom is in effect. Once focus has been acquired, the focus indicator (📖 6) glows green.

While the shutter-release button is pressed halfway, the focus area or focus indicator may blink red. This indicates that the camera is unable to focus. Modify the composition and press the shutter-release button halfway again.

If the shutter-release button is pressed halfway when the subject is dimly lit, the AF-assist illuminator (📖 169) may light or the flash (📖 4, 30) may pop up.

2 Press the shutter-release button the rest of the way down.

The shutter is released and the image will be saved to the memory card or internal memory.



✔ Note on Saving Images

While images are being saved, the number of exposures remaining will blink. **Do not open the battery-chamber/memory card slot cover** while images are being saved. Cutting power or removing the memory card in these circumstances could result in loss of data or in damage to the camera or card.

✔ Autofocus

Autofocus may not perform as expected in the following situations. In some rare cases, the subject may not be in focus despite the fact that the focus area or the focus indicator glows green:

- Subject is very dark
- Objects of sharply differing brightness are included in the scene (e.g. the sun is behind the subject and the subject is in deep shadow)
- No contrast between the subject and surroundings (e.g. when the subject is wearing a white shirt and is standing in front of a white wall)
- Subject contains objects of varying distances from the camera (such as a cage with an animal inside)
- Subjects with repeating patterns (window blinds, buildings with multiple rows of similarly shaped windows, etc.)
- Subject is moving rapidly

In the situations noted above, try pressing the shutter-release button halfway to refocus several times, or focus on another subject positioned at the same distance from the camera as the actual desired subject, and use focus lock (📖 51).

✔ Note on Face Detection

See “AF Area Mode” (📖 50) or “Face Detection” (📖 52) for more information.

✔ When the Subject Is Close to the Camera

If the camera cannot focus, try shooting with macro mode (📖 36) or the **Close-up** scene mode (📖 64).

✏ Flash

- When the flash mode (📖 30) is set to **⚡AUTO** (auto) (default setting) and the subject is dimly lit, the flash pops up automatically when the shutter-release button is pressed halfway, and the flash fires when the shutter-release button is pressed the rest of the way.
- If the flash mode is set to **🔇** (off) (📖 30), the camera can shoot pictures with the flash lowered.
- Lower the flash by gently pushing it down. When not taking pictures, lower the flash.

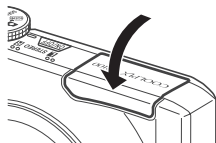
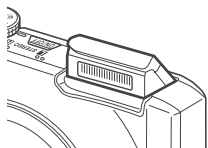







Step 4 Playing Back and Deleting Images



Playing Back Images (Playback Mode)

Press the  (playback) button.

The last image captured will be displayed in full-frame playback mode.



Rotate the rotary multi selector, or press , , , or  to view previous or next images ( 9).

To return to shooting mode, press the  button, shutter-release button, or  (movie-record) button.

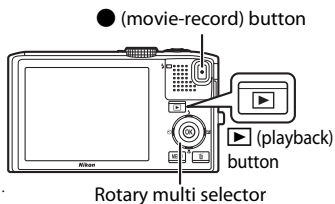
When playing back images saved in the camera's internal memory,  is displayed. When a memory card is inserted in the camera,  is not displayed and images saved on the memory card are played back.





When the Monitor Has Turned Off to Save Power

When the power-on lamp is blinking, press the power switch, shutter-release button, or  button to turn the monitor back on ( 171).

Operations Available in Playback Mode

See “More on Playback” ( 80) or “Editing Images” ( 122) for more information.

Displaying Shooting Information

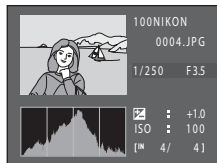

Press the  button in full-frame playback mode to display the highlight, histogram, and shooting information ( 82). Press the  button again to return to full-frame playback mode.



Pressing the Button to Turn On the Camera

When the camera is off, holding down the  button will turn the camera on in playback mode. The lens will not extend.



Viewing Images

- When images in which a face was detected during shooting ( 52) are displayed in full-frame playback mode, depending upon the orientation of the detected face, the images may be automatically rotated for playback display except images captured with continuous shooting mode ( 73).
- When images captured with the continuous shooting feature are displayed, each series of images is treated as a group, and only the group's “key picture” is displayed (sequence display →  83).

Deleting Unwanted Images

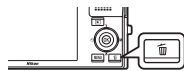
- 1 Press the  button to delete the image currently displayed in the monitor.
To exit without deleting, press the rotary multi selector .



- 2 Press the rotary multi selector  or  to choose the desired deletion method and press the  button.



Current image: Only the current image or voice memo ( 118) is deleted.

Erase selected images: Multiple images can be selected and deleted.

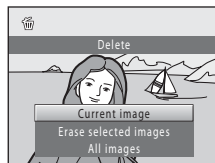

→ “Operating the Erase Selected Images Screen”

All images: All images are deleted.







- 3 Press  or  to choose **Yes** and press the  button.

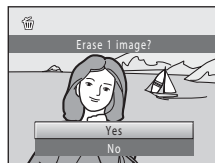

Deleted images cannot be recovered.

To cancel, press  or  to select **No** and press the  button.





Operating the Erase Selected Images Screen

- 1 Press the rotary multi selector  or  to choose an image to be deleted and press  to add  to the image and mark it for deletion.

To undo the selection, press  to remove .



Rotate the zoom control ( 4) to **T** () to switch back to full-frame playback or **W** () to display thumbnails.



- 2 Add  to all desired images and then press the  button to confirm the selection.

A confirmation dialog is displayed. Follow the instructions displayed in the monitor.

Notes on Deletion

- Deleted images cannot be restored. Transfer important images to a computer before deleting them.
- Protected images cannot be deleted ( 114).
- Deleting images captured with the continuous shooting feature → “Deleting Images in a Sequence” ( 84)

Deleting the Last Image Captured While in Shooting Mode

In shooting mode, press the  button to delete the last image captured.

Using the Flash

The flash mode can be set to match the shooting conditions.

- When **ISO sensitivity** is set to **Auto**, the flash has a range of 0.5-4.0 m (1 ft. 8 in.-13 ft.) at the maximum wide-angle zoom position and a range of 0.5-2.5 m (1 ft. 8 in.-8 ft. 2 in.) at the maximum telephoto zoom position.

Auto

Flash fires automatically when lighting is dim.

Auto with red-eye reduction

Reduce “red-eye” in portraits (📖 32).

Off

Flash will not fire even when lighting is dim.





Fill flash

Flash fires whenever a picture is taken. Use to “fill-in” (illuminate) shadows and backlit subjects.

Slow sync

Auto flash mode is combined with slow shutter speed. Suited to evening and night portraits that include background scenery. Flash illuminates main subject; slow shutter speeds are used to capture background at night or under dim lighting.

Raising and Lowering the Flash

- Auto flash ( auto,  auto with red-eye reduction, or  slow sync): if the subject is dimly lit, the flash automatically pops up when the shutter-release button is pressed halfway. The camera determines whether or not the flash pops up based on the brightness of the subject and the settings used during shooting.
-  off: The flash does not pop up, even when the shutter-release button is pressed halfway. The camera can shoot pictures with the flash lowered.
-  fill flash: The flash pops up when the shutter-release button is pressed halfway during shooting.

When not taking pictures, lower the flash.

Lower the flash by gently pushing it down, being careful not to pinch fingers or other objects.

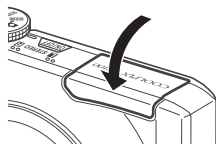
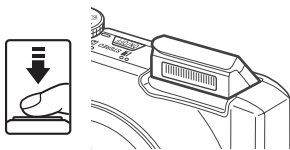

Setting the Flash Mode

- 1 Press the rotary multi selector  (flash mode).

The flash mode menu is displayed.

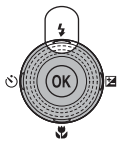

- 2 Use the rotary multi selector to choose the desired mode and press the  button.

The icon for the selected flash mode is displayed.

When  AUTO (auto) is applied,  AUTO is only displayed for a few seconds, regardless of **Photo info** settings (📖 164).

If a setting is not applied by pressing the  button within a few seconds, the selection will be canceled.

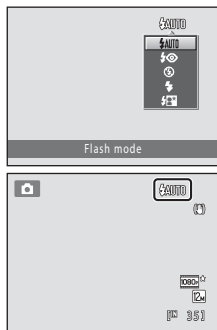

Notes on Shooting When the Flash Is Disabled () or Lighting Is Dim

- Use of a tripod is recommended to stabilize the camera during shooting. Set **Vibration reduction** (📖 166) to **Off** in setup menu (📖 157) when using a tripod to stabilize the camera.
- **ISO** may be displayed in the shooting screen. When **ISO** is displayed, ISO sensitivity is automatically increased.
- The noise reduction function may be activated with some shooting conditions such as dim lighting. More time than usual is required to save images to which noise reduction is applied.

Note on the Flash

When using the flash, reflections from dust particles in the air may appear as bright spots in images. To reduce these reflections, set the flash to  (off).

Using the Flash

The Flash Lamp

The flash lamp indicates flash status when the shutter-release button is pressed halfway.

















- On: Flash will fire when picture is taken.
- Blinks: Flash charging. Wait a few seconds and try again.
- Off: Flash will not fire when picture is taken.

If the battery is low, the monitor display will turn off, and remain off, until the flash is fully charged.



The Flash Mode Setting

The default flash mode setting with shooting mode ( 42).

-  (auto):  AUTO (auto)
-  (scene auto selector):  AUTO (auto). The camera selects the optimum flash mode setting for the scene mode it has selected.
- SCENE: varies with the selected scene mode ( 61–67)
-  (night landscape): fixed at  (off)
-  (night portrait): fixed at  (auto with red-eye reduction)
-  (backlighting): fixed at  (fill flash) (when **HDR** is Off), fixed at  (off) (when **HDR** is On) ( 60)
-  (subject tracking):  AUTO (auto)
-  (continuous): fixed at  (off)

The flash cannot be used simultaneously with certain functions. See “Camera Settings that Cannot Be Applied Simultaneously” ( 78) for more information.

The flash mode setting applied in  (auto) mode is saved in the camera’s memory even after the camera is turned off.

Red-eye Reduction

This camera uses advanced red-eye reduction (In-Camera Red-Eye Fix). Pre-flashes are fired repeatedly at low intensity before the main flash, reducing the red-eye effect. Additionally, if the camera detects red eye while saving an image, the affected area will be processed to reduce red-eye before the image is saved.

Note the followings when shooting.

- Because pre-flashes are fired, there is a slight lag between when the shutter-release button is pressed and when the shutter is released.
- More time than usual is required to save images.
- Red-eye reduction may not produce the desired results in some situations.
- In extremely rare instances, areas not subject to red-eye may be affected by red-eye reduction processing; in these cases, choose another flash mode and try again.

Taking Pictures with the Self-timer

The self-timer is useful for self-portraits or reducing the effects of camera shake that occur when the shutter-release button is pressed. When using the self-timer, use of a tripod is recommended. Set **Vibration reduction** (📖 166) to **Off** in the setup menu (📖 157) when using a tripod to stabilize the camera during shooting.

1 Press the rotary multi selector (self-timer).

The self-timer menu is displayed.

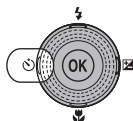

2 Use the rotary multi selector to choose **10s** or **2s** and press the button.

10s (ten seconds): Use on important occasions, such as weddings.

2s (two seconds): Use to prevent camera shake.

When  is selected, the camera uses face detection to detect a human face, and then automatically releases the shutter when a smile is detected (📖 34).

The mode selected for self-timer is displayed.

If a setting is not applied by pressing the  button within a few seconds, the selection will be canceled.

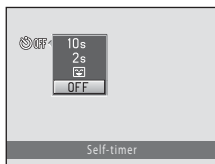

3 Frame the picture and press the shutter-release button halfway.

Focus and exposure will be set.

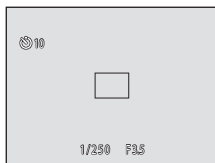

4 Press the shutter-release button the rest of the way down.

The self-timer starts, and the number of seconds remaining before the shutter is released is displayed in the monitor. The self-timer lamp blinks while the timer is counting down. About one second before the shutter is released, the lamp stops blinking and glows steadily.

When the shutter is released, the self-timer will be set to **OFF**.

To stop the timer before a picture is taken, press the shutter-release button again.

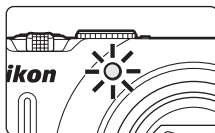
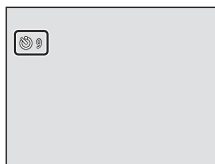

Taking Pictures with the Smile Timer

The camera uses face detection to detect human faces, and then automatically releases the shutter when a smile is detected. The skin softening option can be used to smooth skin tones of human faces.

This feature can be used when shooting mode (📖 42) is set to 📷 (auto) mode or the 🌙 (night portrait) or **Portrait** scene mode (📖 55).

1 Press the rotary multi selector 🔄 (self-timer).

The self-timer menu is displayed.

To adjust settings for flash mode, creative slider, exposure compensation, or items in the shooting menu, adjust the settings before pressing 🔄.

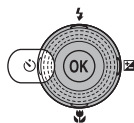

2 Use the rotary multi selector to choose 📷 (smile timer) and press the OK button.

If a setting is not applied by pressing the OK button within a few seconds, the selection will be canceled.



3 Frame a picture.

Point the camera at the subject.

When the camera detects a human face, that face is framed by a double border (focus area).

Up to three faces can be detected. When the camera detects more than one face, the double border (focus area) is displayed around the face closest to the center of the frame, and single borders around the others.

When more than one face is detected, press the OK button and select the face to be focused on. Press the rotary multi selector ◀ or ▶ to choose the face to be focused on, and press the OK button.

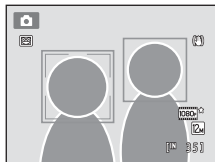

4 Press the shutter-release button all the way.

Smile detection begins, and if the camera detects that the face framed by the double border is smiling, the double border turns green and the shutter is automatically released.

Each time the shutter is released, the camera repeats automatic shooting by face detection and smile detection.

5 Press the shutter-release button all the way when shooting is complete.

Automatic shooting ends.

Shooting also ends in the following situations.

- When 12 pictures have been taken
- If five minutes pass after pressing the shutter-release button in step 4 without a smile being detected

Notes on the Smile Timer

- Digital zoom is not available.
- Under some shooting conditions, the camera may be unable to detect faces or detect smiles.
- See “Notes on Face Detection” (📖 53) for more information.
- This function cannot be used simultaneously with certain functions. See “Camera Settings that Cannot Be Applied Simultaneously” (📖 78) for more information.

Notes on Skin Softening

- The camera softens skin tones (in up to three faces) by applying the skin softening function before saving images. Therefore, more time than usual is required to save images.
- In some shooting conditions, facial skin tones may not be smoothed or parts other than face may be modified though the camera detects a face.
- The skin softening level cannot be adjusted.
- Skin softening can also be applied on saved images (📖 126).

How the Self-timer Lamp Functions When Using Smile Timer

If the camera detects a face after pressing the shutter-release button in step 4, the self-timer lamp blinks, and turns off just before the shutter is released.

More Information

See “Autofocus” (📖 27) for more information.

Macro Mode

Macro mode is used for taking pictures of objects as close as 1 cm (0.4 in.). Note that the flash may be unable to light the entire subject at distances of less than 50 cm (1 ft. 8 in.).

- 1 Press the rotary multi selector  (macro mode).

The macro mode menu is displayed.



- 2 Use the rotary multi selector to choose **ON** and press the  button.

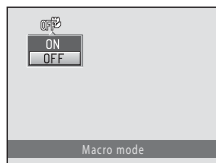

The macro mode icon () is displayed.

If a setting is not applied by pressing the  button within a few seconds, the selection will be canceled.





- 3 Rotate the zoom control to frame the picture.

The closest distance at which the camera can focus varies depending on the zoom position.

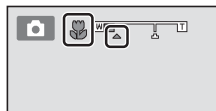
When the zoom is at a position where  and the zoom indicator glow green (to the left of ) , the camera can focus on subjects as close as 2 cm (0.8 in.) from the lens. At the maximum wide-angle position, the camera can focus on subjects as close as 1 cm (0.4 in.) from the lens.





Autofocus

When using  (auto) mode, if **Autofocus mode** ( 54) is set to **Full-time AF**, the camera focuses continuously until the shutter-release button is pressed halfway to lock the focus. Therefore, the sound of lens drive movement can be heard.

When using other shooting modes, **Full-time AF** is turned on automatically when macro mode is turned on.

The Macro Mode Setting

 (auto) mode and continuous shooting mode share the same macro mode setting. When using  (auto) mode or continuous shooting mode, the macro mode setting is saved in the camera's memory even if the camera is turned off.

Adjusting Brightness (Exposure Compensation), Vividness, and Hue

Brightness (exposure compensation), vividness, and hue can be adjusted for taking pictures by pressing the rotary multi selector ► (📷). Items that can be set vary by the shooting mode.

When Using 📷 (Auto) Mode (📖 22) and Continuous Shooting Mode (📖 73)

Brightness (exposure compensation), vividness, and hue can be adjusted with the creative slider.

📷 Brightness (Exp. +/-)

Use to brighten or darken the overall image.

📷 Vividness

Vividness adjustment is used to adjust the vividness of the entire image.

📷 Hue

Hue adjustment is used to adjust the hue of the entire image.

See “Operating the Creative Slider” (📖 38) for more information.

When Using Scene Mode (📖 55) and Subject Tracking Mode (📖 70)



Brightness (exposure compensation) can be adjusted.

📷 Exposure compensation

Use to brighten or darken the overall image.

See “Adjusting Exposure Compensation” (📖 41) for more information.

Operating the Creative Slider



When using  (auto) mode and  (continuous) mode, use the creative slider to adjust brightness (exposure compensation), vividness, and hue for taking pictures.

1 Press the rotary multi selector .

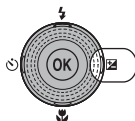
The creative slider screen is displayed.





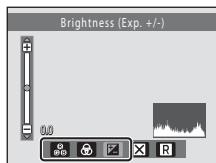

2 Press the rotary multi selector or to choose , , or .

The screen for adjusting  brightness (exposure compensation),  vividness, and  hue is displayed.





3 Adjust the brightness, vividness, or hue.

The rotary multi selector is used as follows.

-  : The slider moves. The effect can be adjusted while confirming the results in the monitor. The effect can also be adjusted by rotating the rotary multi selector.
-  : Switches between brightness (exposure compensation), vividness, and hue.

For more information on each item, see the following.

- “Adjusting Brightness (Exposure Compensation)” (📖 40)
- “Adjusting Vividness (Saturation Adjustment)” (📖 40)
- “Adjusting Hue (White Balance Adjustment)” (📖 40)

To turn off the effects of the creative slider, press  or  to choose **R**, and press the .

Slider

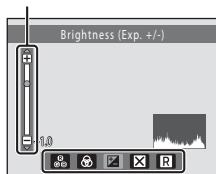

Adjusting Brightness (Exposure Compensation)

Adjust the overall brightness of the image.

- To make the subject brighter, move the slider toward “+”.
- To make the subject darker, move the slider toward “-”.

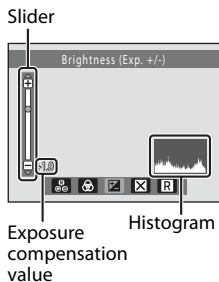

Using the Histogram

A histogram is a graph showing the distribution of tones in the image. Use as a guide when using exposure compensation and shooting without the flash.

- The horizontal axis corresponds to pixel brightness, with dark tones to the left and bright tones to the right. The vertical axis shows the number of pixels.
- Increasing exposure compensation shifts tone distribution to the right, and decreasing it shifts tone distribution to the left.

Adjusting Vividness (Saturation Adjustment)

Adjust the overall vividness of the image.

- Vividness increases as the slider is moved up.
Vividness decreases as the slider is moved down.

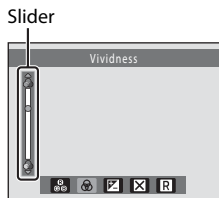

Adjusting Hue (White Balance Adjustment)

Adjust the overall hue of the image.

- The overall image becomes more reddish as the slider is moved up. The overall image becomes more bluish as the slider is moved down.

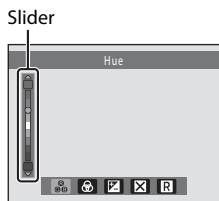

Note on White Balance Adjustment

When hue is adjusted using the creative slider, **White balance** in the shooting menu (📖 46) cannot be set.

Adjusting Exposure Compensation

When using scene mode and subject tracking mode, brightness (exposure compensation) can be adjusted for taking pictures.

- 1 Press the rotary multi selector  (exposure compensation).

The exposure compensation guide and histogram are displayed.

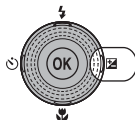



- 2 Use the rotary multi selector to select a compensation value.

To make the subject brighter, apply positive (+) exposure compensation.

To make the subject darker, apply negative (-) exposure compensation.

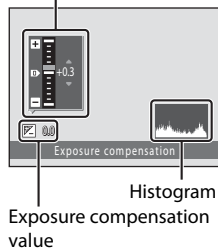
Exposure compensation guide



- 3 Press the  button to set the compensation value.

When an exposure compensation value other than **0.0** is applied, the value is displayed with the  indicator in the monitor.

- 4 Press the shutter-release button to take a picture.

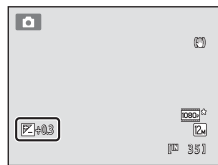

Histogram

See "Using the Histogram" (📖 40) for more information.

Selecting a Shooting Mode (Mode Dial)

Rotate the mode dial and align an icon to the mark to select one of the following shooting modes.

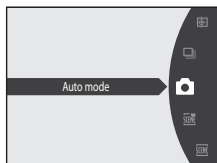
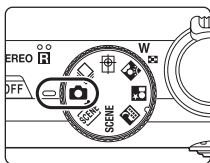

(Auto) mode (📖 22)

Pictures can be taken with an automatic, point-and-shoot mode recommended for first-time users of digital cameras. Brightness, vividness, and hue can be adjusted using the creative slider. Various settings are available in the shooting menu (📖 43).

Continuous shooting mode (📖 73)

Change settings to Continuous or BSS (best shot selector).

Subject tracking mode (📖 70)

Choose this mode to shoot moving subjects. By registering a subject, the focus area will automatically move to track and focus on the subject.

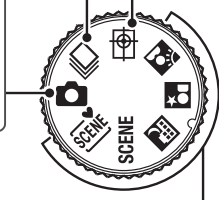

Scene mode (📖 55)

Camera settings are automatically optimized for the selected scene.

(Scene auto selector)

: By simply framing a picture, the camera automatically selects the optimum scene mode for simpler shooting.

SCENE

: Choose the desired scene from 13 different scene types, and the camera's settings are automatically optimized for the selected scene.

(Night landscape)

: Produces night landscape shots with reduced blurring and noise.

(Night portrait)

: The flash fires to light the portrait subject while preserving the atmosphere of the evening or night view.

(Backlighting)

: The flash fires when there is backlight to prevent the subject from being hidden in shadow, or use the HDR function to shoot when there are very bright areas and very dark areas in the same frame.

Changing (Auto) Mode Settings (Shooting Menu)

The following options can be set when shooting in  (auto) mode ( 22).

Image mode  44

Choose the image mode (combination of image size and compression rate) at which images are saved. This setting can be changed when using any shooting mode.

White balance  46

In order to make the colors in images appear as they do to the eye, set white balance to suit the light source.

Metering  48

Choose how the camera meters exposure.

ISO sensitivity  49

Set the ISO sensitivity to suit the brightness of the subject.

AF area mode  50

Choose how the camera selects the focus area for autofocus.

Autofocus mode  54

Choose how the camera focuses.

Displaying the Shooting Menu

Rotate the mode dial to  (auto) mode ( 42).

Press the **MENU** button to display the shooting menu.

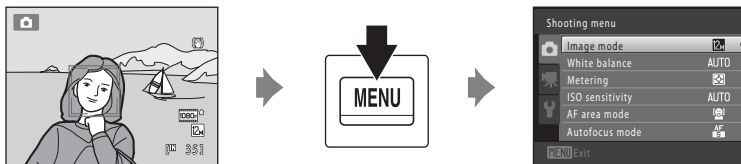

- Use the rotary multi selector to choose and apply settings ( 9).
- To exit the shooting menu, press the **MENU** button.













Camera Settings that Cannot Be Applied Simultaneously

Some functions cannot be enabled in conjunction with others ( 78).

Image Mode (Image Quality/Image Size)

 (auto) → MENU (Shooting menu) → Image mode

Image mode refers to the combination of image size and image quality (compression) at which images are saved. Choose the image mode best suited to the manner in which images will be used and the capacity of the internal memory or memory card. The higher the image mode setting, the larger the size at which it can be printed or displayed without appearing noticeably “grainy,” but limiting the number of images that can be saved.

Image mode	Size (pixels)	Description
 4000 × 3000★	4000 × 3000	Images will be higher quality than  . The compression ratio is approximately 1:4.
 4000 × 3000 (default setting)	4000 × 3000	Best choice in most situations. The compression ratio is approximately 1:8.
 3264 × 2448	3264 × 2448	
 2592 × 1944	2592 × 1944	
 2048 × 1536	2048 × 1536	Smaller size than  ,  , or  allows more images to be saved. The compression ratio is approximately 1:8.
 1024 × 768	1024 × 768	Suited to display on a computer monitor. The compression ratio is approximately 1:8.
 640 × 480	640 × 480	Suited to full-screen display on a television with an aspect ratio of 4:3, or distribution by e-mail. The compression ratio is approximately 1:8.
 3968 × 2232	3968 × 2232	Images with an aspect ratio of 16:9 are saved. The compression ratio is approximately 1:8.











The icon for the current setting is displayed in the monitor in shooting and playback modes ( 6, 7).

Image Mode

- When using shooting modes other than  (auto) mode, this setting can be changed by pressing the MENU button.
- The setting is also applied to other shooting modes.
- This function cannot be used simultaneously with certain functions. See “Camera Settings that Cannot Be Applied Simultaneously” ( 78) for more information.

 **Number of Exposures Remaining**

The following table lists the approximate number of images that can be saved in the internal memory and on a 4 GB memory card. Note that due to JPEG compression, the number of images that can be saved differs depending on the composition of the image. In addition, this number may vary depending on the make of memory card, even when the memory cards have the same specified capacity.

Image mode	Internal memory (approx. 102 MB)	Memory card ¹ (4 GB)	Print size ² (cm/in.)
 4000 × 3000★	17	650	34 × 25/13 × 10
 4000 × 3000	35	1280	34 × 25/13 × 10
 3264 × 2448	52	1910	28 × 21/11 × 8
 2592 × 1944	81	2940	22 × 16/8.5 × 6.5
 2048 × 1536	126	4640	17 × 13/7 × 5
 1024 × 768	411	15000	9 × 7/3.5 × 2.5
 640 × 480	731	24100	5 × 4/2 × 1.5
 3968 × 2232	47	1720	34 × 19/13 × 7.5

¹ If the number of exposures remaining is 10,000 or more, the number of exposures remaining display shows “9999.”

² Print size at an output resolution of 300 dpi. Print sizes are calculated by dividing the number of pixels by printer resolution (dpi) and multiplying by 2.54 cm (1 in.). However, at the same image size, images printed at higher resolutions will print smaller than the size indicated, and those printed at lower resolutions will print larger than the size indicated.

White Balance (Adjusting Hue)

 (auto) → MENU (Shooting menu) → White balance

The color of light reflected from an object varies with the color of the light source. The human brain is able to adapt to changes in the color of the light source, with the result that white objects appear white whether seen in the shade, direct sunlight, or under incandescent lighting. Digital cameras can mimic this adjustment by processing images according to the color of the light source. This is known as “white balance.” For natural colors, choose a white balance setting that matches the light source before shooting. Although the default setting, **Auto**, can be used under most types of lighting, the white balance setting suited to a particular light source can be specified manually to achieve more accurate results.

AUTO Auto (default setting)

White balance is automatically adjusted to suit lighting conditions. Best choice in most situations.

PRE Preset manual

Useful when shooting under unusual lighting. See “Preset Manual” for more information ( 47).

Daylight

White balance adjusted for direct sunlight.

Incandescent

Use under incandescent lighting.

Fluorescent

Use under fluorescent lighting.

Cloudy





Use when taking pictures under overcast skies.

Flash



Use with the flash.

The icon for the current setting is displayed in the monitor ( 6). However, when **Auto** is selected, no icon is displayed.

Notes on White Balance

- When hue is adjusted using the creative slider ( 38), this feature cannot be set.
- This function cannot be used simultaneously with certain functions. See “Camera Settings that Cannot Be Applied Simultaneously” ( 78) for more information.
- At white-balance settings other than **Auto** or **Flash**, turn the flash off (  30).



White Balance Settings

This setting can be set by pressing the **MENU** button even when using continuous shooting mode ( 73).  (auto) mode and continuous shooting mode share the same **White balance** setting.

Preset Manual

Preset manual is used with mixed lighting or to compensate for light sources with a strong color cast when the desired effect has not been achieved with white balance settings like **Auto** and **Incandescent** (for example, to make images shot under a lamp with a red shade look as though they had been shot under white light).

Use the procedure below to measure the white balance value under the lighting used during shooting.

- 1 Place a white or gray reference object under the lighting that will be used during shooting.
- 2 Display the shooting menu ( 43), use the rotary multi selector to choose **PRE Preset manual** in the **White balance** menu, and press the  button.

The camera zooms in to the position for measuring white balance.

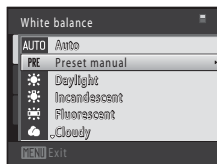

- 3 Choose **Measure**.

To apply the most recently measured white balance value, choose **Cancel** and press the  button. The white balance setting will not be measured again and the most recently measured value will be set.

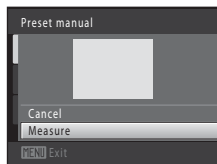

- 4 Frame the reference object in the measuring window.

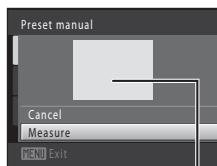

Measuring window

- 5 Press the  button to measure a value for preset manual.

The shutter is released and the new white-balance value is set. No image is saved.

Note on Preset Manual

A value for flash lighting cannot be measured with **Preset manual**. When shooting using the flash, set **White balance** to **Auto** or **Flash**.

Metering

 (auto) → MENU (Shooting menu) → Metering

The process of measuring the brightness of the subject to determine exposure is known as metering.

Choose how the camera meters exposure.

Matrix (default setting)

Uses a wide area of the screen for metering. This metering mode provides the appropriate exposure for a variety of shooting conditions. Recommended for typical shooting.

Center-weighted



The camera meters the entire frame but assigns greatest weight to the subject in the center of the frame. Classic meter for portraits; preserves background details while letting lighting conditions at the center of the frame determine exposure. Can be used with focus lock ( 51) to meter off-center subjects.

More on Shooting

Note on Metering

While digital zoom is in effect, metering is set to center-weighted or spot metering. However, the active metering area is not displayed.

Metering Settings

This setting can be set by pressing the **MENU** button even when using continuous shooting mode ( 73).  (auto) mode and continuous shooting mode share the same **Metering** setting.

Metering Area

The active metering area is displayed in the monitor when **Center-weighted** is selected for **Metering**.

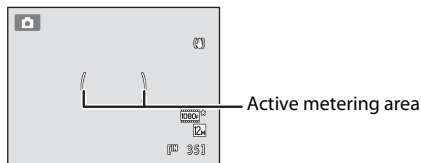

ISO Sensitivity

 (auto) → MENU (Shooting menu) → ISO sensitivity

When ISO sensitivity is increased, less light is needed when taking pictures. Higher ISO sensitivity allows darker subjects to be captured. Additionally, even with subjects of similar brightness, pictures can be taken at faster shutter speeds, and blurring caused by camera shake and subject movement can be reduced.

- Although higher ISO sensitivity is effective when shooting darker subjects, shooting without the flash, shooting with the camera zoomed in, etc., images may contain noise.

Auto (default setting)

Sensitivity is ISO 160 when there is sufficient lighting; the camera compensates by raising sensitivity to a maximum of ISO 800 when lighting is dim.



Fixed range auto

Limits the ISO sensitivity to ISO 160-400 when the camera automatically adjusts ISO sensitivity. Set the maximum value for ISO sensitivity to 400 for effective control over the amount of “grain” that appears in images.



160, 200, 400, 800, 1600, 3200

Sensitivity is locked at the specified value.



The icon for the ISO sensitivity setting is displayed in the monitor ( 6).

- When **Auto** is selected, the  icon is not displayed at ISO 160, but is displayed if the ISO sensitivity automatically increases to more than 160 ( 31).
- When **Fixed range auto** is selected,  400 is displayed.

Notes on ISO Sensitivity

- This function cannot be used simultaneously with certain functions. See “Camera Settings that Cannot Be Applied Simultaneously” ( 78) for more information.
- **Motion detection** ( 168) does not function when the ISO sensitivity is set to any setting other than **Auto**.

ISO Sensitivity Settings

This setting can be set by pressing the **MENU** button even when using continuous shooting mode ( 73).  (auto) mode and continuous shooting mode share the same **ISO sensitivity** setting.

AF Area Mode

 (auto) → MENU (Shooting menu) → AF area mode

Use this option to determine how the camera selects the focus area for autofocus.

Face priority (default setting)

When the camera detects a human face, it focuses on that face. See “Face Detection” ( 52) for more information. If more than one face is detected, the camera focuses on the face closest to the camera. When taking pictures of subjects other than people, or framing a subject with which no face is detected, the **AF area mode** setting switches to **Auto**, and the camera will automatically select the focus area (up to nine areas) containing the subject closest to the camera.

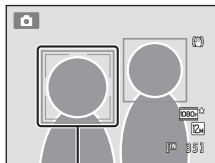

Focus area

Auto



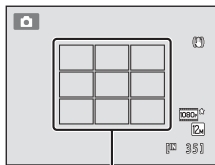

The camera has nine focus areas, and automatically selects the focus areas containing the subject closest to the camera. Press the shutter-release button halfway to activate the focus area. When the shutter-release button is pressed halfway, the focus areas that are in focus (up to nine areas) selected by the camera will be displayed in the monitor.





Focus areas

Manual

Select one of 99 focus areas in the monitor. This option is suited to situations in which the intended subject is relatively still and not positioned in the center of the frame.

Rotate the rotary multi selector or press , , , or  to move the focus area to where the subject is, and take a picture.

To cancel focus area selection and change flash, macro mode, or self-timer settings, or adjust brightness, vividness, or hue, first press the  button. To return to the focus area selection screen, press the  button again.

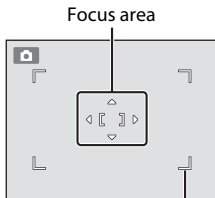

Selectable focus area

Center

The camera focuses on the subject at the center of the frame.

The focus area is always displayed at the center of the screen.

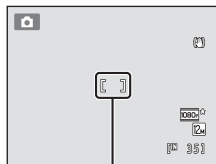

Focus area

Notes on AF Area Mode

- When digital zoom is in effect, focus will be on the center of the screen regardless of the **AF area mode** setting.
- This function cannot be used simultaneously with certain functions. See “Camera Settings that Cannot Be Applied Simultaneously” (📖 78) for more information.
- Autofocus may not perform as expected (📖 27).

AF Area Mode Settings

This setting can be set by pressing the **MENU** button even when using continuous shooting mode (📖 73).  (auto) mode and continuous shooting mode share the same **AF area mode** setting.

Focus Lock

Use focus lock to focus on off-center subjects when center is selected for AF area mode.







The following steps explain the usage of focus lock when **Center** is selected for **AF area mode**.

- 1 Position the subject in the center of the frame.
- 2 Press the shutter-release button halfway.
 - Confirm that the focus area glows green.
 - Focus and exposure are locked.
- 3 Continue holding down the shutter-release button halfway and recompose the picture.
 - Be sure to maintain the same distance between the camera and the subject while the shutter-release button is pressed halfway.
- 4 Press the shutter-release button the rest of the way down to take the picture.



Face Detection

When the camera is pointed at a human face, face detection, which the camera automatically detects that face and focus on it, starts. The face detection function is activated in the following situations.



- When AF area mode is set to **Face priority** in  (auto) mode or continuous shooting mode ( 50)
- When the following scene modes are selected:
 - Scene auto selector ( 56)
 -  (night portrait) ( 59)
 - **Portrait** ( 61)
- When smile timer is selected ( 34)

1 Frame a picture.

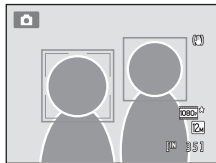
When the camera detects a face, that face is framed by a yellow double border.



When the camera detects more than one face, operation varies as follows depending upon the shooting mode.

Shooting mode	Face framed by double border	Number of faces that can be detected
 (auto) mode or continuous shooting mode (Face priority)	The face closest to the camera <ul style="list-style-type: none"> • Other faces framed by single border. 	Up to 12
Scene auto selector,  (night portrait), and Portrait scene modes		
Smile timer	The face closest to the center of the frame <ul style="list-style-type: none"> • Other faces framed by single border. 	Up to 3

2 Press the shutter-release button halfway.

The camera focuses on the face framed by the double border. The double border turns green and focus is locked.



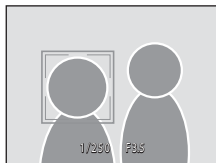

When the camera is unable to focus, the double border will blink. Press the shutter-release button halfway again to focus.

Press the shutter-release button the rest of the way down to take a picture.

When the shutter-release button is pressed all the way when using smile timer, smile detection begins, and the camera releases the shutter automatically when it detects a smiling face ( 34).



Notes on Face Detection

- If the camera is unable to detect any faces when the shutter-release button is pressed halfway with AF area mode set to **Face priority**, the AF area mode setting automatically switches to **Auto**.
- If no faces are detected when the shutter-release button is pressed halfway in the **Portrait** and  (night portrait) scene modes, the camera will focus on the subject at the center of the frame.
- The camera's ability to detect faces depends on a variety of factors, including whether or not the subject is facing the camera. The camera may be unable to detect faces in the following situations:
 - When faces are partially hidden by sunglasses or otherwise obstructed
 - When faces take up too much or too little of the frame
- When the frame includes more than one face, the faces detected by the camera and the face on which the camera focuses depend upon a variety of factors, including the direction in which the faces are looking.
- When using autofocus and shooting subjects that are difficult to focus on ( 27), the subject may not be in focus even though the double border is green. If the subject is not in focus, change AF area mode to **Manual** or **Center** in  (auto) mode, and try focus lock shooting ( 51) by focusing on another subject that is the same distance from the camera.
- Images captured using face detection will be rotated and displayed automatically according to the orientation of the faces detected, in full-frame and thumbnail playback modes (excluding images captured using continuous shooting mode ( 73)).

Autofocus Mode

 (auto) → MENU (Shooting menu) → Autofocus mode

Choose how the camera focuses.

 **Single AF (default setting)**

The camera focuses when the shutter-release button is pressed halfway.



 **Full-time AF**

The camera focuses continuously until the shutter-release button is pressed down halfway. Use with moving subjects. The sound of lens drive movement will be heard while the camera focuses.



Note on Autofocus Mode

There may be functions with which this setting cannot be enabled. See “Camera Settings that Cannot Be Applied Simultaneously” ( 78) for more information.

The Autofocus Mode Setting for Subject Tracking Mode and Continuous Shooting Mode

This setting can be set by pressing the **MENU** button even when using subject tracking mode ( 70) or continuous shooting mode ( 73).  (auto) mode and continuous shooting mode share the same setting, and the default setting is **Single AF**. The default setting for subject tracking mode is **Full-time AF**.

Autofocus Mode for Movie Recording

Autofocus mode for movie recording can be set with **Autofocus mode** ( 135) in the movie menu ( 132).

Shooting Suited to Scenes (Scene Mode)



When one of the following scenes is selected using the mode dial or the scene menu, images are captured using settings that are optimized for the selected scene.

 (Scene auto selector)
(📖 56)

By simply framing a picture, the camera automatically selects the optimum scene mode for simpler shooting.















 Night Landscape
(📖 58)
 Night Portrait (📖 59)
 Backlighting (📖 60)

Rotate the mode dial to , , or  and take pictures.

SCENE

Press the **MENU** button to display the scene menu and choose one of the following shooting scenes.

 Portrait (default setting) (📖 61)	 Landscape (📖 61)
 Party/indoor (📖 62)	 Beach (📖 62)
 Snow (📖 62)	 Sunset (📖 63)
 Dusk/dawn (📖 63)	 Close-up (📖 64)
 Food (📖 65)	 Museum (📖 66)
 Fireworks show (📖 66)	 Copy (📖 67)
 Panorama assist (📖 67)	

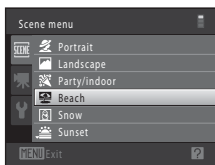
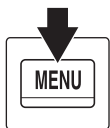
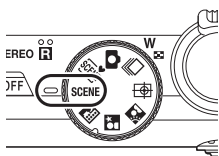







- Choose a scene type from the scene menu and rotate the zoom control (📖 4) to **T** (🔍) to view a description (help) of that scene. To return to the original screen, rotate the zoom control to **T** (🔍) again.

Image Mode

The **Image mode** setting (📖 44) can be changed by pressing the **MENU** button in scene mode. Changes made to the image mode setting apply to all shooting modes.

Shooting in the Scene Mode Selected by the Camera (Scene Auto Selector)

By simply framing a picture, the camera automatically selects the optimum scene mode for simpler shooting.

- : Auto (general shooting)
- : Landscape
- : Night landscape
- : Backlighting
- : Portrait
- : Night portrait
- : Close-up

1 Rotate the mode dial to



The camera enters scene auto selector.

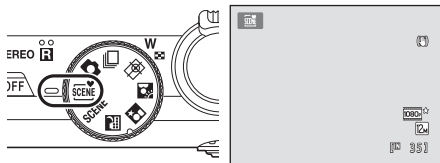

2 Frame the subject and take a picture.

The shooting mode icon changes.

Press the shutter-release button halfway to set focus and exposure. When the subject is in focus, the active focus area glows green.

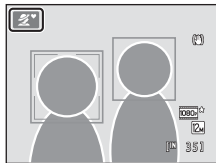

Press the shutter-release button the rest of the way down to take the picture.





✓ Notes on Scene Auto Selector

- Digital zoom is not available.
- Depending upon shooting conditions, the camera may not select the desired scene mode. Should this occur, switch to  (auto) mode (📖 22) or select the desired scene manually (📖 58).





✎ Focusing Using Scene Auto Selector

- When the camera detects a human face in scene auto selector, it focuses on that face. See “Face Detection” (📖 52) for more information.
- When the shooting mode indicator  or  (close-up) is displayed, the camera automatically selects the focus area (up to nine areas) containing the subject closest to the camera as same as when **Auto** is selected for **AF area mode** (📖 50).

✎ Shooting with Night Landscape and Night Portrait When Using Scene Auto Selector

- If the camera switches to  (night landscape) when using scene auto selector, slow shutter speeds are used to capture the ambience of night landscapes (the camera does not shoot continuously).
- If the camera switches to  (night portrait) when using scene auto selector, flash mode is fixed at slow sync with red-eye reduction for shooting human subjects (the camera does not shoot continuously).
- In dark surroundings, the use of a tripod is recommended. Set **Vibration reduction** (📖 166) to **Off** when using a tripod to stabilize the camera.

✎ Functions Available in Scene Auto Selector

-  **AUTO** (auto; default setting) and  (off) flash mode settings can be applied (📖 30). When  **AUTO** (auto) is applied, the camera automatically selects the optimum flash mode setting for the scene mode it has selected. When  (off) is applied, the flash does not fire, regardless of shooting conditions.
- The self-timer (📖 33) and exposure compensation (📖 37) settings can be adjusted.
- Smile timer (📖 34) cannot be used.
- The macro mode button on the rotary multi selector (📖 9, 36) is disabled.

Choosing a Scene and Shooting (Scene Mode Types and Characteristics)

The mode dial can be used to select scenes when shooting (📖 55).

See “Shooting in the Scene Mode Selected by the Camera (Scene Auto Selector)” (📖 56) for more information on scene auto selector.

The following icons are used for descriptions in this section: ⚡, flash mode (📖 30); ⌚, self-timer (📖 33); 🌸, macro mode (📖 36); 📷, exposure compensation (📖 37).

🌃 Night landscape

Produces night landscape shots with reduced blurring and noise. When the 🌃 icon at the top left of the monitor lights in green, press the shutter-release button all the way to capture a series of images at high speed which will be combined into a single image and saved.

- Camera focuses at infinity. When the shutter-release button is pressed halfway, the focus area or focus indicator (📖 6) always lights green. However, because the camera focuses at infinity, it may not be able to focus on nearby objects.
- Once the shutter-release button is pressed all the way, hold the camera steady without moving it until a still image is displayed. After taking a picture, do not turn the camera off before the monitor switches to the shooting screen.
- The angle of view (i.e., the area visible in the frame) seen in the saved image will be narrower than that seen in the monitor at the time of shooting.
- Digital zoom is not available.
- AF-assist illuminator (📖 169) does not light.



* Default setting can be modified.

Night portrait

Use this mode for portraits of a human subject shot in front of background lighting at night. Flash is used to illuminate the subject while maintaining the mood of the background.

When the  icon at the top left of the monitor lights in green, press the shutter-release button all the way to capture a series of images at high speed which will be combined into a single image and saved.



- When the camera detects a human face, it focuses on that face (see “Face Detection” (📖 52) for more information).
- If the camera detects multiple faces, the camera focuses on the face closest to the camera.
- The camera softens skin tones (in up to three faces) by applying the skin softening function before saving images (📖 35).
- If no face is detected, the camera will focus on the subject in the center of the frame.
- Once the shutter-release button is pressed all the way, hold the camera steady without moving it until a still image is displayed. After taking a picture, do not turn the camera off before the monitor switches to the shooting screen.
- The angle of view (i.e., the area visible in the frame) seen in the saved image will be narrower than that seen in the monitor at the time of shooting.
- If the subject moves while the camera is shooting continuously, the image may be distorted, overlapped, or blurred.
- Digital zoom is not available.
- Set **Vibration reduction** (📖 166) to **Off** when using a tripod to stabilize the camera.

			Off*		Off		0.0*
---	---	---	------	---	-----	---	------

* Default setting can be modified.



Shooting Suited to Scenes (Scene Mode)

Backlighting

Use when light is coming from behind the subject, throwing features or details into shadow.

Set **HDR** to **On** or **Off** in the  (backlighting) menu according to the shooting conditions and subject.

Press the **MENU** button to display the  (backlighting) menu.



- **Off** (default setting): The flash fires to prevent the subject from being hidden in shadow. The  icon is displayed at the top left of the monitor.
- **On**: Use when taking pictures with very bright and dark areas in the same frame. The  icon and the **HDR** icon are displayed at the top left of the monitor.

When **HDR** is set to **Off**:

- The camera focuses on the subject at the center of the frame.
- The flash fires regardless of the brightness of the subject when the shutter-release button is pressed all the way.



When **HDR** is set to **On**:

- The camera focuses on the subject at the center of the frame.
- When the shutter-release button is pressed all the way, the camera shoots images continuously at high speed, and saves the following two images.
 - An image processed by D-Lighting ( 125) at the time of shooting
 - HDR (high dynamic range) composite image (the effects of over-exposure and under-exposure are reduced)
- The second image saved is an HDR composite image. If only one image can be saved, an image processed by D-Lighting is the only image saved.
- If there are very bright areas and very dark areas in the frame, the  icon lights in green.
- Once the shutter-release button is pressed all the way, hold the camera steady without moving it until a still image is displayed.
- After taking a picture, it takes some time to save the image. Do not turn the camera off before the monitor switches to the shooting screen.
- The angle of view (i.e., the area visible in the frame) seen in the saved image will be narrower than that seen in the monitor at the time of shooting.
- Digital zoom is not available.



¹ When **HDR** is set to **On**, the flash mode is fixed at  (off).

² Default setting can be modified.

SCENE →  Portrait

Use this mode for portraits.

- The camera detects and focuses on a human face. See “Face Detection” (📖 52) for more information.
- If more than one face is detected, focus will be on the face closest to the camera.
- The camera softens skin tones (in up to three faces) by applying the skin softening function before saving images (📖 35).
- If no faces are detected, the camera focuses on the subject at the center of the frame.
- Digital zoom is not available.



* Default setting can be modified.

SCENE →  Landscape

Use this mode for vivid landscapes and cityscapes.

- Camera focuses at infinity. The focus area or focus indicator (📖 6) always glows green when the shutter-release button is pressed halfway. Note, however, that objects in the foreground may not always be in focus.
- AF-assist illuminator (📖 169) does not light.



* Default setting can be modified.

Shooting Suited to Scenes (Scene Mode)

SCENE → Party/indoor

Suitable for taking pictures in parties. Captures the effects of candlelight and other indoor background lighting.

- The camera focuses on the subject at the center of the frame.
- As images are easily affected by camera shake, hold the camera steadily. In dark surroundings, the use of a tripod is recommended. Set **Vibration reduction** (📖 166) to **Off** when using a tripod to stabilize the camera.



¹ Slow sync with red-eye reduction flash mode may be used. The default setting can be modified.

² Default setting can be modified.

SCENE → Beach

Captures the brightness of such subjects as beaches or sunlit expanses of water.

- The camera focuses on the subject at the center of the frame.



* Default setting can be modified.

SCENE → Snow

Captures the brightness of sunlit snow.

- The camera focuses on the subject at the center of the frame.



* Default setting can be modified.

SCENE →  Sunset

Preserves the deep hues seen in sunsets and sunrises.



- The camera focuses on the subject at the center of the frame.



* Default setting can be modified.



SCENE →  Dusk/dawn

Preserves the colors seen in the weak natural light before sunrise or after sunset.

- Camera focuses at infinity. The focus area or focus indicator ( 6) always glows green when the shutter-release button is pressed halfway. Note, however, that objects in the foreground may not always be in focus.
- AF-assist illuminator ( 169) does not light.



* Default setting can be modified.

: Use of a tripod is recommended in scenes with which  is indicated. Set **Vibration reduction** ( 166) to **Off** when using a tripod to stabilize the camera.

SCENE → 🌸 Close-up

Photograph flowers, insects, and other small objects at close range.

- Macro mode (📖 36) is enabled and the camera automatically zooms to the closest position at which it can focus.
- The closest distance at which the camera can focus varies depending on the zoom position. When the zoom is at a position where 🌸 and the zoom indicator glow green (to the left of 📏), the camera can focus on subjects as close as 2 cm (0.8 in.) from the lens.

At the maximum wide-angle position, the camera can focus on subjects as close as 1 cm (0.4 in.) from the lens.













- **AF area mode** is set to **Manual** and the focus area in which the camera focuses can be selected (📖 50). Press the **OK** button and then move the focus area by rotating the rotary multi selector or by pressing ▲, ▼, ◀, or ▶. Press the **OK** button again to lock the selected focus area. Flash mode and exposure compensation settings can be adjusted and the self-timer can be enabled while the focus area is locked.
- The camera focuses continuously until the shutter-release button is pressed halfway to lock the focus.
- As images are easily affected by camera shake, be sure that **Vibration reduction** (📖 166) is enabled and hold the camera steadily.



* Default setting can be modified. Note that the flash may be unable to light entire subject at distances of less than 50 cm (1 ft. 8 in.).

SCENE →  Food

Use this mode when taking pictures of food.

- Macro mode ( 36) is enabled and the camera automatically zooms to the closest position at which it can focus.
- The closest distance at which the camera can focus varies depending on the zoom position. When the zoom is at a position where  and the zoom indicator glow green (to the left of ) , the camera can focus on subjects as close as 2 cm (0.8 in.) from the lens. At the maximum wide-angle position, the camera can focus on subjects as close as 1 cm (0.4 in.) from the lens.
- Hue can be adjusted in the range of the slider displayed on the left in the monitor. Press the rotary multi selector  to make the image more reddish, or  to make it more bluish. The hue setting is saved in the camera's memory even after the camera is turned off.
- **AF area mode** is set to **Manual** and the focus area in which the camera focuses can be selected ( 50). Press the  button and then move the focus area by rotating the rotary multi selector or by pressing , , , or . Press the  button again to lock the selected focus area. Hue and exposure compensation settings can be adjusted and the self-timer can be enabled while the focus area is locked.
- The camera focuses continuously until the shutter-release button is pressed halfway to lock the focus.
- As images are easily affected by camera shake, be sure that **Vibration reduction** ( 166) is enabled and hold the camera steadily.

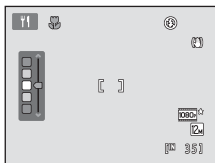



			Off*		On		0.0*
---	---	---	------	---	----	---	------

* Default setting can be modified.

Shooting Suited to Scenes (Scene Mode)

SCENE → Museum

Use indoors where flash photography is prohibited (for example, in museums and art galleries) or in other settings in which you do not want to use the flash.



- Camera focuses on the subject at the center of the frame.
- BSS (best shot selector) can be enabled ( 75).
- As images are easily affected by camera shake, be sure that **Vibration reduction** ( 166) is enabled and hold the camera steadily.
- AF-assist illuminator ( 169) does not light.







* Default setting can be modified.

SCENE → Fireworks show

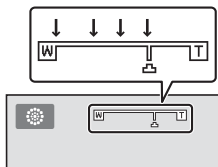
Slow shutter speeds are used to capture the expanding burst of light from a firework.

- Camera focuses at infinity. The focus indicator ( 6) always glows green when the shutter-release button is pressed halfway. Note, however, that objects in the foreground may not always be in focus.
- AF-assist illuminator ( 169) does not light.
- Only the four optical zoom positions shown on the right can be applied. When the zoom control is rotated, zoom will not stop at any position other than the four indicated (digital zoom is available).



: Use of a tripod is recommended in scenes with which  is indicated. Set **Vibration reduction** ( 166) to **Off** when using a tripod to stabilize the camera.

SCENE →  Copy

Provides clear images of text or drawings on a white board or in print.

- Camera focuses on the subject at the center of the frame.
- Use macro mode ( 36) to focus at short ranges.
- Colored text and drawings may not show up well.

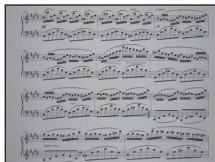

* Default setting can be modified.

SCENE →  Panorama assist

Use when taking a series of pictures that will later be joined to form a single panorama using the supplied Panorama Maker 5 software. See "Shooting for a Panorama" ( 68) for more information.



* Default setting can be modified.

Shooting for a Panorama

The camera focuses on the subject at the center of the frame. Use a tripod for the best results. Set **Vibration reduction** (📖 166) to **Off** in setup menu (📖 157) when using a tripod to stabilize the camera.

- 1 Rotate the mode dial to **SCENE**, press the **MENU** button and choose **Panorama assist** (📖 55).

Panorama direction icons are displayed to show the direction in which images will be joined.

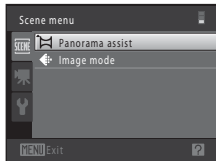
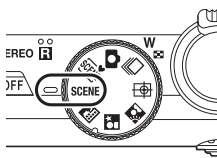

- 2 Use the rotary multi selector to choose the direction and press the **OK** button.

Select the direction in which images will be joined in the completed panorama; right (▶), left (◀), up (▲), or down (▼).

The yellow panorama direction icon (▶▶) is displayed for the current direction and the direction is fixed when the **OK** button is pressed. The icon changes to the white fixed direction ▶ icon.

If necessary, apply flash mode (📖 30), self-timer (📖 33), macro mode (📖 36), and exposure compensation (📖 37) settings with this step.

Press the **OK** button again to choose a different direction.



- 3 Frame the first portion of the panorama scene and take the first picture.

One third of the image will be displayed as translucent.



- 4 Take the next picture.

Frame the next image so that one third of the frame overlaps the first image, and press the shutter-release button.

Repeat this process until the necessary number of images has been taken to complete the scene.



5 Press the **OK** button when shooting is complete.

The camera returns to step 2.



✓ Notes on Panorama Assist

- Set flash mode, self-timer, macro mode and exposure compensation before taking the first picture. They cannot be changed after the first picture is taken. Images cannot be deleted, nor can zoom or **Image mode** setting (📖 44) be adjusted after the first picture is taken.
- Shooting for the panorama series is terminated if the auto off function (📖 171) initiates standby mode during shooting. Setting the time allowed to elapse before the auto off function is enabled to a longer setting is recommended.

🔦 AE/AF-L Indicator

In panorama assist mode, exposure, white balance, and focus for all images in a panorama are fixed at the values for the first image in each series.

When the first picture is taken, **AE/AF-L** is displayed to indicate that exposure, white balance, and focus are locked.

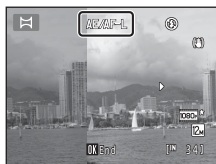

🔦 Panorama Maker 5

Install Panorama Maker 5 from the supplied ViewNX 2 CD.

Transfer images to a computer (📖 145) and use Panorama Maker 5 (📖 149) to join them in a single panorama.

🔦 More Information

See "Image/Sound File and Folder Names" (📖 185) for more information.

Focusing on a Moving Subject (Subject Tracking Mode)

Use this mode to take pictures of moving subjects. By registering a subject, the camera can move the focus area automatically to track the subject.

1 Rotate the mode dial to (subject tracking).

The camera enters subject tracking mode and a white border is displayed at the center of the frame.

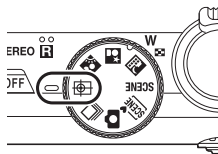

2 Register a subject.

Align the subject with the border at the center of the frame and press the  button.

- The subject is registered.
- When the camera is unable to focus on the subject, the border will glow red. Change the composition and try registering the subject again.

When the subject is registered, a yellow double border (focus area) is displayed around that subject.

To change the subject, press the  button to deregister the current subject.

If the camera cannot track the registered subject anymore, the focus area will disappear and the registration will be canceled. Register the subject again.



3 Press the shutter-release button to take a picture.

The camera focuses on the focus area when the shutter-release button is pressed halfway. The focus area will glow green and focus will be locked.

When the camera is unable to focus, the focus area will blink. Press the shutter-release button halfway again to focus.

If the shutter-release button is pressed halfway while the focus area is not displayed, the camera focuses on the subject at the center of the frame.

Press the shutter-release button all the way down to release the shutter.

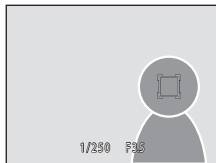

✓ Notes on Subject Tracking Mode

- Digital zoom is not available.
- Adjust zoom position, flash mode, exposure compensation, and menu settings prior to registering the subject. If any camera setting is changed after the subject has been registered, subject registration will be canceled.
- It may be impossible to register the desired subject, or the camera may be unable to track the registered subject or may begin tracking a different subject, if the subject is moving rapidly, if there is a significant amount of camera shake, or if the camera detects a similar subject. The camera's ability to accurately track the registered subject is also dependent upon the size and brightness of the subject.
- When using autofocus and shooting subjects that are difficult to focus on (📖 27), the subject may not be in focus even though the focus area glows green. If the subject is not in focus, change **AF area mode** (📖 50) to **Manual** or **Center** in  (auto) mode, and try focus lock shooting (📖 51) by focusing on another subject that is the same distance from the camera.

✍ Functions Available in Subject Tracking Mode

- Flash mode (📖 30) and exposure compensation (📖 37) settings can be adjusted.
- Self-timer (📖 33) and macro mode (📖 36) cannot be used.
- Press the **MENU** button to display the  (subject tracking) menu and adjust **Image mode** or **Autofocus mode** (📖 72).

Changing Subject Tracking Mode Settings

While using  (subject tracking) mode (📖 70), press the **MENU** button (📖 8) and then set the following options in the subject tracking menu.

- Use the rotary multi selector to choose and apply settings (📖 9, 10).
- Press the **MENU** button to exit the menu.

Image mode

Choose the image mode (combination of image size and compression rate) at which images are saved (📖 44).

Changes made to the image mode setting apply to all shooting modes.

Autofocus mode

Set **Autofocus mode** (📖 54) used for subject tracking mode (the default setting is **Full-time AF**).

When using subject tracking mode while set to **Full-time AF**, the camera continuously focuses once a subject is registered for subject tracking until the shutter-release button is pressed halfway to lock the focus. The sound of lens drive movement can be heard.

Changes made to the autofocus mode setting in this mode will not be applied to the autofocus mode setting in  (auto) mode and continuous shooting mode. The autofocus mode setting applied in subject tracking mode is saved in the camera's memory even after the camera is turned off.

Burst Shooting (Continuous Shooting Mode)

Use this mode to capture the details of a moving subject by shooting a continuous series of images.

- The focus, exposure, and white balance settings are fixed at the values for the first picture in each series.

1 Rotate the mode dial to (continuous).

The camera enters continuous shooting mode.

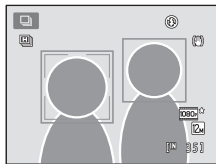
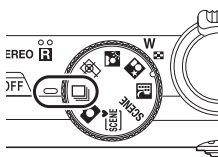

2 Press the **MENU** button and confirm or change the settings in the continuous menu.

See "Continuous Menu" (📖 75) for more information.
Press the **MENU** button after changing the settings and return to the shooting screen.

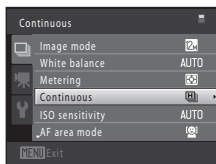

3 Frame the subject and shoot.

If the camera detects a human face, it focuses on that face.
See "Face Detection" (📖 52) for more information.

If the camera does not detect any faces, the camera selects the focus areas (up to nine areas) containing the subject closest to the camera.

Press the shutter-release button halfway to lock focus and exposure.

When **Continuous H**, **Continuous L**, **Pre-shooting cache**, or **BSS** is selected in the continuous menu, images are captured while the shutter-release button is held all the way down.

When **Sport continuous** or **Multi-shot 16** is selected in the continuous menu, the number of images determined by the setting are captured when the shutter-release button is pressed all the way. There is no need to hold the shutter-release button down.

After taking a picture, the camera returns to the shooting screen. If  is displayed, do not turn the camera off.

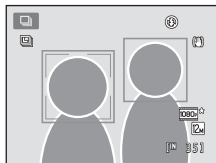

Burst Shooting (Continuous Shooting Mode)

Notes on Continuous Shooting Mode

- It may take some time to save the images after shooting. The amount of time it takes to finish saving the captured images depends on the number of images, image mode, the write speed of the memory card, etc.
- When ISO sensitivity increases, noise may appear in captured images.
- The speed of continuous shooting may decrease depending on the image mode, type of memory card used, and shooting conditions.
- When **Continuous** is set to **Pre-shooting cache**, **Sport continuous**, or **Multi-shot 16**, banding or variance in brightness or hue may occur in images that were captured under lighting that flickers at high speeds, such as fluorescent, mercury-vapor, or sodium-vapor lighting.
- When **Continuous** is set to **Pre-shooting cache** or **Sport continuous**, accurate exposure may not be achieved (images may be over-exposed) in images captured on bright sunny days.
- Note that shooting stops when the flash is lowered while shooting with the continuous shooting feature.

Functions Available in Continuous Shooting Mode

- Flash and self-timer cannot be used.
- Brightness (exposure compensation), vividness, and hue can be adjusted with the creative slider (📖 37).
- Press the **MENU** button to display the  (continuous) menu and change continuous shooting mode settings (📖 75).

Images Captured in Continuous Shooting Mode

Each time images are captured using **Continuous H**, **Continuous L**, **Sport continuous**, or **Pre-shooting cache**, the captured images are saved as a “sequence” (📖 83).

More Information

- See “Autofocus” (📖 27) for more information.
- See “Playing Images Captured Using Continuous Shooting Mode (Sequence)” (📖 83) for more information.

Changing Continuous Shooting Mode Settings

After displaying the  (continuous) mode shooting screen (📖 73), press the **MENU** button (📖 8) to set the following options in the continuous menu.

- Items other than **Continuous** share the same settings with  (auto) mode, and the settings are saved in the camera's memory even if the camera is turned off.
- Use the rotary multi selector to choose and apply settings (📖 9, 10).
- To exit the shooting menu, press the **MENU** button.
- Some functions cannot be enabled in conjunction with others (📖 78).

Image mode 44

Choose the image mode (combination of image size and compression rate) at which images are saved (except for **Sport continuous** and **Multi-shot 16**). Changes made to the image mode setting apply to all shooting modes.

White balance 46



In order to make the colors in images appear as they do to the eye, set white balance to suit the light source.

Metering 48



Choose how the camera meters exposure.

Continuous

Choose the desired continuous shooting option.
Continuous settings can be confirmed in the monitor when shooting (📖 6).

Option	Description
 Continuous H (default setting)	While the shutter-release button is held all the way down, images are captured continuously at a rate of about ten fps. Shooting ends when the shutter-release button is released, or five pictures have been taken.
 Continuous L	While the shutter-release button is held all the way down, up to 26 images are captured continuously at a rate of up to about 1.8 fps. Shooting ends when the shutter-release button is released.

Burst Shooting (Continuous Shooting Mode)

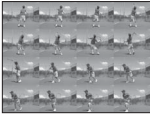
Option	Description
 Pre-shooting cache	<p>Pre-shooting cache makes it easy to capture perfect moments, by saving images from before the shutter-release button was pressed all the way. Pre-shooting cache shooting begins when the shutter-release button is pressed halfway, and continues when the shutter-release button is pressed all the way (📖 77).</p> <ul style="list-style-type: none"> • Frame rate: up to 5 fps • Number of frames: Up to five frames (including up to two frames captured in the pre-shooting cache) <p>Shooting ends when the shutter-release button is released or when the maximum number of frames has been shot.</p>
1/20 Sport continuous	<p>Each time the shutter-release button is pressed all the way, 54 frames are captured at a speed of about 1/120 s or faster.</p> <p>Image mode is fixed at LM (image size: 1280 × 960 pixels).</p>
BSS BSS (best shot selector)	<p>The “best shot selector” is recommended when shooting with the flash off or the camera zoomed in, or in other situations in which inadvertent motion can result in blurred images. The camera captures a series of up to five images while the shutter-release button is held all the way down, and the sharpest image in the series is automatically selected and saved.</p> <ul style="list-style-type: none"> • BSS is best suited to shooting subjects that are not moving. When shooting moving subjects or when the composition of the picture changes while shooting, the desired results may not be achieved.
 Multi-shot 16	<p>Each time the shutter-release button is pressed, camera takes 16 shots at a rate of about 30 fps and arranges them in a single image.</p> <ul style="list-style-type: none"> • Image mode is fixed at 5M (image size: 2560 × 1920 pixels). • Digital zoom is not available. 

ISO sensitivity

49

Set the ISO sensitivity to suit the brightness of the subject.

AF area mode

50

Use this option to determine how the camera selects the focus area for autofocus.

Autofocus mode

54

Choose how the camera focuses.

Pre-shooting Cache

When **Pre-shooting cache** is selected, shooting begins when the shutter-release button is pressed halfway for 0.5 seconds or longer, and images captured before the shutter-release button is pressed all the way are saved along with images captured after the shutter-release button is pressed all the way. Up to two images can be saved in the pre-shooting cache.

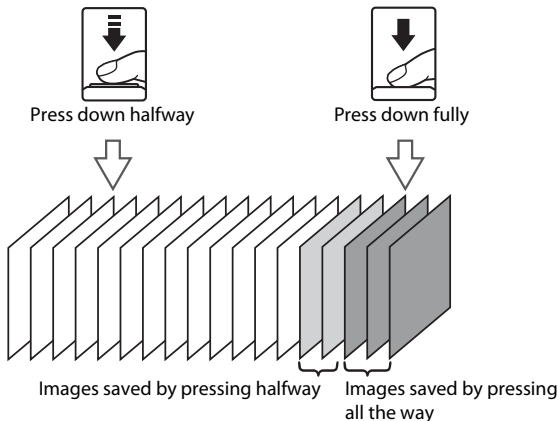

The pre-shooting cache setting can be confirmed in the monitor when shooting (6). When the pre-shooting cache is not set, no icon is displayed. The pre-shooting cache icon lights in green while the shutter-release button is pressed halfway.



- If the number of exposures remaining is less than five, shooting with the pre-shooting cache is not possible. Before shooting, check that there are five or more exposures remaining.

Camera Settings that Cannot Be Applied Simultaneously

Some settings in the  (auto) mode and continuous shooting mode menus cannot be used with other functions.

Restricted function	Setting	Descriptions
Image mode	Continuous (📖 73)	When using Sport continuous , image mode is fixed at  (image size: 1280 × 960 pixels). When using Multi-shot 16 , image mode is fixed at  (image size: 2560 × 1920 pixels).
White balance	Hue (using the creative slider) (📖 38)	When hue is adjusted using the creative slider, White balance in the shooting menu cannot be set.
	Continuous (📖 73)	When shooting with Pre-shooting cache or Sport continuous , White balance is fixed at Auto .
Metering	Continuous (📖 73)	When shooting with Pre-shooting cache or Sport continuous , Metering is fixed at Matrix .
ISO sensitivity	Continuous (📖 73)	When shooting with Continuous L , 3200 cannot be selected. If Continuous L is selected when ISO sensitivity is set to 3200 , sensitivity changes to 1600 .
		When shooting with Pre-shooting cache , Sport continuous , or Multi-shot 16 , the ISO sensitivity setting is automatically set according to the brightness.
AF area mode	Smile timer (📖 34)	Face detection is used regardless of the AF area mode setting.
	Continuous (📖 73)	When shooting with Pre-shooting cache or Sport continuous , AF area mode is fixed at Center .
Autofocus mode	Continuous (📖 73)	When shooting with Pre-shooting cache or Sport continuous , Autofocus mode is fixed at Single AF .
Date imprint	Continuous (📖 73)	When using any setting other than Multi-shot 16 , the date is not imprinted.
Motion detection	ISO sensitivity (📖 49)	Motion detection is disabled when the ISO sensitivity is set to any setting other than Auto .

Restricted function	Setting	Descriptions
AF assist	Continuous (📖 73)	When shooting with Pre-shooting cache or Sport continuous , the AF-assist illuminator does not light.
Digital zoom	Continuous (📖 73)	When using Multi-shot 16 , digital zoom is disabled.
Blink warning	Smile timer (📖 34)	Blink warning does not function.

✔ Features Not Available in Continuous Shooting Mode



When using continuous shooting mode, the following features cannot be used.

- Flash mode (📖 30)
- Self-timer (📖 33)/smile timer (📖 34)
- Motion detection (📖 168)
- Blink warning (📖 175)

💡 More Information







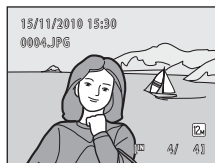















See "Notes on Digital Zoom" (📖 169) for more information.











Operations in Full-frame Playback Mode

Press the  (playback) button in shooting mode to enter playback mode and display images that have been captured ( 28).





The following operations are available in full-frame playback mode.

Function	Control	Description	
Select images		Press  ,  ,  , or  to display previous or next images. Press and hold  ,  ,  , or  to scroll quickly through images. Images can also be selected by rotating the rotary multi selector.	9
Switch to thumbnail display/calendar display mode (except for list by date mode)	W 	Rotate the zoom control to W  to display 4, 9, or 16 image thumbnails. Rotate the zoom control to W  with 16 thumbnails displayed to switch to calendar display.	85, 87
Select a different shooting date (list by date mode)	W 	Return to the list by date screen.	104
Playback zoom	T 	Rotate the zoom control to T  to enlarge the image up to 10x. Press the  button to return to full-frame playback mode.	88
Display shooting information		Display the histogram and the shooting information. Press the  button to return to full-frame playback.	82
Display individual images of a sequence		If pressed when displaying a sequence that is displayed by its key picture only, all images in the sequence are displayed as individual images. To return to key picture only display, press the rotary multi selector  .	83
Play back movies		Play back the movie currently displayed.	140

Function	Control	Description	
Delete images		Select a deletion method and delete images. When using favorite pictures mode ( 92), auto sort mode ( 100), or list by date mode ( 104), images in the same album, category, or shooting date can be deleted.	29, 84
Display menus	MENU	Display the menu for the selected mode.	107
Switch to another playback mode	MENU	Display the menu and select the MODE (playback mode) tab to switch to favorite pictures mode, auto sort mode, or list by date mode.	90
Switch to shooting mode		Press the  button or shutter-release button. The  (movie-record) button can also be used to switch to shooting mode.	28
			
			

Changing the Orientation (Vertical/Horizontal) of Images

Image orientation can be changed after taking a picture using **Rotate image** ( 116) in the playback menu ( 107).

Displaying the Histogram and Shooting Information

Press the **OK** button in full-frame playback mode to display the highlight, histogram, and the shooting information (not possible with movies). Press the **OK** button again to return to full-frame playback mode.

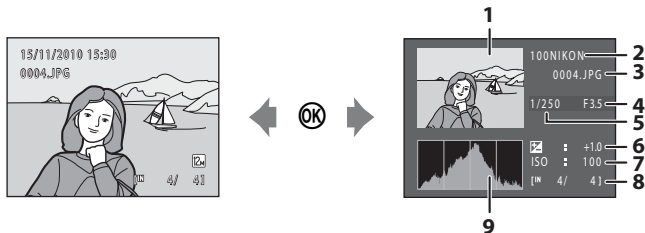

- 1** Highlight¹
- 2** Folder name
- 3** File name
- 4** Aperture
- 5** Shutter speed

- 6** Exposure compensation
- 7** ISO sensitivity
- 8** Current frame number/
total number of frames
- 9** Histogram²

¹ Areas of the image that are extremely bright (highlight areas) blink. Use as a guide when using exposure compensation to adjust image brightness.

² A histogram is a graph showing the distribution of tones in the image. The horizontal axis corresponds to brightness, with dark tones to the left and bright tones to the right. The vertical axis shows the number of pixels.

Playing Images Captured Using Continuous Shooting Mode (Sequence)

Each time the following continuous shooting mode (📖 73) settings are used to take pictures, the captured images are saved as a “sequence”.

- Continuous H
- Continuous L
- Sport continuous
- Pre-shooting cache

In full-frame playback mode or thumbnail playback mode (📖 85), the first image of a sequence is used as the “key picture”, i.e., it is displayed to represent the images in the sequence.

- 📄 is displayed in the playback screen for images captured in a sequence (📖 7).



While the key picture of a sequence is displayed in full-frame playback mode, press the **OK** button to display each image in the sequence individually. To return to key picture only display, press the rotary multi selector **▲**.

The following operations are available when each image in a sequence is displayed individually.

- Choose an image: Rotate the rotary multi selector or press **◀** or **▶**.
- Zoom in: Rotate the zoom control to **T** (📖 88).
- Display the histogram and shooting information: Press the **OK** button (📖 82).

Sequence Display Options



Select **Sequence display options** (📖 121) in the playback menu to set all sequences to be displayed using their key pictures or to display them as individual images.

Changing Key Picture in Sequence

A sequence's key picture can be changed using **Choose key picture** (📖 121) in the playback menu.

Deleting Images in a Sequence

If images in a sequence are selected and the  button is pressed when **Sequence display options** is set to **Key picture only**, the deletion method can be selected.

- **Erase current picture:** Delete only the image that is displayed ( 29).
- **Erase selected images:** Select images for deletion ( 29).
- **Erase entire sequence:** Delete all images in the sequence that is being played back.
- To exit without deleting, press the rotary multi selector ◀.

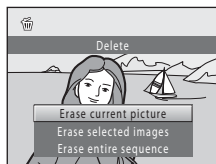

Note on Sequence

Images captured continuously with cameras other than the COOLPIX S8100 cannot be displayed as a sequence.

Playback Menu Options Available When Using Sequence

When the **MENU** button is pressed during key picture playback, the following menu operations are available for the images in that sequence.

- Quick retouch¹ ( 124)
- Skin softening¹ ( 126)
- Slide show ( 113)
- Rotate image¹ ( 116)
- Voice memo¹ ( 117)
- Sequence display options ( 121)
- Favorite pictures² ( 92)
- D-Lighting¹ ( 125)
- Print set² ( 109)
- Protect² ( 114)
- Small picture¹ ( 127)
- Copy² ( 119)
- Choose key picture ( 121)

¹ Press the **MENU** button after displaying individual images. Settings can be applied to individual images.

² When the **MENU** button is pressed during key picture playback, the same settings can be applied to all images in that sequence. Press the **MENU** button after displaying individual images to apply settings to individual images.

Viewing Multiple Images: Thumbnail Playback

Rotate the zoom control to **W** (📐) in full-frame playback mode (📖 80) to display images in “contact sheets” of thumbnail images (except in list by date mode).



The following operations are available while thumbnails are displayed.

Function	Control	Description	📖
Choose images		Rotate the rotary multi selector, or press ▲, ▼, ◀ or ▶.	9
Increase the number of images displayed/apply the calendar display	W (📐)	Rotate the zoom control to W (📐) to increase the number of image thumbnails displayed: 4 → 9 → 16. Rotate the zoom control to W (📐) in the 16-image thumbnail display to apply the calendar display (📖 87), and images can be found by the date on which they were captured. Rotate the zoom control to T (📐) to return to thumbnail display.	–
Decrease the number of images displayed	T (📐)	Rotate the zoom control to T (📐) to decrease the number of image thumbnails displayed: 16 → 9 → 4. Rotate the zoom control to T (📐) in 4-image thumbnail display to return to full-frame playback mode.	–
Delete images		Select a deletion method and delete images. When using favorite pictures mode (📖 92) or auto sort mode (📖 100), images in the same album or category can be deleted.	29
Switch to full-frame playback mode		Press the button.	80
Switch to shooting mode		Press the button or shutter-release button. The (movie-record) button can also be used to switch to shooting mode.	28

Viewing Multiple Images: Thumbnail Playback

Thumbnail Playback Mode Display

When images marked using **Print set** (📖 109) or **Protect** (📖 114) are selected, the icons shown on the right are displayed with them.

The icon shown on the right is displayed when an image in a sequence (📖 83) is selected.

Movies are displayed as film frames.

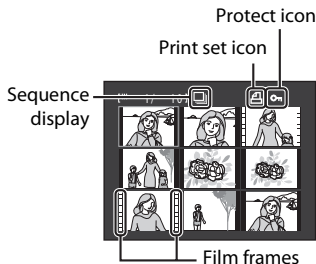

Thumbnail Display in Favorite Pictures Mode and Auto Sort Mode

- When thumbnails are displayed in favorite pictures mode (📖 92), the icon of the album being played back is displayed at the top right of the monitor.
- In auto sort mode (📖 100), the current image's category icon is displayed at the top right of the monitor.

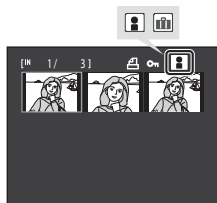

Calendar Display

With playback display of 16 thumbnails (📖 85), rotate the zoom control to **W** (📷) to switch to calendar display.

Images can be selected for display based on the date on which they were captured. The dates on which images were captured are underlined in yellow.

The following operations are available in calendar display.



Function	Control	Description	📖
Select date		Rotate the rotary multi selector, or press ▲, ▼, ◀, or ▶.	9
Return to full-frame playback		The first image captured on the selected date is displayed full frame.	80
Return to thumbnail display	T (📷)	Rotate the zoom control to T (📷).	85

✔ Notes on Calendar Display

- Images captured when the camera's date is not set are treated as images captured on January 1, 2010.
- The 🗑️ button and MENU button are not available in calendar display.

📷 List by Date Mode

Only the images captured on the same date can be played back in list by date mode (📖 104). The list by date options (📖 106) are also available only for the images captured on the selected dates.

Taking a Closer Look: Playback Zoom

Rotating the zoom control to **T** (Q) in full-frame playback mode (📖 80) enlarges display of the center portion of the current image.

- The guide displayed at bottom right shows the portion of the image currently displayed.

The following operations are available while image display is enlarged.

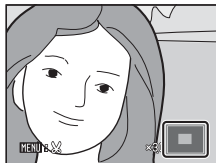

Function	Control	Description	📖
Zoom in	T (Q)	Zoom increases each time the zoom control is rotated to T (Q), up to about 10x.	–
Zoom out	W (Q)	Zoom decreases each time the zoom control is rotated to W (Q). When the magnification ratio reaches 1x, the display returns to full-frame playback mode.	–
View other areas of image		Press the rotary multi selector ▲, ▼, ◀, or ▶ to move the display area to other areas of the image.	9
Delete images		Select a deletion method and delete images. When using favorite pictures mode (📖 92), auto sort mode (📖 100), or list by date mode (📖 104), images in the same album, category, or shooting date can be deleted.	29
Switch to full-frame playback mode		Press the button.	80
Crop image	MENU	Create a cropped copy with only the enlarged portion and save the copy as a separate file.	128
Switch to shooting mode		Press the button or shutter-release button. The (movie-record) button can also be used to switch to shooting mode.	28

Images Captured with Face Detection





When zooming in (playback zoom) on an image captured using face detection (📖 52) by rotating the zoom control to **T** (📷) in full-frame playback mode, the image will be enlarged with the face detected with shooting at the center of the monitor (except images captured with continuous shooting mode (📖 73)).



- If more than one face was detected, the image will be enlarged with the face on which focus was acquired at the center of the monitor. Press the rotary multi selector ▲, ▼, ◀, or ▶ to display other detected faces.
- Rotate the zoom control toward **T** (📷) again or toward **W** (📐) to zoom in or out as normal.

Playing Back Images by Category

The following playback modes can be selected.

	Play 📖 80
Play back all images.	
	Favorite pictures 📖 92
Play back images added to an album.	
	Auto sort 📖 100
Play back images and movies automatically sorted to the selected category with shooting.	
	List by date 📖 104
Play back images captured on the selected date.	

1 Press the **MENU** button in playback mode.

The playback menu is displayed.

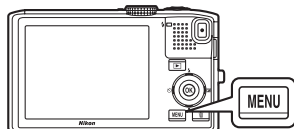

2 Press the rotary multi selector ◀.

Tab selection is activated.

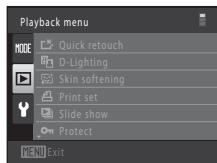

3 Press ▲ or ▼ to choose the **MODE** tab.

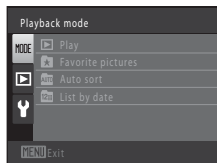

4 Press ▶ or the **OK** button.

The playback-mode selection menu is displayed.

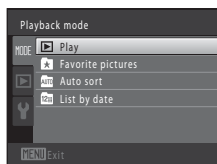

5 Use the rotary multi selector to choose a playback mode.

To return to the current playback mode without switching playback modes, press the **MENU** button.

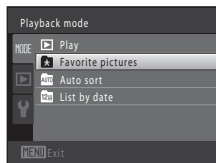

6 Press the **OK** button.

The camera enters the selected playback mode.

Sorting Favorite Images (Favorite Pictures Mode)



Captured images can be added to an album and sorted.

After images are added, they can be easily played back using “ favorite pictures mode.”

- By adding images to an album, images can be easily found.
- Images can be sorted by each event such as vacations or weddings.
- The same image can be added to multiple albums.



Adding Images to an Album

Captured images can be added to an album and sorted.

- 1 Choose an image in playback mode ( 28), auto sort mode ( 100), or list by date mode ( 104) and press the **MENU** button.

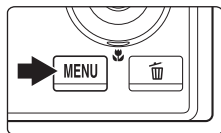



The playback menu is displayed.



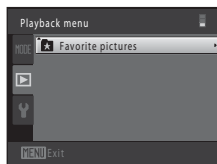

- 2 Use the rotary multi selector to choose  **Favorite pictures** and press the  button.

The favorite pictures screen is displayed.



- 3 Rotate the rotary multi selector or press  or , and then choose an image and press  to display .

To add more images to the same album, repeat this step as necessary.

To undo the selection, press  to remove .

Rotate the zoom control ( 4) to **T** () to switch back to full-frame playback or **W** () to display thumbnails.

Press the  button to display the album selection screen.

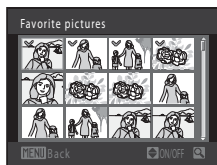



- 4** Use the rotary multi selector to choose the album to which the images will be added and press the **OK** button.

The selected images are added and the camera switches to the playback menu.

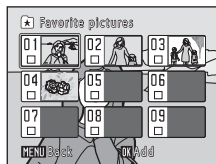
To add the same image to multiple albums, repeat from step 3.



Notes on Favorite Pictures

- Up to 200 images can be added to each album.
- Movies cannot be added to an album.
- If the selected image has been already added to an album,  is displayed in the album's checkbox.
- When images are added to an album, they are not moved from the folder to which they were saved ( 185) or copied to the album ( 99).

More Information

See "Removing Images From an Album" ( 95).

Viewing Images in an Album

When using “ favorite pictures mode”, images added to an album can be displayed by selecting the album.

- In full-frame playback mode, images in the same album can be played back (80) and edited (122).
- When the **MENU** button is pressed in full-frame playback mode or thumbnail display mode, the favorite pictures menu (96) is displayed, and all images added to an album can be selected for viewing in a slide show, or applying print order or protection settings.

- 1 Press the **MENU** button during playback, select the **MODE** (playback mode) tab, and then press or the button (90).

The playback-mode selection menu is displayed.

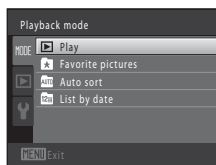
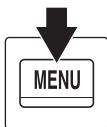

- 2 Use the rotary multi selector to choose , and press the button.

A list of albums is displayed.

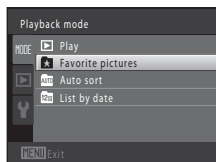

- 3 Use the rotary multi selector to choose an album.

For information about operating the list of albums screen, see 96.

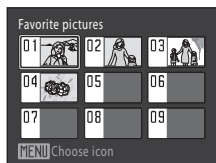

When the button is pressed, an image in the selected album is displayed full frame.

The icon of the album currently being played back is displayed at the top right of the monitor.

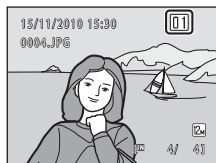

Removing Images From an Album

Remove images from an album without deleting the images.

- 1 Select the album from which images will be removed, play back images in that album (📖 94), and then press the **MENU** button.

The playback menu is displayed.

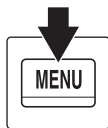
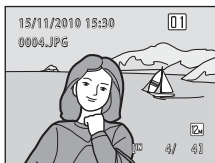

- 2 Use the rotary multi selector to choose **Remove from favorites** and press the **OK** button.

The remove from favorites screen is displayed.

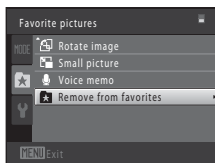

- 3 Rotate the rotary multi selector or press **◀** or **▶**, and then choose an image and press **▲** to display **✔**.

To remove more images from the same album, repeat this step as necessary.

To undo the selection, press **▼** to remove **✔**.

Rotate the zoom control (📖 4) to **T** (🔍) to switch back to full-frame playback or **W** (🖼️) to display thumbnails.

Press the **OK** button when selection is complete.



- 4 Choose **Yes** and press the **OK** button.

The image is removed from the album.

To cancel removal, select **No**.

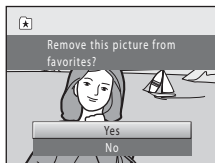









✔ Note on Deletion

If an image is deleted while using favorite pictures mode, the image will be removed from the album and it will be permanently deleted from the internal memory or the memory card (📖 99).

Using Favorite Pictures Mode

The following operations are available from the list of albums screen (📖 94 step 3).

Function	Control	Description	📖
Choose an album		Rotate the rotary multi selector, or press ▲, ▼, ◀, or ▶.	9
Switch to full-frame playback mode		Images in the selected album are displayed full frame.	80
Delete images		All images added to the selected album are deleted. Choose Yes when the confirmation dialog is displayed.	29
Change the album icon	MENU	Change the album icon.	97
Switch to shooting mode		Press the  button or shutter-release button. The  (movie-record) button can also be used to switch to shooting mode.	28
			
			

More on Playback

Favorite Pictures Menu

Press the **MENU** button in full-frame playback mode or thumbnail playback mode in favorite pictures mode to apply the following menu operations.

Quick retouch	→📖 124	D-Lighting	→📖 125
Skin softening	→📖 126	Print set	→📖 109
Slide show	→📖 113	Protect	→📖 114
Rotate image	→📖 116	Small picture	→📖 127
Voice memo	→📖 117	Remove from favorites	→📖 95

Changing the Album Icons

The design of the album icons can be changed. By changing the icons, it will be easier to identify what kind of images are added to each album.

- 1 Press the **MENU** button during playback, choose the **MODE** (playback mode) tab, and then press **▶** or the **OK** button (📖 90).

The playback-mode selection menu is displayed.

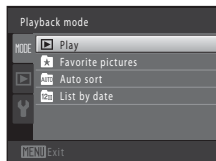
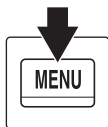

- 2 Use the rotary multi selector to choose **★**, and press the **OK** button.

A list of albums is displayed.

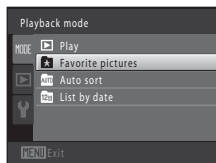

- 3 Use the rotary multi selector to choose an album and press the **MENU** button.

The choose icon screen is displayed.

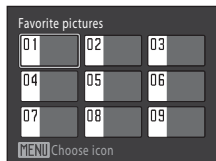
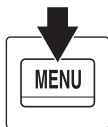

- 4 Press **◀** or **▶** to choose an icon color and press the **OK** button.

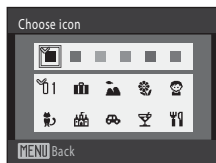

- 5 Press **▲**, **▼**, **◀**, or **▶** to choose an icon and press the **OK** button.

The icon changes and the monitor display returns to the list of albums screen.

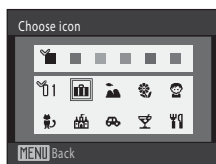

Notes on Album Icons

Set the album icons separately for the internal memory and for the memory card.

- To change the album icons for the internal memory, first remove the memory card from the camera.
- The default setting for the icon is the number icon (black).

Adding/Playing Favorite Pictures

When images are added to an album, they are not moved from the folder to which they were saved (📖 185) or copied to the album. Only the file names of the images are added to the album. When using favorite pictures mode, images are played back by retrieving the images that correspond to the file names added to the albums.

Note that if an image is deleted while using favorite pictures mode (📖 29, 96), the image will be removed from the album and it will be permanently deleted from the internal memory or the memory card.

Adding Pictures to Albums

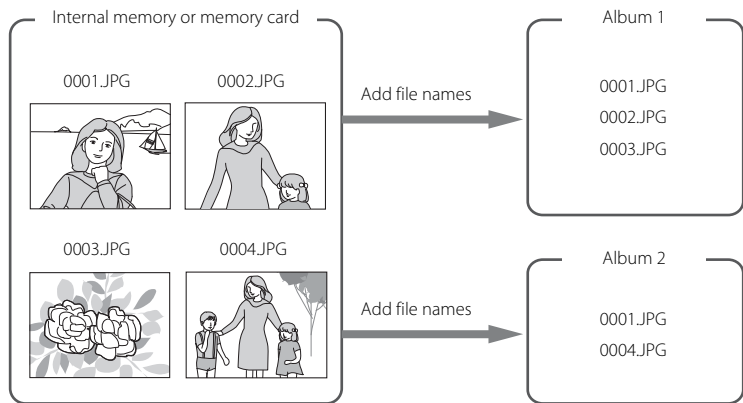





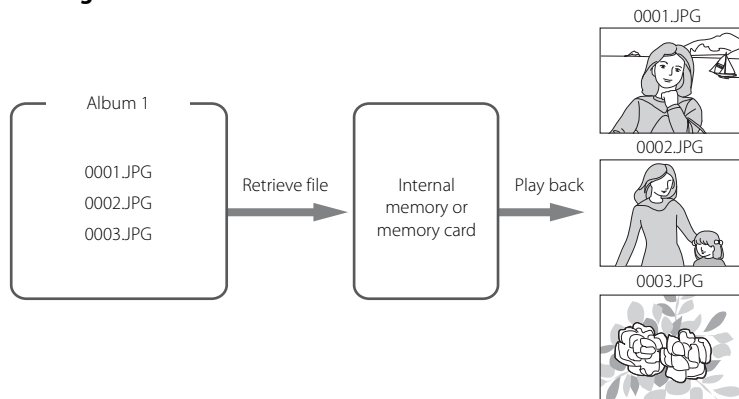



More on Playback

Viewing Pictures in Albums



Finding Images in Auto Sort Mode

Images and movies are automatically sorted to any of the following categories with shooting. When “**AUTO** auto sort mode” is selected, images and movies can be viewed by selecting the category to which they were sorted.

 Smile	 Portraits	 Food
 Landscape	 Dusk to dawn	 Close-ups
 Movie	 Retouched copies	 Other scenes

- In full-frame playback mode, images in the same category can be played back (📖 80) and edited (📖 122). Images can be also sorted into albums.
- When the **MENU** button is pressed, the auto sort menu (📖 103) is displayed, and all images in the same category can be selected for viewing in a slide show, or applying print order or protection settings.

Viewing Images in Auto Sort Mode

- 1** Press the **MENU** button during playback, choose the **MODE** (playback mode) tab, and then press **▶** or the **OK** button (📖 90).

The playback-mode selection menu is displayed.

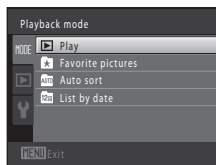
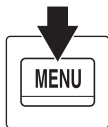

- 2** Use the rotary multi selector to choose **AUTO**, and press the **OK** button.

A list of categories is displayed.

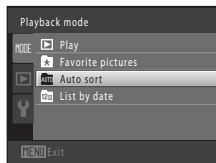

3 Use the rotary multi selector to choose a desired category.

For information about categories, see “Auto Sort Mode Categories” (📖 102).







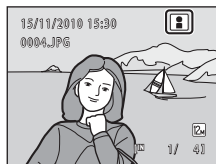







For information about operating the auto sort mode screen, see “Operations in Auto Sort Mode” (📖 103).

Press the  button to display an image in the selected category in full-frame playback mode.

The icon of the category currently played back will be displayed at the top right of the screen.



Auto Sort Mode Categories

Category	Description
 Smile	Images captured using smile timer (📖 34).
 Portraits	Images captured in  (auto) mode (📖 22) and continuous shooting mode (📖 73) using face detection (📖 52). Images captured in the following scene modes. <ul style="list-style-type: none"> •  (night portrait)* (📖 59) •  (backlighting)* (📖 60) • Portrait* (📖 61), Party/indoor (📖 62)
 Food	Images captured in the Food (📖 65) scene mode.
 Landscape	Images captured in the Landscape* (📖 61) scene mode.
 Dusk to dawn	Images captured in the following scene modes. <ul style="list-style-type: none"> •  (night landscape)* (📖 58) • Sunset (📖 63), Dusk/dawn (📖 63), Fireworks show (📖 66)
 Close-ups	Images captured in  (auto) mode and continuous shooting mode (📖 73) with macro mode set (📖 36). Images captured in the Close-up* (📖 64) scene mode.
 Movie	Movies (📖 129).
 Retouched copies	Copies created using editing function (📖 122).
 Other scenes	All other images that cannot be defined by the categories described above.







* Images captured in scene auto selector (📖 56) are also sorted to the appropriate categories.

Notes on Auto Sort Mode

- Up to 999 images and movie files can be sorted to each category in auto sort mode. If 999 images or movies have already been sorted to a specific category, new images and movies cannot be sorted to that category nor can they be displayed in auto sort mode. Display images and movies that could not be sorted to a category in normal playback mode (📖 28) or list by date mode (📖 104).
- Images or movies copied from the internal memory to a memory card, or vice versa (📖 119), cannot be displayed in auto sort mode.
- Images or movies saved by a camera other than the COOLPIX S8100 cannot be displayed in auto sort mode.

Operations in Auto Sort Mode

The following operations are available in the category list screen (📖 101 step 3).

Function	Control	Description	📖
Select a category		Rotate the rotary multi selector, or press ▲, ▼, ◀, or ▶.	9
Switch to full-frame playback mode		Display images in the selected category in full-frame playback mode.	80
Delete images		Delete all images in the selected category. Choose Yes when the confirmation dialog is displayed.	29
Switch to shooting mode		Press the  button or shutter-release button. The ● (movie-record) button can also be used to switch to shooting mode.	28
			
			

More on Playback

Auto Sort Menu

Press the **MENU** button in full-frame playback mode or thumbnail playback mode in auto sort mode to operate the following menus.



Quick retouch	→📖 124	D-Lighting	→📖 125
Skin softening	→📖 126	Print set	→📖 109
Slide show	→📖 113	Protect	→📖 114
Rotate image	→📖 116	Small picture	→📖 127
Voice memo	→📖 117	Favorite pictures	→📖 92

Viewing Images by Date (List by Date)

In “ list by date mode”, only images captured on the same date can be played back.

- In full-frame playback mode, just as with normal playback mode, shooting information can be displayed, image display can be enlarged, images can be edited, and movies can be played back. Images can be also sorted into albums.
- When the **MENU** button is pressed, the list by date menu ( 106) is displayed, and all images captured on the same date can be selected for viewing in a slide show, or applying print order or protection settings.

Viewing Images in List by Date Mode

- 1 Press the **MENU** button during playback, choose the **MODE** (playback mode) tab, and then press  or the **OK** button ( 90).

The playback-mode selection menu is displayed.

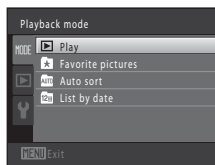
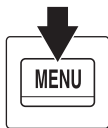

- 2 Use the rotary multi selector to choose , and press the **OK** button.

The list by date screen is displayed.

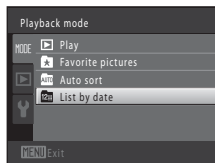

- 3 Use the rotary multi selector to choose a date.

The camera lists up to 29 dates. If images exist for more than 29 dates, all images saved earlier than most recent 29 dates will be combined under **Others**.

For information about operating the list by date screen, see “Operations in List by Date Mode” ( 106).

When the **OK** button is pressed, the first image captured on the selected date will be displayed full frame.

Rotate the zoom control to **W** () in full-frame playback mode or while displaying shooting information to return to the list by date screen.

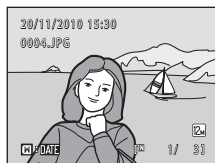
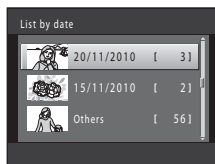







Notes on List by Date Mode

- The 9,000 most recent images can be displayed in list by date mode. If more than 9,000 images are saved, “*” is displayed for the date containing the 9,001st image.
- Images captured when the camera’s date is not set are treated as images captured on January 1, 2010.

Operations in List by Date Mode

The following operations are available in the list by date screen (📖 104 step 3).

Function	Control	Description	📖
Select date		Rotate the rotary multi selector, or press ▲ or ▼.	9
Switch to full-frame playback mode		Display images captured on the selected date in full-frame playback mode. Rotate the zoom control to W (📐) while in full-frame playback mode to return to the list by date screen.	80
Delete images		Delete all images captured on the selected date. Choose Yes when the confirmation dialog is displayed.	29
View list by date menu	MENU	Press the MENU button to display the list by date menu.	–
Switch to shooting mode		Press the  button or shutter-release button. The ● (movie-record) button can also be used to switch to shooting mode.	28
			
			

List by Date Menu

Press the **MENU** button in list by date mode to apply one of the following menu operations to images captured on the selected date.





























Quick retouch ¹	→📖 124	D-Lighting ¹	→📖 125
Skin softening ¹	→📖 126	Print set ²	→📖 109
Slide show	→📖 113	Protect ²	→📖 114
Rotate image ¹	→📖 116	Small picture ¹	→📖 127
Voice memo ¹	→📖 117	Favorite pictures ¹	→📖 92

¹ After displaying the image in full-frame playback mode, press the **MENU** button.

² When the **MENU** button is pressed in the list by date screen (📖 104 step 3), options can be applied to all images captured on the selected date. When the **MENU** button is pressed in full-frame playback mode, options can be applied to individual images.

Playback Options: Playback Menu

The following options are available in the playback menu.

 Quick retouch  124	Easily create retouched copies in which contrast and saturation have been enhanced.
 D-Lighting  125	Enhance brightness and contrast in dark portions of images.
 Skin softening  126	Make facial skin tones softer.
 Print set  109	Select images to print and the number of copies for each.
 Slide show  113	View images saved in the internal memory or on a memory card in an automatic slide show.
 Protect  114	Protect selected images from accidental deletion.
 Rotate image  116	Change the orientation of images.
 Small picture  127	Create a small copy of the current image.
 Voice memo  117	Record voice memos for images.
 Copy  119	Copy files between the internal memory and a memory card.
 Sequence display options  121	Display a sequence of images shot continuously as individual images, or display only the key picture of a sequence.
 Choose key picture  121	Change the key picture that is displayed to represent a series of images shot continuously (sequence →  83).
 Favorite pictures  92	Select and add images as favorites.
 Remove from favorites  95	Remove an image from an album.

Displaying the Playback Menu

Press the **▶** button to enter playback mode (📖 80).

Press the **MENU** button to display the playback menu.

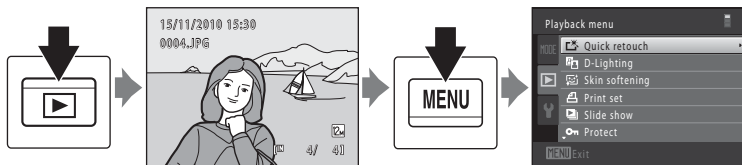

- Use the rotary multi selector to choose and apply settings (📖 9).
- Press the **MENU** button to exit the playback menu.
- Select the **MODE** (playback mode) tab to switch the playback mode (📖 90).

Print Set (Creating a DPOF Print Order)

▶ button (Playback mode) → MENU (Playback menu) → Print set

When printing images saved on the memory card using any of the following methods, the **Print set** option in the playback menu is used to create digital “print orders” for printing on DPOF-compatible devices.

- Inserting the memory card into a DPOF-compatible (📖 201) printer’s card slot
- Taking the memory card to a digital photo lab.
- Connecting the camera to a PictBridge-compatible (📖 201) printer (📖 151). A print order can also be created for images saved in the internal memory if the memory card is removed from the camera.

1 Press the MENU button in playback mode.

The playback menu is displayed.

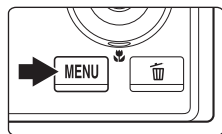

2 Use the rotary multi selector to choose **Print set** and press the **OK** button.

Proceed to step 4 when playing back in favorite pictures mode, auto sort mode, or list by date mode.

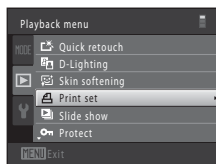

3 Choose **Select images** and press the **OK** button.

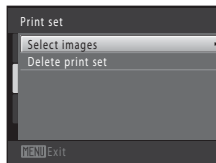

4 Choose images (up to 99) and the number of copies (up to nine) of each.

Rotate the rotary multi selector, or press ◀ or ▶ to select images, and press ▲ or ▼ to specify the number of copies to be printed.

Image selected for printing can be identified by the check mark (✓) and the numeral indicating the number of copies to be printed. If no copies have been specified for images, the selection is canceled.

Rotate the zoom control to **T** (Q) to switch to full-frame playback. Rotate the zoom control to **W** (E) to switch back to 12-thumbnail display.

Press the **OK** button when setting is complete.





5 Choose whether or not to print shooting date and photo information.

Choose **Date** and press the **OK** button to print the shooting date on all images.

Choose **Info** and press the **OK** button to print shooting data (shutter speed and aperture) on all images.

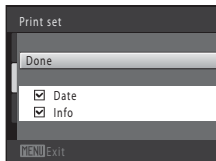
Choose **Done** and press the **OK** button to apply the settings.



Images selected for printing can be identified by the  icon displayed with playback.

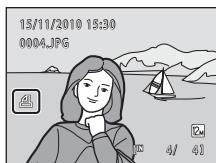

✓ Notes on Print Set

When a print order is created in favorite pictures mode, auto sort mode, or list by date mode, the screen shown below is displayed if images other than those in the selected album, category, or shooting date have been marked for printing.

- If **Yes** is selected, the current print order settings are added to the print order settings of other images.
- If **No** is selected, all print order settings of other images are removed and only the current print order settings remain.

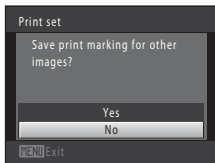

Favorite pictures mode
or auto sort mode

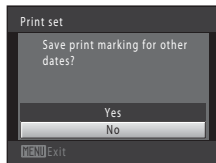

List by date mode

Additionally, if there are more than 99 images as a result of adding the current print order settings, the screen shown below will be displayed.

- If **Yes** is selected, all print order settings of other images are removed and only the current print order settings remain.
- If **Cancel** is selected, the print order settings of other images remain and the current print order settings are removed.

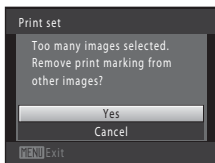

Favorite pictures mode
or auto sort mode

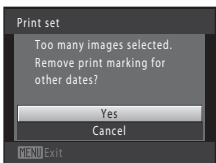

List by date mode

✔ Notes on Printing Shooting Date and Photo Information

When the **Date** and **Info** settings are enabled in the print set option, shooting date and shooting data are printed on images when a DPOF-compatible (📖 201) printer that supports printing of shooting date and shooting data is used.

- Shooting data cannot be printed when the camera is connected directly to a printer, via the supplied USB cable, for DPOF printing (📖 156).
- Note that **Date** and **Info** settings are reset each time the **Print set** option is displayed.
- The date printed is that saved when the image was captured. Changing the camera's date using the **Date** option in the setup menu after an image has been captured has no effect on the date printed on the image.



✂ Canceling Existing Print Order

Select **Delete print set** in step 3 of "Print Set (Creating a DPOF Print Order)" (📖 109) and press the **OK** button to remove print marking from all images and cancel the print order.

👤 Date Imprint

When shooting date and time are imprinted on images using the **Date imprint** option (📖 165) in setup menu, images are saved with shooting date and time imprinted on the image when they are captured. Images with the date imprinted on them can be printed from printers that do not support printing of the date on images.

Only the **Date imprint** date and time on images will be printed, even if **Print set** is enabled with **Date** selected in the print set screen.

Slide Show

 button (Playback mode) → MENU (Playback menu) →  Slide show

Play back images, saved in the internal memory or on a memory card, one by one in an automated “slide show.”



1 Use the rotary multi selector to choose **Start** and press the **OK** button.

To change the interval between images, choose **Frame intvl**, select the desired interval time, and press the **OK** button before choosing **Start**.

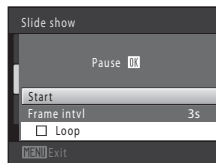
To repeat the slide show automatically, choose **Loop** and press the **OK** button before choosing **Start**. The check mark (✓) will be added to the loop option when enabled.



2 The slide show begins.

While the slide show is in progress, press the rotary multi selector  to display the next image or  to display the previous image. Hold down either button to fast forward or rewind.

To end or pause the slide show, press the **OK** button.



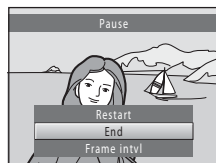

3 End the slide show or restart it.

The screen shown on the right is displayed when the slide show has ended or is paused. Choose **End** and press the **OK** button to return to the playback menu. Choose **Restart** to play the slide show again.



Notes on Slide Show

- Only the first frame of movies is displayed.
- For sequences ( 83) whose sequence display options are set to **Key picture only**, only the key picture is displayed.
- The maximum playback time is up to 30 minutes even if **Loop** is enabled ( 171).

Protect

 button (Playback mode) → MENU (Playback menu) →  Protect

Protect selected images from accidental deletion.

Select images to protect or cancel protection for previously protected images from the image selection screen. See “Selecting Images” ( 115) for more information.

Note that formatting the camera’s internal memory or the memory card will permanently delete protected images ( 172).

Protected images can be identified by the  icon in playback mode ( 7, 86).

Selecting Images

When using one of the following features, a screen like that shown on the right is displayed when selecting images.

- Print set > **Select images** (📖 109)
- Protect (📖 114)
- Rotate image (📖 116)
- Copy > **Selected images** (📖 119)
- Choose key picture (📖 121)
- Favorite pictures (📖 92)
- Remove from favorites (📖 95)
- Welcome screen > **Select an image** (📖 159)
- Delete image > **Erase selected images** (📖 29)



Follow the procedures described below to choose the images.

1 Rotate the rotary multi selector, or press ◀ or ▶ to choose the desired image.

Rotate the zoom control (📖 4) to **T** (🔍) to switch to full-frame playback or **W** (📐) to switch back to 12-thumbnail display.

Only one image can be selected for **Rotate image**, **Choose key picture**, and **Welcome screen**. Proceed to step 3.



2 Press ▲ or ▼ to select or deselect (or to specify the number of copies).



When an image is selected, a check mark (☑) is displayed with the image. Repeat steps 1 and 2 to select additional images.



3 Press the Ⓞ button to apply image selection.

When **Selected images** is selected, a confirmation dialog is displayed. Follow the instructions displayed in the monitor.

Rotate Image

 button (Playback mode) → MENU (Playback menu) →  Rotate image

Specify the orientation in which saved images are displayed with playback. Still images can be rotated 90 degrees clockwise or 90 degrees counterclockwise. Images that were saved in portrait (“tall”) orientation can be rotated up to 180 degrees in either direction.

Select an image from the image selection screen ( 115). When the Rotate image screen is displayed, rotate the rotary multi selector or press ◀ or ▶ to rotate the image 90 degrees.

More on Playback

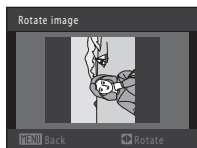

Rotate 90 degrees
counterclockwise

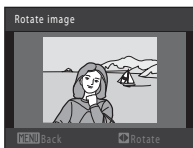

Rotate 90 degrees
clockwise





Press the  button to finalize display orientation, and save orientation information with the image.

Rotating Images in a Sequence



While the key picture of a sequence is displayed, images cannot be rotated. Apply the setting after displaying individual images ( 83, 121).

Voice Memo

 button (Playback mode) → MENU (Playback menu) →  Voice memo

Use the camera's microphone to record voice memos for images.

Recording Voice Memos

- 1 Choose an image in full-frame playback mode ( 80) or thumbnail playback mode ( 85) and press the **MENU** button.

The playback menu is displayed.

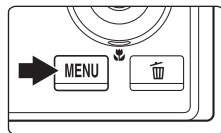

- 2 Use the rotary multi selector to choose  **Voice memo** and press the **OK** button.

The screen for recording voice memos is displayed.

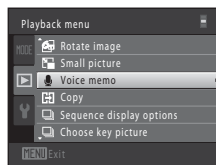

- 3 Press and hold the **OK** button to record a voice memo.

Recording ends after about 20 seconds or when the **OK** button is released.

Do not touch the microphone during recording.

During recording, **REC** and  blink in the monitor.

When recording ends, the voice memo playback screen is displayed. Follow the procedure in step 3 of "Playing Voice Memos" ( 118) to play the voice memo.

Press the rotary multi selector  before or after recording a voice memo to return to the playback menu. Press the **MENU** button to exit the playback menu.

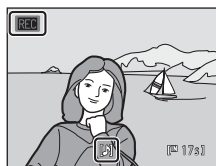



More Information

See "Image/Sound File and Folder Names" ( 185) for more information.

Playing Voice Memos

Images for which voice memos have been recorded are indicated by  in full-frame playback mode.

- 1 Choose an image in full-frame playback mode ( 80) or thumbnail playback mode ( 85) and press the **MENU** button.

The playback menu is displayed.

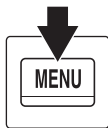

- 2 Use the rotary multi selector to choose  **Voice memo** and press the **OK** button.

The voice memo playback screen is displayed.

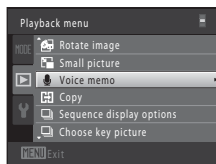

- 3 Press the **OK** button to play the voice memo.







Press the **OK** button again to stop playback.

Rotate the zoom control to **T** or **W** during playback to adjust playback volume.

Press the rotary multi selector  before or after playing a voice memo to return to the playback menu. Press the **MENU** button to exit the playback menu.



Deleting Voice Memos

Select an image with a voice memo and press the  button. Rotate the rotary multi selector or press  or  to choose **Current image**, and press the **OK** button ( 29). When the confirmation dialog is displayed, press the rotary multi selector  or  to choose  and press the **OK** button. Only the voice memo will be deleted.



Notes on Voice Memos



- When an image with a voice memo attached is deleted, both the image and its voice memo are deleted.
- Voice memos cannot be recorded for an image that already has a voice memo attached on it. The current voice memo must be deleted before a new voice memo can be recorded.
- The COOLPIX S8100 is not able to record a voice memo for images captured with another make or model of digital camera.

Copy (Copy Between Internal Memory and Memory Card)

 button (Playback mode) → MENU (Playback menu) →  Copy

Copy images between the internal memory and a memory card.



- 1 Use the rotary multi selector to choose a destination option to which images are copied and press the  button.

 → : Copy images from internal memory to memory card.

 → : Copy images from memory card to internal memory.



- 2 Select a copy option and press the  button.







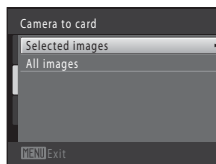



Selected images: Copy images selected from the image selection screen ( 115). If a sequence for which only a key picture is displayed is selected ( 83), all images in the displayed sequence are copied.

All images: Copy all images. If an image in a sequence is selected, this option is not displayed.

Current sequence: If an image in a sequence is selected, this option is displayed. All images in the current sequence are copied.



Notes on Copying Images

- JPEG-, MOV-, and WAV-format files can be copied. Files saved in any other format cannot be copied.
- If voice memos ( 117) are attached to images selected for copying, voice memos are copied with the images.
- Operation is not guaranteed with images captured with another make of camera or that have been modified on a computer.
- When copying images for which **Print set** ( 109) options are enabled, the print set settings are not copied. However, when copying images for which **Protect** ( 114) is enabled, the protect setting is copied.
- Images or movies copied from the internal memory or a memory card cannot be displayed in auto sort mode ( 100).
- Even if images added to an album ( 92) are copied, the contents of the album will not be copied.
- If **Sequence display options** ( 121) is set to **Key picture only** and an image in the sequence is selected and the  button is pressed to display individual images ( 83), only    (memory card to internal memory) image copy is available.



Memory contains no images. Message



If there are no images saved on a memory card inserted in the camera when playback mode is applied, the message **Memory contains no images.** will be displayed. Press the **MENU** button to display the copy option screen, and copy the images saved in the camera's internal memory to the memory card.

More Information

See "Image/Sound File and Folder Names" ( 185) for more information.

Sequence Display Options

 button (Playback mode) → MENU (Playback menu) →  Sequence display options

Choose the method used to display a series of images shot continuously (sequence →  83) when viewing them in full-frame playback mode ( 80) and in thumbnail playback mode ( 85).

Settings are applied to all sequences, and the setting is saved in the camera's memory even if the camera is turned off.

Individual pictures



Each image in a sequence is displayed.

Key picture only (default setting)

Return a sequence in which images are displayed individually to the key picture only display.

Choose Key Picture

 button (Playback mode) → MENU (Playback menu) →  Choose key picture

When **Sequence display options** is set to **Key picture only**, the key picture displayed in full-frame playback mode ( 80) or thumbnail playback mode ( 85) can be set for each sequence of images.

- When changing this setting, before pressing **MENU**, first select the desired sequence using full-frame playback mode or thumbnail playback mode.
- When the key picture selection screen is displayed, select an image. See “Selecting Images” ( 115) for more information.

Editing Functions

Use the COOLPIX S8100 to edit images in-camera and save them as separate files (📖 185). The editing functions described below are available.

Editing function	Description
Quick retouch (📖 124)	Easily create retouched copies in which contrast and saturation have been enhanced.
D-Lighting (📖 125)	Create a copy of the current image with enhanced brightness and contrast, brightening dark portions of the image.
Skin softening (📖 126)	Make facial skin tones softer.
Small picture (📖 127)	Create a small copy of images suitable for use as e-mail attachments.
Crop (📖 128)	Crop a portion of the image. Use to zoom in on a subject or arrange a composition.

✓ Notes on Image Editing

- Images captured at an **Image mode** setting of **3968 × 2232** (📖 44) cannot be edited. Still images captured while recording high-definition or full high-definition movies also cannot be edited (📖 131).
- The editing functions of the COOLPIX S8100 cannot be used for images captured with another make or model of digital cameras.
- If no face is detected in an image, a copy cannot be created using the skin softening function (📖 126).
- Edited copies created with the COOLPIX S8100 may not be displayed properly on another make or model of digital camera. It may also be impossible to transfer them to a computer using another make or model of digital camera.
- Editing functions are not available when there is not enough free space in the internal memory or on the memory card.
- For sequences for which only a key picture is displayed (📖 83), perform one of the following operations before editing.
 - Press **OK** button to display individual images, and then select an image in the sequence
 - Set **Sequence display options** (📖 121) to **Individual pictures** so that each image is displayed individually, and then select an image

Restrictions on Image Editing

When an edited copy is further modified with another editing function, check the following restrictions.

Editing function used	Editing function to add
Quick retouch D-Lighting	The skin softening, small picture, or crop function can be added. The quick retouch and D-Lighting functions cannot be used together.
Skin softening	The quick retouch, D-Lighting, small picture, or crop function can be added.
Small picture Crop	Another editing function cannot be added.

- Copies created with editing functions cannot be further edited with the same function used to create them.
- When combining the small picture or crop function and another editing function, use the small picture and crop functions after other editing functions have been applied.

Original and Edited Images





- Copies created with editing functions are not deleted if the original images are deleted. The original images are not deleted if copies created with editing functions are deleted.
- Edited copies are saved with the same shooting date and time as the original.
- Print set ( 109) and protect settings ( 114) do not remain effective in edited copies.

Image Editing

Quick Retouch: Enhancing Contrast and Saturation

Quick retouch can be used to easily create retouched copies in which contrast and saturation have been enhanced. Copies created with the quick retouch function are saved as separate files.

- 1 Choose the desired image in full-frame playback mode ( 80) or thumbnail playback mode ( 85) and press the **MENU** button.

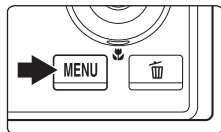

The playback menu is displayed.

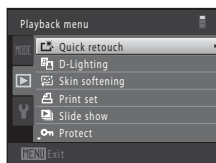

- 2 Use the rotary multi selector to choose  **Quick retouch** and press the **OK** button.

The original version is displayed on the left and the edited version is displayed on the right.



- 3 Press the rotary multi selector  or  to choose the degree of enhancement performed and press the **OK** button.

A new, edited copy is created.

To exit without saving the copy, press the **MENU** button.

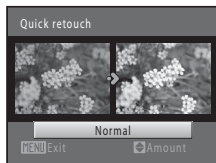

Copies created with the quick retouch function can be identified by the  icon displayed in playback mode.

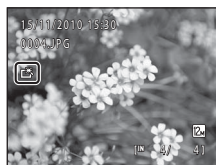



More Information

See "Image/Sound File and Folder Names" ( 185) for more information.

D-Lighting: Enhancing Brightness and Contrast

D-Lighting can be used to create copies with enhanced brightness and contrast, brightening dark portions of an image. Enhanced copies are saved as separate files.

- 1 Choose the desired image in full-frame playback mode ( 80) or thumbnail playback mode ( 85) and press the **MENU** button.

The playback menu is displayed.

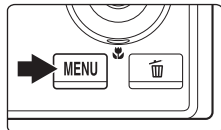

- 2 Use the rotary multi selector to choose  **D-Lighting** and press the **OK** button.

The original version is displayed on the left and the edited version is displayed on the right.

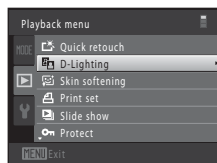

- 3 Choose **OK** and press the **OK** button.

A new, edited copy is created.

To exit without saving the copy, choose **Cancel** and press the **OK** button.

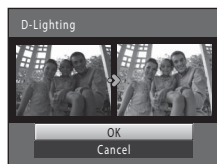

Copies created with the D-Lighting function can be identified by the  icon displayed in playback mode.



More Information

See "Image/Sound File and Folder Names" ( 185) for more information.

Skin Softening: Softening Skin Tones

The camera detects faces in images and creates a copy with softer facial skin tones. Copies created using the skin softening function are saved as separate files.

- 1 Choose the desired image in full-frame playback mode ( 80) or thumbnail playback mode ( 85) and press the **MENU** button.

The playback menu is displayed.

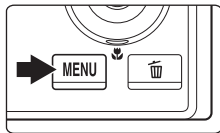

- 2 Use the rotary multi selector to choose  **Skin softening** and press the **OK** button.

The screen for selecting the degree of softening is displayed.

If no faces are detected in the image, an alert is displayed and the camera returns to the playback menu.

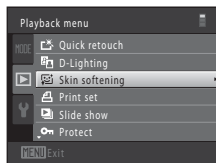

- 3 Press the rotary multi selector **▲** or **▼** to choose the degree of softening and press the **OK** button.

The confirmation dialog is displayed with the face to which skin softening was applied enlarged at the center of the monitor.

To exit without saving the copy, press the **MENU** button.

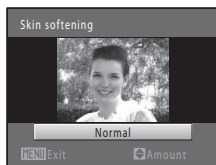

- 4 Check the preview of the copy.

Skin tones in up to 12 faces, in the order of that closest to the center of the frame, are softened.

If more than one face was softened, press the rotary multi selector **◀** or **▶** to display a different face.

Press the **MENU** button to adjust the degree of softening. The monitor display returns to that shown in step 3.

When the **OK** button is pressed, a new, edited copy is created.

Copies created with the skin softening function can be recognized by the  icon displayed in playback mode.





Note on Skin Softening



Depending upon the direction in which faces are looking, or the brightness of faces, the camera may be unable to accurately recognize faces, or the skin softening function may not perform as expected.

More Information

See "Image/Sound File and Folder Names" ( 185) for more information.

Small Picture: (Decreasing Image Size)

Create a small copy of the current image. This feature is useful for creating copies for display on Web pages or e-mail attachments. The  **640 × 480**,  **320 × 240**, and  **160 × 120** sizes are available. Small copies are saved as separate files with a compression ratio of 1:16.

- 1 Choose the desired image in full-frame playback mode ( 80) or thumbnail playback mode ( 85) and press the **MENU** button.

The playback menu is displayed.

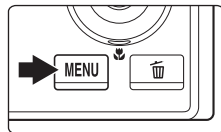

- 2 Use the rotary multi selector to choose  **Small picture** and press the **OK** button.

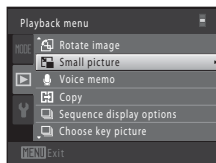

- 3 Choose the desired copy size and press the **OK** button.

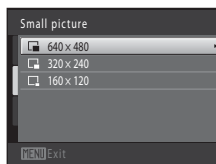

- 4 Choose **Yes** and press the **OK** button.

A new, small copy is created.

To exit without saving the copy, choose **No** and press the **OK** button.

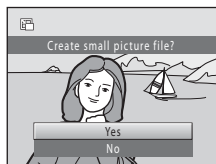

The copy is displayed with a gray frame.



More Information

See "Image/Sound File and Folder Names" ( 185) for more information.

✂ Crop: Creating a Cropped Copy

Create a copy containing only the portion visible in the monitor when **MENU**  is displayed with playback zoom ( 88) enabled. Cropped copies are saved as separate files.

1 Rotate the zoom control to **T** () in full-frame playback mode (80) to zoom in on the image.

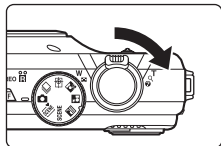

To crop an image displayed in “tall” (portrait) orientation, zoom in on the image until the black bars displayed on the both sides of the monitor disappear. The cropped image will be displayed in landscape orientation.

To crop the image in its current “tall” (portrait) orientation, first use the **Rotate image** option ( 116) to rotate the image so that it is displayed in landscape orientation. Next, enlarge the image for cropping, crop the image, and then rotate the cropped image back to “tall” (portrait) orientation.



2 Refine copy composition.

Rotate the zoom control to **T** () or **W** () to adjust the zoom ratio.

Press the rotary multi selector , , , or  to scroll the image so that only the portion to be copied is visible in the monitor.



3 Press the **MENU** button.

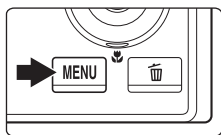



4 Use the rotary multi selector to choose **Yes** and press the **OK** button.

A cropped copy is created.

To exit without saving the copy, choose **No** and press the **OK** button.



Image Size

As the area to be saved is reduced, the image size (pixels) of the cropped copy is also reduced. When the image size of the cropped copy is 320 × 240 or 160 × 120, a gray frame is displayed around the image, and the small picture icon  or  is displayed in the left of the monitor in playback mode.

More Information

See “Image/Sound File and Folder Names” ( 185) for more information.

Recording Movies

High-definition movies with sound can be recorded.

- The maximum movie length for a single movie is 29 minutes, even when there is sufficient free space on the memory card for longer recording (📖 135).

1 Turn on the camera and be sure that it is in shooting mode.

Movies can be recorded in any shooting mode (📖 42).

The icon for the selected movie option is displayed. The default setting is  **HD 1080p★ (1920 × 1080)** (📖 134).

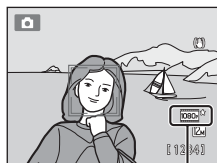

Movie option

2 Press the (movie-record) button to start movie recording.

Movie recording begins after the monitor briefly turns off.

The camera focuses at the center of the frame. Focus areas are not displayed during recording.

When recording movies in HD or Full HD, monitor display changes to an aspect ratio of 16:9 with movie recording (the area indicated at right is recorded).

The approximate remaining movie length is displayed during recording.

Recording stops automatically when the maximum movie length has been recorded.

If the shutter-release button is pressed all the way while recording, one frame is saved as a still image (📖 131).

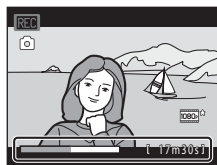

3 Press the (movie-record) button again to end recording.

Note on Saving Movies

After a movie has been recorded, it is not fully saved to the internal memory or memory card until monitor display returns to the shooting display. **Do not open the battery-chamber/memory card slot cover** before movies have been fully saved. Removing the memory card or the battery while a movie is being saved may result in loss of the movie data or damage to the camera or to the memory card.

✓ Notes on Recording Movies

- Memory cards with an SD Speed Class rating of 6 or faster are recommended when recording movies (📖 184). Movie recording may stop unexpectedly when memory cards with a lower Speed Class ratings are used.
- When recording movies, the angle of view (i.e., the area visible in the frame) is narrower compared to that of still images.
- There may be some degradation in image quality when digital zoom is used. If the digital zoom is not being used when movie recording begins, rotating and holding the zoom control at **T** zooms the image using optical zoom and the zoom stops at the maximum optical zoom ratio. After letting go of the zoom control, rotate the zoom control to **T** again to magnify the image using the digital zoom.
- When recording ends, digital zoom turns off.
- The sounds of zoom control operation, zoom, autofocus lens drive movement, vibration reduction operation, and aperture operation when brightness changes may be recorded.
- The following phenomena may be seen in the monitor while recording movies. These phenomena are saved in the recorded movies.
 - Banding may occur in images under fluorescent, mercury-vapor, or sodium-vapor lighting
 - Subjects that move quickly from one side of the frame to the other, such as a moving train or car, may appear skewed
 - The entire movie image may be skewed when the camera is panned.
 - Lighting or other bright areas may leave residual images when the camera is moved

✓ Notes on Autofocus

- When **AF Single AF** (default setting) is selected for **Autofocus mode** in movie menu, focus is locked by pressing the **●** (movie-record) button to start recording (📖 135).
- Autofocus may not perform as expected (📖 27). Should this occur, try the following:
 1. Set **Autofocus mode** in the movie menu to **AF Single AF** (default setting) before starting movie recording.
 2. Frame another subject—positioned at the same distance from the camera as the intended subject—in the center of the frame, press the **●** (movie-record) button to start recording, and then modify the composition.

✓ Camera Temperature





The camera may become warm when shooting movies for an extended period of time or when the camera is used in a hot area; this is not a malfunction.

📎 Functions Available with Movie Recording







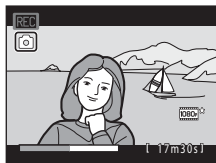

- The creative slider, white balance (when using **☑** (auto) mode, continuous shooting mode), or exposure compensation settings are also applied when recording movies. When macro mode is enabled, movies of subjects closer to the camera can be recorded. Confirm settings before starting movie recording.
- The self-timer (📖 33) can be used. If the self-timer is set and the **●** (movie-record) button is pressed, the camera focuses and starts movie recording after ten or two seconds.
- The flash will not fire.
- Press the **MENU** button to select the **📽** (movie) tab and adjust movie menu settings before starting movie recording (📖 132).

Capturing Still Images While Recording Movies

If the shutter-release button is pressed all the way while recording a movie, one frame is saved as a still image. Movie recording continues while the still image is being saved.

- A still image can be saved when  is displayed at the top left of the monitor.
-  is not displayed while saving still images. Another still image cannot be saved until  is displayed again.
- The image size of the saved still image depends on the movie type (resolution) ( 134). The compression ratio is approximately 1:8.



Movie type (resolution)	Size of still image
 HD 1080p★ (1920 × 1080)/  HD 1080p (1920 × 1080)	 (1920 × 1080)
 HD 720p (1280 × 720)	 (1280 × 720)
 VGA (640 × 480)	 (640 × 480)
 QVGA (320 × 240)	 (320 × 240)*

- Images captured at  (320 × 240) are displayed with a gray frame during playback.

Notes on Saving Still Images During Movie Recording

- When the remaining movie recording time is less than 30 seconds, still images cannot be saved.
- When recording an HS movie ( 137), still images cannot be saved.
- The shutter sound that is heard when saving a still image may be heard in the recorded movie.
- If the camera moves when the shutter-release button is pressed, the image may be blurred.

File Names of Saved Still Images

The file numbers assigned to captured still images ascend in order, starting with the file number of the movie being recorded +1.

More Information

See “Image/Sound File and Folder Names” ( 185) for more information.

Changing Movie Recording Settings

The following options can be adjusted from the movie menu.



Movie options

The camera can record normal speed movies and high speed (HS) movies, which can be played back in slow motion or fast motion.

Select **Movie** or **HS movie** according to the type of movie that should be recorded.

Option	Description
Movie (default setting)	Normal speed movies are recorded. Options for recording normal speed movies can be selected (📖 134).
HS movie	HS movies are recorded. Options for recording HS movies can be selected. → 📖 137, 139 <ul style="list-style-type: none"> • Select whether the camera records normal speed movies or HS movies (slow motion or fast motion movies) when movie recording starts.



Autofocus mode

📖 135

Select how the camera focuses during movie recording.



Wind noise reduction





📖 136

Set whether or not to reduce wind noise during movie recording.

Displaying the Movie Menu

- 1 Press the **MENU** button in shooting mode.

The menu is displayed.

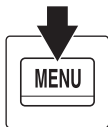

If the **MENU** button was pressed in  (scene auto selector),  (night landscape), or  (night portrait), press the rotary multi selector ( 9)  to display the tabs.



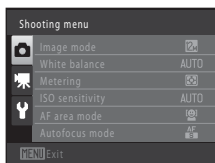

- 2 Press the rotary multi selector .

Tab selection is activated.

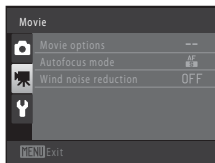

- 3 Press  or  to choose the  tab.



- 4 Press  or the  button.

The movie menu items can be selected.

Use the rotary multi selector to choose and apply settings ( 9).

To exit the movie menu, press the **MENU** button or  to select a different tab.

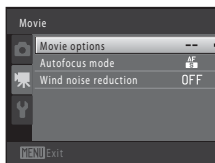







Movie of Movie Options (Normal Speed Movie Type)

Switch to shooting mode → MENU →  (Movie) ( 133) → Movie options → Movie

Select types for when recording normal speed movies.

Larger image sizes and faster movie bitrates mean greater image quality and larger movie file sizes.

- **HS movie** →  137, 139





Type	Description
 HD 1080p★ (1920 × 1080) (default setting)	Movies with an aspect ratio of 16:9 are recorded in Full HD. This option is suited to playback on a TV that supports Full HD. <ul style="list-style-type: none"> • Image size: 1920 × 1080 pixels • Movie bitrate: 14 Mbps
 HD 1080p (1920 × 1080)	Movies with an aspect ratio of 16:9 are recorded in Full HD. This option is suited to playback on a TV that supports Full HD. <ul style="list-style-type: none"> • Image size: 1920 × 1080 pixels • Movie bitrate: 12 Mbps
 HD 720p (1280 × 720)	Movies with an aspect ratio of 16:9 are recorded in high definition. This option is suited to playback on a wide screen TV. <ul style="list-style-type: none"> • Image size: 1280 × 720 pixels • Movie bitrate: 9 Mbps
 VGA (640 × 480)	Movies with an aspect ratio of 4:3 are recorded. <ul style="list-style-type: none"> • Image size: 640 × 480 pixels • Movie bitrate: 3 Mbps
 QVGA (320 × 240)	Movies with an aspect ratio of 4:3 are recorded. <ul style="list-style-type: none"> • Image size: 320 × 240 pixels • Movie bitrate: 640 kbps

- The movie bitrate is the volume of movie data recorded per second. Variable bitrate (VBR) encoding is used to automatically adjust the bitrate depending on the subject being recorded. When recording movies of subject with large amounts of motion, the file size increases.
- The frame rate is approximately 30 frames per second in any options.

More Information

See "Maximum Movie Length" ( 135) for more information.

Maximum Movie Length

Type	Internal memory (approx. 102 MB)	Memory card (4 GB)*
 HD 1080p★ (1920 × 1080) (default setting)	59 s	35 min
 HD 1080p (1920 × 1080)	1 min 9 s	40 min
 HD 720p (1280 × 720)	1 min 31 s	55 min
 VGA (640 × 480)	4 min 22 s	2 h 30 min
 QVGA (320 × 240)	18 min 7 s	11 h

All figures are approximate. The maximum movie length may vary by make of memory card.

* The maximum movie length for a single movie is 29 minutes. The maximum movie length displayed during recording is 29 minutes, even when there is enough free space on the memory card for a longer movie.



More Information

See "Image/Sound File and Folder Names" (📖 185) for more information.

Autofocus Mode

Switch to shooting mode → MENU →  (Movie) (📖 133) → Autofocus mode



Select the autofocus method used when shooting with **Movie options** in the shooting menu set to **Movie**.

Option	Description
 Single AF (default setting)	Focus is locked when the  (movie-record) button is pressed to start recording. Select this option when the distance between the camera and the subject will remain fairly consistent.
 Full-time AF	Camera focuses continuously. Select this option when the distance between the camera and subject will change significantly during recording. The sound of the camera focusing may be heard in the recorded movie. Use of Single AF is recommended to prevent the sound of the camera focusing from interfering with recording.

Autofocus Mode During Movie Recording

When using the **Fireworks show** scene mode, the camera focuses at infinity.

Wind Noise Reduction

Switch to shooting mode → MENU →  (Movie) ( 133) → Wind noise reduction

Select whether wind noise is reduced when shooting with **Movie options** in the shooting menu set to **Movie**.

Option	Description
 On	Reduces the sound heard when wind passes over the microphone. Use when recording movies in locations with strong winds. Other sounds may become difficult to hear during playback.
OFF Off (default setting)	Wind noise reduction is not enabled.

The wind noise reduction setting can be confirmed in the monitor when shooting ( 6). When **Off** is selected, an icon for the current setting is not displayed.

Recording Movies in Slow Motion and Fast Motion (HS Movie)

HS (high speed) movies can be recorded. The portions of the movie recorded using HS movie can be played back in slow motion at 1/8-1/2 of normal playback speed, or played back in fast motion at a speed two times faster than normal speed. While recording movies, the camera can be switched from normal speed movie recording to slow motion or fast motion movie recording.

- 1 Display the movie menu (📖 133), use the rotary multi selector to choose **HS movie** from **Movie options**, and then press the **OK** button.

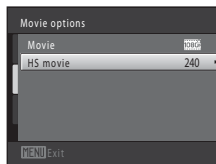

- 2 Confirm or change HS movie settings, and then press the **OK** button.

Changing HS Movie Settings (HS Movie Type) → 📖 139
Press the **MENU** button after changing the settings and return to the shooting screen.

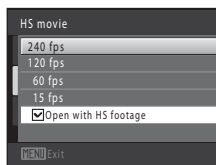

- 3 Press the **REC** (movie-record) button to start recording.

Movie recording begins after the monitor briefly turns off. The camera focuses at the center of the frame. Focus areas are not displayed during recording.

When the **Open with HS footage** checkbox is turned on, HS movies are recorded when recording begins.

When the **Open with HS footage** checkbox is turned off, normal speed movies are recorded when recording begins. Press the **OK** button to switch to HS movie recording at the point where the camera should record for slow motion or fast motion playback.

If recording time for HS movies (📖 139) runs out, or if the **OK** button is pressed, the camera switches to normal speed movie recording. The camera switches between normal speed movie recording and HS movie recording each time the **OK** button is pressed.

When recording HS movies, the maximum movie length display changes and displays the amount of recording time available for HS movie recording.

The HS movie options that are displayed change depending on the type of movie being recorded.

HS movie options

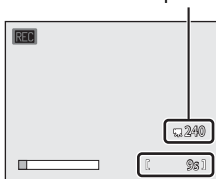

When recording HS movies

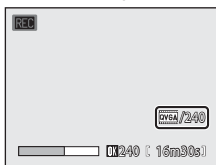

When recording normal speed movies

- 4 Press the **REC** (movie-record) button to end recording.

Recording Movies in Slow Motion and Fast Motion (HS Movie)

✓ Notes on HS Movie

- Footage recorded for slow motion or fast motion playback is not recorded with sound.
- Vibration reduction cannot be used for movies that are recorded when **Movie options** in the movie menu is set to **HS movie**. Zoom position, focus, exposure, and white balance are locked when the **(movie-record)** button is pressed to start recording.

📷 HS Movie

Recorded movies are played back at about 30 frames per second, including portions recorded using HS movie.

When **HS movie** (📖 139) is set to **240 fps**, **120 fps**, or **60 fps**, movies that can be played back in slow motion can be recorded. When set to **15 fps**, movies that can be played back in fast motion at a speed two times faster than normal speed can be recorded.

Portions recorded at 240 fps:

High-speed capturing is possible for up to ten seconds. Footage captured at high speed is played back in slow motion at a speed eight times slower than normal speed.

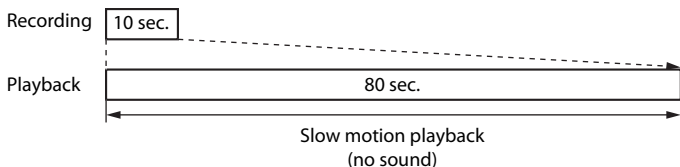

Portions recorded at 15 fps:

A movie of up to two minutes in length is recorded when shooting for the purpose of high-speed playback. Playback is two times faster.

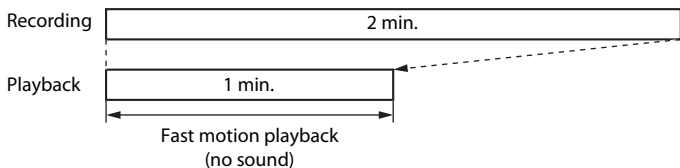

📷 Returning from HS Movie Setting to Normal Speed Movie Setting

Movie menu → **Movie options** → **Movie**, select the movie type, and press the **(OK)** button (📖 129, 134).

Changing HS Movie Settings (HS Movie Type)

Switch to shooting mode → MENU → 冫 (Movie) (133) → Movie options → HS movie

Select the type of movie recorded when **Movie options** in the movie menu is set to **HS movie**.

Option	Description
240 fps	1/8-speed slow motion movies with a 4:3 aspect ratio are recorded. <ul style="list-style-type: none"> • Max. movie length*: 10 seconds (playback time: 80 seconds) • Image size: 320 × 240 pixels • Movie bitrate: 640 kbps
120 fps	1/4-speed slow motion movies with a 4:3 aspect ratio are recorded. <ul style="list-style-type: none"> • Max. movie length*: 10 seconds (playback time: 40 seconds) • Image size: 640 × 480 pixels • Movie bitrate: 3 Mbps
60 fps	1/2-speed slow motion movies with a 16:9 aspect ratio are recorded. <ul style="list-style-type: none"> • Max. movie length*: 30 seconds (playback time: 1 minute) • Image size: 1280 × 720 pixels • Movie bitrate: 9 Mbps
15 fps	2× speed fast motion movies with a 16:9 aspect ratio are recorded. <ul style="list-style-type: none"> • Max. movie length*: 2 minutes (playback time: 1 minute) • Image size: 1920 × 1080 pixels • Movie bitrate: 12 Mbps

* The maximum movie length shown here refers only to the portion of the movie that is recorded in slow motion or fast motion.

The Open with HS Footage Checkbox

In the **HS movie** screen, select whether the camera records normal speed movies or HS movies (slow motion or fast motion movies) when movie recording starts.

Before applying the HS movie type setting, use the rotary multi selector to select **Open with HS footage** and press the **OK** button to turn the checkbox on or off.

- On (default setting): HS movies are recorded when recording begins.
- Off: Normal speed movies are recorded when recording begins. Press the **OK** button to switch to HS movie recording at the point where the camera should record for slow motion or fast motion playback.

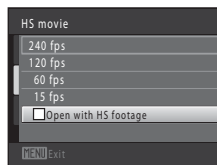

Movie Playback

In full-frame playback mode (📖 80), movies can be identified by the **Movie options** icon (📖 134). To play a movie, display it in full-frame playback mode and press the **OK** button.

Rotate the zoom control to **T** or **W** to adjust playback volume.

Rotate the rotary multi selector to advance or rewind the movie.

Playback controls are displayed at the top of the monitor. Press the rotary multi selector ◀ or ▶ to choose a control. The operations described below are available.

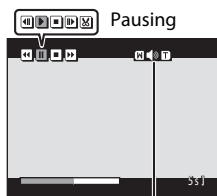
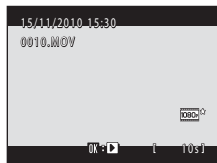

During playback
Volume indicator

Function	Icon	Description
Rewind	⏮	Hold down the OK button to rewind the movie.
Advance	⏭	Hold down the OK button to advance the movie.
Pause	⏸	Press the OK button to pause playback. The following operations can be performed while playback is paused using the controls displayed at the top in the monitor.
		Press the OK button to rewind the movie. Hold down the OK button for continuous rewinding.*
		Press the OK button to advance the movie. Hold down the OK button for continuous advancing.*
		Press the OK button to resume playback.
	⏸	Press the OK button to cut unwanted portions of a movie can be so that only the desired portions of a movie are saved (📖 141).
End	⏹	Press the OK button to return to full-frame playback mode.

* The movie can also be advanced or rewound by rotating the rotary multi selector.

✓ Playing Back Movies

The COOLPIX S8100 is not able to playback movies recorded with another make or model of digital camera.

Deleting Movies

Select a movie and press the **Delete** button in full-frame playback mode (📖 80) or thumbnail playback mode (📖 85). A confirmation dialog is displayed. See “Deleting Unwanted Images” (📖 29) for more information.

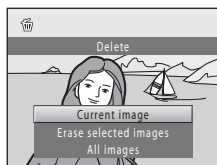

Editing Movies

The desired portions of a recorded movie can be saved as a separate file.

1 Play back the desired movie and pause playback (📖 140).

2 Press the rotary multi selector ◀ or ▶ to choose the ⏮ control, and then press the ⏹ button.

The movie edit screen is displayed.

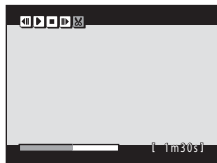

3 Press ▲ or ▼ to choose the ⏮ control (choose start point).

Rotate the rotary multi selector or press ◀ or ▶ to move the start point on the left edge to the beginning of the desired portion of the movie.

To cancel editing, press ▲ or ▼ to choose ↶ (return), and press the ⏹ button.



4 Press ▲ or ▼ to choose ⏮ (choose end point).

Rotate the rotary multi selector or press ◀ or ▶ to move the end point on the right edge to the end of the desired portion of the movie.

Select ▶ (preview) and press the ⏹ button to play back the specified portion of the movie that will be saved.

While the preview is playing, rotate the zoom control to **T/W** to adjust the volume. Rotate the rotary multi selector to advance or rewind the movie. While the preview is playing back, press the ⏹ button again to stop playback.

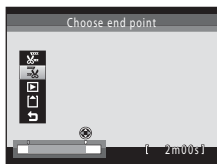

5 When the settings are finished, press ▲ or ▼ to choose ⏹ **Save** and press the ⏹ button.

6 Choose **Yes** and press the ⏹ button.

The edited movie is saved.

To exit without saving, select **No**.

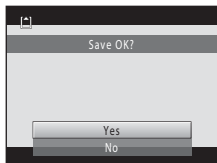

Notes on Movie Editing

- A movie that was created by editing cannot be trimmed again. To trim another area of the movie, select and edit the original movie.
- Movies are trimmed in one-second intervals, therefore the actual trimmed portion of the movie may differ slightly from the selected start and end points. Movies cannot be trimmed so that they are less than 2 seconds long.
- Editing functions are not available when there is not enough free space in the internal memory or on the memory card to save the edited copies.

More Information

See "Image/Sound File and Folder Names" ( 185) for more information.

Connecting to a TV

Connect the camera to a television to play images or movies back on the television. If your TV is equipped with an HDMI jack, a commercially available HDMI cable can be used to connect the camera to the TV for high-definition display.

- 1 Turn off the camera.

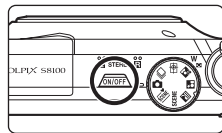

- 2 Connect the camera to the TV.

When using the supplied audio/video cable

Connect the yellow plug to the video-in jack and the white and red plugs to the audio-in jacks on the TV.

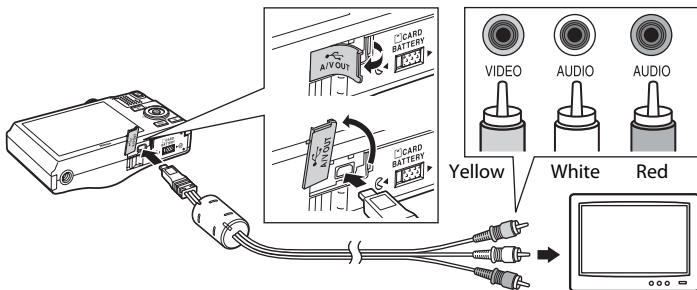

When using a commercially available HDMI cable

Connect the plug to the HDMI jack on the TV.

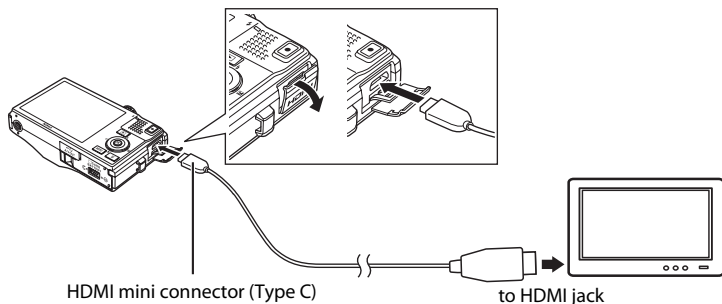

3 Tune the television to the video channel.

See the documentation provided with your television for details.



4 Hold down the button to turn on the camera.

The camera enters playback mode and images are displayed on the television.

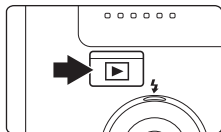
While connected to the TV, the camera monitor will remain off.



Notes on Connecting the HDMI Cable

- HDMI cable is not provided. Use a commercially available HDMI cable to connect the camera to a high-definition TV. The output terminal on this camera is an HDMI mini connector (type C). When purchasing an HDMI cable, be sure that the device end of the cable is an HDMI mini connector.
- **Image mode** ( 44) settings of  **2048 x 1536** or higher and **Movie** ( 134) settings of **HD 720p (1280 x 720)** or higher are recommended for images or movies that will be played back on a TV via HDMI connection.

Notes on Connecting the Cable

- When connecting the cable, be sure that the camera connector is properly oriented. Do not use force when connecting the cable to the camera. When disconnecting the cable, do not pull the connector at an angle.
- Do not connect the HDMI cable and audio/video cable to the camera simultaneously.
- Do not connect the HDMI cable and USB cable to the camera simultaneously.

If the Images Are Not Displayed on the Television

Be sure that the camera's video mode setting in the **Set up** menu ( 157) → **TV settings** ( 173) conforms to the standard used by your television.

Connecting to a Computer

Use the supplied USB cable to connect the camera to a computer and copy (transfer) images to the computer.

Before Connecting the Camera

Install the Software

Use the supplied ViewNX 2 CD and install the following software on the computer.

- ViewNX 2: Use the image transfer feature “Nikon Transfer 2” to save images that were captured with the camera on the computer. Saved images can be viewed and printed. Image and movie editing features are also supported.
- Panorama Maker 5: This software can join a series of images to create a single panorama image.

For more information on installing the software, refer to the *Quick Start Guide*.

Compatible Operating Systems

Windows

Windows 7 Home Basic/Home Premium/Professional/Enterprise/Ultimate, Windows Vista Home Basic/Home Premium/Business/Enterprise/Ultimate (Service Pack 2), or Windows XP Home Edition/Professional (Service Pack 3)

Macintosh

Mac OS X (version 10.4.11, 10.5.8, 10.6.4)

For information on the requirements for playing back high-definition movies, refer to “System Requirements” in the ViewNX 2 help information (📖 149).

Refer to the Nikon website for the latest information on operating system compatibility.

Note on Computer Connection

Disconnect other USB devices such as commercial USB chargers from the computer. Simultaneous connection of the camera and other USB devices to the computer could result in operation malfunction or excessive supply of power to the camera, causing damage to the camera or memory card. Refer to the documentation supplied with other USB devices for more information.

Connecting to a Computer

✓ Notes on Power Source

- When connecting the camera to a computer to transfer images, use a fully charged battery to prevent the camera from turning off unexpectedly.
- When the camera is connected to a computer via the supplied USB cable with **Auto** (default setting) selected for the **Charge by computer** option in the setup menu, the battery inserted into the camera is automatically charged using power supplied by the computer (150, 174).
- If the AC Adapter EH-62F (183) (available separately) is used, COOLPIX S8100 can be powered from an electrical outlet. Do not use any other make or model of AC adapter as they may cause the camera to overheat or malfunction.

Transferring Images from a Camera to a Computer

- 1 Start the computer to which ViewNX 2 was installed.
- 2 Be sure that the camera is off.
- 3 Connect the camera to the computer using the supplied USB cable.

Be sure that connectors are properly oriented. Do not attempt to insert connectors at an angle, and do not use force when connecting or disconnecting the USB cable.

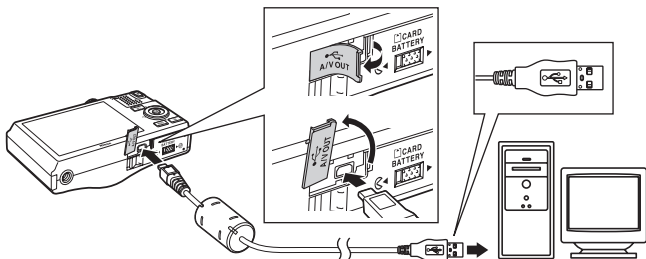

The camera is automatically turned on and the power-on lamp will light. The camera monitor will remain off.

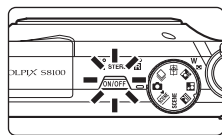

✓ Connecting the USB Cable

The connection may not be recognized if the camera is connected to the computer via a USB hub.

4 Start the ViewNX 2 image transfer feature “Nikon Transfer 2” installed on the computer.

• Windows 7

When the **Devices and Printers ▶ S8100** screen is displayed, click **Change program** under **Import pictures and videos**. Select **Import File using Nikon Transfer 2** in the **Change program** dialog and click **OK**.

Double-click **Import File** on the **Devices and Printers ▶ S8100** screen.

• Windows Vista

When the **AutoPlay** dialog is displayed, click **Import File using Nikon Transfer 2**.

• Windows XP

When the action selection dialog is displayed, select **Nikon Transfer 2 Import File**, and click **OK**.

• Mac OS X

Nikon Transfer 2 will start automatically when the camera is connected to the computer if **Yes** was selected in the **Auto-Launch setting** dialog when Nikon Transfer 2 was first installed.

- If charge for the battery inserted into the camera is low, the computer may not recognize the camera. If the camera is not recognized, images will not be transferred. When battery charging starts automatically using power supplied by the computer, wait until battery charge has reached a sufficient level to begin transfer.
- If there are a large number of images on the memory card, it may take some time for Nikon Transfer 2 to start.

5 Confirm that the source device is displayed in the transfer options **Source** panel and click **Start Transfer**.

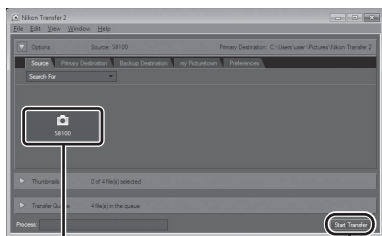

Source device

Start Transfer button

Any images that have not been transferred to the computer will be transferred (default setting of ViewNX 2).

Connecting to a Computer

ViewNX 2 starts automatically when the transfer is complete (default setting of ViewNX 2). Transferred images can be viewed.

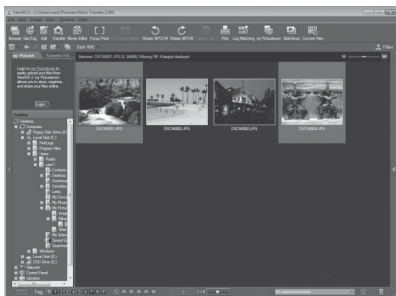

For more information on using ViewNX 2, refer to the ViewNX 2 help information (📖 149).

Disconnecting the Camera

Do not turn off the camera or disconnect the camera from the computer during transfer.

When transfer is complete, turn off the camera and disconnect the USB cable.



The camera turns off automatically if there is no communication with the computer for 30 minutes while the camera is connected via the USB cable.

🔋 Charging the Battery

The charge lamp slowly blinks green while the battery inserted into the camera is charging (📖 150).

Transferring Images Using a Computer's Card Slot or a Commercially-available Card Reader

When the memory card is inserted into a computer's card slot or into a commercially-available card reader, the images can be transferred using "Nikon Transfer 2", the image transfer feature of ViewNX 2.

- Make sure that the memory card being used is supported by the card reader or other card reading device.
- To transfer images, insert the memory card into the card reader or card slot and follow the procedure from step 4 ( 147).
- To transfer images saved in the camera's internal memory, the images must first be copied to a memory card using the camera ( 119).

Starting ViewNX 2 or Nikon Transfer 2 Manually

Windows

Choose **Start** menu > **All Programs** > **ViewNX 2** > **ViewNX 2**.

Double-clicking the **ViewNX 2** shortcut icon on the desktop will also start ViewNX 2.

Mac OS X

Open the **Applications** folder, open the **Nikon Software** > **ViewNX 2** folders in that order, and then double-click the **ViewNX 2** icon. Clicking the **ViewNX 2** icon on the Dock will also start ViewNX 2.

Click **Transfer** in the ViewNX 2 screen to start Nikon Transfer 2.

Viewing ViewNX 2 Help Information

For more information on ViewNX 2 or Nikon Transfer 2, start ViewNX 2 or Nikon Transfer 2 and select **ViewNX 2 Help** from the **Help** menu.

Panorama Creation with Panorama Maker 5

- Use a series of images captured in **Panorama assist** scene mode ( 68) to create a single panorama photo with Panorama Maker 5.
- Panorama Maker 5 can be installed on a computer using the supplied ViewNX 2 CD.
- After installation is complete, follow the procedure described below to start Panorama Maker 5.

Windows

Choose **Start** menu > **All Programs** > **ArcSoft Panorama Maker 5** > **Panorama Maker 5**.

Mac OS X

Open **Applications** and double-click the **Panorama Maker 5** icon.

- For more information on using Panorama Maker 5, refer to the on-screen instructions and help information contained in Panorama Maker 5.

Image File Names and Folder Names

See "Image/Sound File and Folder Names" ( 185) for more information.

Charging While Connecting to a Computer

When the **Charge by computer** option (📖 174) in the camera's setup menu is set to **Auto** (default setting), if the camera is connected to a computer using the USB cable, the battery inserted into the camera can be automatically charged depending on the ability of the computer to supply power.

See "Before Connecting the Camera" (📖 145) and "Transferring Images from a Camera to a Computer" (📖 146) for more information on connecting the camera to a computer.

Charge Lamp

The following chart explains charge lamp status when the camera is connected to a computer.

Charge lamp	Description
Blinks slowly (green)	Battery charging.
Off	Battery not charging. If the charge lamp changes from slow blinking (green) to off while the power-on lamp is lit, charging is complete.
Flickers (green)	<ul style="list-style-type: none"> The ambient temperature is not suited to charging. Charge the battery indoors with an ambient temperature of 5 °C to 35 °C (41 °F to 95 °F). A USB cable is not correctly connected or the battery is faulty. Reconnect the USB cable correctly or replace the battery. Computer is in sleep mode and does not supply power. Reboot a computer. The battery cannot be charged as computer's specifications or settings does not support power supply to the camera.

✓ Notes on Charging with Connection to a Computer

- The battery cannot be charged, nor can data be transferred, when the camera is connected to a computer before the camera's display language and date and time have been set (📖 18). If the camera's clock battery (📖 161) has been exhausted, the date and time must be reset before the battery can be charged or images can be transferred with connection to a computer. In this case, use the Charging AC Adapter EH-68P (📖 14) to charge the battery and then set the camera's date and time.
- If the camera is turned off, charging will also stop.
- If a computer enters sleep mode while charging, charging will stop and the camera may be turned off.
- When disconnecting the camera from a computer, turn the camera off and then disconnect the USB cable.
- About four hours and 30 minutes are required to charge a fully exhausted battery. Charging time increases when images are transferred while the battery is charging.
- When the camera is connected to a computer, an application installed on the computer, such as Nikon Transfer 2, may start. If the camera was connected to the computer for the sole purpose of charging the battery, exit the application.
- The camera turns off automatically if there is no communication with the computer for 30 minutes after the battery has finished charging.
- Depending upon computer specifications, settings, and power supply and allocation, it may be impossible to charge the battery inserted into the camera via computer connection.

Connecting to a Printer

Users of PictBridge-compatible (📖 201) printers can connect the camera directly to the printer and print images without using a computer.

Follow the procedures below to print images.

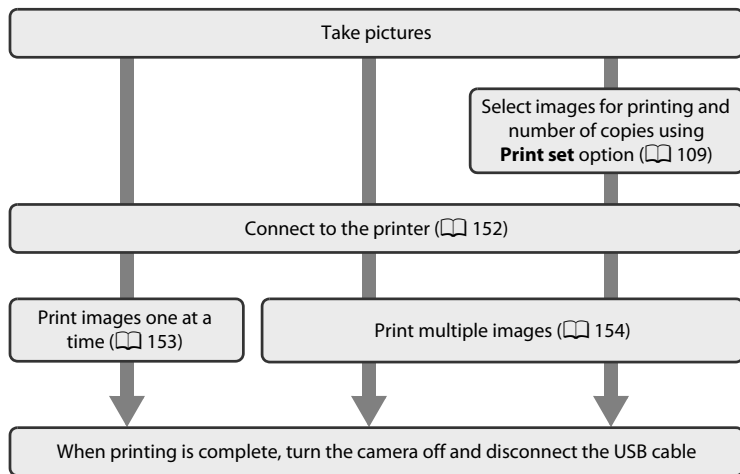

✔ Notes on Power Source

- When connecting the camera to a printer, use a fully charged battery to prevent the camera from turning off unexpectedly.
- If the AC Adapter EH-62F (available separately) is used, COOLPIX S8100 can be powered from an electrical outlet. Do not use any other make or model of AC adapters as they may cause the camera to heat up or malfunction.

🔍 Printing Images

In addition to printing images transferred to a computer from your personal printer and printing over a direct camera-to-printer connection, the following options are also available for printing images saved on the memory card:

- Inserting a memory card into a DPOF-compatible printer's card slot
- Taking a memory card to a digital photo lab

For printing using these methods, specify the images and the number of prints each to the memory card using the **Print set** option in the playback menu (📖 109).

Connecting the Camera to a Printer

- 1 Turn off the camera.

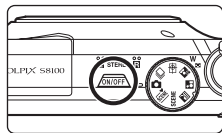

- 2 Turn on the printer.

Check printer settings.

- 3 Connect the camera to the printer using the supplied USB cable.

Be sure that connectors are properly oriented. Do not attempt to insert connectors at an angle, and do not use force when connecting or disconnecting the USB cable.

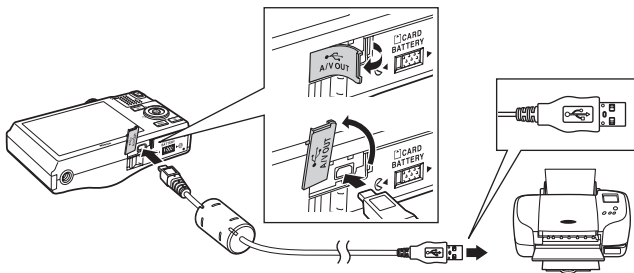

- 4 The camera is automatically turned on.

When properly connected, the **PictBridge** startup screen (①) will be displayed in the camera monitor, followed by the **Print selection** screen (②).

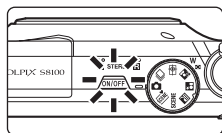

①

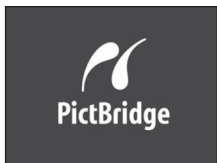

②

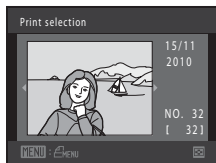

If the PictBridge Startup Screen Is Not Displayed

Turn the camera off and disconnect the USB cable. Set the **Charge by computer** option (📖 174) in the camera's setup menu to **Off** and reconnect the cable.

Printing Images One at a Time

After properly connecting the camera to the printer (📖 152), follow the procedures described below to print an image.

- 1 Use the rotary multi selector to choose the desired image and press the **OK** button.

Rotate the zoom control to **W** (📷) to display 12 thumbnails, and **T** (🔍) to switch back to full-frame playback.

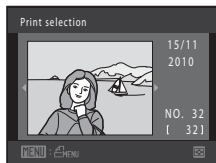

- 2 Choose **Copies** and press the **OK** button.

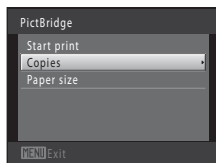

- 3 Choose the desired number of copies (up to nine) and press the **OK** button.

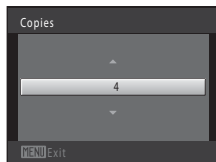

- 4 Choose **Paper size** and press the **OK** button.

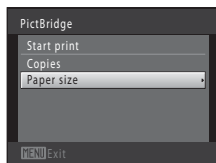

- 5 Choose the desired paper size and press the **OK** button.

To specify paper size using settings on the printer, choose **Default** in the paper size option.

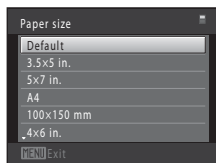

- 6** Choose **Start print** and press the **OK** button.

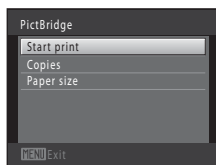

- 7** Printing begins.

Monitor display returns to the screen shown in step 1 when printing is complete.

To cancel printing before all copies have been printed, press the **OK** button.

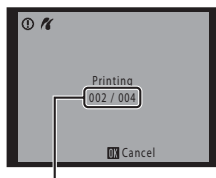

Current number of copies/
total number of copies

Printing Multiple Images

After properly connecting the camera to the printer (152), follow the procedures described below to print multiple images.

- 1** When the **Print selection** screen is displayed, press the **MENU** button.

The **Print menu** screen is displayed.

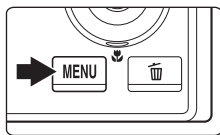

- 2** Use the rotary multi selector to choose **Paper size** and press the **OK** button.

To exit the print menu, press the **MENU** button.

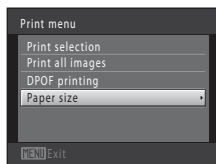

3 Choose the desired paper size and press the **OK** button.

To specify paper size using settings on the printer, choose **Default** in the paper size option.

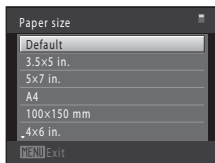

4 Choose **Print selection**, **Print all images**, or **DPOF printing** and press the **OK** button.

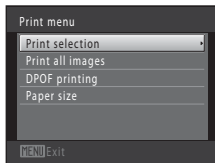

Print selection

Choose images (up to 99) and the number of copies (up to nine) of each.

- Rotate the rotary multi selector, or press ◀ or ▶ to select images, and press ▲ or ▼ to specify the number of copies to be printed.
- Images selected for printing can be identified by the check mark (☑) and the numeral indicating the number of copies to be printed. If no copies have been specified for images, the selection is canceled.
- Rotate the zoom control to **T** (Q) to switch back to full-frame playback or **W** (R) to display 12 thumbnails.
- Press the **OK** button when setting is complete.
- When the screen shown on the right is displayed, choose **Start print** and press the **OK** button to start printing. Choose **Cancel** and press the **OK** button to return to the print menu.

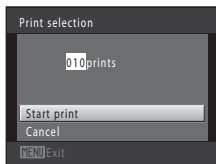

Print all images

One copy each of all images saved in the internal memory, or on the memory card, is printed.

- When the screen shown on the right is displayed, choose **Start print** and press the **OK** button to start print. Choose **Cancel** and press the **OK** button to return to the print menu.

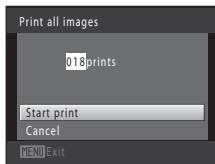

DPOF printing

Print images for which a print order was created using the **Print set** option (109).

- When the screen shown on the right is displayed, choose **Start print** and press the **OK** button to start printing. Choose **Cancel** and press the **OK** button to return to the print menu.
- To view the current print order, choose **View images** and press the **OK** button. To print images, press the **OK** button again.

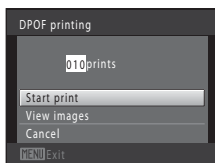

5 Printing begins.

Monitor display returns to the screen shown in step 2 when printing is complete.

To cancel printing before all copies have been printed, press the **OK** button.

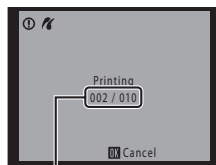















Current number of copies/
total number of copies

Paper Size

The camera supports the following paper sizes: **Default** (the default paper size for the printer connected to the camera), **3.5x5 in.**, **5x7 in.**, **100x150 mm**, **4x6 in.**, **8x10 in.**, **Letter**, **A3**, and **A4**. Only sizes supported by the printer will be displayed.

Setup Menu

The setup menu contains the following options.

Welcome screen	 159
Choose whether or not a welcome screen is displayed when the camera is turned on.	
Date	 160
Set camera clock and choose home and destination time zones.	
Monitor settings	 163
Adjust photo information display, image review, and monitor brightness settings.	
Date imprint	 165
Imprint shooting date and time on images.	
Vibration reduction	 166
Choose whether or not vibration reduction is enabled.	
Motion detection	 168
Enable or disable motion detection, which reduces the effects of subject movement and camera shake in still images.	
AF assist	 169
Enable or disable AF-assist illuminator.	
Digital zoom	 169
Enable or disable digital zoom.	
Sound settings	 170
Adjust sound settings.	
Auto off	 171
Set the amount of time that passes before the monitor turns off to save power.	
Format memory/Format card	 172
Format internal memory or memory card.	
Language	 173
Choose the language used for camera monitor display.	
TV settings	 173
Adjust settings necessary for connection to television.	
Charge by computer	 174
Choose whether or not to charge the camera battery when connecting to a computer via the USB cable.	
Blink warning	 175
Specify whether or not the camera detects human faces that have blinked with shooting using face detection.	

Reset all

177

Restore camera settings to default values.

Firmware version



179

Display camera firmware version.

Displaying the Setup Menu

1 Press the MENU button.

The menu is displayed.

If the **MENU** button was pressed in  (scene auto selector), , or , press the rotary multi selector () to display the tabs.

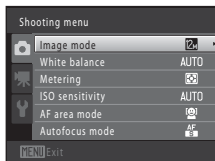
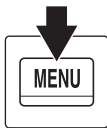

2 Press the rotary multi selector ◀.

Tab selection is activated.

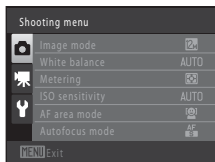

3 Press ▲ or ▼ to choose the Y tab.

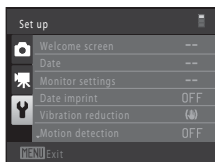

4 Press ► or the OK button.

The setup menu items can be selected.

Use the rotary multi selector to choose and apply settings () 9).

To exit the setup menu, press the **MENU** button or ◀ to select a different tab.

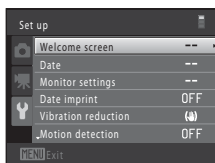

Welcome Screen

MENU button →  (Setup menu) (📖 158) → Welcome screen

Choose whether or not a welcome screen is displayed when the camera is turned on.

None (default setting)

The camera enters shooting or playback mode without displaying the welcome screen.

COOLPIX

The camera displays a welcome screen and enters shooting or playback mode.

Select an image

Displays an image selected for the welcome screen. When the image selection screen is displayed, select an image (📖 115) and press the  button.

- As the selected image is saved by the camera, it will be displayed when the camera is turned on even if the original image is deleted.
- Images captured at an **Image mode** (📖 44) setting of  **3968 × 2232**, copies created at a size of 320 × 240 or smaller using the small picture (📖 127) or crop (📖 128) function, and still images saved while recording high-definition or Full HD movies (📖 131) cannot be selected.







Date

MENU button →  (Setup menu) (📖 158) → Date

Set the camera clock.

Date



Set camera clock to current date and time.
Use the rotary multi selector to set the date and time in the date screen.

- Select an item: press  or  (changes between **D**, **M**, **Y**, hour, minute, **DMY** (the order in which the day, month, and year are displayed)).
- Edit the highlighted item: rotate the rotary multi selector or press  or .
- Apply the setting: finally, select **DMY** and press the  button or  (📖 19).

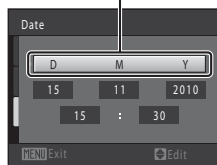
DMY (the order in which the day, month, and year are displayed)



Time zone

 **Home time zone** can be specified and daylight saving is enabled or disabled. When the travel destination () is selected, local time (📖 162) is automatically calculated and images are saved with the shooting date and time of the selected region. This can be useful when travelling.

Selecting Travel Destination Time Zone

- 1 Use the rotary multi selector to choose **Time zone** and press the  button.

The **Time zone** screen is displayed.

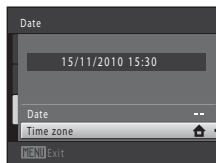

- 2 Choose  **Travel destination** and press the  button.

The date and time displayed in the monitor changes according to the region currently selected.

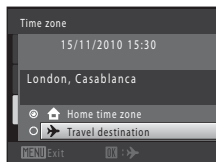

3 Press ►.

The travel destination screen is displayed.

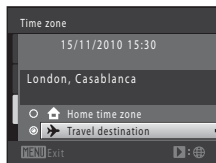
**4** Press ◀ or ▶ to choose the travel destination time zone.

If daylight saving time is in effect, press ▲ to enable daylight saving time function. ☀ is displayed at the top of the monitor and the camera clock is advanced one hour. Press ▼ to disable the daylight saving time function.

Press the **OK** button to apply the travel destination time zone.

While the travel destination time zone is selected, the 📍 icon will be displayed in the monitor when the camera is in shooting mode.

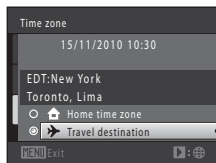
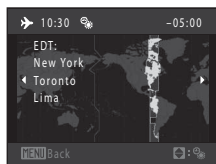
**✔ Clock Battery**

The camera clock is powered by the clock battery. The clock battery charges when the main battery is inserted or an AC adapter is connected, and can provide several days of backup power after about ten hours of charging.

📌 Home Time Zone

- To switch to the home time zone, choose **Home time zone** in step 2 and press the **OK** button.
- To change the home time zone, choose **Home time zone** in step 2, and complete steps 3 and 4.

📌 Daylight Saving Time

When daylight saving time starts or ends, turn the daylight saving time function on or off from the time zone selection screen displayed in step 4.

📌 Imprinting Date on Images

Enable date imprint from the **Date imprint** option (📖 165) in the setup menu after the date and time have been set. When the **Date imprint** option is enabled, images will be saved with shooting date imprinted on them.



 **Time Zones**

The camera supports the time zones listed below.

For time zones not listed below, set the camera clock to local time from the **Date** option.

UTC +/-	Location	UTC +/-	Location
-11	Midway, Samoa	+1	Madrid, Paris, Berlin
-10	Hawaii, Tahiti	+2	Athens, Helsinki, Ankara
-9	Alaska, Anchorage	+3	Moscow, Nairobi, Riyadh, Kuwait, Manama
-8	PST (PDT): Los Angeles, Seattle, Vancouver	+4	Abu Dhabi, Dubai
-7	MST (MDT): Denver, Phoenix	+5	Islamabad, Karachi
-6	CST (CDT): Chicago, Houston, Mexico City	+5.5	New Delhi
-5	EST (EDT): New York, Toronto, Lima	+6	Colombo, Dhaka
-4.5	Caracas	+7	Bangkok, Jakarta
-4	Manaus	+8	Beijing, Hong Kong, Singapore
-3	Buenos Aires, Sao Paulo	+9	Tokyo, Seoul
-2	Fernando de Noronha	+10	Sydney, Guam
-1	Azores	+11	New Caledonia
±0	London, Casablanca	+12	Auckland, Fiji

Monitor Settings

MENU button →  (Setup menu) ( 158) → Monitor settings

Set the options below.

Photo info

Choose information displayed in the monitor during shooting and playback mode. → ( 164)

Image review

On (default setting): The captured image is displayed immediately after shooting, and then the camera returns to the shooting screen.

Off: The captured image is not displayed after shooting.



Brightness

Choose from five settings for monitor brightness. The default setting is **3**.

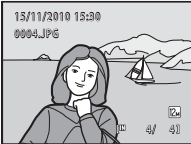

Photo Info

Select whether or not the photo information is displayed in the monitor.

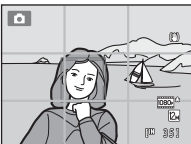
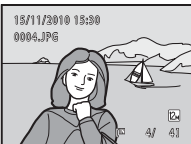
See “The Monitor” (📖 6) for information on indicators displayed in the monitor.

	Shooting mode	Playback mode
Show info		
Auto info (default setting)	The same information as in Show info is displayed. If no operations are performed after a few seconds, the display will be the same as Hide info . The information is displayed again when an operation is performed.	
Hide info		
Framing grid	 <p>In addition to information shown with Auto info above, a framing grid is displayed to help frame pictures in 📷 (auto) mode. In other shooting modes, the same information as in Auto info is displayed.</p>	 <p>The same information as in Auto info is displayed.</p>

Date Imprint (Imprinting Date and Time)

MENU button →  (Setup menu) ( 158) → Date imprint

The shooting date and time can be imprinted on the images with shooting, allowing the information to be printed even from printers that do not support date printing ( 112).



 **Date**

Date is imprinted on images.

 **Date and time**



Date and time are imprinted on images.

OFF **Off (default setting)**

Date and time are not imprinted on images.

The icon for the current setting is displayed in the monitor during shooting ( 6). However, when **Off** is selected, no icon is displayed.

Notes on Date Imprint

- Imprinted dates form a permanent part of image data and cannot be deleted. The date and time cannot be imprinted on images after they have been captured.
- The date cannot be imprinted in the following situations:
 - When using the  (backlighting) (when **HDR** is set to **On**), **Museum**, or **Panorama assist** scene mode
 - When using continuous shooting mode (except multi-shot 16)
 - When shooting movies
 - When the image is a still image saved during movie recording
- Dates imprinted at an **Image mode** setting ( 44) of **VGA 640 × 480** may be difficult to read. Choose an **Image mode** setting of **PC 1024 × 768** or higher when using date imprint.
- The date is saved using the format selected in the setup menu's **Date** item ( 18, 160).

Date Imprint and Print Set

When printing from DPOF-compatible printers that support the printing of shooting date and photo information, the date and information can be printed without imprinting this information on them using settings in the **Print set** option ( 109).

Vibration Reduction

MENU button →  (Setup menu) (📖 158) → Vibration reduction

Choose a vibration reduction option for shooting.

Vibration reduction effectively reduces blur, caused by slight hand movement known as camera shake, which commonly occurs when shooting with zoom applied or at slow shutter speeds. The effects of camera shake are reduced when recording movies, in addition to when taking still pictures.

Set **Vibration reduction** to **Off** when using a tripod to stabilize the camera during shooting.

On (hybrid)

The effects of camera shake are corrected optically using a lens shift method, and electronic vibration reduction is used to process still images that are captured in the following situations.

- When the flash does not fire
- When the shutter speed is slower than 1/60 seconds.
- When **Self-timer** is set to Off
- When ISO sensitivity is 200 or lower

On (default setting)

The effects of camera shake are corrected using a lens shift method.

Camera automatically detects the panning direction and only corrects for vibration due to camera shake. When the camera is panned, for example, vibration reduction reduces only vertical shake. If the camera is tilted, vibration reduction affects only horizontal shake.

OFF Off

Vibration reduction is not enabled.

The current vibration reduction setting can be confirmed in the camera monitor with shooting (📖 6, 23). When **Off** is selected, no icon is displayed.

Notes on Vibration Reduction

- Vibration reduction may take a few seconds to activate after the power is turned on, or the camera enters shooting mode from playback mode. Wait until the image of the monitor stabilizes before shooting.
- Due to characteristics of the vibration reduction function, images displayed in the camera's monitor immediately after shooting may be displayed blurry.
- Vibration reduction may be unable to completely eliminate the effects of camera shake in some situations.
- Vibration reduction cannot be used for movies that are recorded when **Movie options** in the movie menu is set to **HS movie**.
- When **On (hybrid)** is selected, electronic vibration reduction may not be able to correct the image if vibrations are very small or very large.
- When **On (hybrid)** is selected, electronic vibration reduction is disabled if shutter speed is fast or very slow.
- When electronic vibration reduction is operating while **On (hybrid)** is selected, the shutter is released twice for each shot and then the image is corrected, therefore more time is needed to save images. The **Shutter sound** (📖 170) is heard only once. One image is saved.

Motion Detection

MENU button →  (Setup menu) (📖 158) → Motion detection





Enable motion detection to reduce the effects of subject movement and camera shake when shooting still images.



Auto

When the camera detects subject movement or camera shake, the ISO sensitivity and shutter speed are automatically increased to reduce blurring.

However, motion detection does not function in the following situations.

- When the flash mode is set to fill-flash
- In  (auto) mode, when **ISO sensitivity** (📖 49) is set to any setting other than **Auto**
- In the following scene modes:
 -  (night landscape) (📖 58)
 -  (night portrait) (📖 59)
 -  (backlighting) (📖 60)
 - **Dusk/dawn** (📖 63), **Museum** (📖 66), **Fireworks show** (📖 66)
- In subject tracking mode (📖 70)
- In continuous shooting mode (📖 73)

OFF Off (default setting)

Motion detection is not enabled.

The current motion detection setting can be confirmed in the camera monitor with shooting (📖 6, 23). The motion detection icon turns green when the camera detects camera shake and increases shutter speed. When **Off** is selected, no icon is displayed.

Notes on Motion Detection

- Motion detection may be unable to completely eliminate the effects of subject movement and camera shake in some situations.
- Motion detection may not function if the subject exhibits significant movement or is too dark.
- The images captured using motion detection may be somewhat “grainy” in appearance.

AF Assist

MENU button →  (Setup menu) (📖 158) → AF assist

Enable or disable AF-assist illuminator, which assists autofocus operation when the subject is dimly lit.

Auto (default setting)

AF-assist illuminator will be used to assist the focus operation when the subject is dimly lit. The illuminator has a range of about 8.0 m (26 ft.) at the maximum wide-angle position and about 4.0 m (13 ft.) at the maximum telephoto position.

Note that for some scene modes or focus areas even when **Auto** is selected, AF-assist illuminator may not light.

Off

AF-assist illuminator does not light. The camera may be unable to focus under dim lighting.

Digital Zoom

MENU button →  (Setup menu) (📖 158) → Digital zoom

Enable or disable digital zoom.





On (default setting)

When the camera is zoomed in to the maximum optical zoom position, rotating the zoom control to **T** (📷) triggers digital zoom (📖 25).



Off

Digital zoom will not be activated (except when recording movies).

✔ Notes on Digital Zoom

- When digital zoom is in effect, the camera focuses at the center of the frame.
- Digital zoom cannot be used in the following situations.
 - When using the scene auto selector,  (night landscape),  (night portrait),  (backlighting) (when **HDR** is set to **On**), and **Portrait** scene modes
 - When using subject tracking mode
 - When continuous shooting mode is set to **Multi-shot 16**
 - When using  (smile timer)
- While digital zoom is in effect, metering is set to center-weighted or spot metering.

Sound Settings

MENU button →  (Setup menu) ( 158) → Sound settings

Adjust the following sound settings.

Button sound

Select **On** (default setting) or **Off**. When **On** is selected, a beep will sound once when operations are completed successfully, twice when the camera acquires focus on the subject, and three times when an error is detected. Start-up sound will also play when the camera is turned on.

Shutter sound

Select **On** (default setting) or **Off**.

Shutter sound cannot be heard in the following situation, even if **On** is selected.

- When **Museum** is selected in scene mode
- When continuous shooting mode is selected
- When a still image is being saved while recording a movie



Auto Off

MENU button →  (Setup menu) ( 158) → Auto off

If no operations are performed for a specified amount of time, the monitor turns off and the camera enters standby mode ( 17).

Choose the time allowed to elapse before the camera enters standby mode from **30 s**, **1 min** (default setting), **5 min**, and **30 min**.

When the Monitor Has Turned Off to Save Power



- When the camera is in standby mode, the power-on lamp blinks.
- If no operations are performed for another three minutes, the camera will turn off automatically.
- When the power-on lamp is blinking, the following operations will turn the monitor back on.
 - Pressing the power switch, shutter-release button,  button, or  (movie-record) button.
 - Rotating the mode dial.

Auto Off

The time allowed to elapse before the camera enters standby mode is fixed in the following situations:

- While menus are displayed: 3 minutes
- During slide show playback: up to 30 minutes
- When the AC adapter EH-62F is connected: 30 minutes

Format Memory/Format Card

MENU button →  (Setup menu) ( 158) → Format memory/Format card

Use this option to format the internal memory or a memory card.

Formatting the Internal Memory

To format the internal memory, remove the memory card from the camera.

The **Format memory** option is displayed in the setup menu.

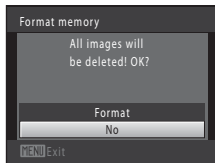

Formatting a Memory Card

When a memory card is inserted in the camera, the **Format card** option is displayed in the setup menu.

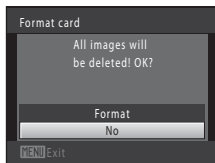

Notes on Formatting Internal Memory and Memory Cards

- **Formatting the internal memory or memory cards permanently deletes all data.** Be sure to transfer important images to a computer before formatting.
- Album icon settings ( 97) are reset to their default settings (number icons) when the internal memory or memory card is formatted.
- Do not turn the camera off or open the battery-chamber/memory card slot cover during formatting.
- Be sure to use this camera to format memory cards previously used in other devices the first time they are inserted into the COOLPIX S8100.

Language

MENU button →  (Setup menu) (📖 158) → Language

Choose one of 24 languages for display of camera menus and messages.

Čeština	Czech	Polski	Polish
Dansk	Danish	Português	Portuguese
Deutsch	German	Русский	Russian
English	(default setting)	Suomi	Finnish
Español	Spanish	Svenska	Swedish
Ελληνικά	Greek	Türkçe	Turkish
Français	French	简体中文	Simplified Chinese
Indonesia	Indonesian	繁體中文	Traditional Chinese
Italiano	Italian	日本語	Japanese
Magyar	Hungarian	한글	Korean
Nederlands	Dutch	ภาษาไทย	Thai
Norsk	Norwegian	عربي	Arabic

TV Settings

MENU button →  (Setup menu) (📖 158) → TV settings

Adjust settings for connection to a television.

Video mode

Choose from **NTSC** and **PAL**.

HDMI

Choose an image resolution for HDMI output from **Auto** (default setting), **480p**, **720p**, or **1080i**. When **Auto** is selected, the option best suited to the high-definition TV to which the camera is connected is automatically selected from **480p**, **720p**, or **1080i**.

HDMI device control

Select whether or not the camera can receive signals from a TV that supports the HDMI-CEC standard when is connected to the TV via HDMI.

When **On** (default setting) is selected, the TV's remote control can be used in place of the rotary multi selector and zoom control to control the camera during playback. Image selection, movie playback and pause, and switching between full-frame playback mode and 4-image thumbnail display mode are available.



- Refer to the TV's operating instructions for information about the TV's HDMI-CEC compatibility.



HDMI and HDMI-CEC

HDMI (High-Definition Multimedia Interface) is a multimedia interface. HDMI-CEC (HDMI-Consumer Electronics Control) allows compatible devices to inter-operate.

Charge by Computer

MENU button →  (Setup menu) ( 158) → Charge by computer

Choose whether or not the battery inserted into the camera is charged when the camera is connected to a computer via the USB cable ( 150).

Auto (default setting)

When the camera is connected to a computer that is running, the battery inserted into the camera is automatically charged using power supplied by the computer.

Off

The battery inserted into the camera is not charged when the camera is connected to a computer.



Notes on Connecting the Camera to a Printer

- The battery cannot be charged with connection to a printer, even if the printer complies with the PictBridge standard.
- When **Auto** is selected for **Charge by computer**, it may be impossible to print images with direct connection of the camera to some printers. If the PictBridge startup screen is not displayed in the monitor after the camera is connected to a printer and turned on, turn the camera off and disconnect the USB cable. Set **Charge by computer** to **Off** and reconnect the camera to the printer.

Blink Warning

MENU button →  (Setup menu) (📖 158) → Blink warning

Specify whether or not the camera detects human subjects that have blinked using face detection (📖 52) when shooting in the following modes.

-  (auto) mode (when **Face priority** (📖 50) is selected for AF area mode option).
- In the following scene modes:
 - Scene auto selector (📖 56)
 -  (night portrait) (📖 59)
 - **Portrait** (📖 61)

On

When the camera detects that one or more human subjects may have blinked in an image captured using face detection, the **Did someone blink?** screen is displayed in the monitor.

The face of the human subject that may have closed his/her eyes is framed by a yellow border. Should this occur, check the image and determine whether or not another image should be captured.

See "Operating the Blink Warning Screen" (📖 176) for more information.

Off (default setting)

Blink warning is not enabled.

Note on Blink Warning

Blink warning does not function when using continuous shooting mode or smile timer (📖 34).

Operating the Blink Warning Screen

When the **Did someone blink?** screen shown on the right is displayed in the monitor, the operations described below are available.

If no operations are performed within a few seconds, the camera automatically returns to shooting mode.



Function	Control	Description
Enlarge the detected face that blinked	T (Q)	Rotate the zoom control to T (Q).
Switch to full-frame playback mode	W (checkered flag)	Rotate the zoom control to W (checkered flag).
Select the face to be displayed		If the camera detects that more than one human subject blinked, press ◀ or ▶ to switch the display to another face.
Delete the image		Press the button.
Switch to shooting mode		Press the button or shutter-release button.

Reset All

MENU button →  (Setup menu) (📖 158) → Reset all

When **Reset** is selected, the camera's settings will be restored to their default values.

Basic Shooting Functions

Option	Default value
Flash mode (📖 30)	Auto
Self-timer (📖 33)	Off
Macro mode (📖 36)	Off
Creative slider adjustment (📖 38)	Off
Exposure compensation (📖 40, 41)	0.0

Shooting Menu

Option	Default value
Image mode (📖 44)	 4000 × 3000
White balance (📖 46)	Auto
Metering (📖 48)	Matrix
ISO sensitivity (📖 49)	Auto
AF area mode (📖 50)	Face priority
Autofocus mode (📖 54)	Single AF

Scene Mode

Option	Default value
Scene menu (📖 55)	Portrait
Hue adjustment in Food mode (📖 65)	Center

Backlighting Menu

Option	Default value
HDR (📖 60)	Off

Subject Tracking Menu

Option	Default value
Autofocus mode (📖 72)	Full-time AF

Continuous Shooting Menu

Option	Default value
Continuous (📖 75)	Continuous H

Movie Menu

Option	Default value
Movie options (📖 134)	Movie HD 1080p★ (1920 × 1080)
Open with HS footage (📖 139)	On
Autofocus mode (📖 135)	Single AF
Wind noise reduction (📖 136)	Off

Setup Menu

Option	Default value
Welcome screen (📖 159)	None
Photo info (📖 163)	Auto info
Image review (📖 163)	On
Brightness (📖 163)	3
Date imprint (📖 165)	Off
Vibration reduction (📖 166)	On
Motion detection (📖 168)	Off
AF assist (📖 169)	Auto
Digital zoom (📖 169)	On
Button sound (📖 170)	On
Shutter sound (📖 170)	On
Auto off (📖 171)	1 min
HDMI (📖 173)	Auto
HDMI device control (📖 173)	On
Charge by computer (📖 174)	Auto
Blink warning (📖 175)	Off

Others

Option	Default value
Paper size (📖 153, 154)	Default
Frame interval for Slide show (📖 113)	3 s

- Selecting **Reset all** also clears the current file number (📖 185) from memory. Numbering will continue from the lowest number available. To reset file numbering to "0001", delete all images saved in the internal memory or on the memory card (📖 29) before selecting **Reset all**.
- The following menu settings will remain unaffected when menus are reset with **Reset all**.

Shooting menu:

Preset manual data (📖 47) acquired for **White balance**

Playback menu:

Sequence display options (📖 121), **Choose key picture** (📖 121)

Setup menu:

Date (📖 160), **Language** (📖 173), **Video mode** under **TV settings** (📖 173)

Firmware Version

MENU button → 🗑️ (Setup menu) (📖 158) → Firmware version

View the current camera firmware version.



Maximizing Camera Life and Performance

To ensure continued enjoyment of this Nikon product, observe the following precautions when using or storing the device.

Keep dry

The device will be damaged if immersed in water or subjected to high humidity.

Do not drop

The product may malfunction if subjected to strong shock or vibration.

Handle the lens and all moving parts with care

Do not apply force to the lens, lens cover, monitor, memory card slot, or battery chamber. These parts are easily damaged. Applying force to the lens cover could result in camera malfunction or damage to the lens. Should the monitor break, care should be taken to avoid injury caused by broken glass and to prevent the liquid crystal from the display touching the skin or entering the eyes or mouth.

Do not point the lens at strong light sources for extended periods

Avoid pointing the lens at the sun or other strong light sources for extended periods when using or storing the camera. Intense light may cause deterioration of the CCD image sensor, producing a white blur effect in photographs.

Keep away from strong magnetic fields

Do not use or store this device in the vicinity of equipment that generates strong electromagnetic radiation or magnetic fields. Strong static charge or the magnetic fields produced by equipment such as radio transmitters could interfere with the monitor, damage data saved on the memory card, or affect the product's internal circuitry.

Avoid sudden changes in temperature

Sudden changes in temperature, such as when entering or leaving a heated building on a cold day, can cause condensation to form inside the device. To prevent condensation, place the device in a carrying case or a plastic bag before exposing it to sudden changes in temperature.

Turn the product off before removing or disconnecting the power source

Do not remove the battery while the product is on, or while images are being saved or deleted. Forcibly cutting power in these circumstances could result in loss of data or in damage to product memory or internal circuitry.

 **The Battery**

- Check the battery level before using the camera and replace or charge the battery if necessary. Do not continue charging once the battery is fully charged as this will result in reduced battery performance. Whenever possible, carry a fully charged spare battery when taking pictures on important occasions.
- Do not use the battery at ambient temperatures below 0 °C (32 °F) or above 40 °C (104 °F).
- Charge the battery indoors with an ambient temperature of 5 °C to 35 °C (41 °F to 95 °F) before use.
- When charging the COOLPIX S8100 using the Charging AC adapter EH-68P or a computer, the charge capacity may decrease at ambient temperatures 45 °C to 60 °C (113 °F to 140 °F).
- The battery is not charged at ambient temperatures below 0 °C (32 °F) or above 60 °C (140 °F).
- Note that the battery may become hot during use; wait for the battery to cool before charging. Failure to observe these precautions could damage the battery, impair its performance, or prevent it from charging normally.
- On cold days, the capacity of batteries tends to decrease. Be sure that the battery is fully charged before heading outside to take pictures in cold weather. Keep spare batteries in a warm place and exchange as necessary. Once warmed, a cold battery may recover some of its charge.
- Dirt on the battery terminals can prevent the camera from functioning. Should the battery terminals become dirty, wipe them off with a clean, dry cloth before use.
- If the battery will not be used for some time, insert it in the camera and run it flat before removing it for storage. The battery should be stored in a cool location with an ambient temperature of 15 to 25 °C (59 to 77 °F). Do not store the battery in hot or extremely cold locations.
- Always remove the battery from the camera or optional battery charger when it is not being used. When inserted, minute amounts of current are drawn from the battery even when not in use. This may result in excessive draining of the battery and complete loss of function. Turning the camera on or off while the battery is exhausted can result in reduced battery life.
- Recharge the battery at least once every six months and completely exhaust it before returning it to storage.
- After removing the battery from the camera or optional battery charger, replace the supplied terminal cover and store in a cool place.
- A marked drop in the time a fully-charged battery retains its charge, when used at room temperature, indicates that the battery needs to be replaced. Purchase a new EN-EL12 battery.
- Replace the battery when it no longer holds a charge. Used batteries are a valuable resource. Please recycle used batteries in accordance with local regulations.

Cleaning

Lens	Avoid touching glass parts with your fingers. Remove dust or lint with a blower (typically a small device with a rubber bulb attached to one end that is pumped to produce a stream of air out the other end). To remove fingerprints or other stains that cannot be removed with a blower, wipe the lens with a soft cloth, using a spiral motion that starts at the center of them and working toward the edges. If this fails, clean the lens using a cloth lightly dampened with commercial lens cleaner.
Monitor	Remove dust or lint with a blower. To remove fingerprints and other stains, clean the monitor with a soft, dry cloth, being careful not to apply pressure.
Body	Use a blower to remove dust, dirt, or sand, then wipe gently with a soft, dry cloth. After using the camera at the beach or other sandy or dusty environment, wipe off any sand, dust, or salt with a dry cloth lightly dampened with fresh water and dry thoroughly. Note that foreign matter inside the camera could cause damage not covered by the warranty.

Do not use alcohol, thinner, or other volatile chemicals.

Storage

Turn the camera off when not in use. Be sure that the power-on lamp is off before putting the camera away. Remove the battery if the camera will not be used for an extended period. Do not store the camera with naphtha or camphor moth balls, or in any of the following locations:

- Next to equipment that produces strong electromagnetic fields, such as televisions or radios
- Exposed to temperatures below -10°C (14°F) or above 50°C (122°F)
- Places that are poorly ventilated or subject to humidity of over 60%

To prevent mold or mildew, take the camera out of storage at least once a month. Turn the camera on and release the shutter a few times before putting the camera away again.

Notes on the Monitor

- The monitor may contain a few pixels that are always lit or that do not light. This is a characteristic common to all TFT LCD displays, and does not indicate a malfunction. Images saved using the product will not be affected.
- Images in the monitor may be difficult to see under bright lighting.
- The monitor is lit by an LED backlight. Should the monitor begin to dim or flicker, contact your Nikon-authorized service representative.

Optional Accessories

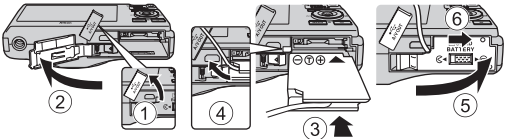
Rechargeable battery	Rechargeable Li-ion Battery EN-EL12
Charging AC adapter	Charging AC Adapter EH-68P*, EH-68P (AR)*
Battery charger	Battery Charger MH-65
AC adapter	<p>AC Adapter EH-62F</p> <p>Connecting the EH-62F</p>  <p>Be sure that the AC adapter cord has been properly aligned in AC adapter and battery chamber grooves before closing the battery-chamber/memory card slot cover. If the cord is not properly aligned in the grooves, the cover and cord may be damaged when the cover is closed.</p>
USB cable	USB Cable UC-E6
Audio/video cable	Audio Video Cable EG-CP16

* When using in other countries, use a plug adapter (commercially available) as necessary. For more information about plug adapters, consult your travel agency.

Approved Memory Cards

The following Secure Digital (SD) memory cards have been tested and approved for use in this camera.

Memory cards with an SD Speed Class rating of 6 or faster are recommended for recording movies. Movie recording may stop unexpectedly when memory cards with a lower Speed Class rating are used.

	SD memory card	SDHC memory card ²	SDXC memory card ³
SanDisk	2 GB ¹	4 GB, 8 GB, 16 GB, 32 GB	64 GB
TOSHIBA	2 GB ¹	4 GB, 8 GB, 16 GB, 32 GB	64 GB
Panasonic	2 GB ¹	4 GB, 8 GB, 12 GB, 16 GB, 24 GB, 32 GB	48 GB, 64 GB
Lexar	2 GB ¹	4 GB, 8 GB, 16 GB, 32 GB	–

¹ If the memory card will be used with a card reader or similar device, check that device supports 2 GB cards.

² SDHC compliant.

If the memory card will be used with a card reader or similar device, check that device supports SDHC.



³ SDXC compliant.

If the memory card will be used with a card reader or similar device, check that device supports SDXC.



- Contact the manufacturer for details on the above cards.

Image/Sound File and Folder Names



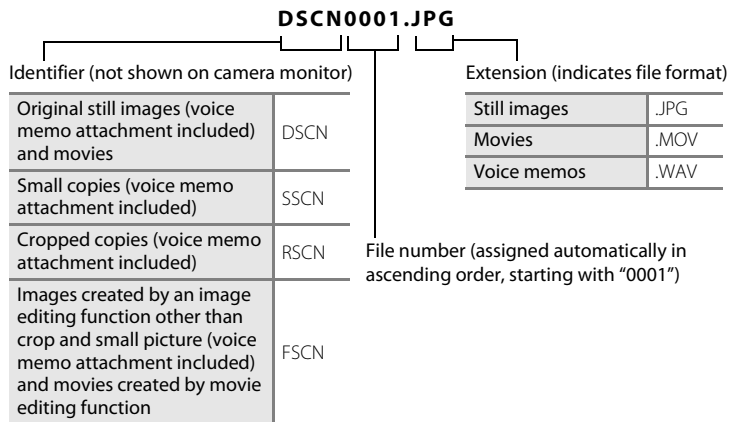







Images, movies, or voice memos are assigned file names as follows.











- Files are saved in folders named with a folder number followed by an identifier: "P_" plus a three-digit sequential number for images captured in **Panorama assist** scene mode (e.g. "101P_001"; 📖 68) and "NIKON" for all other images (e.g. "100NIKON"). When the number of files within a folder reaches 9999, a new folder will be created. File numbers will be assigned automatically starting with "0001."
- Voice memo file names have the same identifier and file number as the image to which the voice memo is attached.
- Files copied using **Copy>Selected images** are copied to the current folder, where they are assigned new file numbers in ascending order starting from the largest file number in memory. **Copy>All images** copies all folders from the source medium; file names do not change but new folder numbers are assigned in ascending order, starting from the largest folder number on the destination medium (📖 119).
- A single folder can hold up to 200 files; if the current folder already contains 200 files, a new folder, named by adding one to the current folder name, will be created the next time an image is captured. If the current folder is numbered 999 and contains 200 files, or an image is numbered 9999, no further images can be captured until the internal memory or memory card is formatted (📖 172), or a new memory card is inserted.

Error Messages

The following table lists the error messages and other warnings displayed in the monitor, as well as the solutions for dealing with them.

Display	Problem	Solution	
 (blinks)	Clock not set.	Set date and time.	160
	Battery running low.	Prepare to charge or replace battery.	12, 14
 Battery exhausted.	Battery exhausted.	Charge or replace battery.	12, 14
 Battery temperature high	Battery temperature is high.	Turn off camera, and allow battery to cool down before resuming use. After five seconds, this message will disappear, the monitor will turn off, and the power-on lamp will blink rapidly. After the lamp blinks for three minutes, the camera will turn off automatically. Pressing the power switch also turns off the camera.	17
 The camera will turn off to prevent overheating.	Inside of the camera has become hot. The camera turns off automatically.	Leave the camera off until the inside of the camera has cooled and then turn it on again.	–
 ● (● blinks red)	Camera cannot focus.	<ul style="list-style-type: none"> • Refocus. • Use focus lock. 	26, 27 51
 Please wait for the camera to finish recording.	Camera cannot perform other operations until saving is complete.	Wait until message clears from display automatically when saving is complete.	–
 Memory card is write protected.	Write-protect switch is in “lock” position.	Slide write-protect switch to “write” position.	21
 This card cannot be used.	Error accessing memory card.	<ul style="list-style-type: none"> • Use approved card. • Check that terminals are clean. • Confirm that memory card is correctly inserted. 	184 20
 This card cannot be read.			20



Display	Problem	Solution	
 Card is not formatted. Format card? Yes No	Memory card has not been formatted for use in COOLPIX S8100.	Formatting deletes all data saved on the memory card. Be sure to select No and make copies of any images which need to be kept before formatting the memory card. Select Yes and press the  button to format the memory card.	21
 Out of memory.	Memory card is full.	<ul style="list-style-type: none"> • Choose smaller image size. • Delete images. • Insert new memory card. • Remove memory card and use internal memory. 	44 29, 140 20 20
 Image cannot be saved.	Error occurred while saving image.	Format internal memory or memory card.	172
	Camera has run out of file numbers.	Insert a new memory card or format internal memory or memory card.	20, 172
	Image cannot be used for welcome screen.	The following images cannot be registered as welcome screen. <ul style="list-style-type: none"> • Images captured at an Image mode setting of  3968 x 2232 • Images created using the small picture or crop functions that are 320 x 240 or smaller in size • Still images captured while recording high-definition or full high-definition movies 	159
	Insufficient space to save a copy.	Delete images from destination.	29, 140
 Album is full. No further pictures can be added.	Over 200 images have already been added to album.	<ul style="list-style-type: none"> • Remove some images from album. • Add to other albums. 	95 92
 Sound file cannot be saved.	A voice memo cannot be attached to this file.	<ul style="list-style-type: none"> • Voice memos cannot be attached to movies. • Select an image captured with COOLPIX S8100. 	– 118

Error Messages

Display	Problem	Solution	
i Image cannot be modified.	Cannot edit selected image.	<ul style="list-style-type: none"> Select images that support editing function. Movies cannot be edited. 	122 –
i Cannot record movie.	Time out error while saving movie on the memory card.	Choose memory card with faster write speed.	20
i Memory contains no images.	No images in the internal memory or memory card.	<ul style="list-style-type: none"> Remove the memory card from the camera to play back images saved in the camera's internal memory. To copy image from internal memory to memory card, press the MENU button. The copy screen will be displayed and images in the internal memory can be copied to memory card. 	20 119
	No images have been added to the selected album.	<ul style="list-style-type: none"> Add images to the album. Choose an album to which images are added. 	92 94
	No images are contained in the category selected in auto sort mode.	Select the category containing the sorted images.	102
i File contains no image data.	File not created with the COOLPIX S8100.	File cannot be viewed on this camera. View file using a computer or the devices used to create or edit this file.	–
i This file cannot be played back.			
i All images are hidden.	No images available for a slide show.	–	113
i This image cannot be deleted.	Image is protected.	Disable protection.	114
i Travel destination is in the current time zone.	Destination in same time zone as home.	–	162

Display	Problem	Solution	
 Mode dial is not in the proper position.	The mode dial is not set to the correct position.	Rotate the mode dial to select the desired mode.	42
 Flash is not fully raised.	Flash is held down by fingers and other objects.	Do not hold down the flash.	24
Lens error 	Lens error.	Turn camera off and then on again. If error persists, contact retailer or Nikon-authorized service representative.	22
 Communications error	Error occurred during communication with printer.	Turn camera off and reconnect USB cable.	152
System error 	Error has occurred in camera's internal circuitry.	Turn camera off, remove and reinsert battery, and turn camera on. If error persists, contact retailer or Nikon-authorized service representative.	12, 17
 Printer error: check printer status.	Printer error.	Check printer. After solving the problem, select Resume and press the  button to resume printing.*	–
 Printer error: check paper	Specified size of paper is not loaded in printer.	Load the specified paper, select Resume , and press the  button to resume printing.*	–
 Printer error: paper jam	Paper has jammed in printer.	Remove the jammed paper, select Resume , and press the  button to resume printing.*	–
 Printer error: out of paper	No paper is loaded in printer.	Load the specified paper, select Resume , and press the  button to resume printing.*	–
 Printer error: check ink	Ink error.	Check ink, select Resume , and press the  button to resume printing.*	–
 Printer error: out of ink	Running out of ink or ink cartridge is empty.	Replace ink cartridge, select Resume , and press the  button to resume printing.*	–

Error Messages



Display	Problem	Solution	
 Printer error: file corrupt	An error caused by the image file has occurred.	Select Cancel and press the  button to cancel printing.	-

* See the documentation provided with your printer for further guidance and information.

Troubleshooting

If the camera fails to function as expected, check the list of common problems below before consulting your retailer or Nikon-authorized service representative.

Display, Settings, and Power Supply





Problem	Cause/Solution	
The battery inserted in the camera cannot be charged.	<ul style="list-style-type: none">• Confirm all connections.	14
	<ul style="list-style-type: none">• Off is selected for Charge by computer in the setup menu.	174
	<ul style="list-style-type: none">• When charging by connecting the camera to a computer, battery charging stops when the camera is turned off.	150
	<ul style="list-style-type: none">• When charging by connecting the camera to a computer, battery charging stops when the computer is suspended (sleeping), and the camera may turn off.	150
	<ul style="list-style-type: none">• Depending upon computer specifications, settings, and status, charging the battery inserted in the camera may not be possible via computer connection.	–
Camera cannot be turned on.	<ul style="list-style-type: none">• Battery is exhausted.	22
	<ul style="list-style-type: none">• The camera cannot be turned on while connected to an electrical outlet via the Charging AC Adapter.	14
Camera turns off without warning.	<ul style="list-style-type: none">• Battery is exhausted.	22
	<ul style="list-style-type: none">• Camera has turned off automatically to save power.	171
	<ul style="list-style-type: none">• The camera and battery may not perform properly if they are cold.	181
	<ul style="list-style-type: none">• The camera turns off if the Charging AC Adapter is connected while the camera is on.	14
	<ul style="list-style-type: none">• The camera turns off if the USB cable connecting it to a computer or printer is disconnected. Reconnect the USB cable.	146, 148, 152
<ul style="list-style-type: none">• Inside of the camera has become hot. Leave the camera off until the inside of the camera has cooled, and then try turning it on again.	–	
Monitor is blank.	<ul style="list-style-type: none">• Camera is off.	17
	<ul style="list-style-type: none">• Standby mode for saving power: press the power switch, shutter-release button, or the  button, or rotate the mode dial.	8, 11, 17
	<ul style="list-style-type: none">• When flash lamp blinks, wait until flash has charged.	32
	<ul style="list-style-type: none">• Camera and computer are connected via USB cable.	146
	<ul style="list-style-type: none">• Camera and TV are connected via A/V cable or HDMI cable.	143
Monitor is hard to read.	<ul style="list-style-type: none">• Adjust monitor brightness.	163
	<ul style="list-style-type: none">• Monitor is dirty. Clean monitor.	182

Shooting



Problem	Cause/Solution	
Cannot switch to shooting mode.	Disconnect HDMI cable or USB cable.	143, 146, 152
No image captured when the shutter-release button is pressed.	<ul style="list-style-type: none"> When camera is in playback mode, press the  button or shutter-release button. When menus are displayed, press the MENU button. Battery is exhausted. When flash lamp blinks, flash is charging. 	8, 28 10 22 32
Camera cannot focus.	<ul style="list-style-type: none"> The intended subject is one with which autofocus does not perform well. Set AF assist in the setup menu to Auto. Turn camera off and then on again. 	27 169 17
Images are blurred.	<ul style="list-style-type: none"> Use flash. Enable vibration reduction or motion detection. Use BSS (best shot selector). Use tripod and self-timer. 	30 166, 168 75 33
Bright specks appear in images captured with flash.	Flash is reflecting off particles in air. Set the flash mode setting to  (off).	31
Flash does not fire.	<ul style="list-style-type: none"> Flash mode is set to  (off). Scene mode with which the flash does not fire is selected. Flash is not fully raised. Do not hold down the flash. Another function that restricts flash is enabled. 	30 58 24 78
Digital zoom cannot be used.	<ul style="list-style-type: none"> Digital zoom is set to Off in the setup menu. Digital zoom is not available in the following situations. <ul style="list-style-type: none"> When using the scene auto selector, , (night landscape), , (night portrait), , (backlighting) (when HDR is set to On), and Portrait scene modes When using subject tracking mode When continuous shooting mode is set to Multi-shot 16 When using  (smile timer) 	169 56, 58, 59, 60, 61 70 75 34

Troubleshooting

Problem	Cause/Solution	
Image mode not available.	<ul style="list-style-type: none"> Another function that restricts the Image mode option is enabled. 	78
	<ul style="list-style-type: none"> Available image modes differ according to the current shooting mode. 	44
No sound when shutter is released.	Off is selected for Sound settings>Shutter sound in setup menu. No sound is heard with some shooting modes and settings, even when On is selected.	170
AF-assist illuminator does not light.	Off is selected for the AF assist option in the setup menu. AF-assist illuminator may not light depending on the position of the focus area or the current scene mode, even when Auto is selected.	58-67, 169
Images appear smeared.	Lens is dirty. Clean lens.	182
Colors are unnatural.	White balance or hue is not adjusted properly.	37, 46, 65
Randomly spaced bright pixels ("noise") appear in image.	Shutter speed is too slow or ISO sensitivity is high as the subject is dark. Noise can be reduced by: <ul style="list-style-type: none"> Using flash. Specifying a lower ISO sensitivity setting. 	30 49
Images are too dark (underexposed).	<ul style="list-style-type: none"> The flash mode is set to  (off). Flash window is blocked. Subject is beyond flash range. Adjust exposure compensation. Increase ISO sensitivity. Subject is backlit. Select  (backlighting) or set the flash mode to  (fill flash). 	30
		24 30 40, 41 49 30, 60
Images are too bright (overexposed).	Adjust exposure compensation.	40, 41
Unexpected results when flash set to  (auto with red-eye reduction).	When using  (auto with red-eye reduction) or  (night portrait) to take pictures using the flash, In-Camera Red Eye Fix may be applied to areas not affected by red-eye. Use any shooting mode other than  (night portrait), change the flash mode to any setting other than  (auto with red-eye reduction), and then try taking a picture again.	30, 59

Problem	Cause/Solution	
Saving images takes time.	It may take more time to save images in the following situations.	
	• When the noise reduction function is in operation.	31
	• When the flash mode is set to  (auto with red-eye reduction).	32
	• When taking pictures in the following scene modes.	
	-  (night landscape) 58 -  (night portrait) 59 -  (backlighting) (when HDR is set to On) 60 • When using continuous shooting mode. 73	

Playback

Problem	Cause/Solution	
File cannot be played back.	• File or folder was overwritten or renamed by computer or other make of camera.	–
	• The COOLPIX S8100 is not able to play back movies recorded with another make or model of digital camera.	140
Cannot zoom in on image.	Playback zoom cannot be used with movies, small pictures, or images that have been cropped to a size of 320 × 240 or smaller.	–
Cannot record or play back voice memos.	• Voice memos cannot be attached to movies.	140
	• Voice memos can only be attached to images captured with the COOLPIX S8100. Voice memos attached to images using another camera cannot be played back on this camera.	118
Cannot use quick retouch, D-Lighting, skin softening, small picture, or crop.	• These options cannot be used with movies.	140
	• Images captured at an Image mode setting of  3968 × 2232 and still images captured while recording high-definition or full high-definition movies cannot be edited.	44
	• Select images that support quick retouch, D-Lighting, skin softening, small picture, or crop.	123
	• The COOLPIX S8100 is not able to edit images captured with another make or model of digital camera.	122

Problem	Cause/Solution	
<p>Images not displayed on television.</p>	<ul style="list-style-type: none"> • Video mode or HDMI is not correctly set in the TV settings setup menu. 173 • Both an HDMI cable and an audio/video cable, or both an HDMI cable and a USB cable are connected. 143, 146 • Memory card contains no images. Replace the memory card. Remove the memory card to play back images from the internal memory. 20 	
<p>Album icons are reset to their default icons, images added to albums cannot be displayed in favorite pictures mode.</p>	<p>Data saved in the internal memory or on the memory card may not be played back correctly if overwritten by a computer.</p>	<p>–</p>
<p>The saved images are not displayed in auto sort mode.</p>	<ul style="list-style-type: none"> • The desired image was sorted to a category other than the category currently displayed. 100 • Images saved by a camera other than the COOLPIX S8100 and images copied using the Copy option cannot be displayed in auto sort mode. 102 • Images saved in the internal memory or on the memory card may not be played back correctly if overwritten by a computer. – • Up to 999 images and movies in total can be added to each category. If the desired category already contains 999 images or movies in total, new images or movies cannot be added. 102 	
<p>Nikon Transfer 2 does not start when camera is connected.</p>	<ul style="list-style-type: none"> • Camera is off. 17 • Battery is exhausted. 22 • USB cable is not correctly connected. 146 • Camera is not recognized by the computer. – • Confirm system requirements. 145 • Computer is not set to start Nikon Transfer 2 automatically. 149 <p>For more information on Nikon Transfer 2, refer to help information contained in ViewNX 2.</p>	
<p>The PictBridge startup screen is not displayed when the camera is connected to a printer.</p>	<p>With some PictBridge-compatible printers, the PictBridge startup screen may not be displayed and it may be impossible to print images when Auto is selected for the Charge by computer option in the setup menu. Set the Charge by computer option to Off and reconnect the camera to the printer.</p>	<p>174</p>

Problem	Cause/Solution	
Images to be printed are not displayed.	<ul style="list-style-type: none"> • Memory card contains no images. Replace the memory card. • Remove the memory card to print images from the internal memory. 	20
Cannot select paper size with camera.	Paper size cannot be selected from the camera in the following situations, even when printing from a PictBridge-compatible printer: <ul style="list-style-type: none"> • The printer does not support the paper sizes specified by the camera. • The printer automatically selects the paper size. 	153, 154 –

Specifications

Nikon COOLPIX S8100 Digital Camera

Type	Compact digital camera
Effective pixels	12.1 million
Image sensor	$\frac{1}{2.3}$ -in. type CMOS; approx. 12.75 million total pixels
Lens	10 \times optical zoom, NIKKOR lens
Focal length	5.4-54.0mm (angle of view equivalent to that of 30-300 mm lens in 35mm [135] format)
f/-number	f/3.5-5.6
Construction	10 elements in 8 groups
Digital zoom	Up to 4 \times (angle of view equivalent to that of approx. 1200 mm lens in 35mm [135] format)
Vibration reduction	Combination of lens-shift and electronic VR (still pictures) Lens-shift (movies)
Autofocus (AF)	Contrast-detect AF
Focus range (from lens)	<ul style="list-style-type: none">• [W]: Approx. 50 cm (1 ft. 8 in.) to ∞, [T]: Approx. 1 m (3 ft. 4 in.) to ∞• Macro mode: Approx. 1 cm (0.4 in.) to ∞ (wide-angle position)
Focus-area selection	Face priority, auto (9-area automatic selection), manual with 99 focus areas, center, subject tracking
Monitor	7.5 cm (3-in.), approx. 921k-dot, wide viewing angle TFT LCD with anti-reflection coating and 5-level brightness adjustment
Frame coverage (shooting mode)	Approx. 97% horizontal and 97% vertical
Frame coverage (playback mode)	Approx. 100% horizontal and 100% vertical
Storage	
Media	Internal memory (approx. 102 MB), SD/SDHC/SDXC memory card
File system	DCF, Exif 2.2, and DPOF compliant
File formats	Still pictures: JPEG Sound files (Voice Memo): WAV Movies: MOV (Video: MPEG-4 AVC/H.264, Audio: AAC stereo)
Image size (pixels)	<ul style="list-style-type: none">• 12M (High) [4000 \times 3000 ★]• 12M [4000 \times 3000]• 8M [3264 \times 2448]• 5M [2592 \times 1944]• 3M [2048 \times 1536]• PC [1024 \times 768]• VGA [640 \times 480]• 16:9 [3968 \times 2232]

ISO sensitivity (Standard output sensitivity)	<ul style="list-style-type: none"> • ISO 160, 200, 400, 800, 1600, 3200 • Auto (auto gain from ISO 160 to 800) • Fixed range auto (ISO 160 to 400) • Sport continuous (ISO 160 to 3200)
Exposure	
Metering	256-segment matrix, center-weighted, spot (digital zoom 2x or more)
Exposure control	Programmed auto exposure with motion detection and exposure compensation (-2.0 to +2.0 EV in steps of 1/3 EV)
Shutter	Mechanical and CMOS electronic shutter
Speed	<ul style="list-style-type: none"> • 1/2000 -2 s • 1/4000 -1/120 s (sport continuous mode) • 4 s (Fireworks show scene mode)
Aperture	Electronically-controlled ND filter (-2 AV) selection
Range	2 steps (f/3.5 and f/7 [W])
Self-timer	Can be selected from 10 and 2 seconds duration, smile timer
Built-in flash	
Range (approx.) (ISO sensitivity: Auto)	[W]: 0.5 to 4.0 m (1 ft. 8 in. to 13 ft.) [T]: 0.5 to 2.5 m (1 ft. 8 in. to 8 ft. 2 in.)
Flash control	TTL auto flash with monitor preflashes
Interface	Hi-Speed USB
Data transfer protocol	MTP, PTP
Video output	Can be selected from NTSC and PAL
HDMI output	Can be selected from Auto , 480p , 720p , and 1080i
I/O terminal	Audio/video (A/V) output; digital I/O (USB) HDMI mini connector (Type C) (HDMI output)
Supported languages	Arabic, Chinese (Simplified and Traditional), Czech, Danish, Dutch, English, Finnish, French, German, Greek, Hungarian, Indonesian, Italian, Japanese, Korean, Norwegian, Polish, Portuguese, Russian, Spanish, Swedish, Thai, Turkish
Power sources	One Rechargeable Li-ion Battery EN-EL12 (supplied) AC Adapter EH-62F (available separately)
Charging time	Approx. 3 hours and 50 minutes (when using Charging AC Adapter EH-68P/EH-68P (AR) and when no charge remains)
Battery life (EN-EL12)	Still pictures*: Approx. 210 shots Movies: Approx. 1 h 20 min (HD 1080p ★)
Tripod socket	1/4 (ISO 1222)
Dimensions (W × H × D)	Approx. 104.0 × 59.2 × 29.9 mm (4.1 × 2.4 × 1.2 in.) (excluding projections)
Weight	Approx. 209 g (7.4 oz) (including battery and SD memory card)

Specifications

Operating environment

Temperature	0 to 40 °C (32 to 104 °F)
Humidity	Less than 85 % (no condensation)

- Unless otherwise stated, all figures are for a camera with a fully-charged Rechargeable Li-ion Battery EN-EL12 operated at an ambient temperature of 25 °C (77 °F).
- * Based on Camera and Imaging Products Association (CIPA) standards for measuring the life of camera batteries. Measured at 23 (±2) °C (73 (±4) °F); zoom adjusted with each shot, flash fired with every other shot, image mode set to  4000 × 3000. Battery life may vary depending on shooting interval and length of time menus and images are displayed.

Rechargeable Li-ion Battery EN-EL12

Type	Rechargeable lithium-ion battery
Rated capacity	DC 3.7 V, 1050 mAh
Operating temperature	0 to 40 °C (32 to 104 °F)
Dimensions (W × H × D)	Approx. 32 × 43.8 × 7.9 mm (1.3 × 1.7 × 0.3 in.)
Weight	Approx. 22.5 g (0.8 oz) (excluding terminal cover)

Charging AC Adapter EH-68P/EH-68P (AR)

Rated input	AC 100-240 V, 50/60 Hz, 0.065-0.04 A
Rated capacity	6.5–9.6 VA
Rated output	DC 5.0 V, 0.5 A
Operating temperature	0 to 40 °C (32 to 104 °F)
Dimensions (W × H × D)	EH-68P: Approx. 55 × 22 × 65 mm (2.2 × 0.9 × 2.6 in.) EH-68P (AR): Approx. 55 × 51.6 × 66 mm (2.2 × 2.0 × 2.6 in.)
Weight	EH-68P: Approx. 60 g (2.1 oz) EH-68P (AR): Approx. 65 g (2.3 oz)

Specifications

Nikon will not be held liable for any errors this manual may contain. The appearance of this product and its specifications are subject to change without notice.

Supported Standards

- **DCF:** Design Rule for Camera File System is a standard widely used in the digital camera industry to ensure compatibility among different makes of camera.
- **DPOF:** Digital Print Order Format is an industry-wide standard that allows images to be printed from print orders saved on memory cards.
- **Exif version 2.2:** This camera supports Exchangeable image file format (Exif) version 2.2 for digital still cameras, a standard that allows information saved with photographs to be used for optimal color reproduction when images are output from Exif-compliant printers.
- **PictBridge:** A standard developed cooperatively by the digital camera and printer industries, allowing photographs to be output directly to a printer without connecting the camera to a computer.

Index

Symbols

AE/AF-L 69

(apply selection) button 9

(movie-record) button 8

T (tele) 25

W (wide) 25

Exposure compensation 41

Auto mode 22

Auto sort mode 100

Backlighting 60

MENU button 8, 10, 43, 90, 108, 132, 158

Continuous shooting mode 73, 75

Delete button 9, 29, 118, 140

Favorite pictures mode 92

Flash mode 31

List by date mode 104

Macro mode 36

Movie menu 132

Night landscape 58

Night portrait 59

Playback button 8, 28

Playback menu 107

Playback mode 28

Playback zoom 88

Scene 55

Scene Auto Selector 56

Self timer 33

Setup 157

Shooting menu 43

Subject tracking mode 70, 72

Thumbnail playback 85, 87

A

AC adapter 183

AF area mode 50

AF assist 169

Album 97

Aperture 26

Aperture value 26

Audio/video cable 143, 183

Audio/video-in jack 143

Auto 30, 46

Auto mode 22

Auto off 171

Auto sort menu 103

Auto sort mode 100

Autofocus 36, 54, 135

Autofocus mode 54, 72, 135

AV cable 143

B

Backlighting 60

Battery 12, 14, 161

Battery chamber 5

Battery charger 16, 183

Battery latch 5, 12

Battery level 22

Battery-chamber/memory card slot cover

12, 20

Beach 62

Best shot selector 76

Blink warning 175, 176

Brightness 163

BSS 76

Button sound 170

C

Calendar display 87

Center-weighted 48

Charge by computer 174

Charge lamp 5, 15, 150

Charger 14, 183

Charging AC Adapter 14, 183

Choose key picture 121

Close-up 64

Cloudy 46

Compression ratio 44

Computer 145

Connector cover 5

Continuous menu 75

Continuous shooting mode 73

Copy 67

Copying images 119

Creative slider 38

Crop 128

D

Date 18, 160

Date imprint 165

Daylight 46

Daylight saving time 18, 161

Delete 29, 84, 118, 140

Digital zoom 25, 169

Direct print 151

D-Lighting 125

DPOF 201

DPOF print 156

DSCN 185

Dusk/dawn  63

E

EH-68P/EH-68P (AR) 14

EN-EL12 12, 14

Exposure compensation 37, 41

Extension 185

Eyelet for camera strap 5

F

Face detection 52

Face priority 50

Favorite pictures 92

Favorite pictures menu 96

Favorite pictures mode 94

File name 185

Fill flash 30

Fireworks show  66

Firmware version 179

Fixed range auto 49

Flash 30, 46

Flash lamp 32

Flash mode 30

Flash off 30

Fluorescent 46

Focus 26, 50

Focus indicator 6

Focus lock 51

Folder name 185

Food  65

Format internal memory 172

Format memory card 21, 172

Formatting 21, 172

FSCN 185

Full-frame playback 28, 80

Full-time AF 54, 135

H

HDMI cable 143

HDMI device control 173

HS movie 137, 139

Hue 37

I

Identifier 185

Image copy 119

Image mode 44, 45

Image review 163

Image size 44

Incandescent 46

Internal memory 20

Internal memory indicator 23

ISO sensitivity 31, 49

J

JPG 185

L

Landscape  61

Language 173

Lens 4, 198

Lens cover 4

List by date menu 106

List by date mode 104

M

Macro mode 36

Matrix 48

Maximum movie length 135

Memory capacity 22



Memory card 20, 184

Memory card slot 20

Metering 48

Microphone 4
 Monitor 6, 182
 Monitor settings 163
 More on Shooting 42
 Motion detection 168
 MOV 185
 Movie Editing 141
 Movie menu 132
 Movie options 132
 Movie playback 140
 Movie recording 129
 Movie-record button 8
 Multi-shot 16 76
 Museum  66



N

Night landscape  58
 Night portrait  59
 Nikon Transfer 2 145, 146
 Number of exposures remaining 22, 45

O

Optical zoom 25
 Optional accessories 183
 Output connector 143

P

Panorama assist  67, 68
 Panorama Maker 5 145, 149
 Paper size 153, 154
 Party/indoor  62
 Photo info 163
 PictBridge 151, 201
 Playback 28, 85, 87, 88, 118, 140
 Playback menu 107
 Playback mode 28
 Playback mode menu 90
 Playback zoom 88
 Portrait  61
 Power 17, 18, 22
 Power switch 8, 17, 18, 22
 Power-on lamp 8, 17, 18, 22
 Preset manual 47

Pre-shooting cache 77
 Print 109, 153, 154
 Print set 109
 Print set date option 110, 112
 Printer 151
 Protect 114



Q

Quick retouch 124

R

Rechargeable battery 183
 Rechargeable Li-ion battery 12, 14, 183
 Recording movies 129
 Recording slow motion movies 137
 Red-eye reduction 30, 32
 Remove from favorites 95
 Reset all 177
 Rotary multi selector 9
 Rotate image 116
 RSCN 185

S

Scene auto selector 56
 Scene auto selector  56
 Scene mode 55, 58
 Self-timer 33
 Self-timer lamp 33
 Sequence display options 121
 Setup menu 157
 Shooting 22, 24, 26
 Shooting information 82
 Shooting menu 43
 Shutter sound 170
 Shutter speed 26
 Shutter-release button 8, 11, 26
 Single AF 54, 135
 Skin softening 126
 Slide show 113
 Slow sync 30
 Small picture 127
 Snow  62
 Sound settings 170

Speaker 4
Sport continuous 76
SSCN 185
Strap 11
Subject tracking menu 72
Subject tracking mode 70
Sunset  63

I

Television 143
Thumbnail display 85
Thumbnail playback 85
Time difference 162
Time zone 160, 162
Tripod socket 5, 199
TV 143
TV Settings 173

U

USB cable 146, 152, 183
USB/audio/video output connector 145,
146

V

Vibration reduction 166
Video mode 173
ViewNX 2 145, 149
Voice memo 117
Volume 118, 140

W

WAV 185
Welcome screen 159
White balance 46
Wind Noise Reduction 136

Z

Zoom control 8, 140
Zoom in 25
Zoom out 25



A series of horizontal dashed lines spanning the width of the page, providing a guide for handwriting practice. There are 15 lines in total, evenly spaced from the top of the page down to just above the footer.

Nikon

No reproduction in any form of this manual, in whole or in part (except for brief quotation in critical articles or reviews), may be made without written authorization from NIKON CORPORATION.



NIKON CORPORATION

© 2010 Nikon Corporation

CT0103(11)
6MM86211-03