

**POWER8**  
**workshop**  
*User Manual*

## THANK YOU

Thank you for investing in a CEL power tool. The **POWER8workshop** has been engineered and made to demanding high quality standards, ease of operations and safety have taken a major role in development. Proper care of your **POWER8workshop** will give you years of trouble-free use.

Normal wear and tear, including accessory wear, is not covered under guarantee. The product is guaranteed for **domestic use** against manufacturing faults for a period of 12 months (for additional guarantee period (if any) please refer to the store or agent from which you purchased the product or contact the nearest authorized dealer). This product is not guaranteed for HIRE purpose.

If you have any questions, please contact us at:  
**[service@POWER8workshop.com](mailto:service@POWER8workshop.com)** Tel: **08453 88 97 69**

It is possible to; download updated owner manuals, view demonstration video and find information about new products at: **[www.POWER8workshop.com](http://www.POWER8workshop.com)**

**Warning:** User must read and understand the user manual before using this product to reduce the risk of injury. Failure to follow all instructions may result in electric shock, fire and/or serious personal injury. The tool must be used only for its prescribed purpose. Any use other than those mentioned in this manual will be considered a case of misuse. The manufacturer shall NOT be liable for any damage or injury resulting from such cases of misuse.



# Contents

## Safety

1. Description of Symbols
2. Getting Started
  - 2.1 General Safety Instructions
  - 2.2 Tool Use and Care - Service

## Power Management

3. POWERhandle
  - 3.1 POWERhandle - Specifications and Know Your Products
  - 3.2 POWERhandle - Additional Safety Rules
  - 3.3 POWERhandle - Operating Instructions
  - 3.4 POWERhandle - Multi-Purpose Button (MPB)
  - 3.5 POWERhandle - Maintenance
4. Charging
  - 4.1 Charging - Specifications and Know Your Products
  - 4.2 Charging - Additional Safety Rules
  - 4.3 Charger Dock - Operating Instructions
  - 4.4 Charger - Secondary Charging Point (SCP)

## Handheld Power Tools

5. Drill/Driver
  - 5.1 Drill/Driver - Specifications and Know Your Product
  - 5.2 Drill/Driver - Additional Safety Rules
  - 5.3 Drill/Driver - Operating Instructions
  - 5.4 Drill/Driver - Maintenance
  - 5.5 Drill/Driver - Notes
6. Circular Saw
  - 6.1 Circular Saw - Specifications and Know Your Product
  - 6.2 Circular Saw - Additional Safety Rules
  - 6.3 Circular Saw - Operating Instructions
  - 6.4 Circular Saw - Maintenance

## Handheld Power Tools (*continue*)

- 7. Jigsaw
  - 7.1 Jigsaw - Specifications and Know Your Product
  - 7.2 Jigsaw - Additional Safety Rules
  - 7.3 Jigsaw - Operating Instructions
  - 7.4 Jigsaw - Maintenance
  
- 8. Halogen Light
  - 8.1 Halogen Light - Specifications and Know Your Product
  - 8.2 Halogen Light - Operating Instructions
  - 8.3 Halogen Light - Maintenance

## Bench top Functions

- 9. Case
  - 9.1 Know Your Product
  - 9.2 Post and Accessory Cases Storage and Release
  
- 10. Table Saw
  - 10.1 Table Saw - Specifications and Know Your Product
  - 10.2 Table Saw - Additional Safety Rules
  - 10.3 Table Saw - Assembly
  - 10.4 Table Saw - Operating Instructions
  - 10.5 Table Saw - Maintenance
  
- 11. Drill Press
  - 11.1 Drill Press - Specifications and Know Your Product
  - 11.2 Drill Press - Additional Safety Rules
  - 11.3 Drill Press - Assembly
  - 11.4 Drill Press - Operating Instructions
  - 11.5 Drill Press - Maintenance

## **Bench top Functions (*continue*)**

- 12. Scroll Saw
  - 12.1 Scroll Saw - Specifications and Know Your Product
  - 12.2 Scroll Saw - Additional Safety Rules
  - 12.3 Scroll Saw - Assembly
  - 12.4 Scroll Saw - Operating Instructions
  - 12.5 Scroll Saw - Maintenance
  
- 13. Table Light
  - 13.1 Specifications and Know Your Product
  - 13.2 Table Light Operating Instructions

## **Others**

- 14. Spirit Level and Protractor
  - 14.1 Post and Protractor Know Your Product
  - 14.2 Post and Protractor Operating Instructions
  
- 15. Trouble Shooting
  
- 16. Additional Parts and Accessories

# Description of Symbols

1.0

The safety and International symbols and pictographs that appear on this product, in the owner's manual and rating plate, represent important information about the product or instructions on its use.



Wear hearing protection.  
Wear eye protection.  
Wear breathing protection.



Always change the battery pack between temperatures 0°C to 40°C (32°F to 104°F).



Read the manual.



Do not burn.



Warning.



Recycle unwanted materials instead of disposing of them as waste. All tools, hoses and packaging should be sorted, taken to the local recycling center and disposed of in an environmentally safe way.



Do not dispose of the batteries. Return exhausted batteries to your local collection or recycling point.



For indoor use only.



Do not expose to water



Keep your hands away from blade or working area.



Contains Nickel-cadmium batteries. Battery must be recycled or disposed of properly



Double insulation.

## Work area

- a) **Keep your work area clean and well lit.** Cluttered benches and dark areas invite accidents.
- b) **Do not operate power tools in explosive atmospheres, such as in the presence of flammable liquids, gases, or dust.** Power tools create sparks which may ignite the dust or fumes.
- c) **Keep bystanders, children, and visitors away while operating a power tool.** Distractions can cause you to lose control.

## Electrical safety

- a) Power tool plugs must match the outlet. Never modify the plug in any way. Do not use any adaptor plugs with earthed (grounded) power tools.
- b) Avoid body contact with earthed or grounded surfaces such as pipes, radiators, ranges and refrigerators.
- c) Do not expose power tools to rain or wet conditions.
- d) Handle the cord carefully. Never use the cord for carrying, pulling or unplugging the power tool. Keep cord away from heat, oil, sharp edges or moving parts.
- e) When operating a power tool outdoors, use an extension cord suitable for outdoor use. Use of a cord suitable for outdoor use reduces the risk of electric shock.

## Personal safety

- a) Stay alert, watch what you are doing and use common sense when operating a power tool. Do not use tool when tired or under the influence of drugs, alcohol or medication. A moment of inattention while operating power tools may result in serious personal injury.
- b) Dress properly. Do not wear loose clothing or jewellery. Contain long hair. Keep your hair, clothing and gloves away from moving parts. Loose clothes, jewellery, or long hair can be caught in moving parts.
- c) Remove adjusting keys or wrenches before turning the tool on. A wrench or a key that is left attached to a rotating part of the tool may result in personal injury.
- d) Do not overreach. Keep proper footing and balance at all times. Proper footing and balance enables better control of the tool in unexpected situations.
- e) Use safety equipment. Always wear eye protection. Dust mask, non-skid safety shoes, hard hat, or hearing protection must be used for appropriate conditions.
- f) Avoid accidental starting. Ensure the switch is in the off-position before plugging. Carrying power tools with your finger on the switch or plugging in power tools that have the switch on invites accidents.
- g) If devices are provided for the connection of dust extraction and collection facilities, ensure that these are connected and properly used. Use of these devices can reduce dust-related hazard.

## Tool use and care

**a) Use clamps or other practical ways to secure and support the workpiece to a stable platform.** Holding the work by hand or against your body is unstable and may lead to loss of control.

**b) Do not force tool.** Use the correct tool for your application. The correct tool will do the job better and safer at the rate for which it is designed.

**c) Do not use the tool if switch does not turn it on or off.** Any tool that cannot be controlled with the switch is dangerous and must be repaired.

**d) Disconnect the plug from the power source before making any adjustments, changing accessories, or storing power tools.** Such preventive safety measures reduce the risk of starting the power tools accidentally.

**e) Store idle tools out of reach of children and other untrained persons.** Tools are dangerous in the hands of untrained users.

**f) Maintain tools with care.** Keep cutting tools sharp and clean. Properly maintained tools, with sharp cutting edges are less likely to bind and are easier to control.

**g) Check for misalignment or binding of moving parts, breakage of parts, and any other condition that may affect the tools operation.** If damaged, have the tool serviced before using. Many accidents are caused by poorly maintained tools.

**h) Only use accessories that are recommended by the manufacturer for your model.** Accessories that may be suitable for one tool, may become hazardous when used on another tool.

## Service

**a) Tool service must be performed only by qualified repair personnel.** Service or maintenance performed by unqualified personnel could result in a risk of injury.

**b) When servicing a tool, only use identical replacement parts.** Follow instructions in the Maintenance section of this manual. Use of unauthorized parts or failure to follow Maintenance instructions may create a risk of electric shock or injury.



***POWER8***  
***workshop***  
***3. POWERhandle***

## **Specifications**

Voltage:	18V
Batteries:	15 x 1.2v 1.5Ah Ni-Cd
Charging time:	1 Hour
Weight:	2.2 lbs (0.95 kg)

## **Know Your Product**

1. Rails
2. Product release latch
3. Rear soft grip
4. Battery cooling vent
5. Electronic coupling
6. Mechanical coupling parts
7. MPB (Multi-Purpose-Button)
8. Power Trigger
9. Front soft grip
10. Loop handle socket
11. Battery cooling vent.



## **Additional Safety Rules**

### **Battery Packs**

**a) Ensure the switch is in the off position before inserting the POWERhandle (battery).**

Inserting the battery pack into power tools that have the switch on invites accidents.

**b) A battery operated tool with integral batteries or a separate battery pack must be recharged only with the specified charger for the battery.** A charger that may be suitable for one type of battery may create a risk of fire when used with another battery.

**c) Use battery operated tool only with specifically designated battery pack.** Use of any other batteries may create a risk of fire.

**d) The battery pack for this tool has been shipped in a low charge condition.** You should charge the battery pack fully before use.

**e) Avoid conducting short charges.** Make sure that the battery is fully charged every time by allowing the charger to complete its full charging cycle.

**f) Never allow the drill to come to a complete standstill before recharging.** The battery should be placed on charge whenever it is noticeably running down or the drill no longer performs a task it previously performed.

**g) To ensure the longest battery life and best battery performance, always charge the battery when the air temperature is between 18-24°C (65-75°F).** Do not charge or store the battery pack below 4°C (40°F), or above 40°C (104°F). This is important. Failure to observe this safety rule could cause serious damage to the battery

pack.

**h) Do not incinerate the battery pack even if it is seriously damaged or can no longer hold a charge.** The battery pack can explode in a fire.

**i) A small leakage of liquid from the battery pack may occur under extreme usage or temperature conditions.** This does not necessarily indicate a failure of the battery pack. However, if the outer seal is broken and this leakage comes into contact with your skin:

- Wash the affected area quickly with soap and water
- Neutralise the liquid with a mild acid such as lemon juice or vinegar

If the leakage gets into your eyes:

- Flush your eyes with clean water for a minimum of 10 minutes and seek immediate medical attention. Inform the medical staff that the liquid is a 25-35% solution of potassium hydroxide.5. Never attempt to open the battery pack for any reason. If the plastic housing of the battery pack breaks open or cracks, immediately discontinue its use and do not recharge it.

**j) Do not store or carry a spare battery pack in a pocket or toolbox or any other place where it may come into contact with metal objects.** The battery pack may be short circuited causing damage to the battery pack, burns or a fire.

**l) If the battery of the POWERhandle (battery pack) utilises nickel-cadmium cells, beware that cadmium is considered to be a toxic material.**

**k) Use an environmentally safe disposal unit at a municipal waste disposal centre to dispose of a damaged or worn out battery, or return it to your dealer.**

1. To fit the POWERhandle to a product, grip one in each hand and align the rails. Push the POWERhandle forward onto the product until it 'clicks' and will move no further. To ensure that it is fully assembled, try to pull them apart; they should be locked together.

2. To release a POWERhandle from a product, first pull the release slider down with your thumb whilst gripping the handle. Grip the product head with the other hand and pull the POWERhandle backwards. The handle should easily slide off the product.

All POWER8 components are connected and disconnected in this way; it is also necessary to slide the product release slider down to remove the POWERhandle from the charger dock.

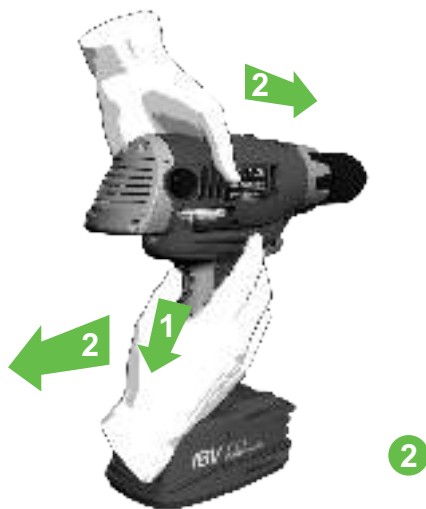

The MPB (Multi-Purpose-Button) will adapt its function to the requirements of the product attached to the POWERhandle.

For example when the POWERhandle is connected to;

The Drill/Driver:  
direction control

The Halogen Light:  
on / off / flashes (press trigger)

The Jigsaw and Circular Saw:  
safety button, pressed before the trigger is released.

The MPB has 3 normal positions; fully left, centred and fully right. It is not possible to move the MPB when the trigger is pulled and when the MPB is centred the trigger will be locked forward.

The trigger will also perform differently when the POWERhandle is attached to different products. Some products may require variable power, others a simple on/off. For example: the drill spindle speed is controlled by the amount the trigger is pulled, but the Circular Saw only requires on/off.



# **POWER8** *workshop*

## *4. Charging Dock and Secondary Charger (SCP)*

## Specifications

Input:	120V or 240V AC 50/60Hz 46W
Output:	18V DC 1.5A
Charging time:	1 Hour

## Know Your Product

Secondary  
Charger  
Point(SCP)

LED Display  
Charger Dock  
POWERhandle

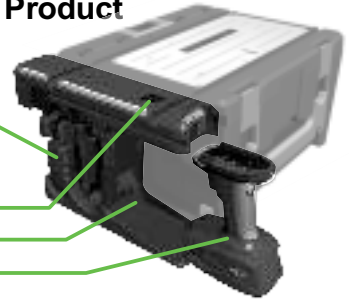

## Charging - Additional Safety Rules

## 4.2

1. Before using the charger (**Handle Dock**), read all the instructions and cautionary markings on the charger and battery pack (**POWERhandle**) as well as the instructions on using the battery pack.

2. This charger is designed for indoor use only. Do not charge your batteries outdoors.

3. DANGER: Do not allow any liquid to come into contact with the charger. There is a danger of electric shock.

4. The charger is not intended for any use other than charging the exact type of rechargeable battery pack as supplied with the charger. Any other use may result in the risk of fire, electric shock or electrocution.

5. To reduce the risk of an electric shock, unplug the charger from the power supply before attempting to clean it.

6. Do not disassemble the charger. Take it to an authorised service center when service or repair is required. Incorrect re-assembly may result in the risk of fire, electric shock or electrocution.

7. Do not pull on the lead of the charger to disconnect it from the power source. Do not carry the charger by the cable. Protect the cable from sharp objects, heat and oil; have it replaced if damaged.



The POWERhandle has been shipped in a low charge condition. You should charge the battery fully before use.

**WARNING.** Do not throw used POWERhandles into a fire or water; it could cause an explosion!

**NOTE.** It is necessary to slide down the product release latch in order to remove the POWERhandle from the charger dock, or from the tools.

To charge the POWERhandle slide it into the charger dock; the rails of the POWERhandle should be aligned with the rails of the charger dock. Slide the battery down until it “clicks” into position. Connect the mains plug to a suitable mains outlet.

LED's on the top of the charger dock will display the battery's condition. When the green LED is on, the case is correctly connected to the mains power. A green flashing LED means fast charging. When the red LED is on, the POWERhandle is fully charged

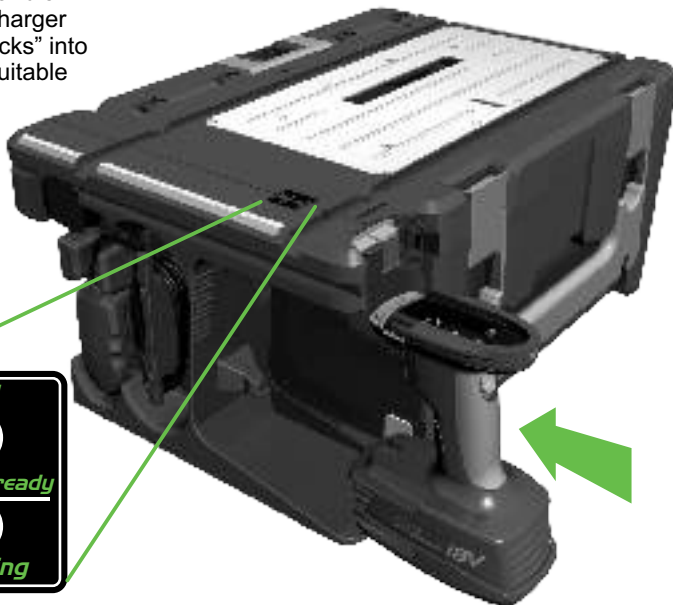
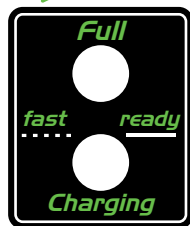

As well as the main charger dock the POWER8works is fitted with a secondary charger point(SCP). This allows a POWERhandle to be charged while a second POWERhandle is powering the POWER8workshop benchtop functions.

When the secondary charger point is removed from the charger dock, the dock will not charge a POWERhandle. The secondary charger point must be correctly replaced into the side of the charger dock to start charging the POWERhandle in the dock.

As soon as a POWERhandle is connected to the SCP, and the mains plug is connected to a suitable power source, it will start the charging cycle.

### **To obtain the best life for the battery:**

Never allow the battery to completely discharge; it should be placed on charge whenever it is noticeably running down, or the tool no longer performs a task it previously performed.

Avoid conducting short charges. Make sure that the battery is fully charged every time by allowing the charger to complete its full charging cycle.

Avoid allowing loose items like screws or nails etc. to be stored with battery packs as this may cause a fire or explosion.

Always unplug the charger when not in use and store in a dry, secure place. Avoid charging or storing your battery in temperatures below 0°C (32°F), and above 40°C (104°F).



***POWER8***  
***workshop***  
***5. Drill/Driver***

## Specifications

---

Voltage: 18V

---

No load speed: 0-350, 0-1,250 RPM

---

Torque settings: 20 Positions

---

Max drilling capacity:

Steel 1/2" (13 mm)

Wood 1 1/10" (28 mm)

Concrete 1/2" (13 mm)

---

Hammer impact frequency:

0-5,600, 0-20,000 min<sup>-1</sup>

---

Single Sleeve

Drill chuck capacity: 1/2" (13 mm) keyless

---

Double Sleeve

Drill chuck capacity: " (10 mm) keyless

---

Weight: (WS1-HD01) 4.3lbs (2.4 kg)

---

Weight: (WS1-LD01) 4.7lbs (2.1 kg)

---

## Know Your product

1. Variable power trigger/Stop
2. MPB(Direction selector/lock)
3. Soft grip
4. Motor cooling vents
5. Keyless chuck
6. 2 Speed gearbox selector
7. Torque/Hammer selector
8. Replaceable brush cover
9. Battery cooling vents
10. Handle release latch
11. Driver bit

**NOTE.** Hammer Mode is not available on drill model WS1-LD01



## Additional Safety Rules Cordless Drills & Drivers

**a)** Hold tool by insulated gripping surfaces when performing an operation where the drill bits may contact hidden wiring. Contact with a “live” wire will make exposed metal parts of the tool “live” and shock the operator.

**b)** Always wear safety goggles or eye protection when using this tool. Use a dust mask or respirator for applications which generate dust.

**c)** Secure the material being drilled. Never hold it in your hand or across your legs. Unstable support can cause the drill bit to bind causing loss of control and injury.

**d)** Position yourself to avoid being caught between the tool or side handle and walls or posts. Should the bit become bound or jammed in the work, the reaction torque of the tool could crush your hand or leg.

**e)** If the bit becomes bound in the workpiece, release the trigger immediately, reverse the direction of rotation and slowly squeeze the trigger to back out the bit. Be ready for a strong reaction torque. The drill body will tend to twist in the opposite direction as the drill bit is rotating.

**f)** Do not grasp the tool or place your hands too close to the spinning chuck or drill bit. Your hand may be injured.

**g)** When installing a drill bit, insert the shank of the bit well within the jaws of the chuck. If the bit is not inserted deep enough, the grip of the jaws over the bit is reduced and the loss of control is increased.

**h)** Do not use dull or damaged bits and accessories. Dull or damaged bits have a greater tendency to bind in the workpiece.

**i)** When removing the bit from the tool avoid contact with skin and use proper protective gloves when grasping the bit or accessory. Accessories may be hot after prolonged use. Check to see that keys and adjusting wrenches are removed from the drill before switching the tool on. Keys or wrenches can fly away at high velocity striking you or a bystander.

**j)** Do not run the drill while carrying it at your side. A spinning drill bit could become entangled with clothing and injury may result.

**WARNING!** Some dust created by power sanding, sawing, grinding, drilling and other construction activities contains chemicals known to cause cancer, birth defects or reproductive harm. Some examples of these chemicals are:

**a)** Lead from lead-based paints

**b)** Crystalline silica from bricks and cement and other masonry products, and

**c)** Arsenic and chromium from chemically treated lumber.

Your risk from these exposures varies, depending on how often you do this type of work. To reduce your exposure to these chemicals work in a well ventilated area, and work with approved safety equipment, such as dust masks that are specifically designed to filter out microscopic particles.

Use the MPB switch on the POWERhandle to select the direction of rotation, then pull the trigger. This trigger switch is an electronic variable speed control which enables the user to vary the speed continuously. The speed varies according to how far the trigger switch is depressed. The further it is depressed the faster the chuck will rotate and the lighter it is depressed, the slower it will rotate.

To stop the drill, release the trigger switch.

**NOTE.** You can only change the direction of the rotation of the drill using the forward / reverse switch when the trigger is NOT depressed.

Drilling uses the forward mode. The reverse mode is intended for the removal of screws.

## Drilling Positions

This symbol  indicates the **DRILLING MODE**. Used for all normal drilling (wood, aluminium, and steel) in this mode the clutch is deactivated.

This symbol  indicates the **HAMMER MODE**. (some models of this product have hammer function) This mode will activate the hammer action while drilling. For best results in hammer mode, set the gear selector to high gear.

**NOTE.** Hammer Mode is not available on the drill model WS1-LD01

## Torque Adjustment/Hammer Selection Collar

By rotating the torque adjustment / hammer selection collar behind the chuck, it is possible to adjust the torque to each of the 20 settings, or select hammer action setting.

**NOTE.** Hammer Mode is not available on the drill model WS1-LD01

The range of 20 torque settings allows better control when using the drill as a screwdriver as it prevents over-tightening of the screws.

The symbols circling the collar are used to indicate the level of torque. The larger the symbol or number on the collar, the higher torque and the larger the fastener which can be driven. To select any of the symbols, rotate the collar until the desired symbol aligns with the arrow head indicator on the housing.

## Speed Gearbox

The 2 Speed Gearbox allows you to select a gear with the optimum speed and torque to suit the application.

**NOTE.** When changing the gear selector ensure the drill is not operating.

To select the LOW gear (low speed, high torque setting), pull the gear selector back, always from the chuck. The word LOW will be displayed.

To select the HIGH gear (high speed, low torque setting), push the gear selector forward, towards the chuck. The word HIGH will be displayed.

## Inserting and Removing Cutting tools

### **For Two Sleeve Chucks**

Hold the rear sleeve of the chuck, turn the front sleeve in a direction which releases the jaws.

### **For Single Sleeve Chucks**

The drill is fitted with an auto spindle lock which means if you try and rotate the chuck by hand the spindle of the drill will automatically lock. You only need to grasp the chuck and rotate the chuck housing to remove or fit accessories.

This drill has a keyless chuck, hence the chuck key is not needed to secure a bit in the drill. Always set the MPB switch to the center, lock 'OFF' position, when installing and removing bits.

Open the chuck jaws by firmly holding the chuck housing and rotating the housing in an anti-clockwise direction. Open the jaws sufficiently to fit the desired accessory.

Ensure the accessory is fully inserted, so that the jaws of the chuck grip onto the flat section of the accessory.

To firmly clamp the accessory in the chuck, grasp the housing and rotate the chuck housing in a clockwise direction. Ensure the bit is retained firmly or the chuck jaws maybe damaged.

To remove the accessory, open the chuck jaws by firmly holding the housing and rotating the chuck housing in an anti clockwise direction.

Open the jaws sufficiently to remove the accessory.

## Drilling Metals

- 1) For maximum performance, use high speed steel bits for metal or steel drilling.
- 2) Ensure that the torque adjustment / hammer selection collar is in normal drilling mode.
- 3) Begin drilling at a very low speed to prevent the bit from slipping off the starting point.
- 4) Always clamp sheet metal.
- 5) Support thin metal with a block of wood to avoid distorting it.
- 6) Use a punch to mark the centre of the hole.
- 7) Use a suitable lubricant for the material you are working on.

### **Use:**

Oil  
Turpentine or paraffin  
Do not lubricate

### **For:**

Steel  
Aluminium  
Brass, copper or cast iron

## Drilling plastics and plastic coated chipboard

- a. Use high-speed drill bits
- b. See drilling wood



## Drilling wood

- 1) For maximum performance, use high speed steel bits for wood drilling.
- 2) Ensure that the mode selector is in normal drilling mode.
- 3) Begin drilling at a very low speed to prevent the bit from slipping off the starting point. Increase the speed of the drill as soon as the cutting tool is in the material.
- 4) When drilling through holes, place a block of wood behind the workpiece to prevent ragged or splintered edges on the back side of the hole.

## Drilling masonry

**NOTE.** Hammer Mode is not available on the WS1-LD01 drill product.

- 1) For maximum performance use carbide-tipped masonry impact bits when drilling holes in brick, tile, concrete etc.
- 2) Turn the torque collar to hammer mode, or drill if unavailable.
- 3) Apply light pressure and medium speed for best results in brick.
- 4) Apply additional pressure and high speed for hard materials such as concrete.
- 5) When drilling holes in tile, practice on a scrap piece to determine the best speed and pressure.

**WARNING.** Never attempt to lock the trigger switch in the on position, do not lock the trigger on jobs where your hammer drill may need to be stopped suddenly.

## All drilling operations

- 1) Mark off the centre of the hole using a centre punch or nail.
- 2) Don't force the drill, let it work at its own pace.
- 3) Keep the drill bit sharp.
- 4) Reduce pressure as the drill is about to break through the item being drilled.

# Drill/Driver-Maintenance 5.4

## Maintenance

- 1) Store the tool, instruction manual and accessories in a secure place. This way you will always have all the information and parts to hand.
- 2) Keep the tool's air vents unclogged and clean at all times.
- 3) Remove dust and dirt regularly. Cleaning is best done with compressed air or a rag.
- 4) Never use caustic agents to clean plastic.

**CAUTION.** Do not use cleaning agents to clean the plastic parts of the tool. A mild detergent on a damp cloth is recommended. Water must never come into contact with the tool.

## General Inspection

Regularly check that all the fixing screws are tight. They may vibrate loose over time.



***POWER8***  
***workshop***  
***6. Circular Saw***

## Specifications

Voltage:	18V
No load speed:	3,500 RPM
Cutting depth @ 0°:	1 <sup>9</sup> / <sub>16</sub> " (40mm)
Cutting depth @ 45°:	1" (26mm)
Blade diameter:	5 <sup>1</sup> / <sub>2</sub> " (140mm), 24 tooth TCT
Blade bore:	<sup>3</sup> / <sub>8</sub> " (10mm)
Blade kerf:	1 <sup>1</sup> / <sub>16</sub> " (18mm)
Weight:	7.3lbs (3.3 kg)

## Know Your Product

1. Power trigger/Stop
2. MPB (Safety lock)
3. Motor cooling vent
4. Hex key
5. Soft grip
6. Handle release latch
7. Blade lock bolt
8. Auxiliary handle
9. Saw dust exhaust
10. Battery cooling vent
11. Depth adjustment lock
12. Lower blade guard lever
13. Spindle lock
14. Bevel angle lock knob
15. 45° Bevel cut guide notch
16. Straight cut guide notch
17. Fence locking knob
18. Fence angle lock knob

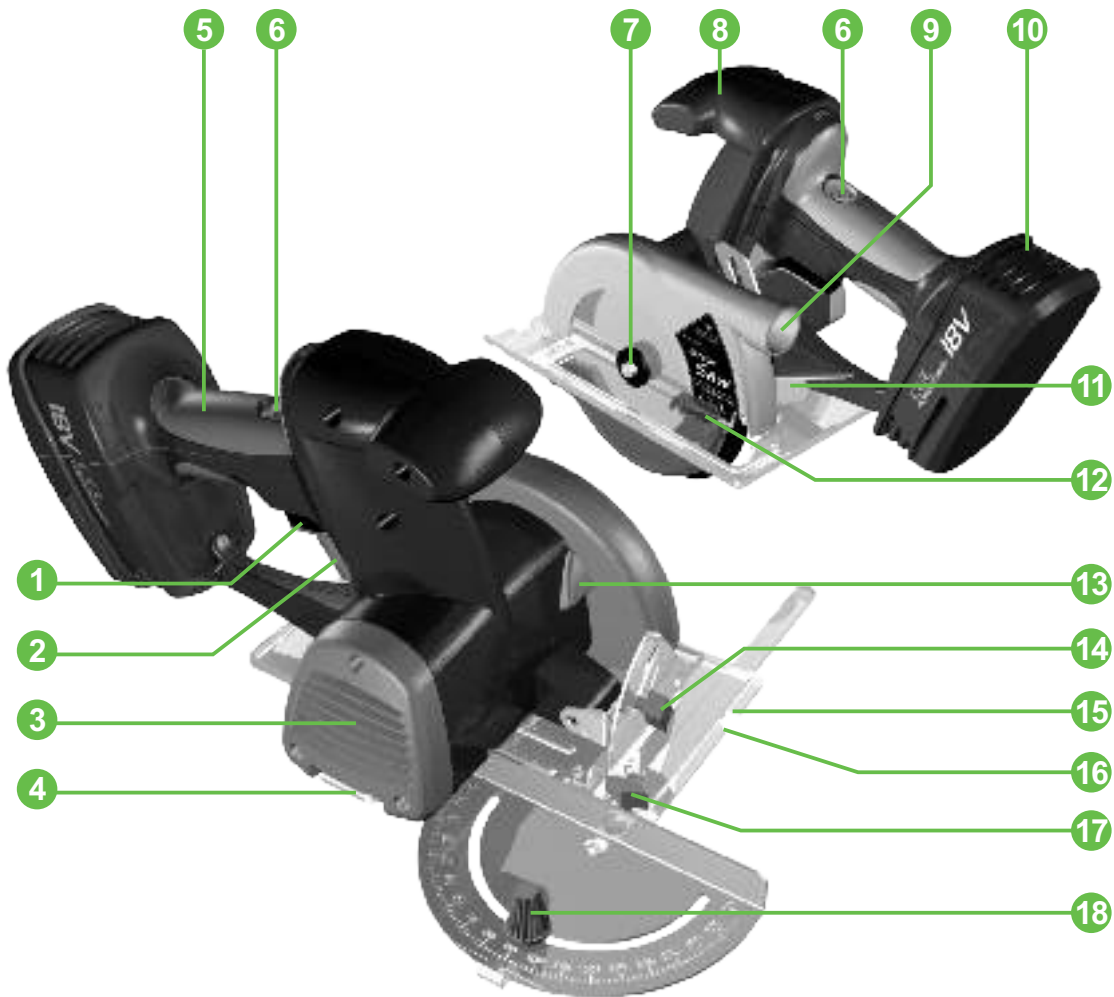

## Additional Safety Rules Circular Saws

- a) Keep hands away from cutting area and blade. Keep your second hand on the auxiliary handle, or motor housing. If both hands are holding the saw, they cannot be cut by the blade.
- b) Do not reach underneath the workpiece. The guard cannot protect you from the blade below the workpiece.
- c) Adjust the cutting depth to the thickness of the workpiece. Less than a full tooth of the blade teeth should be visible below the workpiece.
- d) Never hold the piece being cut in your hands or across your leg. Secure the workpiece to a stable platform. It is important to support the work properly to minimise body exposure, blade binding, or loss of control.
- e) Hold the power tool by the insulated grip when performing an operation where the cutting tool may contact hidden wiring or its own cord. Contact with a “live” wire will also make exposed metal parts of the power tool “live” and shock the operator.
- f) When ripping, always use a rip fence or straight edge guide. This improves the accuracy of cut and reduces the chance of the blade binding.
- g) Always use blades with correct size and shape (diamond versus round) or arbour holes. Blades that do not match the mounting hardware of the saw will run eccentrically, causing loss of control.

h) Never use damaged or incorrect blade washers or bolt. The blade washers and bolt were specifically designed for your saw, for optimum performance and safety of operation

l) Wear goggles, ear protection and breathing mask for better protection yourself against personal Injury.

### Causes and operator prevention of kickback

- Kickback is a sudden reaction to a pinched, bound or misaligned saw blade, causing an uncontrolled saw to lift up and out of the workpiece towards the operator.
- When the blade is pinched or bound tightly by the kerf closing down, the blade stalls and the motor reaction drives the unit rapidly back towards the operator.
- If the blade becomes twisted or misaligned in the cut, the teeth at the back edge of the blade can dig into the top surface of the wood causing the blade to climb out of the kerf and jump back towards operator.

Kickback is the result of tool misuse and/or incorrect operating procedures or conditions and can be avoided by taking proper precautions as given below.

a) Maintain a firm grip with both hands on the saw and position your arms to resist kickback forces. Position your body to either side of the blade, but not in line with the blade. Kickback could cause the saw to jump backwards – you will be able to control its force by standing on the side.

**b)** When the blade is binding, or when interrupting a cut for any reason, release the trigger and hold the saw motionless in the material until the blade comes to a complete stop. Never attempt to remove the saw from the work or pull the saw backward while the blade is in motion or kickback may occur. Check the situation and take corrective actions to eliminate the cause of blade binding.

**c)** When restarting a saw in the workpiece, centre the saw blade in the kerf and check that the saw teeth are not engaged into the material. If saw blade is binding, it may kick back from the workpiece as the saw is restarted.

**d)** Support large workpieces to minimize the risk of blade pinching and kickback. Large workpieces tend to sag under their own weight. Supports must be placed under the panel on both sides, near the line or cut and near the edge of the piece.

**e)** Do not use dull or damaged blades. Unsharpened or improperly set blades produce a narrow kerf causing excessive friction, blade binding and kickback.

**f)** Blade depth and bevel adjusting locking levers must be tight and secure before making a cut. If blade adjustment shifts while cutting, it may cause binding and kickback.

**g)** Use extra caution when making a “plunge cut” into existing walls or other blind areas. The protruding blade may cut objects that can cause kickback.

## Safety instructions regarding lower guard

**a)** Check lower guard for proper closing before each use. Do not operate the saw if the lower guard does not move freely and close instantly. Never clamp or tie the lower guard in the open position. If the saw is accidentally dropped, lower guard may be bent. Raise the lower guard with the blade guard lever and make sure it moves freely and does not touch the blade or any other part, in all angles and depths of cut.

**b)** Check the operation of the lower guard spring. If the guard and the spring are not operating properly, they must be serviced before use. Lower guard may operate sluggishly due to damaged parts, gummy deposits, or a build-up of debris.

**c)** Lower guard should be retracted manually only for special cuts such as “plunge cuts” and “compound cuts”. Raise lower guard by blade guard lever. As soon as blade enters the material, the lower guard must be released. For all other sawing tasks, the lower guard should operate automatically.

**d)** Always ensure that the lower guard is covering the blade before placing the saw down on bench or floor. An unprotected, coasting blade will cause the saw to move backward, cutting whatever is in its path. Be aware of the time it takes for the blade to stop after the switch is released.

**WARNING!** Always remove the battery pack (POWERhandle) from the tool before making any adjustments or maintenance, including changing the blade.

## **.Safety instructions regarding the saw**

- When operating the saw, use safety equipment including safety goggles, ear protection, dust mask and protective clothing including safety gloves.
- Do not use the saw to cut firewood.
- Ensure that the lighting is adequate in the work area.
- Do not let anyone under the age of 18 years operate the saw.
- Always stand to one side when operating the saw.
- Never use a cracked or distorted saw blade. Only use sharp blades.
- When cutting round wood, use clamps that prevent the workpiece from turning.
- Never use your hands to remove sawdust, chips or waste close to the blade.
- Only use recommended blades.
- Do not use High Speed Steel (HSS) blades with this saw.
- Rags, cloths and string should never be left around the work area.
- Avoid cutting nails. Inspect the work piece and remove all nails and other foreign objects before beginning the cut.
- Support the work properly.
- Never reach over the blade to remove waste or off-cuts.
- Do not attempt to free a jammed blade. before first switching off the tool.
- Do not slow or stop a blade with a piece of wood. Let the blade come to rest naturally.
- If you are interrupted when operating the saw, complete the process and switch off before looking up.
- Periodically check that all nuts, bolts and other fixings are properly tightened.
- Always hold the saw on parts that are insulated. If you accidentally cut into hidden wiring or the saw's own cable, the metal parts of the saw will become "live".
- Never use the saw near flammable liquids or gases.
- Note the direction of rotation of the motor and the blade.
- Do not lock the movable guard in the open position and always ensure that it is working properly, freely rotating and returning to fully cover the teeth of the blade.
- This circular saw is installed with a riving knife. The function of a riving knife is to prevent the work piece from closing onto the blades. It must be securely fitted clear of the blade.
- Always use the riving knife provided except when plunging in the middle of work piece or glove cut is required.



## Switching On and Off

This product, when combined with the POWERhandle, is fitted with a safety button (MPB).

1. To start the machine, press MPB. Then squeeze the trigger.
2. Release the safety button when the machine starts. The machine will now run continuously.
3. To stop the machine, release the on/off trigger.

**WARNING:** The tool runs for approximately 2 seconds after it has been switched off. Let the motor come to a complete standstill before setting the tool down.

## Adjusting the cutting depth

**WARNING:** Always ensure that the saw is switched off and the POWERhandle is detached from the tool before making any adjustments.

Refer to 6.1 “Know your product” about the location of trigger, buttons and locks. Ensure that the saw is facing away from you.

1. Loosen the depth adjustment lock by pulling the lever up.
2. Hold the base plate flat against the edge of the workpiece and lift the body of the saw until the blade is at the required depth.
3. The correct depth is set when the blade does not protrude more than  $\frac{1}{4}$ " (6.35mm) below the material being cut. Tighten the depth adjustment lock by pressing the lever down.

## Adjusting the Bevel Angle (Mitre Cut)

**WARNING:** Always ensure that the saw is switched off and the POWERhandle is detached from the tool before making any adjustments.

1. Refer to “6.1 Know your product” about the location of trigger, buttons and locks. Ensure that the saw is facing away from you.
2. Loosen the bevel angle locking knob located at the front of the base plate.
3. Tilt the body of the saw until the required angle is reached.
4. Use the quadrant scale as a guide.
5. Tighten the locking knob to secure the base plate.

**NOTE:** For accurate work it is necessary to make a trial cut, measure the work and reset the angle until the correct setting is achieved.

## Making a Cut

1. Mark the line of cut on the workpiece. Adjust the depth of cut and bevel angle as required.

**Note:** When making 90° cross or rip cuts, align your line of cut with the outer blade guide notch on the base of the saw.

**Note:** When making 45° bevel cuts, align your line of cut with the inner blade guide notch on the base of the saw.

2. Rest the front edge of the base on the workpiece.

3. Start the motor by depressing the MPB and squeezing the trigger switch.

**NOTE:** Always let the blade reach full speed (approximately 2 seconds) before you begin to cut into the workpiece.

4. Slowly push the saw forward using both hands.

**NOTE:** When making a cut always use steady, even pressure. Forcing the saw causes rough cuts and could shorten the life of the saw or cause kickback. Allow the blade and the saw to do the work.

5. After completing your cut, release the trigger switch and allow the blade to come to a complete stop.

**NOTE:** Do not remove the saw from the workpiece while the blade is moving.

**NOTE:** Since blade thickness varies, always make a trial cut in scrap wood along the guideline to determine how much, if any, the guideline must be offset to get an accurate cut.

## Using the Parallel Fence (Cross Cut or Rip Cut)

The parallel fence allows you to make parallel cuts in a sheet of wood at a set width.

**WARNING:** Always ensure that the saw is switched off and the POWERhandle is detached from the tool before making any adjustments.

1. Adjust the fence angle to 90° and tighten the Angle Lock knob (18).

2. Slide the fence (protractor) into the slot in the sole plate.

3. Adjust the guide to the require width and secure it to the position with the fence locking Knob (17).

4. Ensure that the guide rests against the wood along its entire length to give a consistent parallel cut.

## Making Pocket Cut

1. Set depth and bevel adjustment accordingly.

2. Tilt saw forward with cutting guide notch line up with the line drawn.

3. Raise the Lower Guard by using lower blade guard lever (12) and hold the saw.

4. With the blade clearing the material to be cut, start the motor.

5. Gradually lower the back end of the saw using the front end of the sole plate as the hinge point.

**WARNING:** As block starts cutting the material, release the lower guard immediately. When the sole plate rests flat on the surface being cut, proceed cutting in forward direction to end of cut.

## Changing the blade

**WARNING.** Always ensure that the saw is switched off and the POWERhandle is detached from the tool before making any adjustments.

1. Rotate the saw blade by hand while depressing the spindle lock button until the blade locks.
2. Turn the blade bolt clockwise using the hex key provided.
3. Remove the outer blade flange and the blade bolt.
4. Remove the saw blade from the inner flange and pull it out.

**NOTE:** Clean the saw blade flanges thoroughly before mounting the new saw blade.

5. Mount the new saw blade in reverse order and tighten the blade bolt.

**WARNING.** The direction in which the blade rotates has to be the same as the direction of the arrow marked on the housing.

Ensure that the spindle lock button is released.

Before using the saw again, check that the safety devices are in good working order.

**IMPORTANT.** After replacing the saw blade, make sure that the blade runs freely by turning it by hand.

Re-attach the POWERhandle and run the saw under no load to check that it runs smoothly before using it to cut any material.

## General Inspection

Regularly check that all the fixing screws are tight. They may vibrate loose over time.



***POWER8***  
***workshop***  
***7. Jigsaw***

## Specifications

---

Voltage:	18V
No load speed:	0-2400 RPM
<hr/>	
Max Cutting Capacity:	
Metal	¼" (13 mm)
Wood	2" (50 mm)
<hr/>	
Weight:	4.5lbs (2.1 kg)

---

## Know Your product

1. Handle release latch
2. Soft grip
3. Power trigger/Stop
4. MPB (Safety lock)
5. Motor cooling vents
6. Blade cover
7. Blade guide wheel
8. Hex screw
9. Blade
10. Sole plate
11. Hex key
12. Angle adjustment bolt

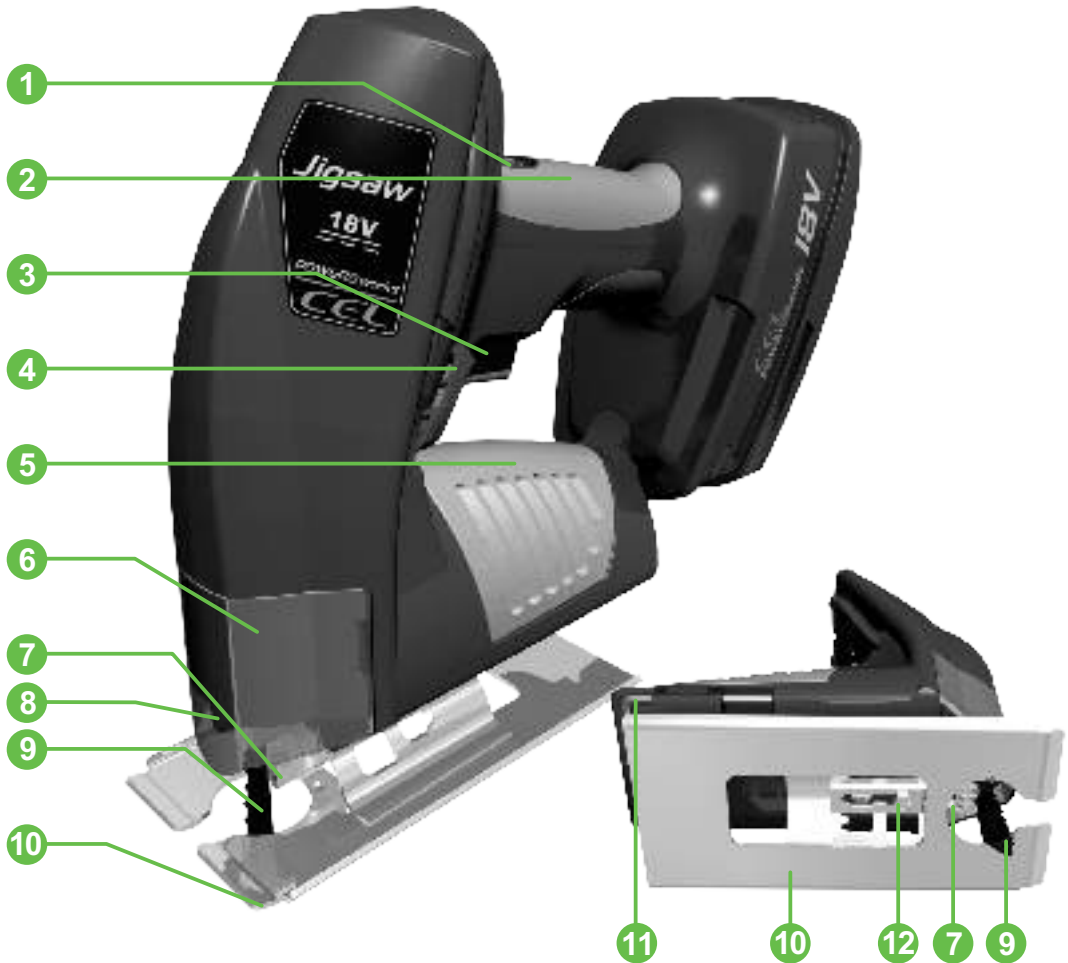

## Additional Safety Rules Cordless Jigsaws

- When operating the saw, use safety equipment including safety goggles, ear protection, dust mask and protective clothing including safety gloves.
- The jigsaw is fitted with an adjustable blade guide roller, ensure that this is correctly adjusted.
- Do not start the machine with the blade in contact with the workpiece.
- Check the workpiece for any protruding nails, screw heads or anything that could damage the blade.
- Ensure that there are no obstructions underneath the workpiece; it is easy to cut into sawhorses and bench tops.
- Hold the machine correctly and adopt a stable stance.
- Use the correct blade for the job and replace the blade as soon as it becomes worn. This will ensure ease of cutting and prolong the life of the machine.
- Always ensure that the base plate is in firm contact with the workpiece before starting the cut.
- Do not force the jigsaw, let the jigsaw do the work. Forcing the jigsaw will reduce the life of the blade putting undue pressure on the machine.
- Allow the jigsaw to stop completely before removing it from the workpiece.
- Do not try and cut a curve that is too tight. This will put undue pressure on the blade causing it to snap.
- Keep hands away from cutting area and blade.
- Do not reach the underneath the workpiece.
- Never use your hands to remove sawdust, chips or waste close by the blade.
- Support the work properly.
- Never reach over the blade to remove waste or off cuts.
- Do not attempt to free a jammed blade before first switching off the tool.
- If you are interrupted when operating the saw, complete the process and switch off before looking up.
- Always hold the saw on parts that are insulated. If you accidentally cut into hidden wiring or the saw's own cable, the metal parts of the saw will become "live".
- Never use the saw near flammable liquids or gases.
- The blade roller guide is used to support the blade when cutting and must be in contact with the back edge of the cutting blade at all times and allowed to move freely.



## Switching the Jigsaw On and Off

**NOTE:** This product when combined with the POWERhandle is fitted with a safety button (MPB).

1. To start the machine, press MPB. Then squeeze the trigger.
2. Release the safety button when the machine starts. The machine will now run continuously.
3. To stop the machine, release the on/off trigger.

## Making a Cut

1. Start the motor by depressing the MPB and squeezing the trigger switch .
2. Slowly push the saw forward.
3. After completing your cut, release the trigger switch and allow the blade to come to a complete stop.

**NOTE:** If the jigsaw base is not held firmly onto the workpiece, the blade will snag and break.

## Angle Cutting

**CAUTION.** Always ensure that the saw is switched off and the POWERhandle is removed before any adjustments.

Loosen the hexagonal screw on the underside of the machine using the included hexagonal key and tilt the base, using a protractor to achieve the required angle 0°- 45°. Finally re-tighten the hexagonal screw.

## Blade Roller Guide

When setting the jigsaw for angle cutting or replacing the blade, set the blade roller guide. Loosen the hexagonal screw on the underside of the machine using the included hexagonal key. With the blade fitted, slide the blade roller guide mounting plate until the blade is in the groove in the blade roller guide and the guide is in contact with the back edge of the blade.

## Metal Cutting

When cutting metals, a suitable cooling/cutting oil must be used. Simply squirt the lubricant onto the blade or workpiece at regular intervals during cutting to reduce blade wear.

**WARNING:** Do not immerse the jigsaw in water or allow oil to enter the casing. A fatal electric shock could occur.

## Circle Cutting

When starting a cut from the center of the workpiece, drill a 12 mm diameter hole to ensure that there is enough clearance for the blade.

## Tip

When cutting materials with a decorative or polished finish, cover either the base of the jigsaw or the surface of the material being cut with masking tape or other suitable tape to prevent scratching.

## Changing the blade

**WARNING.** Always ensure that the saw is switched off and the POWERhandle is detached from the tool before making any adjustments.

1. To fit the blade, loosen the 2 hexagonal screws on the blade clamping block.
2. Slide the blade into the locating groove with the teeth pointing forward.
3. Tighten the hexagonal screws with the included hexagonal key.

**WARNING.** The teeth of the jigsaw blade should be pointing forward away from the user.

**IMPORTANT.** After replacing the saw blade, make sure that the hexagonal screws are firmly tightened and the blade is running freely.

Re-attach the POWERhandle and run the saw under no load to check that it runs smoothly before using it to cut any material.

## General Inspection

Regularly check that all the fixing screws are tight. They may vibrate loose over time.

***POWER8***  
***workshop***  
***8. Halogen Light***

# Halogen Light - Specifications and Know Your Product 8.1

## Specifications

Voltage:	18V
Bulb:	2 x 18v 0.6A Halogen
Bulb Life:	300 hours
Weight:	2.9lbs (1.3 kg)

## Know Your Product

1. Lens
2. Lens bezel
3. Torch arm
4. Torch body
5. Air cooling vent
6. MPB (Multi-Purpose-Button)
7. Handle trigger (Flash Light)

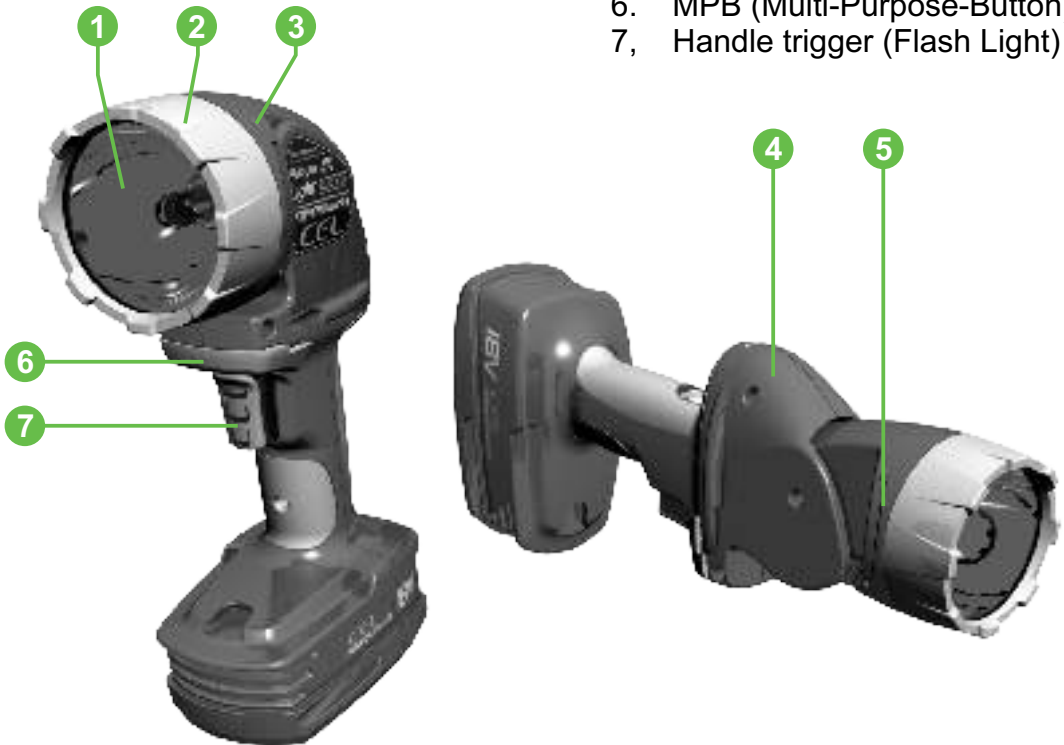

## **Switching the Halogen Light on and off**

**NOTE:** This product when combined with the POWERhandle is fitted with Multi-Purpose Button (MPB).

1. To turn the halogen light on, slide the MPB button to the right.
2. To turn the halogen light off, slide the MPB button to the left.

## **Flash Light**

1. To flash the light, slide the MPB button to right. Then press and release the handle trigger.

## **Rotate the halogen light head**

1. To swivel the head of the halogen light, hold the body firmly with one hand.
2. Move the head of the halogen light up and down as required with the other hand.

## Replacing the Light Bulb

**WARNING.** The halogen light immediately begins to heat up when it is being used. Please handle the halogen light with care especially around the light bulb and lens. Extra caution should be taken when replacing the light bulb. Allow the light to cool down before attempting to change the light bulb.

To change the light bulb, hold the top of the light with one hand and the rim of the halogen light lens with the other. Start turning the rim of the lens in a counter clockwise direction.

Continue to turn the rim until it separates from the body of the halogen light. Handle with care when doing this to avoid damaging the reflector or the protective lens.

The burnt out bulb should be removed from the spring and discarded appropriately.

This halogen light is shipped with a spare light bulb. It is stored inside the light assembly. You can see it when you remove the rim and light assembly. Replace the new bulb in the spring.

Carefully align the rim and light assembly with the halogen light body. Twist the lens rim in a clockwise direction to reattach the lens cover.

## Cleaning

1. Clean the halogen light regularly. Before cleaning, remove the battery pack and any accessories. To clean use **ONLY** a mild soap and damp cloth on the housing. Never immerse the halogen light in water or any kind of liquid.
2. Remove dust and dirt regularly. Cleaning is best done with compressed air or a rag.
3. Do not open the halogen light (other than to change the light bulb as described above)

## General Inspection

Regularly check that all the fixing screws are tight. They may vibrate loose over time.

**CAUTION.** Do not use cleaning agents to clean the plastic parts of the halogen light. A mild detergent on a damp cloth is recommended. Water must never come into contact with the halogen light.

***POWER8***  
***workshop***  
***9. Case***

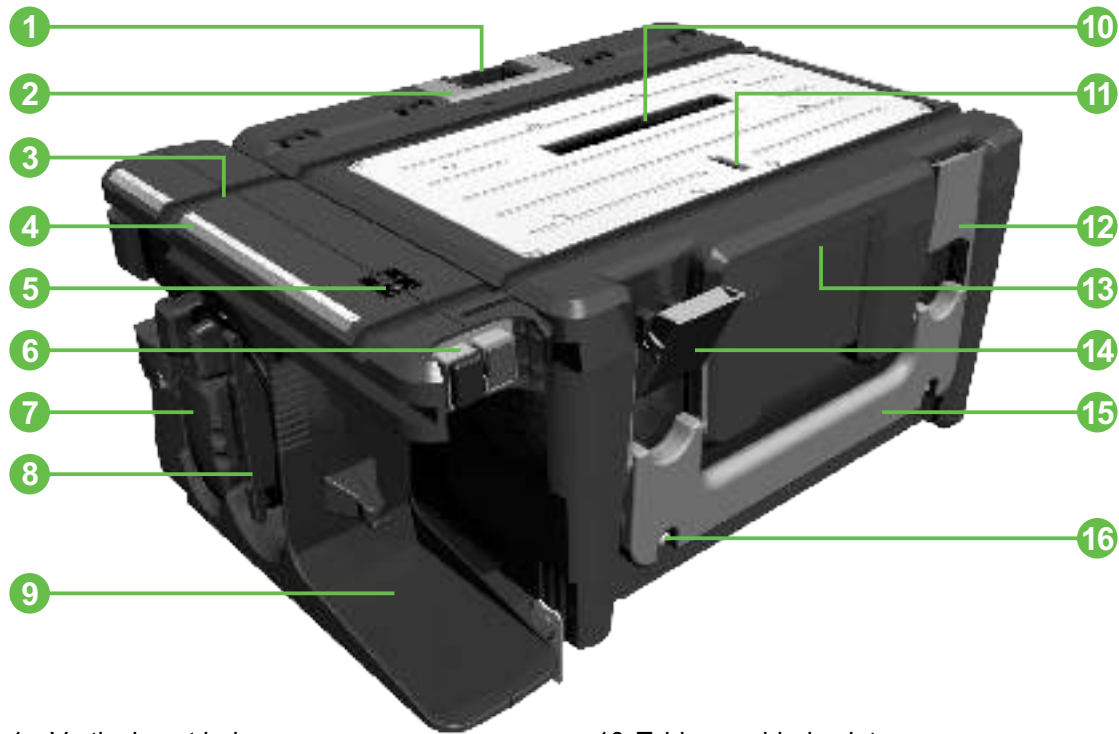

1. Vertical post hole
2. Vertical post release lever
3. Angle fence running slot
4. Parallel fence measurement guide
5. Battery power and charger indicators
6. Benchtop On/Off operation buttons
7. Secondary charger point(SCP)
8. Cable storage hooks
9. POWERhandle charger dock

10. Table saw blade slot
11. Scroll saw blade slot
12. Case latch (closed)
13. Case opening handle
14. Case latch (open)
15. Case carry handle
16. Case carry shoulder strap fixing



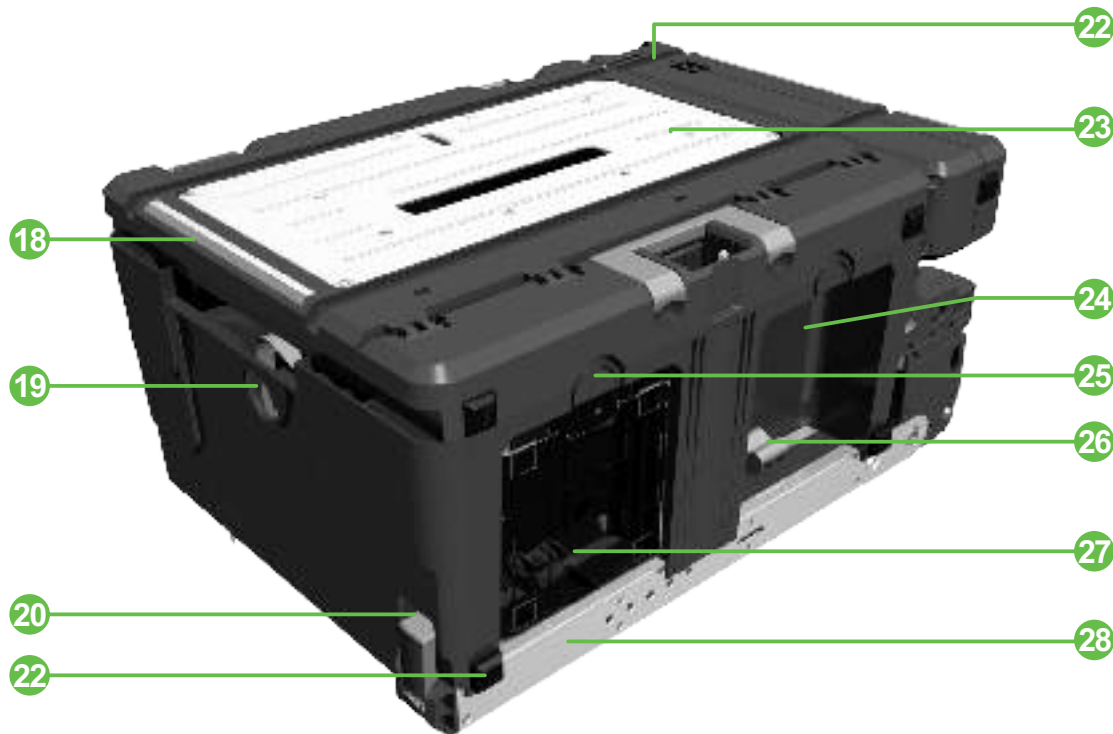

- 18. Parallel fence measurement guide
- 19. Future product mount
- 20. Post storage pocket
- 21. Rubber feet
- 22. Angle fence running slot
- 23. Steel armoured work surface
- 24. Accessory box storage area
- 25. Accessory box release button

- 26. Accessory box location hook
- 27. *Optional Accessory box*



1. Product case lock
2. Internal power coupling
3. Circular saw sole plate pocket
4. Jigsaw sole plate pocket
5. Internal power coupling cable storage
6. Work surface clamp
7. Post handle
8. Protractor
9. Jigsaw blades
10. Screw to fix case to work surface
11. User manual

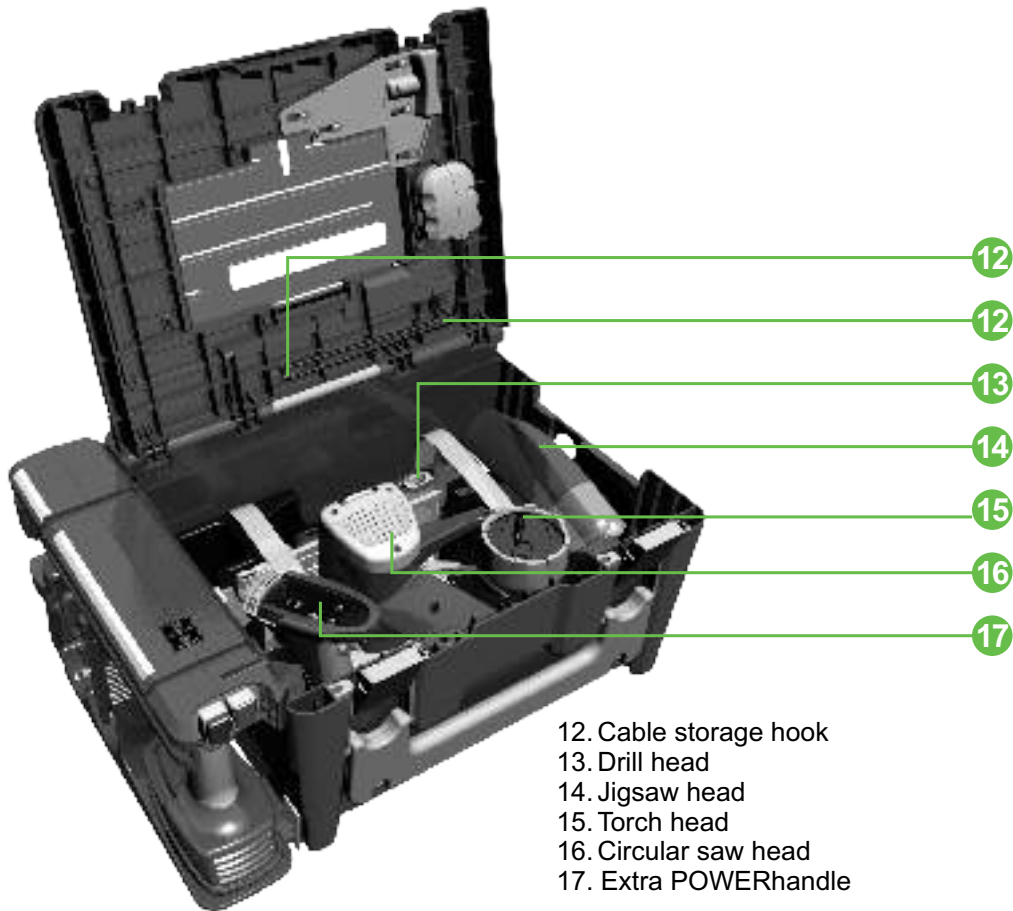

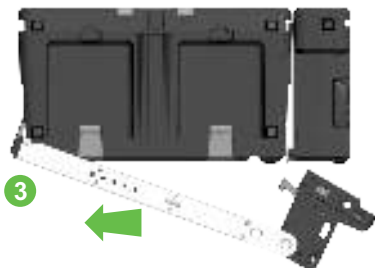
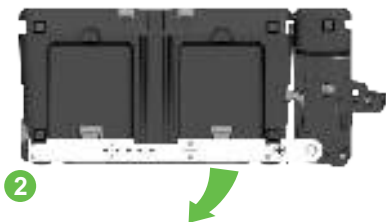
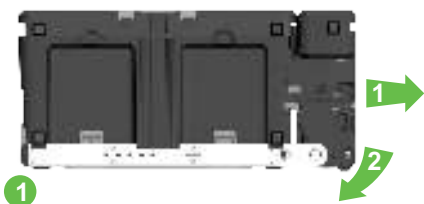

## Accessory Case Release



## Post Removal

To remove the post from its storage area, first close the case lid and ensure that the latches are both locked. Place the case onto its front face (handle area) the post should be facing you.

1. Grip the moving part of the post head and pull it away from the case. This will release the latch and allow the head of the post to rotate out.

Note: May use the post handle to slide the post head away from the case easily.

2. When the latch is clear of the recess rotate out the metal portion of the post to approx 20°.
3. Now slide the post along the bottom of the case to allow the other post hook to come free from the POWER8works.

## Post Replacement

To replace the post, once again place the case onto its front face.

Hook the green post hook into the post storage pocket.

Rotate the post head and push the active post hook until the latch "clicks" into recess inside the case.

## Accessory Case Release

4. Press the latch on the back of the case (with the arrow pointing up) upward, then pull the accessory case by thumb away from the case to release it.

***POWER8***  
***workshop***  
***10. Table Saw***

## Specifications

Voltage:	18V
No load speed:	3,500 RPM
Cutting depth @ 0°:	(20mm) ~ (38mm)
Cutting depth @ 45°:	(14mm) ~ (27mm)
Blade diameter:	5½" (140mm), 24 tooth TCT
Blade bore:	3⁄8" (10mm)
Blade kerf:	1¹⁄₁₆" (18mm)

## Know Your Product

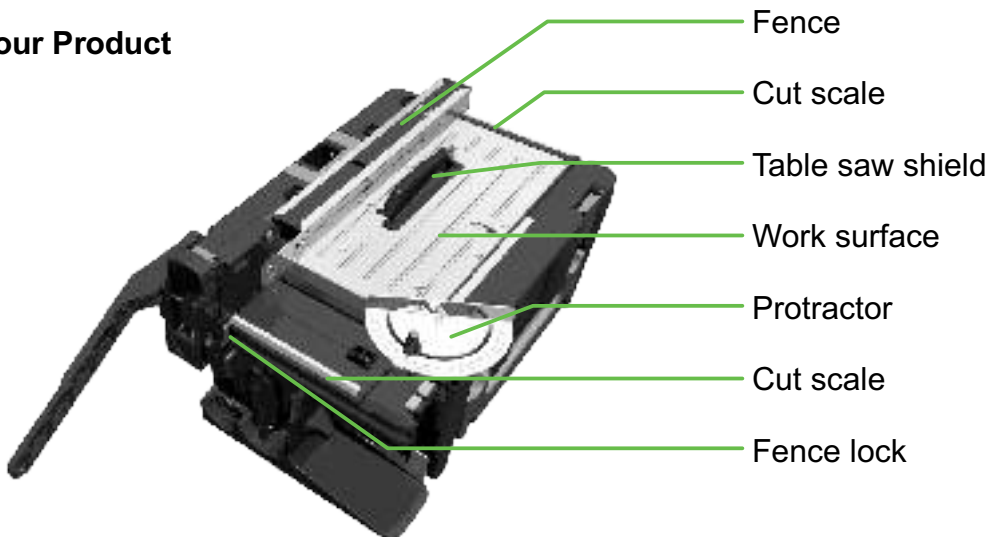

Please also refer to 2.1 - General Safety Instructions and 6.2 - Additional Safety Rules - Circular Saw before using the table saw.

Do not install the post and/or drill to the bench for drill Press function while using the table saw.

Keep guards in place and in working order. Never operate the tool with any guard or cover removed. Make sure all guards are operating properly before each use. Never start table saw when any rotating components are in contact with workpiece.

Always use a fence or straight edge guide when ripping.

Always use a push stick for ripping narrow stock. A push stick is a device used to push a work piece through the blade instead of using your hands. Size and sharp can vary but the push stick must always be narrower than the workpiece to prevent the push stick from contacting the saw blade.

Support large panels to minimize risk of the blade pinching and kickback.

Provide adequate support to the rear and sides of the saw table for wide or long workpiece. Use only correct blades, do not use blades with incorrect size holes. Never use blade washers or bolts that are defective or incorrect. The maximum blade capacity of your saw is 140mm.

Avoid cutting nails. Inspect for and remove all nails from lumber of workpiece before cutting.

Never touch blade or any moving parts during use.

Keep hands away from cutting area. Keep hands away from blades. Do not reach underneath work or around or over the blade while it is rotating.

Do not attempt to remove cut material when blade is moving.

Never attempt to free a stalled saw blade without first turning the saw OFF.

Guard against kickback. Kickback occurs when the blade stalls rapidly and workpiece is driven back resulting in serious personal injury. Stay out of blade path and turn switch off immediately if blade binds or stalls.

Never leave the table saw running unattended. Turn power OFF by pressing the RED Button. Don't leave tool until it comes to a complete stop.

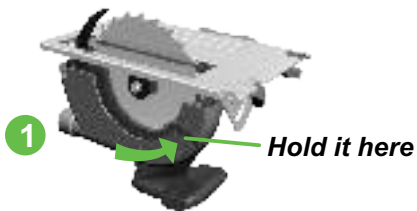

### How to mount the TABLE SAW GUARD:

**Warning:** Remove the battery handle from the Circular Saw before assembling the TABLE SAW GUARD.

If the TABLE SAW GUARD has not been installed, then follow instructions below:

1. Turn the Circular saw head upside down as (1). Retract the circular saw shield all the way and hold it out of the way by using the lever on the side of the product.

2. Align the protrusion on the metal support of TABLE SAW GUARD and insert it to the hole on the sole plate of the Circular saw. Then rotate the rear end of TABLE SAW GUARD down over the riving blade as fig.2.

3. Press the rear end of TABLE SAW GUARD down until the latch hooks up with the sole plate. When it fits flat with the sole plate of the circular saw, this should now hold the Circular saw shield out of the way.

4. The Circular saw is now ready to be installed into the case.

**Warning:** Never operate the tool with any guard or cover removed. Make sure all guards are operating properly before each use.

**NOTE.** TABLE SAW GUARD is correctly mounted as per fig 4 (mounted on when packed away)

**NOTE.** The Table Saw will NOT operate if the TABLE SAW GUARD is not correctly mounted.

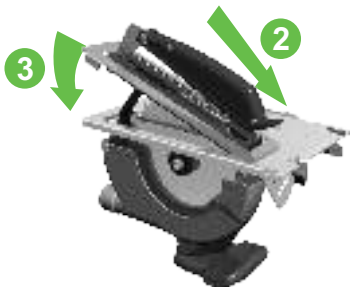



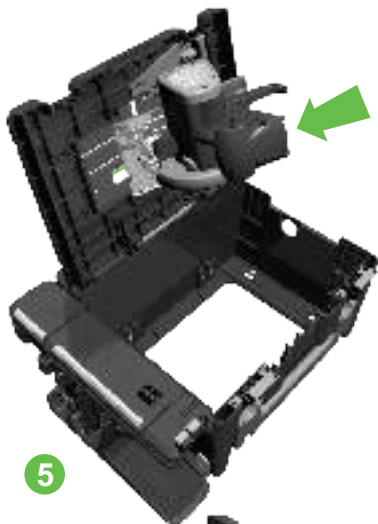

5. Open the case and push the front of the sole plate into the pocket on the underside of the case lid.

6. Pull back the green product lock slider and rotate the rear of the circular saw into the case lid until the sole plate is against the metal work surface, release the product lock, check that it returns fully left. If it doesn't then the circular saw can't be fully pushed in.

7. Remove the internal power coupling from its storage pocket and slide it onto the top of the circular saw until it will not go any further.

**Warning:** Never operate the tool with any guard or cover removed. Make sure all guards are operating properly before each use.

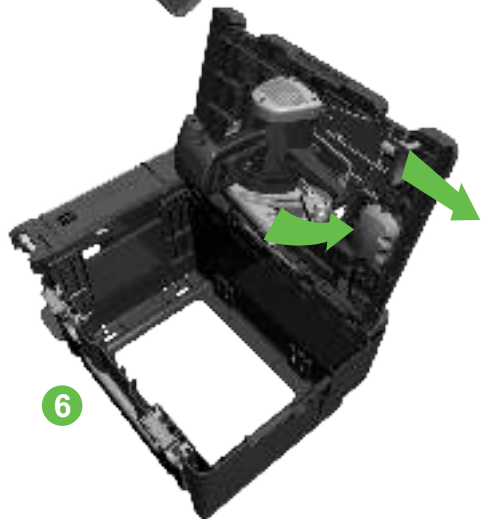

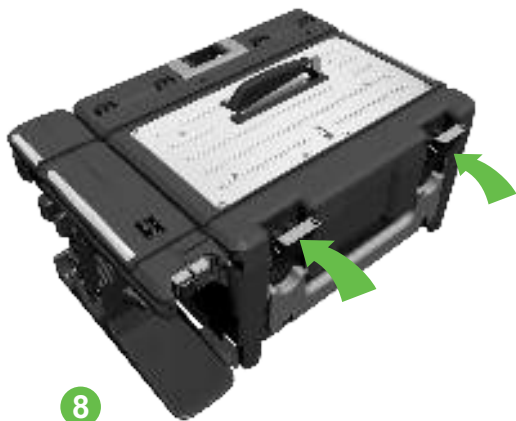

8

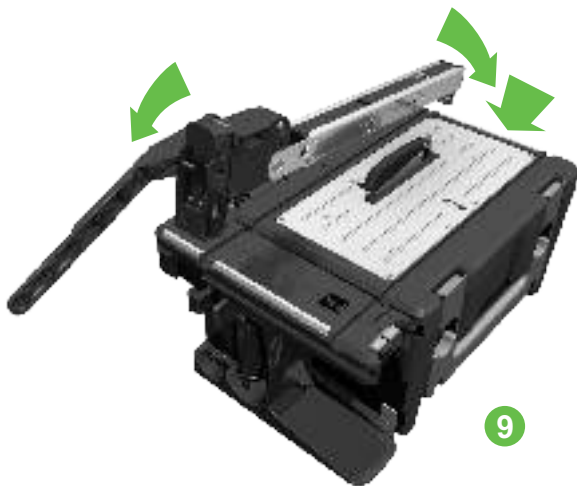

9

8. Close the lid of the case and ensure that both latched are closed.

**WARNING** the Table Saw will not work unless the lid is closed.

TO INSTALL THE FENCE:

If required the POST can be used as a parallel fence. The post can be assembled on to the case on both side of the saw blade.

9. To install the fence, use the green hook, on the bottom of the post, to latch under the case lid, pull the fence tight towards the centre of the case. Then lower the locking end until the fence lies parallel with the table surface. Swing the head of the fence down and press it down until it hooks into the groove on the charger dock.

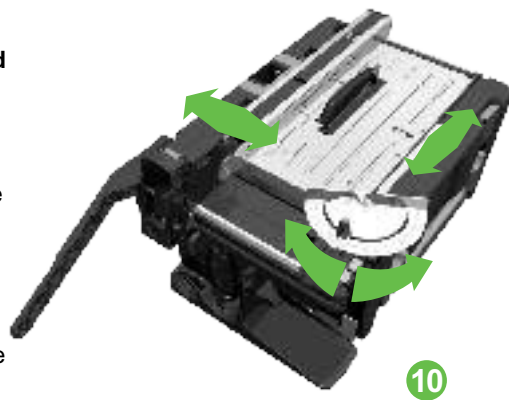

10

On both edges of the case lid there are dimension to give a guide to the cut width. When fitting the post it is important to ensure that both ends of the post are the same distance from the blade (*parallel to the blade*), use the dimension to check this.

Lifting the head of the Post will again release the fence and allow it to be remove and the position to be changed.

10. The depth and angle of the blade can be adjusted by simply lifting the lid and using the Adjustment knobs, the same as described in the "Circular Saw Use" section of this user manual. The angle plate can be used as a angle fence, by placing it in one of the groves on the case work surface.

11. Insert the POWERhandle into the handle dock, your table saw is now ready to use.

**NOTE:** When the table saw is configured in the way you require it is time to add a POWERhandle into the charger dock, this will supply power to the case and you can start cutting your work.

**NOTE:** Table saw is started and stopped by the main case operation button above the charger dock. The table saw will not work unless the Table Saw Guard is correctly installed and the case lid is shut. If the Case is connected to the main then the POWER8handle will be charged when the table saw in not in operation.

## Different Type of Cutting

The Power8 Table Saw can be used for different wood cutting operations ,as straight-line cutting operations such as cross cutting, parallel cutting, angle cutting, bevel cutting, and compound cutting.

1. Cross cuts are straight 90' cuts made across the grain of the workpiece. The wood is fed into the cut at a 9' angle to the blade, and the blade is vertical.
2. Parallel cuts are made with the grain of the wood. To avoid kickback while making a parallel cut, make sure oe side of the wood rides firmly against the fence.
3. Mitre cuts are made with the wood at any angle to the blade other than 90'. The blade is vertical.
4. Bevel cuts are made with an angled blade. Bevel cross cuts are across the wood grain, and bevel rip cuts are with the grain. The rip fence must alwways be on the left side of the blade for bevel rip cuts.
5. Compunds (or bevel) mitre cuts are made with an angled blade on wood that is angled to the blade.

## Switching Table Saw On and Off

1. To start the saw, press the green operation button above the charger dock.
2. The machine will now run continuously.
3. To stop the machine, press the red operation button above the charger dock.

**NOTE:** When the table saw is configured in the way you require it is time to add a POWERhandle into the charger dock, this will supply power to the case.

**NOTE:** The table saw will not work unless the table saw shield is correctly installed and the case lid is shut. If the case is connected to the main then the POWERhandle will be charged when the table saw is not in operation.

## Making a Cut

1. Setup the table saw to the your cutting requirement with the use of the additional or optional accessory provided (Parallel Fence, Protractor or Push Stick).
2. Switch on the machine by pressing the green operation button above the charger dock.
3. Hold the workpiece firmly with both hands and feed into the saw blade slowly. For narrow work which has the fence set closely to the blade use the push stick end of the post lever to hold the work down next to the blade.

4. When the cut is made, turn the saw off by press the red button.

5. Wait for the blade to come to a complete stop before removing the workpiece.

## Adjusting the Table Saw

**CAUTION.** Always ensure that the table saw is switched off and the POWERhandle is removed before any adjustments are made.

1. To adjust the blade depth, open the lid, and release the depth adjustment lock then lower the circular saw to expose the correct amount of blade, then relock the adjustment lever.

---

Cutting depth @ 0°:  $\frac{3}{4}$ "(20mm) ~ 1 $\frac{1}{2}$ "(38mm)

---

Cutting depth @ 45°:  $\frac{1}{2}$ "(14mm) ~ 1 "(27mm)

---

**NOTE:** To give better cutting performance, the blade depth should be set so that the upper points of the blade is higher than the workpiece by approximately 3mm (1/8 in) to 6mm (1/4 in).

2. To adjust the blade angle, open the lid, adjust the bevel angle lock knob on the circular saw to the desired cutting angle.

3. To adjust the width of a cut when using the fence loosen the fence by raising the post head slider up. release the green hook and reattach it at your desired width. Push down the post slider head down to tighten the fence onto the table

## Table Saw Different Cut Types

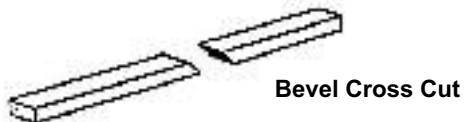
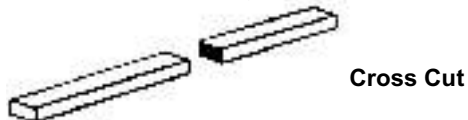

### Cross Cut

1. Remove the fence
2. Adjust the protractor angle to 90°.
3. Put the protractor into the groove at the front of the saw table.
4. Hold the workpiece and protractor firmly together and feed the workpiece slowly into the saw blade.



**Cross Cut**

### Miter Cut

1. Remove the fence
2. Adjust the protractor to the desired angle for you cut into the workpiece.
3. Put the protractor into the groove at the front of the saw table.
4. Hold the workpiece and protractor firmly together and feed slowly the workpiece into the saw blade



**Miter Cut**

### Rip Cut

1. Position the fence the desired distance from the blade for the cut. Securely lock the fence on the table by press the post slider head down firmly.
3. Hold the workpiece and protractor firmly together and feed them slowly into the saw blade.
4. Use the provided push stick or a push block to move the workpiece through the cut and past the blade.

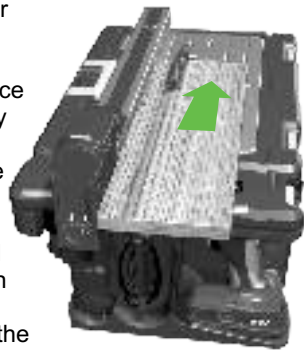

**Rip Cut**

## Bevel Cut

1. Open the lid of the saw table, adjust the circular saw bevel angle by releasing the lock knob and re-tightening at the desired angle.
2. Position the fence at the desired distance from the blade.
3. Use the provided push stick or a push block to move the workpiece through the cut and past the blade.

**WARNING:** Never push a small piece of wood into the blade with your hand, always use the provided push stick or a push block.



Bevel Cut

## Table Saw-Maintenance 10.5

### Store the Table Saw Properly

**WARNING.** Always ensure that the saw is switched off and the POWERhandle is detached from the tool before disassemble the product from the case.

1. Open Case lid, slide the internal plug away from the Jigsaw.
  2. Put internal plug back to its storage area.
  3. Slide back the product lock, and remove the Circular Saw Head from the bottom of the lid.
  4. Replace the tools to the Lift Out Tray before putting them back into the Case for storage.
- NOTE:** The Lift Out Tray is for easy storage and protection of tools inside the Case.
5. Disconnect the product from the mains power.

### General Inspection

Regularly check that all the fixing screws are tight. They may vibrate loose over time.

***POWER8***  
***workshop***  
***II. Drill Press***

## Specifications

Voltage: 18V

No load speed: 350 RPM, 1,250 RPM

Max Drilling Capacity:

Steel 1/2" (13 mm)

Wood 1 1/10" (28 mm)

Concrete 1/2" (13 mm)

Hammer Impact Frequency:

0-5,600, 0-20,000 min<sup>-1</sup>

Drill chuck capacity:

Single Sleeve 1/2" (13 mm) keyless

Double Sleeve " (10 mm) keyless

## Know Your product

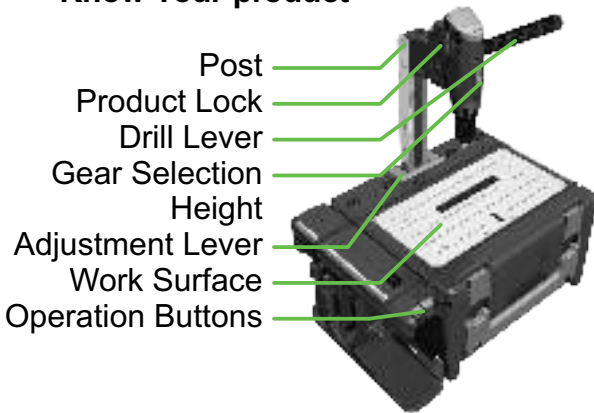

## Drill Press - Additional Safety Rules

## 11.2

Please also refer to 2.1 - General Safety Instructions and 5.2 - Additional Safety Rules - Cordless Drill/Driver before using the Drill Press.

Ensure the circular saw or jigsaw are NOT installed onto the lid of the case before starting to assemble the drill press.

Always use the lever provided to operate the drill press pull down function.

Use the work clamp provided to hold the workpiece firmly onto the table surface before starting cutting. Support workpiece on the table by thin wood before drilling.  
Use only correct drill bits and/or accessories.

The maximum chuck capacity of your this Drill Press is 10mm. *(13mm if you have purchased the Hammer action drill version)*

Never touch drill bit or any moving parts during use.

Do not attempt to remove workpiece or any other material when the chuck or cutting tool is moving.

Never leave the drill press running unattended. Turn power OFF by pressing the RED Button and remove the POWERhandle from the dock. Don't leave the drill press until it comes to a complete stop.



1. Remove the Post from its storage area, as described in 'Case Post Storage' section 9. It is not necessary to remove the lift out tool tray for the drill press function, but when the drill press is fully assembled it will become difficult to access the inside of the case. Now push the post firmly down into the hole on the top of the case with the green hook facing outward and the head over the centre of the work surface.

2. The post will snap into its highest setting whilst the green lever is flush with the work surface. The Green lever can be lifted from the rear at any time, this to allow the post's to move freely so the height can be adjusted. Move the post roughly to your required height and return the green lever flush with the work surface. You may need to slide the post up or down a little to find the next locking position.

3. Slide the drill up firmly up into the posts mating faces, until you hear a 'click'. Push down on the top of the drill to ensure it has latched in correctly. The release latches should be forward.

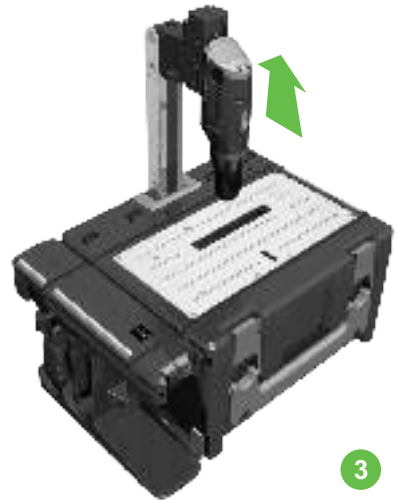
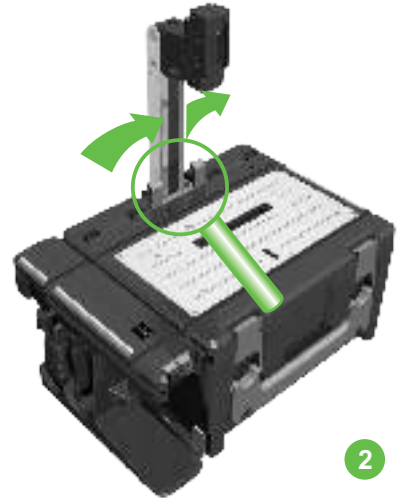
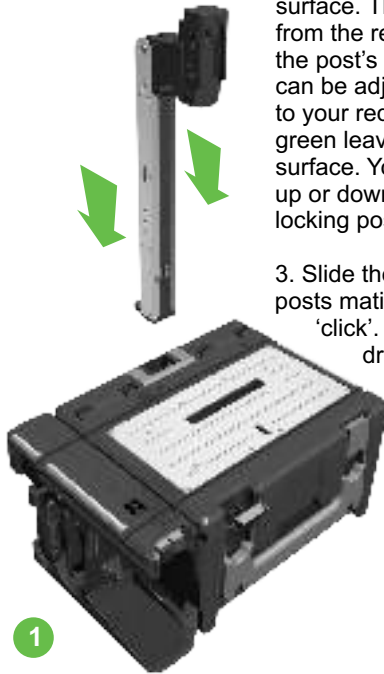



4. Add your required cutting tool to the drills chuck and tighten firmly. If further height adjustment is required please refer to stage 3.

5. The post lever can be fitted to either side to allow for left or right handed use. slide the front pin to the moving part of the post and the other pin into the elongated hole on the stationary part of the post. The drill should move down when the handle is pulled downwards now.

Use the post handle to pull down the drill press and make sure the drill bit will not touch the work surface when it is fully pulled down; at this point you may need to adjust the height again.

6. When the drill press is configured as you require assemble a POWERhandle into the charger dock to enable the product.

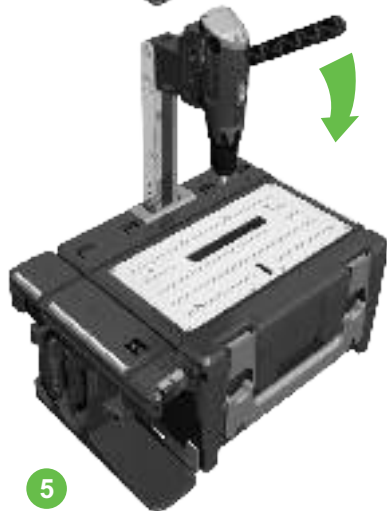

7. If using a drill with a tip 10mm or less then it is possible to use the table clamp to hold your work. Unwind the clamp knob until the open jaws can fit over the post and into the holes. Align the clamp pins into a pair of holes on the post and tighten the knob again. Place your work piece on the work surface in the correct position and further tighten the clamp until your work is firmly held in position.

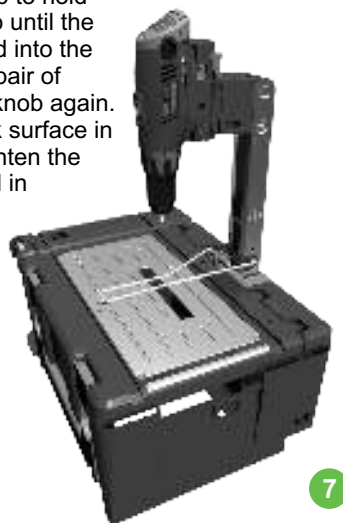

## Switching Drill Press On and Off

**NOTE:** Ensure that all body parts are clear of the cutting tool before installing a POWERhandle.

1. To start the machine, press the green operation button on the main case.
2. The machine will now run continuously.
3. To stop the machine, press the Red operation Button on the main case.

## Drilling a Hole

Fit a cutting tool such as a drill bit into the chuck as described in point 4.

Adjusting the height of the drill press by lifting the latches which lock the post in place and slide the post into the correct location, ensure the latch is flush with the work surface again before proceeding.

Select a suitable gear for your cutting tool and material. Low gear for large drill bits and cutting metal and high gear for small drills and softer materials.

**NOTE:** Drill a test hole in scrap wood before cutting your work.

**NOTE:** Put scrap material under the work piece you are cutting to stop damage to the work surface.

**Warning.** Never start the drill press with the

cutting tool on the work piece.

**NOTE:** Make sure the jigsaw and circular saw are NOT installed onto the case lid and the internal plug is NOT connected to a product. The drill press will not work if the jigsaw or circular saw are installed or the case lid is shut and latched.

The drill press is started and stopped by the main case operation ON/OFF button above the charger dock.

Start the drill, pull the post lever downwards slowly, align your marking with the cutting tool tip and continue to pull the drill slowly through your work piece. Let the drill do the work; don't force it through or your work will snag.

Return the lever to its upper position, then stop the Drill. At all times you must ensure your work piece is held firmly against the work surface.

**CAUTION.** Always ensure that the Table Saw is switched off and the POWERhandle is removed before any adjustments.

## Store the Drill Pres Properly

**WARNING.** Always ensure that the drill press is switched off and the POWERhandle is removed from the charger dock before disassembling the product.

1. Remove the post lever from side of the post.
2. Release the chuck and remove ant cutting tool.
3. Pull the green product lock backward and with the other hand slide the drill head down and out of the posts mating faces.
4. Lift the green post Release Lever up to release the post from the case.
5. Slide the post out from the case hole.
6. Open the lid of the case, replace the tools into the lift out tray and putting them back into the case for storage.

**NOTE:** *The Lift Out Tray is for easy storage and protection of tools inside the Case.*

7. Return the post into its storage area on the back of the case.
8. Disconnect the product from the mains power and return the SCP to its storage area.

## General Inspection

Regularly check that all the fixing screws are tight, they may vibrate loose over time. Ensure that all vents are clear of dust, swarf and debus.

***POWER8***  
***workshop***  
***12. Scroll Saw***

## Specifications

Voltage: 18V

No load speed: 2400 RPM

Max Cutting Capacity:

Metal (10 mm)

Wood (40 mm)

## Scroll Saw



## Scroll Saw - Additional Safety Rules

1. Please also refer to 2.1 - General Safety Instructions and 7.2 - Additional Safety Rules - Jigsaw before using this Scroll Saw.

2. This Scroll Saw (model number WS1-TS01) is only for light duty trimming and cutting. It is not intended for heavy or industrial use.

Always wear safety glasses with side shields, and gloves.

Do not install the drill into the post for drill press function while set up for Scroll Saw function.

Use the work clamp provided to assist you to gently hold the workpiece on the table while cutting.

Use only the correct jigsaw blade for materials to be cut, refer to 7.3 - Jig Saw Operating

Instructions when necessary. The maximum blade capacity of this Scroll Saw is 90mm, and maximum cutting for wood is 40mm.

Never leave the Scroll Saw running unattended. Turn power OFF by pressing the RED Button and remove the POWERhandle. Don't leave tool until it comes to a complete stop.

Provide adequate support to the rear and sides of the saw table for wide or long workpiece.

Keep hands away from cutting area and blade. Do not reach around or over the blade while blade is reciprocating.

Do not attempt to remove off cuts of material when blade is moving. Never attempt to free a stalled saw blade without first turning the saw OFF.

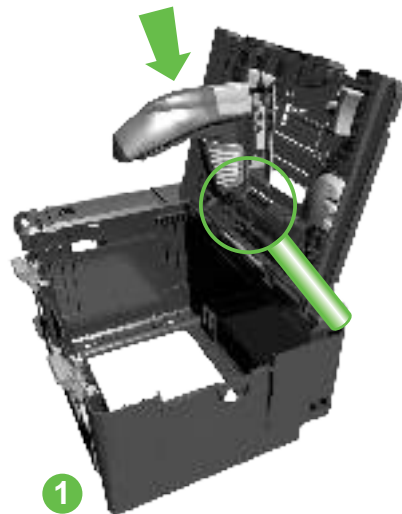

1. Open Case lid and remove all the tools and the carry tray. Take the jigsaw in your left hand and push the rear of the sole plate into the pocket on the bottom of the Case Lid.

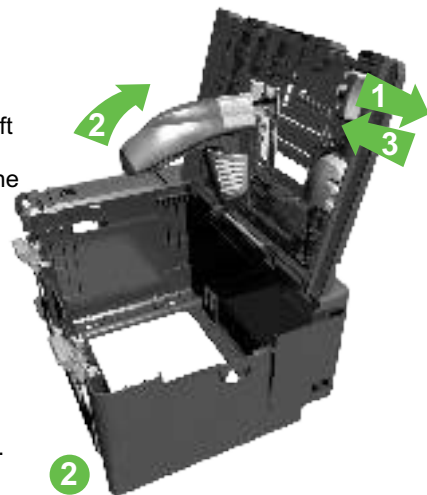

2. Slide back the product lock, and rotate the front of the jigsaw into position. When the sole of the jigsaw is fully in contact with the metal work surface release the product lock. Ensure that the product lock is fully returned to the left.

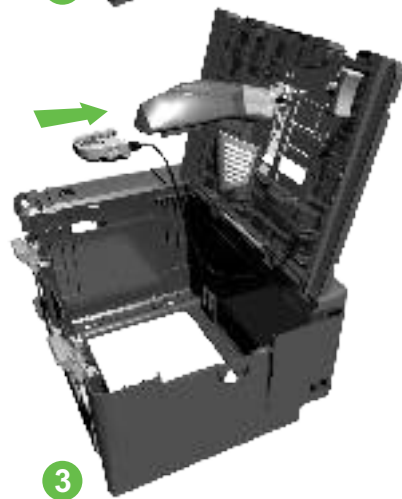

3. Remove the internal plug from its storage area, ensuring that the cable is free from its hooks.



4. Slide the internal plug onto the Jigsaw. Ensure that it is fully pressed into position.

5. Close the lid. Snap shut both the case latches

6. The table clamp can be fitted to press the work piece against the work surface. First install the post into the vertical position at the highest level. Rotate the adjustment knob until the open jaws can be passed over the post. Align the bar ends to fit onto the holes on the post and re-tighten to secure in place. The tighter the adjustment to the clamp knob the more pressure is applied to hold down your work.

7. Only after full installations and adjustments have been made should the POWERhandle be fitted into the charger dock to enable the product.

8. The Scroll saw is started and stopped by the main case operation ON/OFF button above the charger dock.



5



6



7



## Making Cuts

**CAUTION.** Always ensure that the scroll saw is switched off and the POWERhandle is removed before any adjustments.

1. First insure that you have install the correct blade into the jigsaw for the material and design you are about to Cut. Wood blade all types of Wood and a metal Blade for Metals and plastics.
2. Before starting the scroll saw or installing a POWERhandle into the charger dock adjust the table clamp so that the it firmly presses your work piece against the work surface but still allows easy movement.
3. Align the first cut with the cutting face of the blade with a small gap, holding your work piece with your right hand start the scroll saw with your left.
4. Grip you work pieces on both sides of the table clamp and gently push it into the cutting face of the scroll saw, firmly but smoothly guide the work over the blade following your marked design. Depending on the material of your work piece you might have to blow the dust away to keep good visibility of your marked cut line.
5. When you have completed you cut hold the work stead with you right hand and stop the scroll saw with your left.

## Making Bevel Cuts

The jigsaw can be adjusted to lean 10° in either direction to enable a Bevel cut.

## Making pocket Cuts

1. Use the drill press or drill to bore a hole on the inside of the area you want to remove, close to the cutting line. ensure that the drill diameter is great than the blade with by 1 or 2mm
2. Place the hole over the scroll saw blade and align the cutting face of the blade with the direction of cut and your marked line. For this operation you will have to remove the Table clamp or slide your work under neath it. Now continue to stage 2 of 'Making Cuts'.

## Making Tight or Corner Cuts

**NOTE:** *Don't try and cut a curve which is too tight by forcing the blade. This will put undue pressure on the blade causing it to snap.*

If you intend to make a pocket cut with internal rounded corners it is best to use the drill press first with the correct diameter drill.

For external corners continue your cut past the your mark and then realign the work piece with the blade facing in the correct direction.

Or

When you get to the tight external corner move the work piece gently back and forward at the same time rotating the work in the disired direction to enlarge the cut width so the blade can turn enough to align with your marked direction.

## Store the Scroll Saw Properly

**WARNING.** Always ensure that the saw is switched off and the POWERhandle is detached from the tool before disassembling the product.

1. open case lid, slide the internal plug away from the jigsaw.
2. Put internal plug back into its storage area.
3. Slide back the product lock, and roll the jigsaw away from the metal work surface finally removing the bottom of the sole plate from the lid pocket.
4. Re pack the tools into the lift out tray before putting them back into the case for storage.

**NOTE:** *The Lift Out Tray is for easy storage and protection of tools inside the Case.*

5. Disconnect the product from the mains power.

## General Inspection

Regularly check that all the fixing screws are tight. They may vibrate loose over time.

***POWER8***  
***workshop***

***13. Table Light***

## Specifications

Voltage:	18V
Bulb:	2 x 18v 0.6A Halogen
Bulb Life:	300 hours

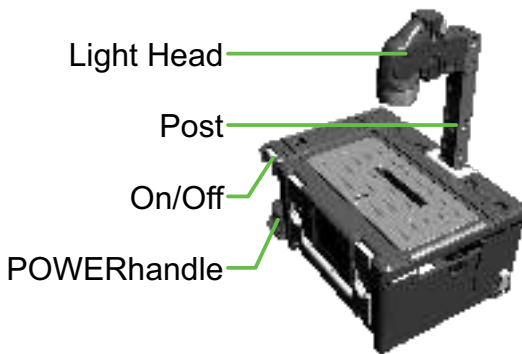

## Table Light - Operating Instructions

**Warning:** Do not install the circular saw or jigsaw into the lid of the case before starting the assemble of the table light.

**NOTE:** Never leave the table light on unattended. Turn power OFF the power by pressing the RED Button on the charger dock.

Switch off the table light and replace the battery if the light becomes noticeably running down or dim. In these case's the battery should be placed on charge.

1. Refer to 11.3 Drill Press - Operating instructions section 1 - 2 for installing the post to the Case.

2. Slide the Table Light Head up into the mating faces on the front of the post until you hear a 'click'.

3. Switch ON the light by pressing green button and switch OFF the light by pressing red button. On the charger dock.

### Rotate the halogen Light Head

To swivel the head of the halogen light, simply move the head of the halogen light up and down as require. Continue to adjust the light until it meets your requirements.

**NOTE:** The flashing function of the halogen light is disabled when fitted to the post.

***POWER8***  
***workshop***

***14. Spirit Level and Protractor***

1. Angle markings
2. Angle release knob
3. Angle indicator
4. Spirit level (1of3)
5. Post lock holes
6. Finger recess
7. Post hook
8. Post head release button
9. Post head pivot
10. Post head (sliding part)
11. Handle pin location hole
12. Handle pin location slot
13. Electrical contacts
14. Post head (swing part)
15. Post hook (active)
16. Product release latch
17. Post lever

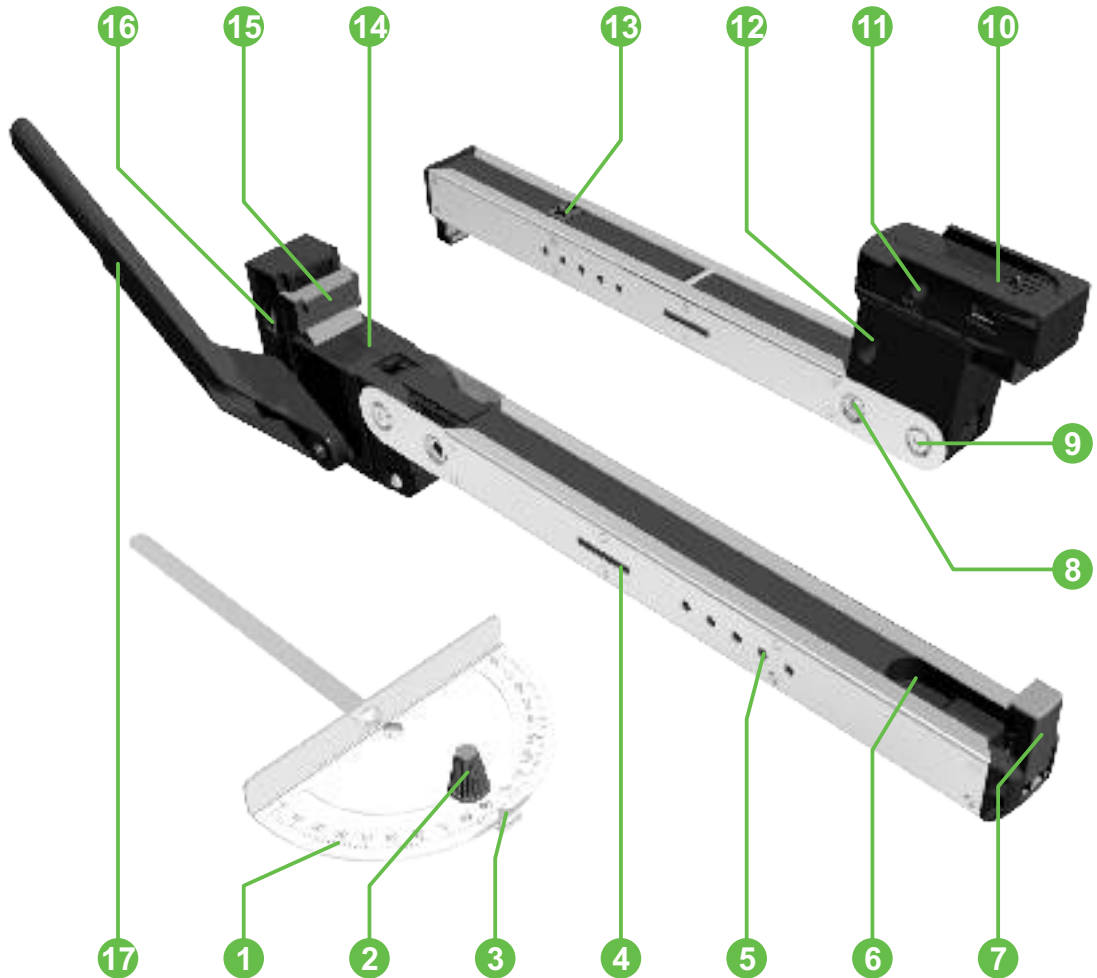



*Making Shelves  
and pictures Level*

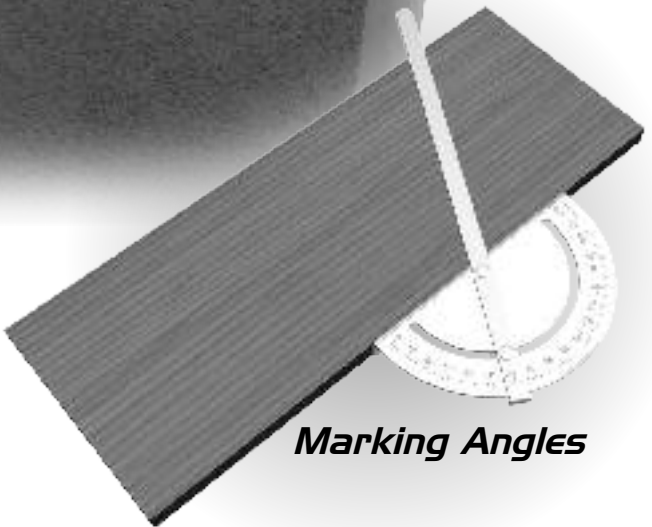

*Marking Angles*



## **Extended Functions of the Post**

The post is fitted with 3 spirit levels, so it can also be used as a conventional spirit level. This Helps when fitting Shelf, Picture frames and other wall mounted item correctly.

## **Extended Function of the Protractor**

The protractor can be used to measure angles and mark up work. It can also be used as a set square.

Table Saw	Won't switch on.	Check that the table saw shield is correctly assembled to the bottom of the circular saw before assembling it into the case.	10.3.1-4
		Ensure that the internal power coupling is correctly assembled onto the circular saw.	10.3.7
		Check that the case lid and both latches are fully closed.	10.3.8
		Ensure there is a CHARGED POWERhandle in the charger dock.	10.3
	Difficult to install parallel fence.	Check that the green hook is fully under the ledge of the lid before lowering the locking end of the post to the work surface.	10.3.9
		Check that the post is being assembled parallel with the front or rear edge of the case; use the ruled scale to check.	10.3.9
		Before lowering the locking part of the post to the work surface ensure the moving hook is open and can easily move under the ledge on the charger dock.	10.3.9
Difficult to remove the fence.	To release the fence, Ensure that the sliding part of the post is up and away from the case, then rotate the post up around the green hook on the other end.	10.3.9	
Drill Press	Won't switch on.	Ensure that the circular saw or jigsaw is not assembled to the underside of the case lid.	11.4
		Check that the drill head is fully assembled into the post and the green locking latch is forward.	11.4
		Ensure the post is assembled below the first locking position.	11.4

		Check that the case lid and both latches are fully closed. Ensure there is a CHARGED POWERhandle in the charger dock.	11.4
	Post won't slide up or down.	The green lever at the back of the case must be up for the post to move.	11.3.2
	Post is not locked in position.	Ensure that the green lock lever is completely down and the locking pins on the case are lined up with the mating holes on the post.	11.3.2
Scroll Saw	Won't switch on.	Ensure that the jigsaw is correctly assembled onto the underside of the case lid.	12.3
		Ensure that the internal power coupling is correctly assembled onto the jigsaw.	12.3
		Check that the case lid and both latches are fully closed.	12.3.5
		Ensure there is a CHARGED POWERhandle in the charger dock.	12.3
POWERhandle	Will not charge in the dock.	Check that the main power is connected and turned on.	4.4
		Check that the SCP (Secondary Charger Position) is correctly packed into the pocket.	4.4
		Check that the POWERhandle is fully inserted into the dock	4.3
		Check the fuse on the plug ( <i>mains plug fuses are not fitted in all countries</i> )	



<u>Parts / Accessory:</u>	<u>Part Number:</u>
POWERhandle	WS1-PH01
Table Saw Shield	WS1-TSS01
Work Clamp	WS1-WC01
Protractor	WS1-PT01
Post Lever / Push Stick	WS1-PL01
Post / Fence	WS1-PF01
Dust Extration Connector	WS1-DEC01
Halogen Light Bulb	WS1-HB01
Carrying Bag	WS1-CB01
Lift Out Tray - Upper	WS1-LOU01
Lift Out Tray - Lower	WS1-LOL01
Accessory Case	WS1-AC01
Accessory Case Pack: Standard Pack 1	WS1-ACP01
Standard Pack 2	WS1-ACP02

Please contact the stores where you purchased the **POWER8workshop**, or the nearest authorized dealer for information on ordering additional parts and accessories. Thanks for your investment, new innovative products and accessories will be developed and launched in the near future. You can visit our website **[www.POWER8workshop.com](http://www.POWER8workshop.com)** for further information, please feel free to email: **[parts@POWER8workshop.com](mailto:parts@POWER8workshop.com)** with all your comments or **Tel: 08453 88 97 69**



C Enterprise Limited [www.cel-global.com](http://www.cel-global.com) [info@cel-global.com](mailto:info@cel-global.com)  
UK • HK • USA • China • Europe • Australia • Japan