

# Service Instructions

Split System Air Conditioners and  
Split System Heat Pumps  
with R-22 Refrigerant  
Blowers, Coils, & Accessories

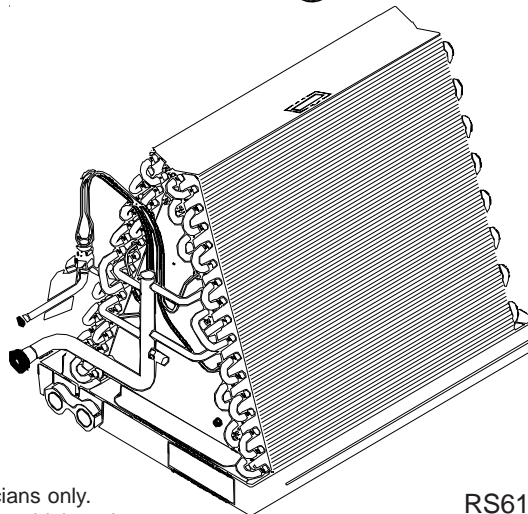
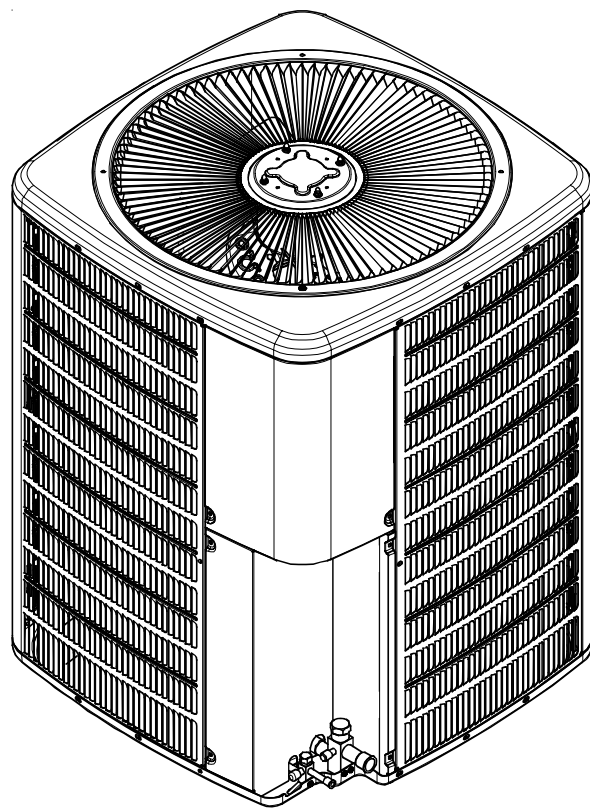
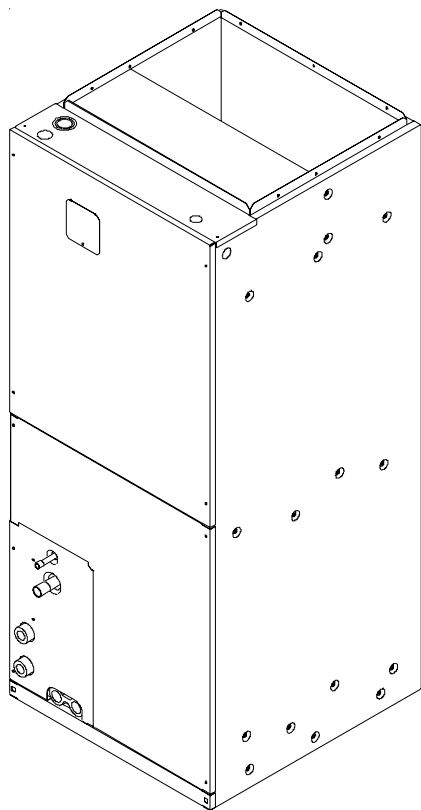

This manual is to be used by qualified, professionally trained HVAC technicians only. Goodman does not assume any responsibility for property damage or personal injury due to improper service procedures or services performed by an unqualified person.

RS6100004 Rev. 1  
November 2006

# TABLE OF CONTENTS

IMPORTANT INFORMATION .....	2 - 3	SYSTEM OPERATION .....	15 - 19
MODEL IDENTIFICATION .....	4 - 6	TROUBLESHOOTING CHART .....	20
AIR HANDLER/COIL IDENTIFICATION .....	7 - 8	SERVICING TABLE OF CONTENTS .....	21
ACCESSORIES .....	9 - 13	SERVICING .....	21 - 51
PRODUCT DESIGN .....	14	ACCESSORIES WIRING DIAGRAMS .....	52 - 56

## IMPORTANT INFORMATION

Pride and workmanship go into every product to provide our customers with quality products. It is possible, however, that during its lifetime a product may require service. Products should be serviced only by a qualified service technician who is familiar with the safety procedures required in the repair and who is equipped with the proper tools, parts, testing instruments and the appropriate service manual. **REVIEW ALL SERVICE INFORMATION IN THE APPROPRIATE SERVICE MANUAL BEFORE BEGINNING REPAIRS.**

## IMPORTANT NOTICES FOR CONSUMERS AND SERVICERS RECOGNIZE SAFETY SYMBOLS, WORDS AND LABELS



### WARNING

This unit should not be connected to, or used in conjunction with, any devices that are not design certified for use with this unit or have not been tested and approved by Goodman. Serious property damage or personal injury, reduced unit performance and/or hazardous conditions may result from the use of devices that have not been approved or certified by Goodman.



### WARNING

Installation and repair of this unit should be performed **ONLY** by individuals meeting the requirements of an "Entry Level Technician" as specified by the Air Conditioning and Refrigeration Institute (ARI). Attempting to install or repair this unit without such background may result in product damage, personal injury, or death.



### WARNING

To prevent the risk of property damage, personal injury, or death, do not store combustible materials or use gasoline or other flammable liquids or vapors in the vicinity of this appliance.



### WARNING

Goodman will not be responsible for any injury or property damage arising from improper service or service procedures. If you perform service on your own product, you assume responsibility for any personal injury or property damage which may result.

To locate an authorized servicer, please consult your telephone book or the dealer from whom you purchased this product. For further assistance, please contact:

**CONSUMER INFORMATION LINE  
GOODMAN® BRAND PRODUCTS  
TOLL FREE 1-877-254-4729 (U.S. only)**  
email us at: [customerservice@goodmanmfg.com](mailto:customerservice@goodmanmfg.com)  
fax us at: (731) 856-1821  
(Not a technical assistance line for dealers.)

**CONSUMER INFORMATION LINE  
AMANA® BRAND PRODUCTS  
TOLL FREE 1-877-254-4729 (U.S. only)**  
email us at: [hac.consumer.affairs@amanahvac.com](mailto:hac.consumer.affairs@amanahvac.com)  
fax us at: (931) 438-4362  
(Not a technical assistance line for dealers.)

Outside the U.S., call 1-713-861-2500. (Not a technical assistance line for dealers.) Your telephone company will bill you for the call.

Outside the U.S., call 1-931-433-6101. (Not a technical assistance line for dealers.) Your telephone company will bill you for the call.

# IMPORTANT INFORMATION

## SAFE REFRIGERANT HANDLING

While these items will not cover every conceivable situation, they should serve as a useful guide.



### WARNING

Refrigerants are heavier than air. They can "push out" the oxygen in your lungs or in any enclosed space. To avoid possible difficulty in breathing or death:

- Never purge refrigerant into an enclosed room or space. By law, all refrigerants must be reclaimed.
- If an indoor leak is suspected, thoroughly ventilate the area before beginning work.
- Liquid refrigerant can be very cold. To avoid possible frostbite or blindness, avoid contact with refrigerant and wear gloves and goggles. If liquid refrigerant does contact your skin or eyes, seek medical help immediately.
- Always follow EPA regulations. Never burn refrigerant, as poisonous gas will be produced.



### WARNING

To avoid possible explosion:

- Never apply flame or steam to a refrigerant cylinder. If you must heat a cylinder for faster charging, partially immerse it in warm water.
- Never fill a cylinder more than 80% full of liquid refrigerant.
- Never add anything other than R-22 to an R-22 cylinder or R-410A to an R-410A cylinder. The service equipment used must be listed or certified for the type of refrigerant used.
- Store cylinders in a cool, dry place. Never use a cylinder as a platform or a roller.



### WARNING

#### HIGH VOLTAGE

Disconnect ALL power before servicing or installing this unit. Multiple power sources may be present. Failure to do so may cause property damage, personal injury or death.



### WARNING

To avoid possible injury, explosion or death, practice safe handling of refrigerants.



### WARNING

To avoid possible explosion, use only returnable (not disposable) service cylinders when removing refrigerant from a system.

- Ensure the cylinder is free of damage which could lead to a leak or explosion.
- Ensure the hydrostatic test date does not exceed 5 years.
- Ensure the pressure rating meets or exceeds 400 lbs.

When in doubt, do not use cylinder.



### WARNING

System contaminants, improper service procedure and/or physical abuse affecting hermetic compressor electrical terminals may cause dangerous system venting.

The successful development of hermetically sealed refrigeration compressors has completely sealed the compressor's moving parts and electric motor inside a common housing, minimizing refrigerant leaks and the hazards sometimes associated with moving belts, pulleys or couplings.

Fundamental to the design of hermetic compressors is a method whereby electrical current is transmitted to the compressor motor through terminal conductors which pass through the compressor housing wall. These terminals are sealed in a dielectric material which insulates them from the housing and maintains the pressure tight integrity of the hermetic compressor. The terminals and their dielectric embedment are strongly constructed, but are vulnerable to careless compressor installation or maintenance procedures and equally vulnerable to internal electrical short circuits caused by excessive system contaminants.

In either of these instances, an electrical short between the terminal and the compressor housing may result in the loss of integrity between the terminal and its dielectric embedment. This loss may cause the terminals to be expelled, thereby venting the vaporous and liquid contents of the compressor housing and system.

A venting compressor terminal normally presents no danger to anyone, providing the terminal protective cover is properly in place.

If, however, the terminal protective cover is not properly in place, a venting terminal may discharge a combination of

- (a) hot lubricating oil and refrigerant
- (b) flammable mixture (if system is contaminated with air)

in a stream of spray which may be dangerous to anyone in the vicinity. Death or serious bodily injury could occur.

Under no circumstances is a hermetic compressor to be electrically energized and/or operated without having the terminal protective cover properly in place.

See Service Section S-17 for proper servicing.

# PRODUCT IDENTIFICATION

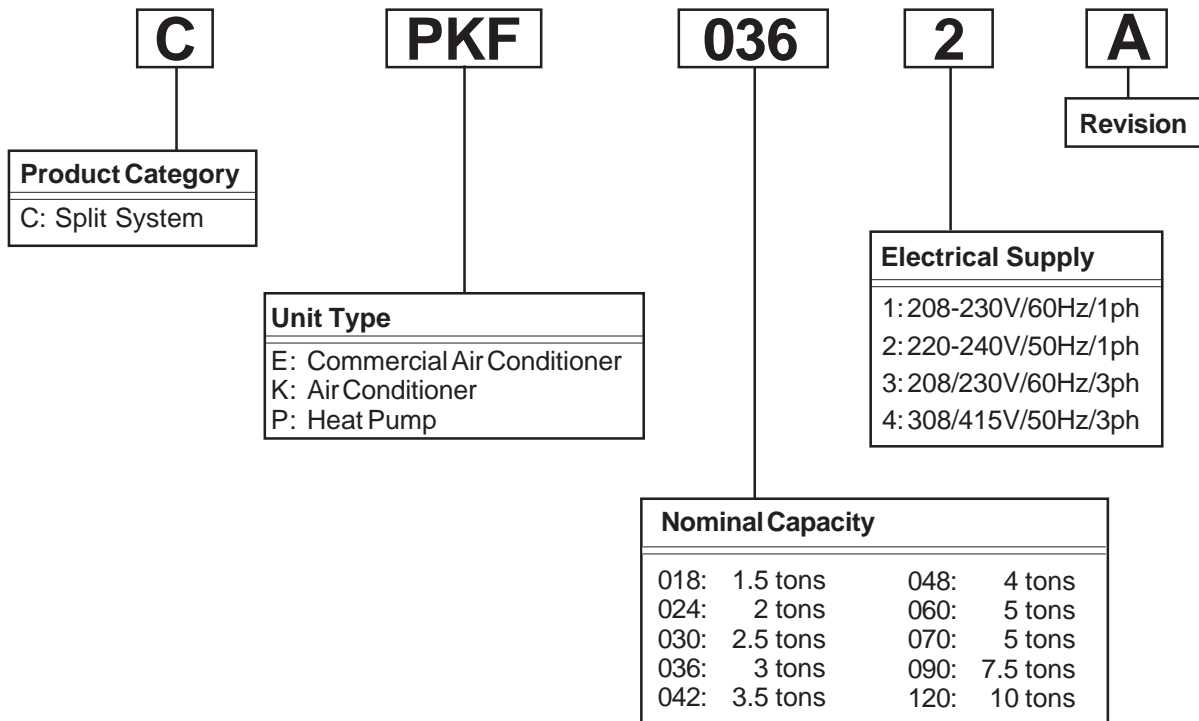
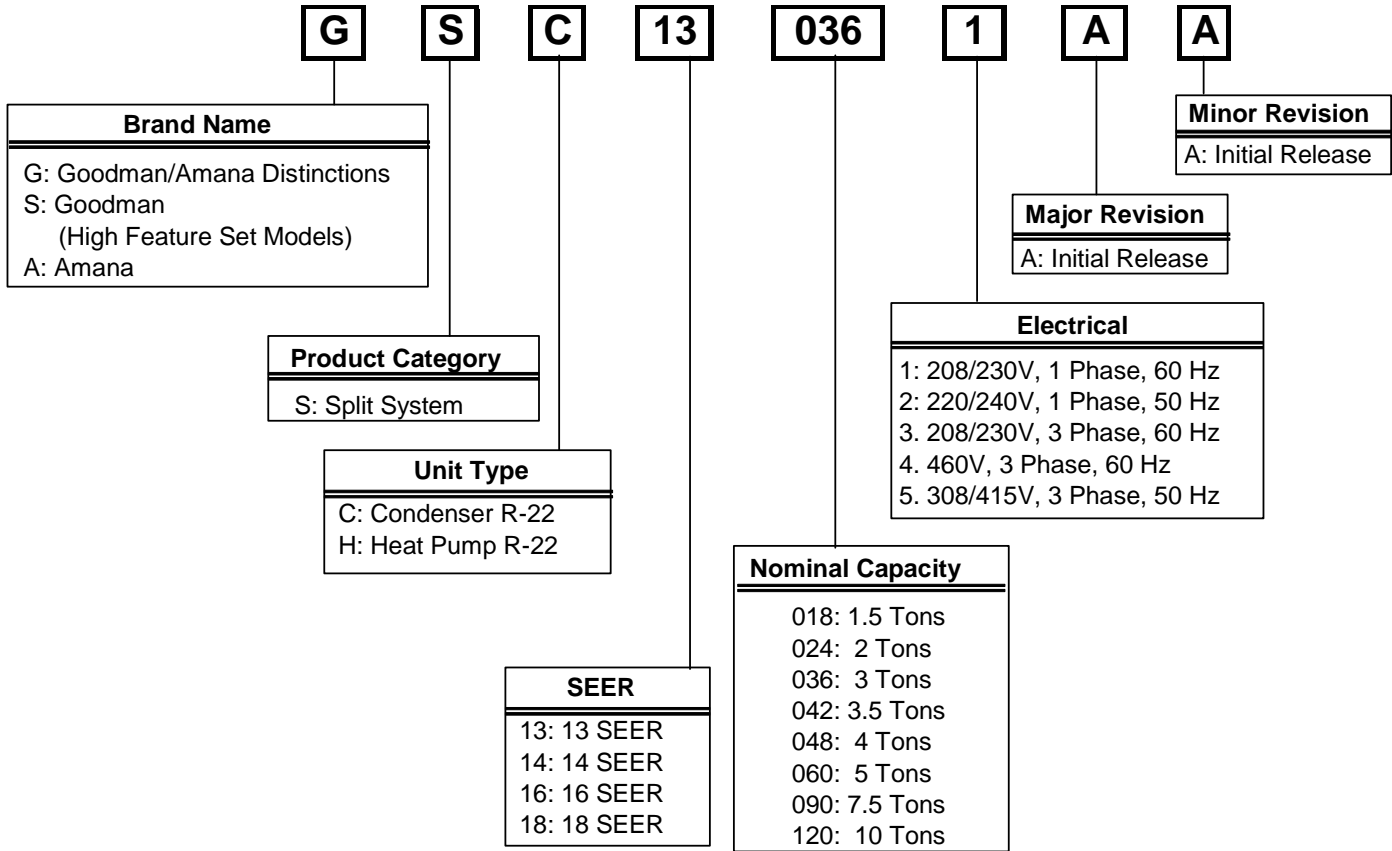

# PRODUCT IDENTIFICATION

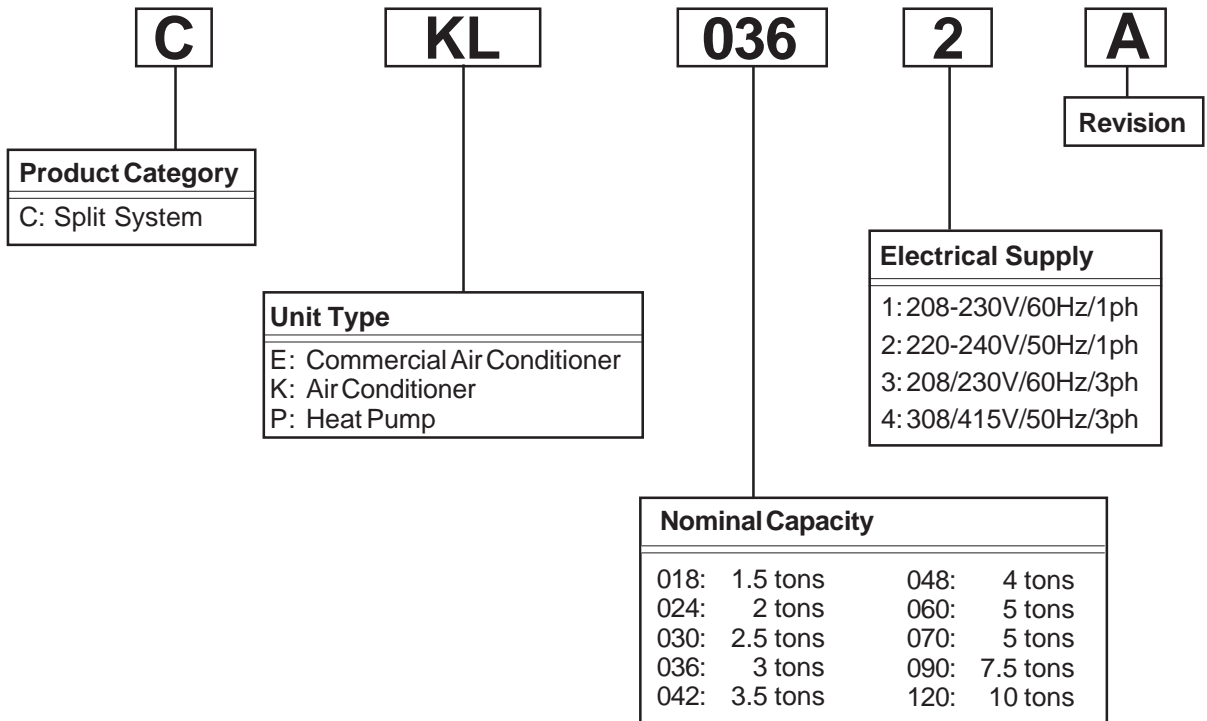
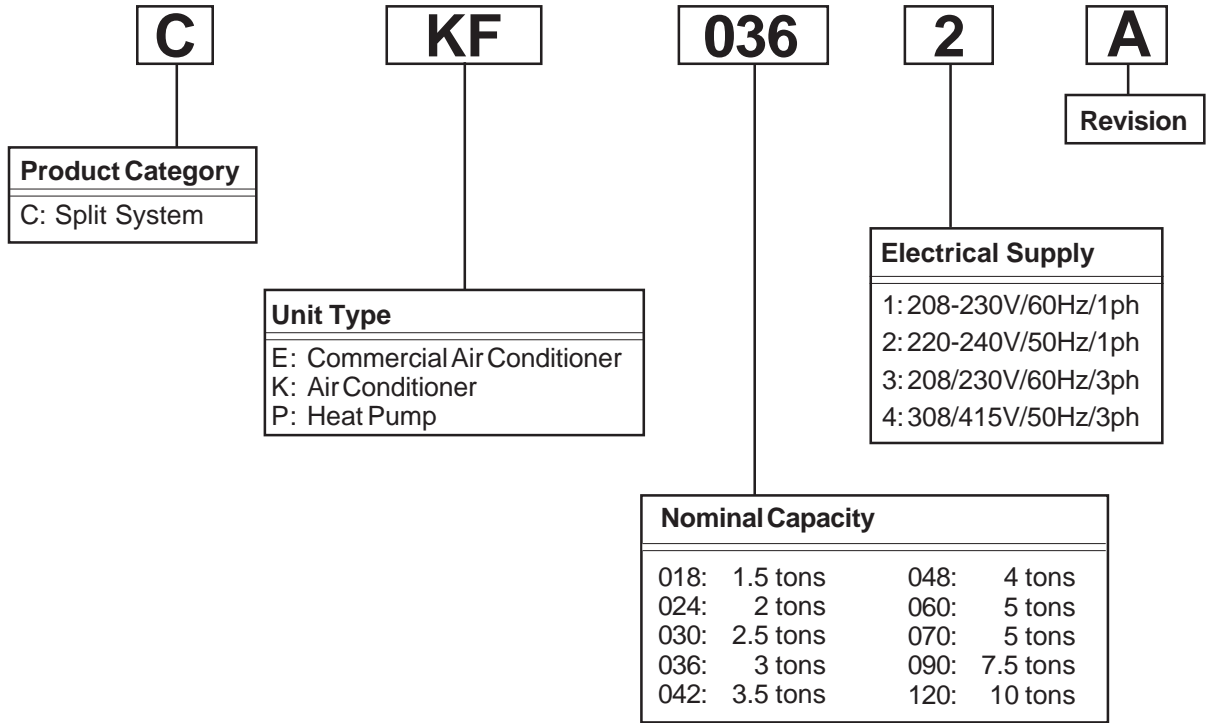

# PRODUCT IDENTIFICATION

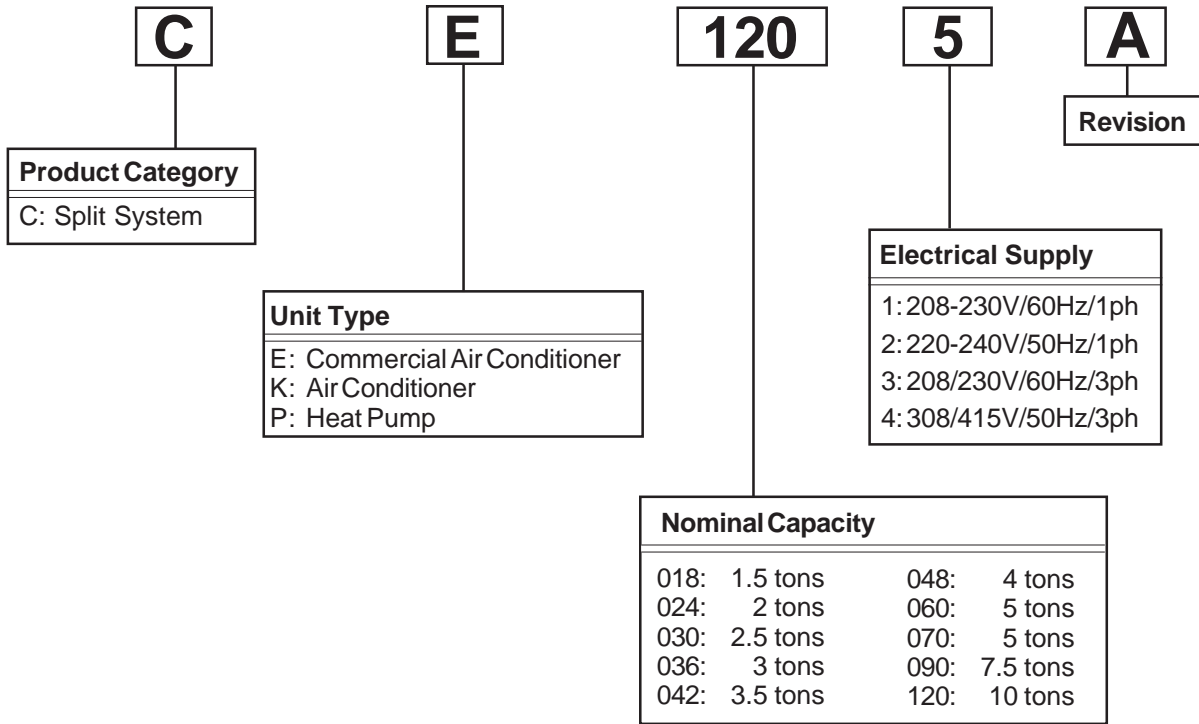

# PRODUCT IDENTIFICATION

THIS NOMENCLATURE IS TO BE USED THROUGH JULY 2006

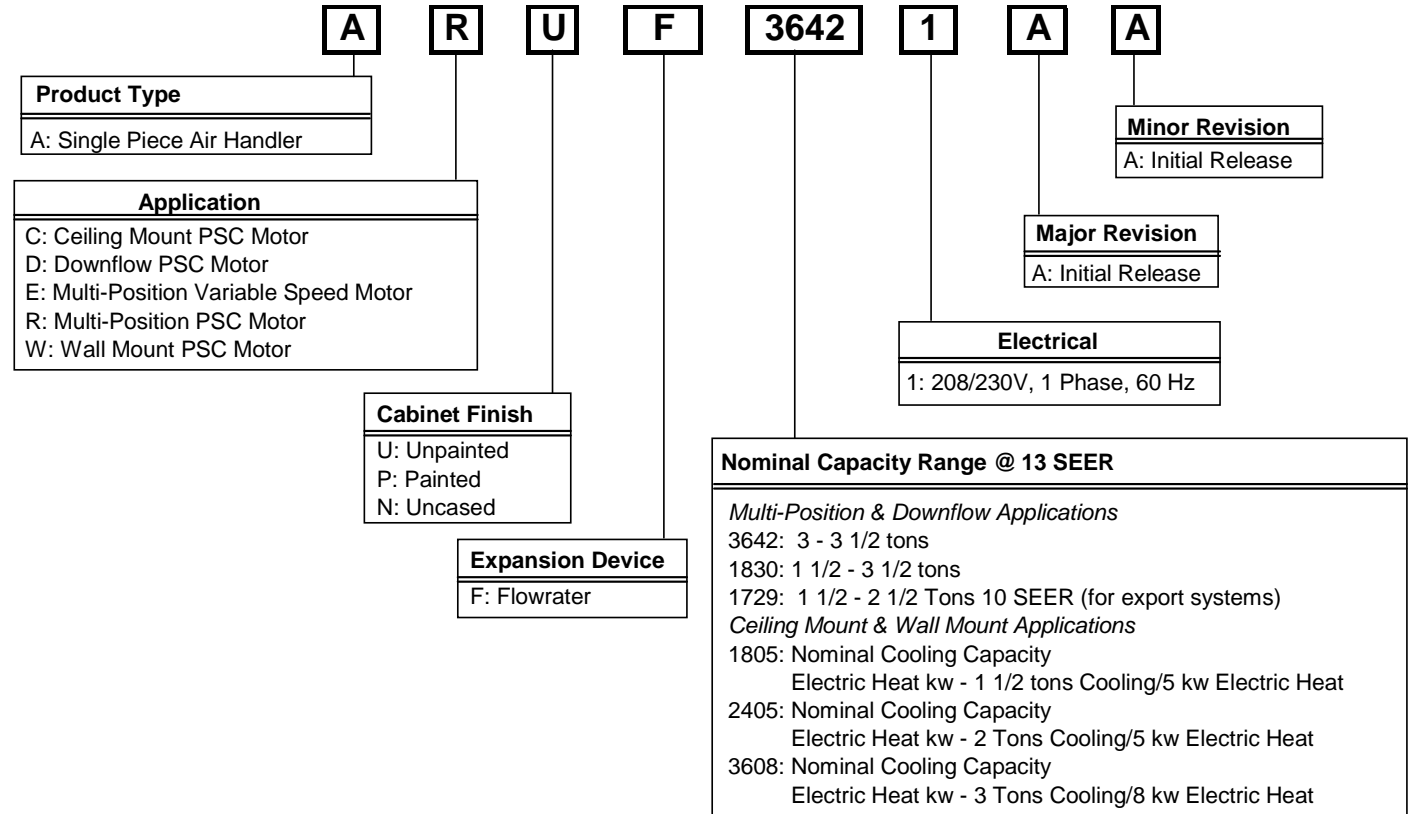

THIS NOMENCLATURE IS TO BE USED AFTER JULY 2006

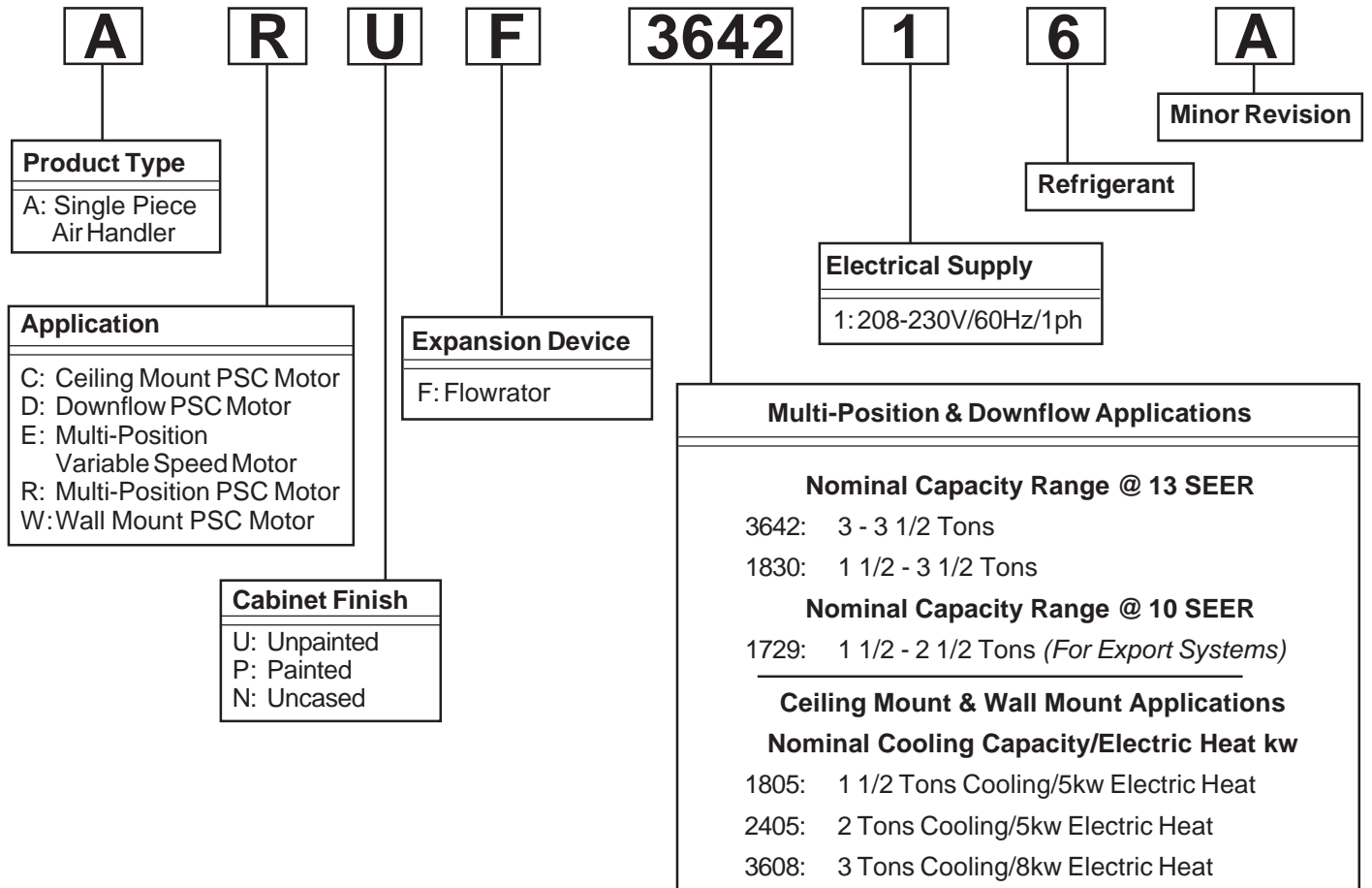

# PRODUCT IDENTIFICATION

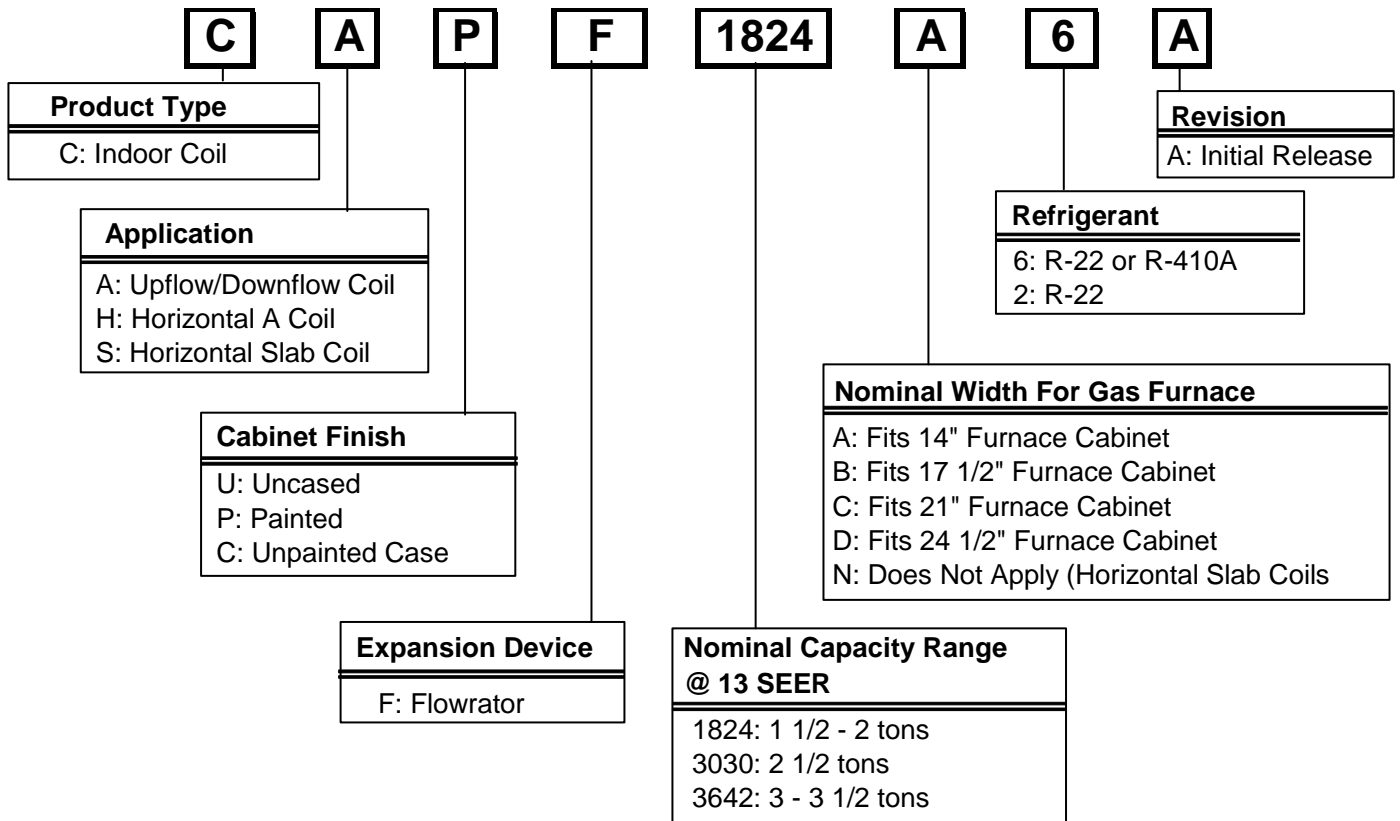
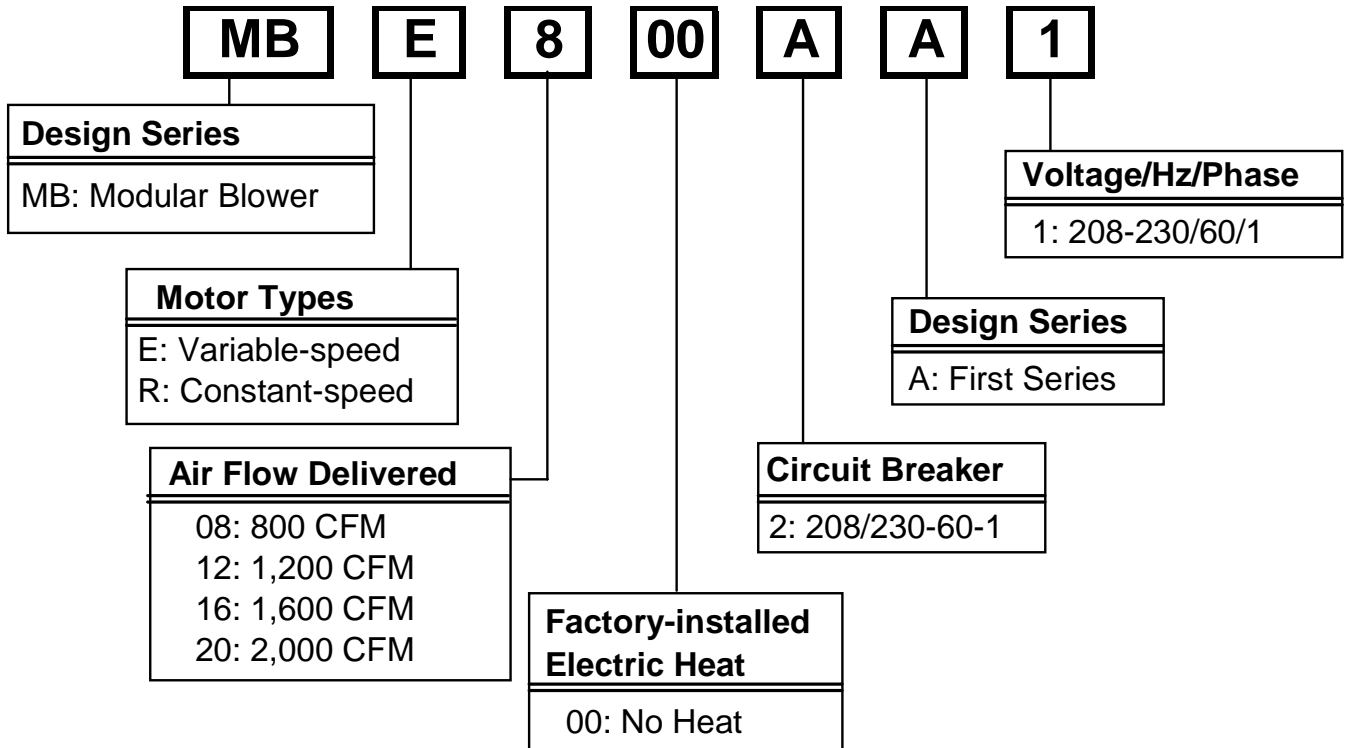



# ACCESSORIES

Model	Description	GSH13018	GSH13024	GSH13030	GSH13036	GSH13042	GSH13048	GSH13060
AFE18-60A	All Fuel Kit	X	X	X	X	X	X	X
OT18-60A	Outdoor Thermostat	X	X	X	X	X	X	X
FSK01A*	Freeze Protection Kit	X	X	X	X	X	X	X
ASC01	Anti Short Cycle Kit	X	X	X	X	X	X	X
TX2N2*	TXV Kit	X	---	---	---	---	---	---
TX3N2*	TXV Kit	X	X	X	X	---	---	---
TX5N2*	TXV Kit	---	---	---	---	X	X	X
OT18-60A	Outdoor Lockout Stat	X	X	X	X	X	X	X
OT/EHR18-60	Emergency Heat relay kit	X	X	X	X	X	X	X
CSR-U-1	Hard Start Kit	X	X	X	X	---	---	---
CSR-U-2	Hard Start Kit	---	---	---	X	X	X	X
CSR-U-3	Hard Start Kit	---	---	---	---	---	X	X

Model	Description	ASH13018	ASH13024	ASH13030	ASH13036	ASH13042	ASH13048	ASH13060
AFE18-60A	All Fuel Kit	X	X	X	X	X	X	X
OT18-60A	Outdoor Thermostat	X	X	X	X	X	X	X
FSK01A*	Freeze Protection Kit	X	X	X	X	X	X	X
ASC01	Anti Short Cycle Kit	X	X	X	X	X	X	X
TX2N2*	TXV Kit	X	---	---	---	---	---	---
TX3N2*	TXV Kit	X	X	X	X	---	---	---
TX5N2*	TXV Kit	---	---	---	---	X	X	X
OT18-60A	Outdoor Lockout Stat	X	X	X	X	X	X	X
OT/EHR18-60	Emergency Heat relay kit	X	X	X	X	X	X	X
CSR-U-1	Hard Start Kit	X	X	X	X	---	---	---
CSR-U-2	Hard Start Kit	---	---	---	X	X	X	X
CSR-U-3	Hard Start Kit	---	---	---	---	---	X	X

Model	Description	ASC13018	ASC13024	ASC13030	ASC13036	ASC13042	ASC13048	ASC13060
OT18-60A	Outdoor Thermostat	---	---	---	---	---	---	---
FSK01A*	Freeze Protection Kit	X	X	X	X	X	X	X
ASC01	Anti Short Cycle Kit	X	X	X	X	X	X	X
TX2N2*	TXV Kit	X	---	---	---	---	---	---
TX3N2*	TXV Kit	X	X	X	X	---	---	---
TX5N2*	TXV Kit	---	---	---	---	X	X	X
CSR-U-1	Hard Start Kit	X	X	X	X	---	---	---
CSR-U-2	Hard Start Kit	---	---	---	X	X	X	X
CSR-U-3	Hard Start Kit	---	---	---	---	---	X	X

Model	Description	GSC13018	GSC13024	GSC13030	GSC13036	GSC13042	GSC13048	GSC13060
OT18-60A	Outdoor Thermostat	---	---	---	---	---	---	---
FSK01A*	Freeze Protection Kit	X	X	X	X	X	X	X
ASC01	Anti Short Cycle Kit	X	X	X	X	X	X	X
TX2N2*	TXV Kit	X	---	---	---	---	---	---
TX3N2*	TXV Kit	X	X	X	X	---	---	---
TX5N2*	TXV Kit	---	---	---	---	X	X	X
CSR-U-1	Hard Start Kit	X	X	X	X	---	---	---
CSR-U-2	Hard Start Kit	---	---	---	X	X	X	X
CSR-U-3	Hard Start Kit	---	---	---	---	---	X	X

\*Installed on indoor coil.

# ACCESSORIES

Model	Description	CPKF24	CPKF36	CPKF42	CPKF48	CPKF60	CPKF61
AFE18-60A	All Fuel Kit	X	X	X	X	X	X
OT18-60A	Outdoor Thermostat	X	X	X	X	X	X
FSK01A*	Freeze Protection Kit	X	X	X	X	X	X
ASC01	Anti Short Cycle Kit	X	X	X	X	X	X
TX2N2*	TXV Kit	---	---	---	---	---	---
TX3N2*	TXV Kit	X	X	---	---	---	---
TX5N2*	TXV Kit	---	---	X	X	X	X
OT18-60A	Outdoor Lockout Stat	X	X	X	X	X	X
OT/EHR18-60	Emergency Heat relay kit	X	X	X	X	X	X
CSR-U-1	Hard Start Kit	X	X	---	---	---	---
CSR-U-2	Hard Start Kit	---	X	X	X	X	X
CSR-U-3	Hard Start Kit	---	---	---	X	X	X

Model	Description	CKF24	CKF36	CKF48	CKF60	CKF70
AFE18-60A	All Fuel Kit	---	---	---	---	---
OT18-60A	Outdoor Thermostat	---	---	---	---	---
FSK01A*	Freeze Protection Kit	X	X	X	X	X
ASC01	Anti Short Cycle Kit	X	X	X	X	X
TX2N2*	TXV Kit	---	---	---	---	---
TX3N2*	TXV Kit	X	X	---	---	---
TX5N2*	TXV Kit	---	---	X	X	---
OT18-60A	Outdoor Lockout Stat	---	---	---	---	---
OT/EHR18-60	Emergency Heat relay kit	---	---	---	---	---
CSR-U-1	Hard Start Kit	X	X	---	---	---
CSR-U-2	Hard Start Kit	---	X	X	X	---
CSR-U-3	Hard Start Kit	---	---	X	X	---

Model	Description	CKL18	CKL24	CKL30	CKL36	CKL42	CKL49	CKL60
AFE18-60A	All Fuel Kit	---	---	---	---	---	---	---
OT18-60A	Outdoor Thermostat	---	---	---	---	---	---	---
FSK01A*	Freeze Protection Kit	X	X	X	X	X	X	X
ASC01	Anti Short Cycle Kit	X	X	X	X	X	X	X
TX2N2*	TXV Kit	X	---	---	---	---	---	---
TX3N2*	TXV Kit	X	X	X	X	---	---	---
TX5N2*	TXV Kit	---	---	---	---	X	X	X
OT18-60A	Outdoor Lockout Stat	---	---	---	---	---	---	---
OT/EHR18-60	Emergency Heat relay kit	---	---	---	---	---	---	---
CSR-U-1	Hard Start Kit	X	X	X	X	---	---	---
CSR-U-2	Hard Start Kit	---	---	---	X	X	X	X
CSR-U-3	Hard Start Kit	---	---	---	---	---	X	X

Model	Description	CE120
AFE18-60A	All Fuel Kit	---
OT18-60A	Outdoor Thermostat	---
FSK01A*	Freeze Protection Kit	X
ASC01	Anti Short Cycle Kit	X
TX2N2*	TXV Kit	---
TX3N2*	TXV Kit	---
TX5N2*	TXV Kit	---
OT18-60A	Outdoor Lockout Stat	---
OT/EHR18-60	Emergency Heat relay kit	---
CSR-U-1	Hard Start Kit	---
CSR-U-2	Hard Start Kit	---
CSR-U-3	Hard Start Kit	---

# ACCESSORIES

## EXPANSION VALVE KITS

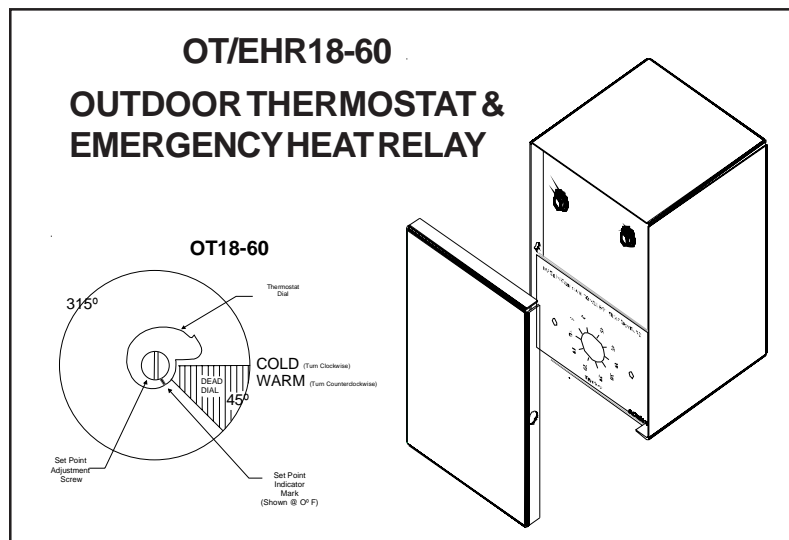
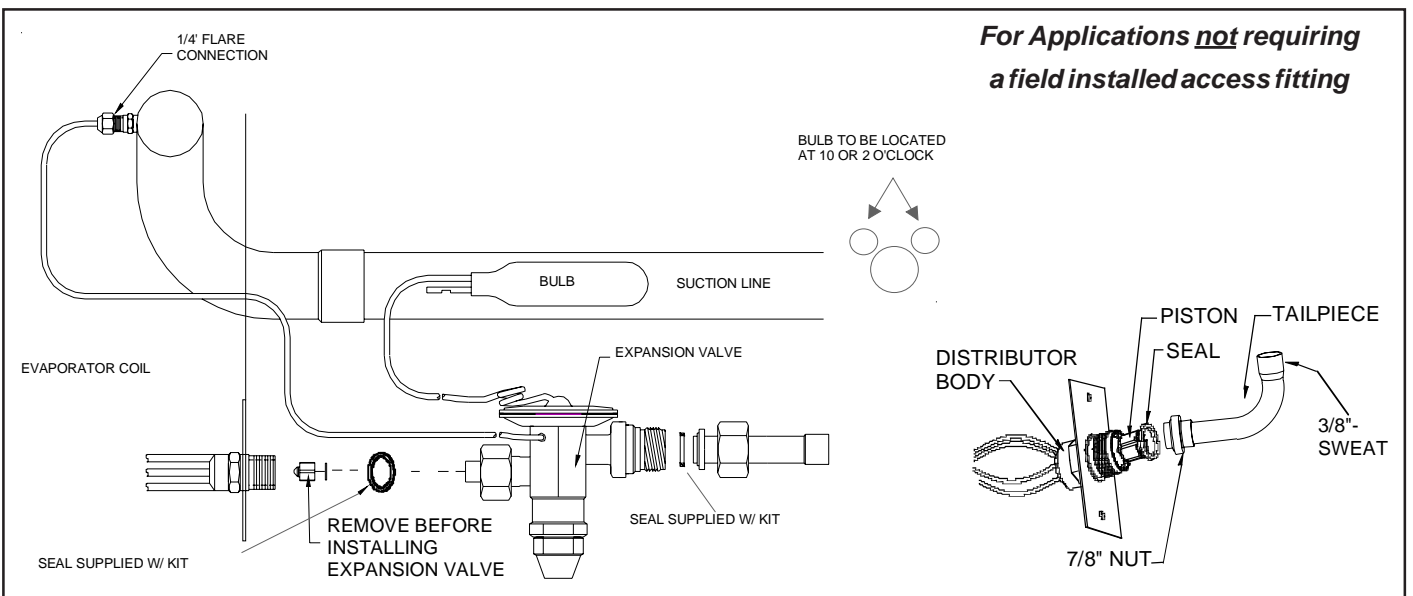
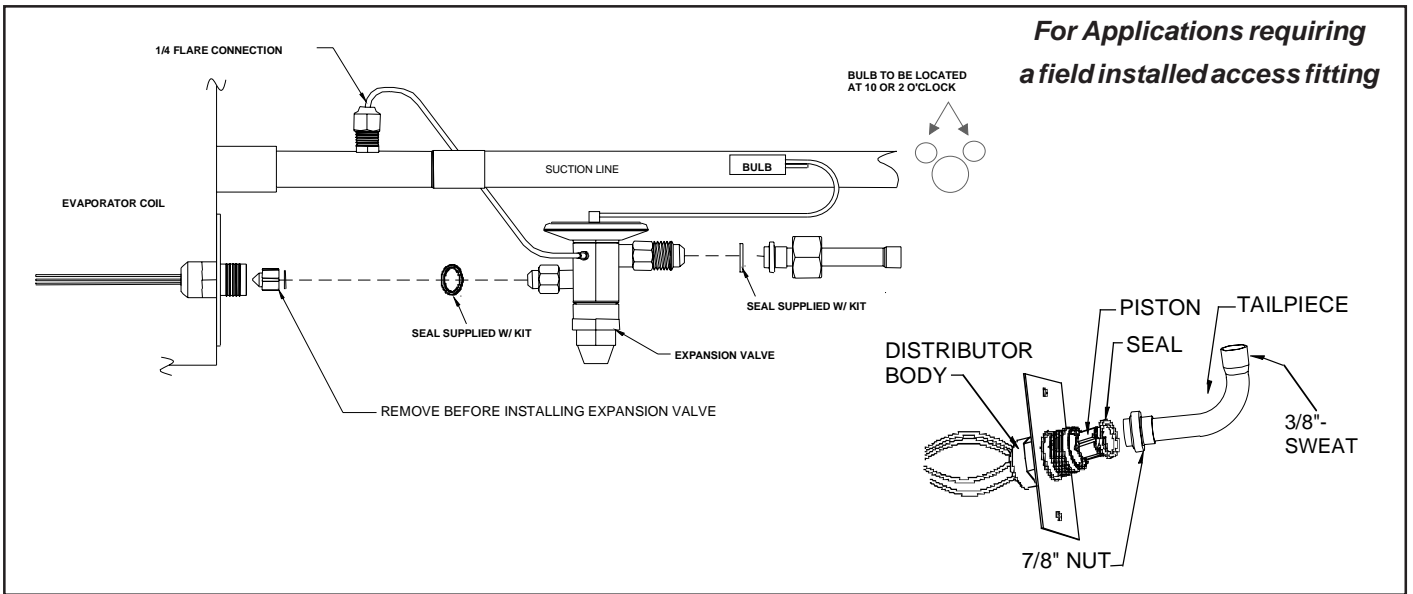

# ACCESSORIES

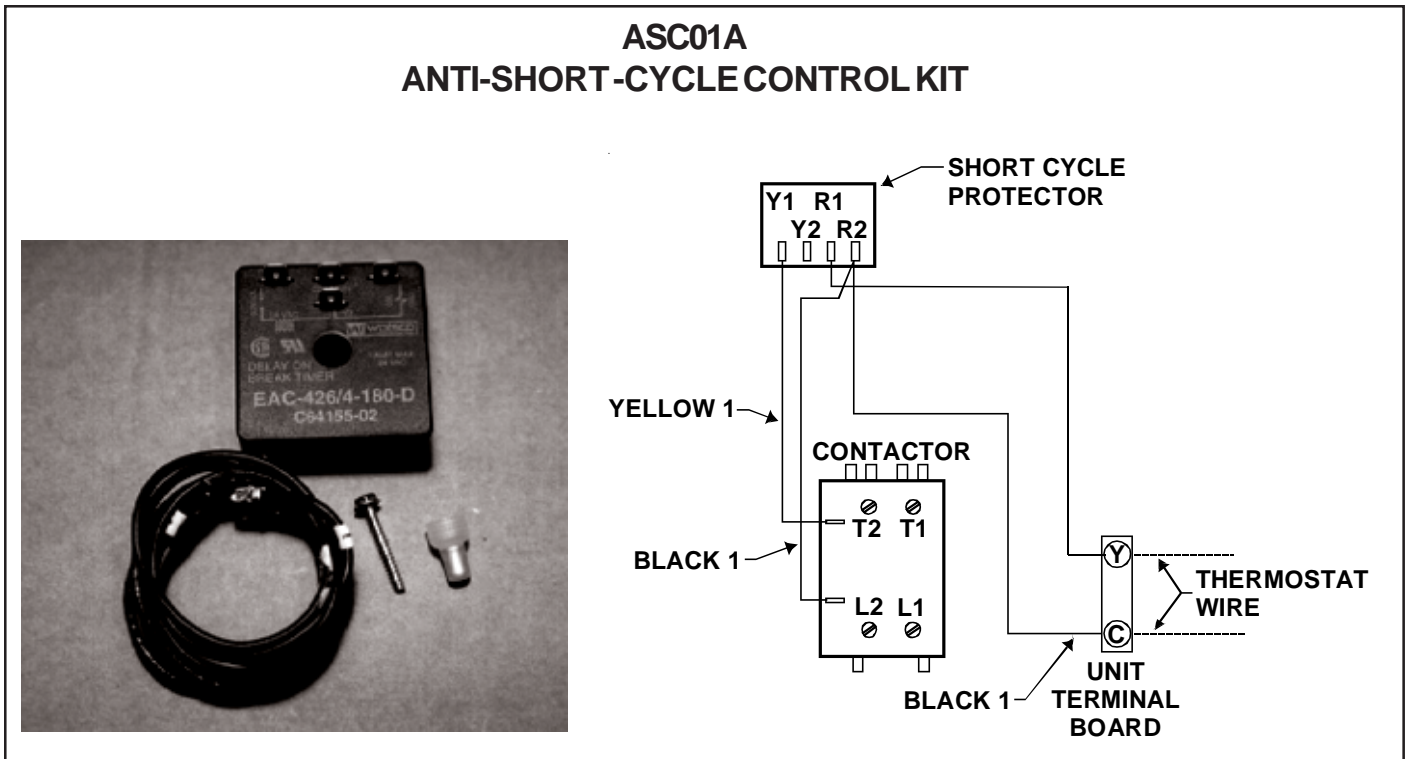
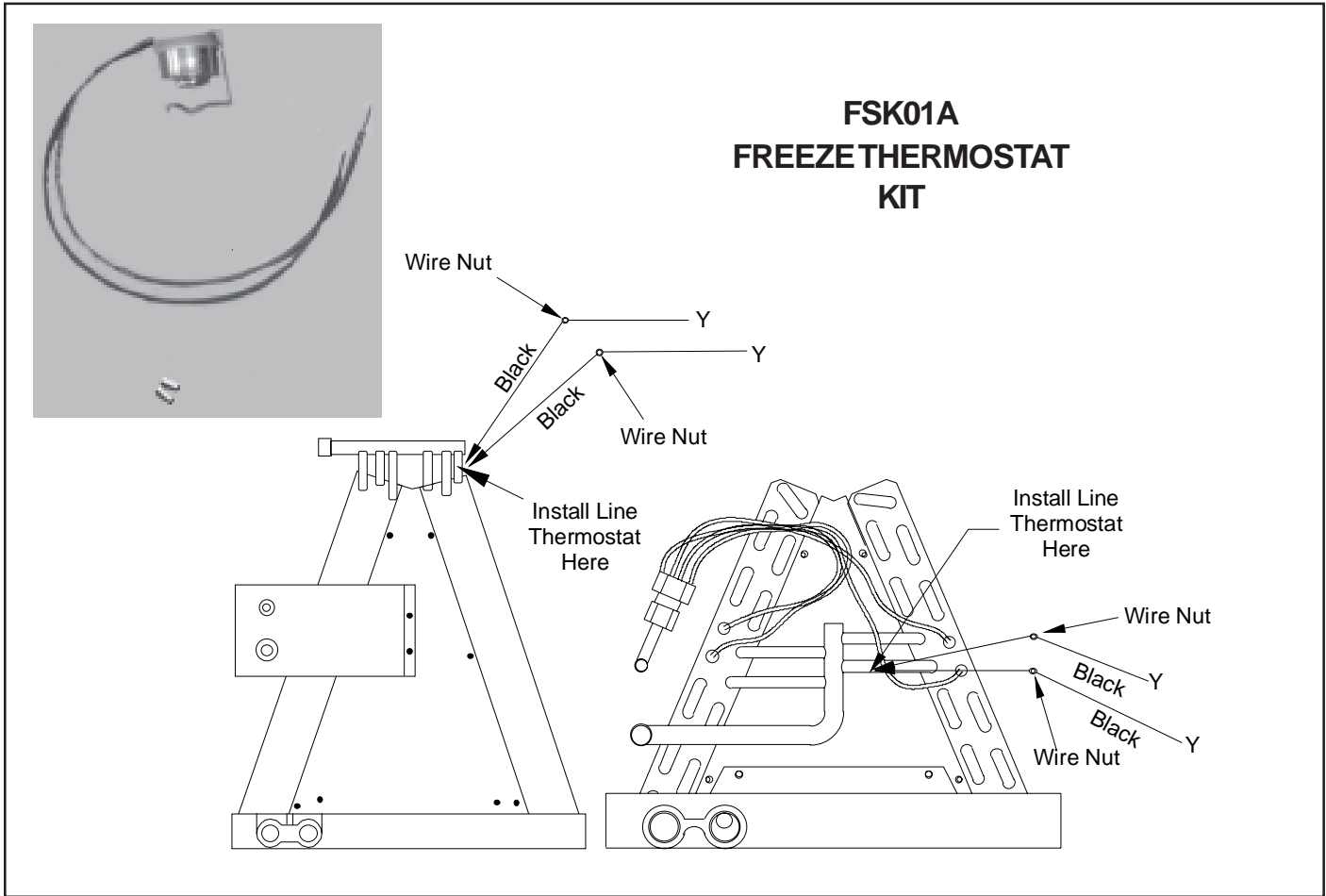

# ACCESSORIES

## COIL ACCESSORIES

COIL MODEL	TX2N2 TXV KIT	TX3N2 TXV KIT	TX5N2 TXV KIT	FSK01A FREEZE PROTECTION KIT
CA*F030B4*	---	X	---	X
CA*F036B4*	---	X	---	X
CA*F042C4*	---	---	X	X
CA*F048C4*	---	---	X	X
CA*F057D4*	---	---	X	X
CA*F060D4*	---	---	X	X
CHPF030A4*	---	X	---	X
CHPF036B4*	---	X	---	X
CHPF042A4*	---	---	X	X
CHPF048D4*	---	---	X	X
CHPF060D4*	---	---	X	X
CH36FCB	---	X	---	X
CH48FCB	---	---	X	X
CH60FCB	---	---	X	X
CA*F18246*	X	X	---	X
CA*F30306*	---	X	---	X
CA*F36426*	---	X	X	X
CHPF18246*	X	---	X	X
CHPF30306*	---	---	X	X
CHPF36426*	---	---	X	X
CSCF1824N6*	X	---	---	X
CSCF303N6*	---	X	---	X
CSCF3642N6*	---	X	X	X

## ELECTRIC HEAT KIT APPLICATIONS

BLOWER	ELECTRIC HEAT KIT									
	HKR-03A	HKR-05(C)A	HKR-06A	HKR-08(C)A	HKR-10(C)A	HKR-15(C)A	HKR-20(C)A	HKR-21(C)A	HKR3-15A	HKR3-20A
MBR0800AA-1	X	X	X	X	X					
MBR1200AA-1	X	X	X	X	X	X	X	X	X	X
MBR1600AA-1	X	X	X	X	X	X	X	X	X	X
MBR2000AA-1	X	X	X	X	X	X	X	X	X	X
MBE1200AA-1	-	-	-	X	X	X	-	-	-	-
MBE1600AA-1	-	-	-	-	X	X	-	-	-	-
MBE2000AA-1	-	-	-	-	X	X	X	-	-	-

X = Allowable combinations

- = Indicate restricted combinations

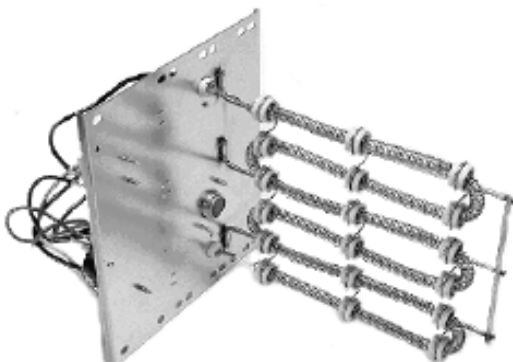

**HKR SERIES ELECTRIC HEAT KITS**

# PRODUCT DESIGN

This section gives a basic description of cooling unit operation, its various components and their basic operation. Ensure your system is properly sized for heat gain and loss according to methods of the Air Conditioning Contractors Association (ACCA) or equivalent.

## CONDENSING UNIT

These units are designed for free air discharge. Condensed air is pulled through the condenser coil by a direct drive propeller fan and then discharged from the cabinet top. The unit requires no additional resistance (i.e. duct work) and should not be added.

The GSH13, GSH14 and ASH13 Heat Pump condensing units are designed for 208-230 dual voltage single phase applications. The GSH13 3 ton model is available in 230V, 3 phase applications. The GSH13 4 and 5 ton models are available for 230V, 3-phase and 460V, 3-phase applications.

The units range in size from 1.5 to 5-ton and have a rating of 13 and 14 SEER. SEER efficiency is dependent upon the unit and its components. Refer to the "Technical Information" manual of the unit you are servicing for further details.

The GSC13, GSC14 and ASC13 Condensing Units are made in 1.5 through 5 ton sizes. They are designed for 208-240 volt single phase applications. The GSC13 3 ton model is available in 230V, 3 phase applications. The GSC13 4 and 5 ton models are available for 230V, 3-phase and 460V, 3-phase applications.

## Suction and Liquid Line Connections

All units come equipped with suction and liquid valves designed for connection to refrigerant-type copper. Front seating valves are factory-installed to accept the field-run copper. The total refrigerant charge needed for a normal operation is also factory-installed. For additional refrigerant line set information, refer to the "Technical Information" manual of the unit you are servicing.

## Compressors

GSC13 and GSH13 use a mix of reciprocating and scroll compressors. The ASC13 and ASH13 use the Copeland Scroll® Compressor. There are a number of design characteristics which differentiate the scroll compressor from the reciprocating compressor. One is the scroll. A scroll is an involute spiral which, when matched with a mating scroll form, generates a series of crescent-shaped gas pockets between the members (see following illustration). During compression, one scroll remains stationary while the other form orbits. This motion causes the resulting gas pocket to compress and push toward the center of the scrolls. When the center is reached, the gas is discharged out a port located at the compressor center.

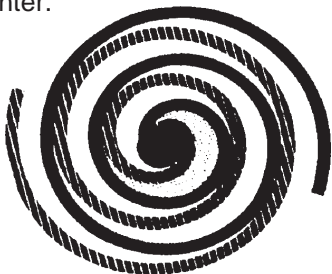

## COILS AND BLOWER COILS

MBR/MBE blower cabinets are designed to be used as a two-piece blower and coil combination. MBR/MBE blower sections can be attached to cased evaporator coil. This two-piece arrangement allows for a variety of mix-matching possibilities providing greater flexibility. The MBE blower cabinet uses a variable speed motor that maintains a constant airflow with a higher duct static.

It is approved for applications with cooling coils of up to 0.8 inches W.C. external static pressure and includes a feature that allows airflow to be changed by +15%. The MBR blower cabinet uses a PSC motor. It is approved for applications with cooling coils of up to 0.5 inches W.C. external static pressure.

The MBR/MBE blower cabinets with proper coil matches can be positioned for upflow, counterflow, horizontal right or horizontal left operation. All units are constructed with R-4.2 insulation. In areas of extreme humidity (greater than 80% consistently), insulate the exterior of the blower with insulation having a vapor barrier equivalent to ductwork insulation, providing local codes permit.

The CAPX/CHPX coils are equipped with a thermostatic expansion valve that has a built-in internal check valve for refrigerant metering. The CACF/CAPF/CHPF coils are equipped with a fixed restrictor orifice.

The coils are designed for upflow, counterflow or horizontal application, using two-speed direct drive motors on the CACF/CAPF/CHPX models and BPM (Brushless Permanent Magnet) or ECM motors on the MBE models.

The ARUF is a multi-position air handler (upflow/horizontal or downflow) and is equipped with a flowrator for cooling and heat pump applications. Because of its seamless copper tubing and aluminum fins, there are fewer leaks. The steel cabinet of the ARUF is fully insulated and rust resistant. Thermal expansion kits for air conditioning and heat pump applications are available.

ARPF\*B 2 to 5 ton air handlers are dedicated for downflow operation and are approved for modular homes. Flowrator, transformer and blower time delay are on all standard ARPF units. Both the ARUF and ARPF have direct-drive multi-speed motors.

The AEPT is a multi-position, variable-speed air handler that features a factory-installed, internally mounted TXV. The AEPT's blower motor allows for a soft start and stop for quieter, more efficient operation and also eliminates the cold blast of air upon heating startup.

# SYSTEM OPERATION

## COOLING

The refrigerant used in the system is R-22. It is a clear, colorless, non-toxic, non-irritating, and non-explosive liquid. The chemical formula is  $\text{CHClF}_2$ . The boiling point, at atmospheric pressure is  $-41.4^\circ\text{F}$ .

A few of the important principles that make the refrigeration cycle possible are: heat always flows from a warmer to a cooler body, under lower pressure a refrigerant will absorb heat and vaporize at a low temperature, the vapors may be drawn off and condensed at a higher pressure and temperature to be used again.

The indoor evaporator coil functions to cool and dehumidify the air conditioned spaces through the evaporative process taking place within the coil tubes.

**NOTE:** The pressures and temperatures shown in the refrigerant cycle illustrations on the following pages are for demonstration purposes only. Actual temperatures and pressures are to be obtained from the "Expanded Performance Chart."

Liquid refrigerant at condensing pressure and temperatures, (270 psig and  $122^\circ\text{F}$ ), leaves the outdoor condensing coil through the drier and is metered into the indoor coil through the metering device. As the cool, low pressure, saturated refrigerant enters the tubes of the indoor coil, a portion of the liquid immediately vaporizes. It continues to soak up heat and vaporizes as it proceeds through the coil, cooling the indoor coil down to about  $48^\circ\text{F}$ .

Heat is continually being transferred to the cool fins and tubes of the indoor evaporator coil by the warm system air. This warming process causes the refrigerant to boil. The heat removed from the air is carried off by the vapor.

As the vapor passes through the last tubes of the coil, it becomes superheated, that is, it absorbs more heat than is necessary to vaporize it. This is assurance that only dry gas will reach the compressor. Liquid reaching the compressor can weaken or break compressor valves.

The compressor increases the pressure of the gas, thus adding more heat, and discharges hot, high pressure superheated gas into the outdoor condenser coil.

In the condenser coil, the hot refrigerant gas, being warmer than the outdoor air, first loses its superheat by heat transferred from the gas through the tubes and fins of the coil. The refrigerant now becomes saturated, part liquid, part vapor and then continues to give up heat until it condenses to a liquid alone. Once the vapor is fully liquefied, it continues to give up heat which subcools the liquid, and it is ready to repeat the cycle.

## HEATING

The heating portion of the refrigeration cycle is similar to the cooling cycle. By energizing the reversing valve solenoid coil, the flow of the refrigerant is reversed. The indoor coil now becomes the condenser coil, and the outdoor coil becomes the evaporator coil.

The check valve at the indoor coil will open by the flow of refrigerant letting the now condensed liquid refrigerant bypass the indoor expansion device. The check valve at the outdoor coil will be forced closed by the refrigerant flow, thereby utilizing the outdoor expansion device.

The restrictor orifice used with the CA\*F, CHPF coils and the AR\*F air handler will be forced onto a seat when running in the cooling cycle, only allowing liquid refrigerant to pass through the orifice opening. In the heating cycle it will be forced off the seat allowing liquid to flow around the restrictor. A check valve is not required in this circuit.

## COOLING CYCLE

When the contacts of the room thermostat close making terminals R to Y & G, the low voltage circuit of the transformer is completed. Current now flows through the magnetic holding coils of the compressor contactor (CC) and fan relay (RFC).

This draws in the normally open contact CC, starting the compressor and condenser fan motors. At the same time contacts RFC close starting the indoor fan motor.

When the thermostat is satisfied, it opens its contacts, breaking the low voltage circuit, causing the compressor contactor and indoor fan relay to open, shutting down the system.

If the room thermostat fan selector switch should be set on the "on" position, then the indoor blower would run continuous rather than cycling with the compressor.

Heat pumps energize the reversing valve through the "O" circuit in the room thermostat. Therefore the reversing valve remains energized as long as the thermostat subbase is in the cooling position. The only exception to this is during defrost.

## DEFROST CYCLE

The defrosting of the outdoor coil is jointly controlled by the defrost timing board, defrost (30/60) control, and compressor run time.

## HEATING CYCLE

The reversing valve on the heat pump models is energized in the cooling cycle through the "O" terminal on the room thermostat.

These models have a 24 volt reversing valve coil. When the thermostat selector switch is set in the cooling position, the "O" terminal on the thermostat is energized all the time.

Care must be taken when selecting a room thermostat. Refer to the installation instructions shipped with the product for approved thermostats.



# SYSTEM OPERATION

## COOLING CYCLE

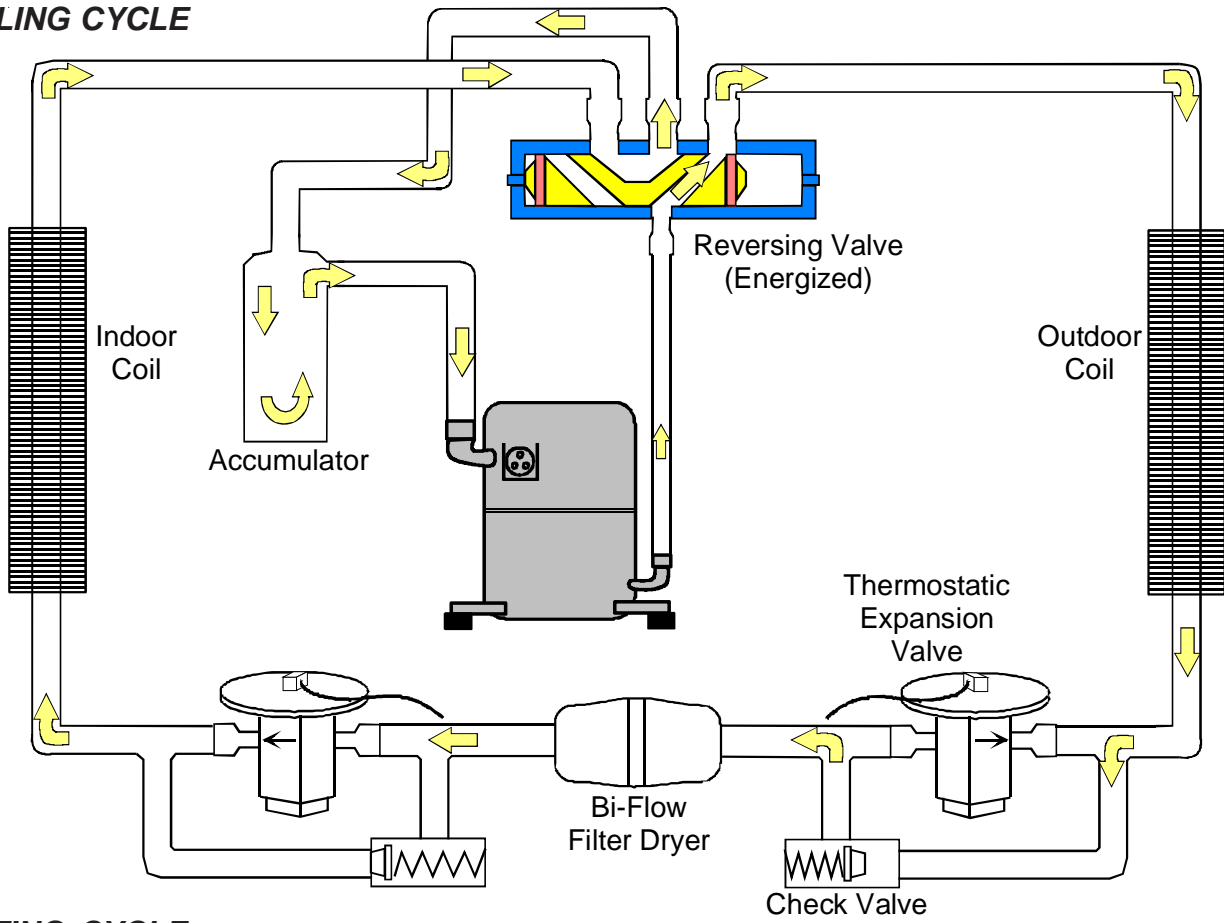

## HEATING CYCLE

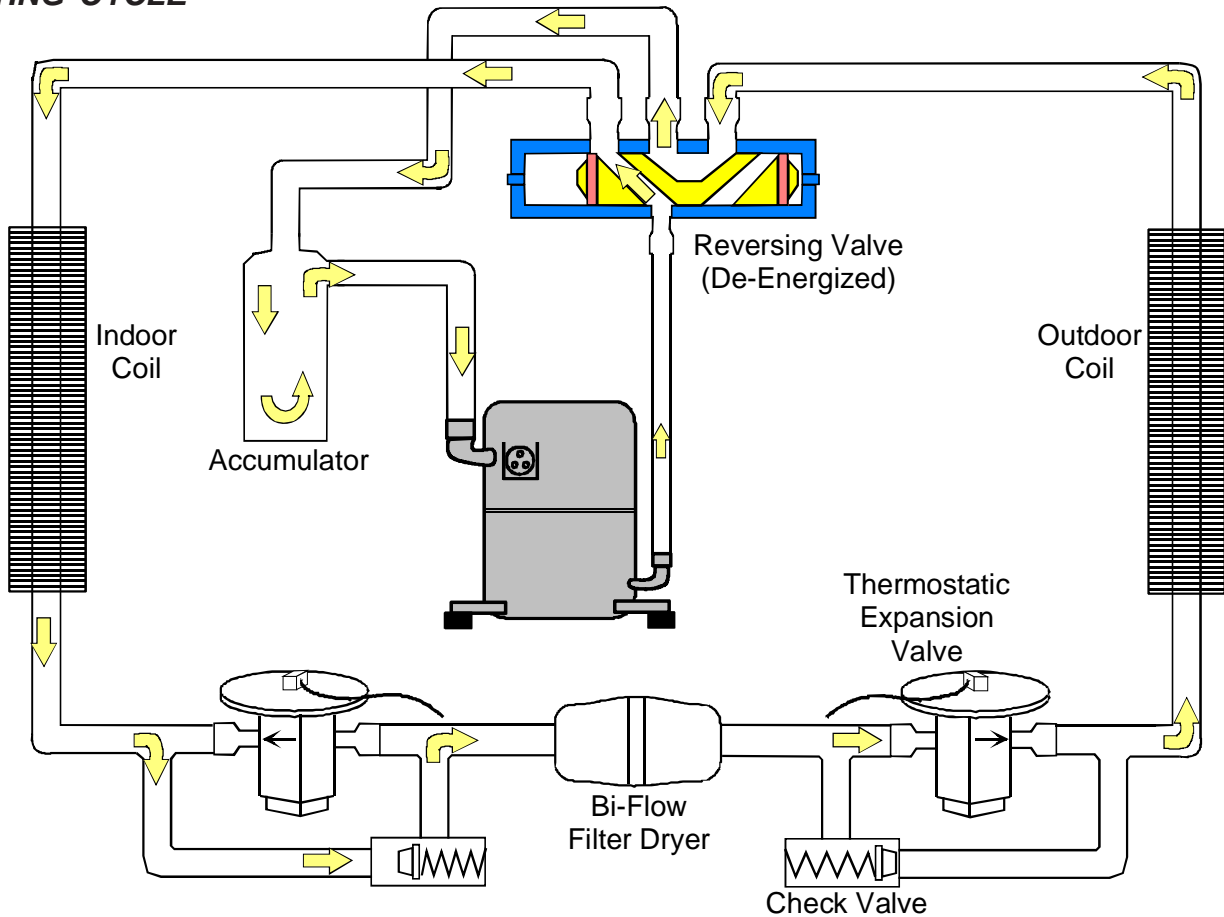



# SYSTEM OPERATION

**EXPANSION VALVE/CHECK VALVE ASSEMBLY  
IN COOLING OPERATION**

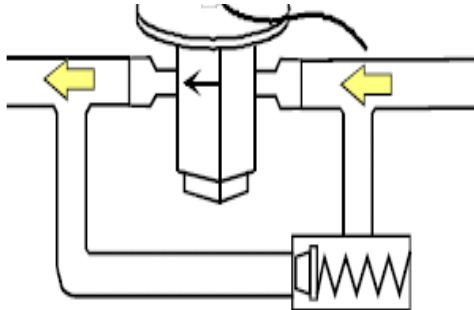

**EXPANSION VALVE/CHECK VALVE ASSEMBLY  
IN HEATING OPERATION**

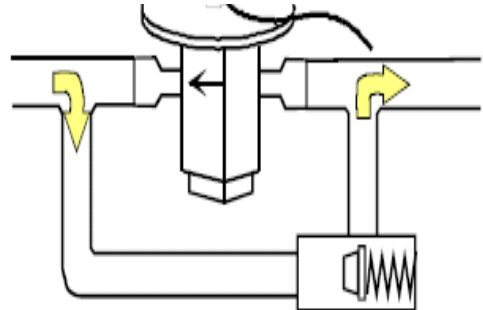

Most expansion valves used in current Amana® Brand Heat Pump products use an internally checked expansion valve. This type of expansion valve does not require an external check valve as shown above. However, the principle of operation is the same.

**RESTRICTOR ORIFICE ASSEMBLY  
IN COOLING OPERATION**

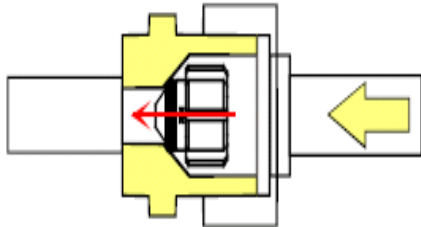

In the cooling mode, the orifice is pushed into its seat, forcing refrigerant to flow through the metered hole in the center of the orifice.

**RESTRICTOR ORIFICE ASSEMBLY  
IN HEATING OPERATION**

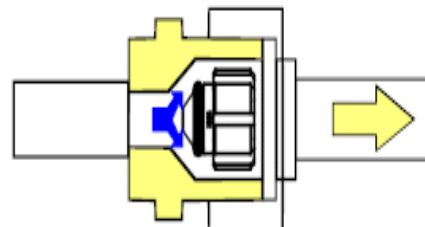

In the heating mode, the orifice moves back off its seat, allowing refrigerant to flow unmeasured around the outside of the orifice.

# SYSTEM OPERATION

## COOLING CYCLE - CONDENSING UNIT

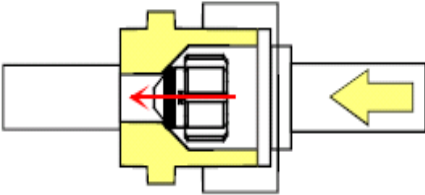
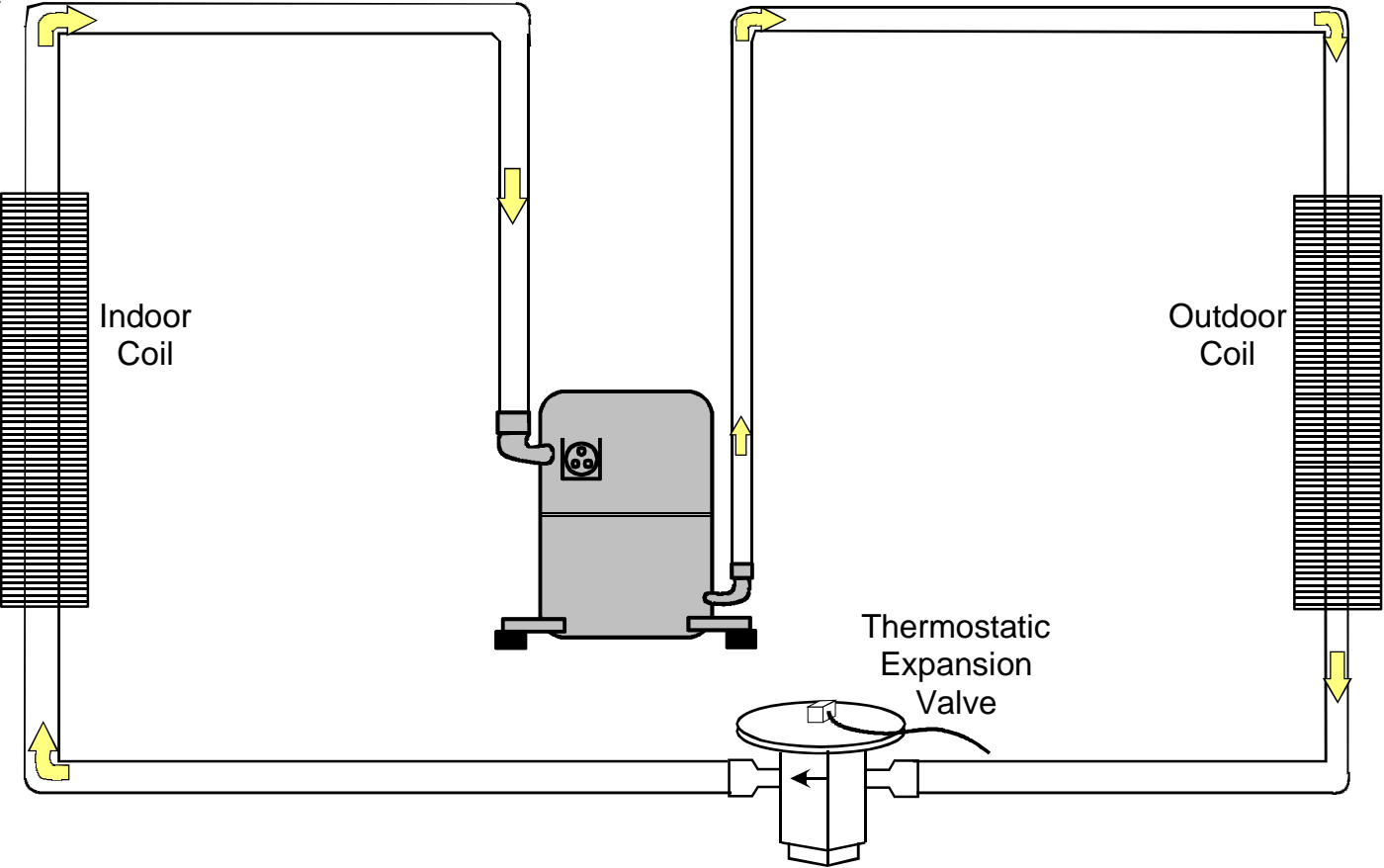

In the cooling mode, the orifice is pushed into its seat, forcing refrigerant to flow through the metered hole in the center of the orifice.

# SYSTEM OPERATION

## AFE18-60A CONTROL BOARD



### DESCRIPTION

The AFE18 control is designed for use in heat pump applications where the indoor coil is located above/downstream of a gas or fossil fuel furnace. It will operate with single and two stage heat pumps and single and two stage furnaces. The AFE18 control will turn the heat pump unit off when the furnace is turned on. An anti-short cycle feature is also incorporated which initiates a 3 minute timed off delay when the compressor goes off. On initial power up or loss and restoration of power, this 3 minute timed off delay will be initiated. The compressor won't be allowed to restart until the 3 minute off delay has expired. Also included is a 5 second de-bounce feature on the "Y, E, W1 and O" thermostat inputs. These thermostat inputs must be present for 5 seconds before the AFE18 control will respond to it.

An optional outdoor thermostat, OT18-60A, can be used with the AFE18 to switch from heat pump operation to furnace operation below a specific ambient temperature setting, i.e. break even temperature during heating. When used in this manner, the "Y" heat demand is switched to the "W1" input to the furnace by the outdoor thermostat and the furnace is used to satisfy the first stage "Y" heat demand. On some

controls, if the outdoor thermostat fails closed in this position during the heating season, it will turn on the furnace during the cooling season on a "Y" cooling demand. In this situation, the furnace produces heat and increases the indoor temperature thereby never satisfying the cooling demand. The furnace will continue to operate and can only be stopped by switching the thermostat to the off position or removing power to the unit and then replacing the outdoor thermostat. **When the AFE18 receives a "Y" and "O" input from the indoor thermostat**, it recognizes this as a cooling demand in the cooling mode. If the outdoor thermostat is stuck in the closed position switching the "Y" demand to the "W1" furnace input during the cooling mode as described above, the AFE18 won't allow the furnace to operate. The outdoor thermostat will have to be replaced to restore the unit to normal operation.

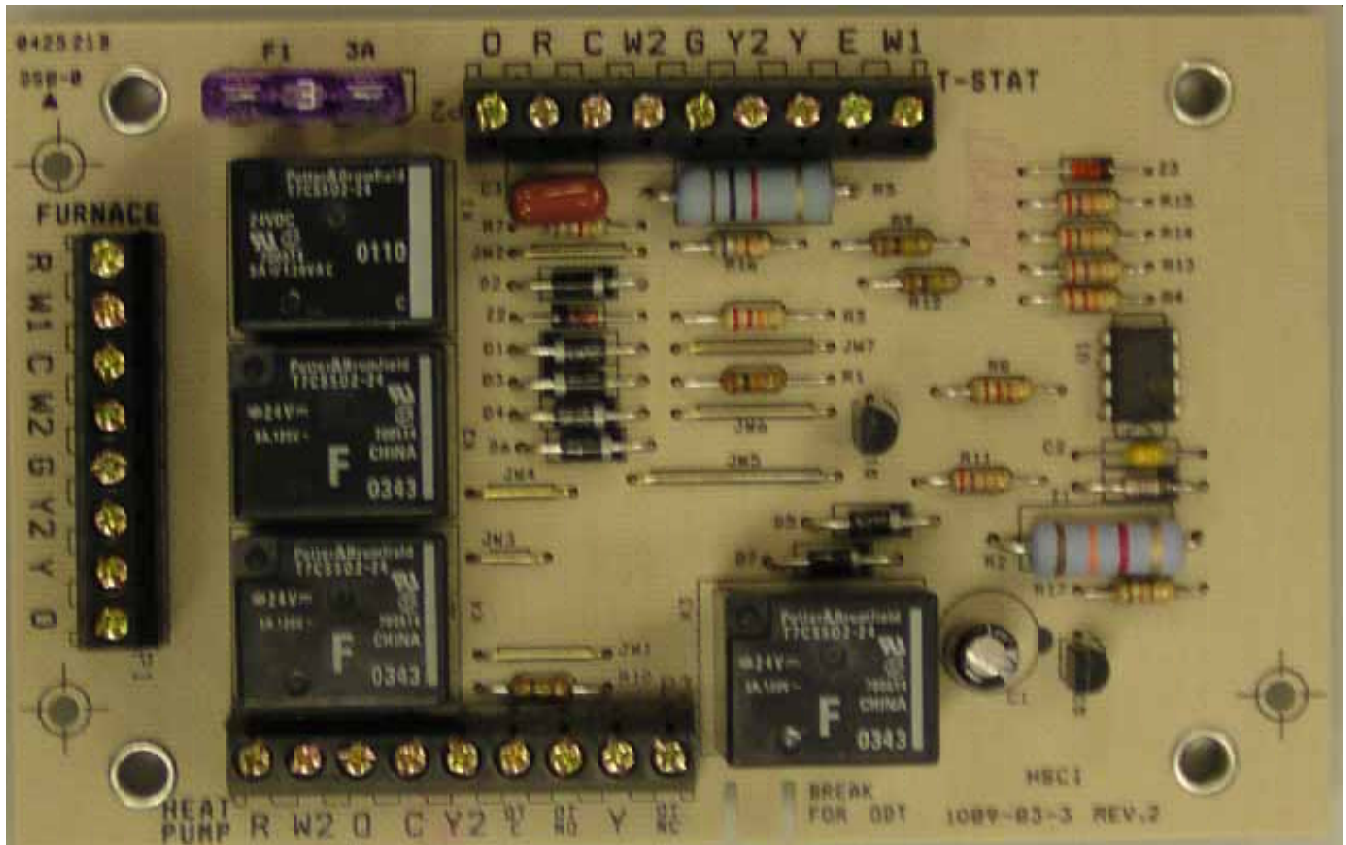
**⚠ WARNING**  
**HIGH VOLTAGE**  
Disconnect ALL power before servicing or installing this unit. Multiple power sources may be present. Failure to do so may cause property damage, personal injury or death.



# TROUBLESHOOTING CHART

## COOLING/HP ANALYSIS CHART

Complaint	No Cooling						Unsatisfactory Cooling/Heating						System Operating Pressures				Test Method Remedy	See Service Procedure Ref.			
	SYMPTOM	System will not start	Compressor will not start - fan runs	Comp. and Cond. Fan will not start	Evaporator fan will not start	Condenser fan will not start	Compressor runs - goes off on overload	Compressor cycles on overload	System runs continuously - little cooling/htg	Too cool and then too warm	Not cool enough on warm days	Certain areas too cool, others too warm	Compressor is noisy	System runs - blows cold air in heating	Unit will not terminate defrost	Unit will not defrost			Low suction pressure	Low head pressure	High suction pressure
Power Failure	●																			Test Voltage	S-1
Blown Fuse	●																			Inspect Fuse Size & Type	S-1
Unbalanced Power, 3PH		●																		Test Voltage	S-1
Loose Connection	●																			Inspect Connection - Tighten	S-2, S-3
Shorted or Broken Wires	●	●	●	●	●	●														Test Circuits With Ohmmeter	S-2, S-3
Open Fan Overload				●	●															Test Continuity of Overload	S-17A
Faulty Thermostat	●								●											Test Continuity of Thermostat & Wiring	S-3
Faulty Transformer	●		●																	Check Control Circuit with Voltmeter	S-4
Shorted or Open Capacitor		●		●	●	●	●													Test Capacitor	S-15
Internal Compressor Overload Open		●											◆							Test Continuity of Overload	S-17A
Shorted or Grounded Compressor		●				●														Test Motor Windings	S-17B
Compressor Stuck		●				●	●						◆							Use Test Cord	S-17D
Faulty Compressor Contactor			●		●	●														Test Continuity of Coil & Contacts	S-7, S-8
Faulty Fan Relay				●																Test Continuity of Coil And Contacts	S-7
Open Control Circuit				●																Test Control Circuit with Voltmeter	S-4
Low Voltage		●				●	●													Test Voltage	S-1
Faulty Evap. Fan Motor				●												●		◆		Repair or Replace	S-16
Shorted or Grounded Fan Motor				●															●	Test Motor Windings	S-16
Improper Cooling Anticipator						●		●												Check Resistance of Anticipator	S-3B
Shortage of Refrigerant						●	●						◆			●	●			Test For Leaks, Add Refrigerant	S-101,103
Restricted Liquid Line						●	●									●	●		●	Remove Restriction, Replace Restricted Part	S-112
Open Element or Limit on Elec. Heater								◆						◆						Test Heater Element and Controls	S-26, S-27
Dirty Air Filter								●	●	●						●			◆	Inspect Filter-Clean or Replace	
Dirty Indoor Coil								●	●	●						●			◆	Inspect Coil - Clean	
Not enough air across Indoor Coil								●	●	●						●			◆	Check Blower Speed, Duct Static Press, Filter	S-200
Too much air across Indoor Coil																	◆	●	Reduce Blower Speed	S-200	
Overcharge of Refrigerant						●	●										●	●	●	Recover Part of Charge	S-113
Dirty Outdoor Coil						●	●		●							◆			●	Inspect Coil - Clean	
Noncondensibles								●		●									●	Recover Charge, Evacuate, Recharge	S-114
Recirculation of Condensing Air						●			●										●	Remove Obstruction to Air Flow	
Infiltration of Outdoor Air								●	●	●										Check Windows, Doors, Vent Fans, Etc.	
Improperly Located Thermostat						●			●											Relocate Thermostat	
Air Flow Unbalanced								●	●	●										Readjust Air Volume Dampers	
System Undersized								●	●											Refigure Cooling Load	
Broken Internal Parts													●	◆						Replace Compressor	S-115
Broken Valves								●	●	●							●	●		Test Compressor Efficiency	S-104
Inefficient Compressor								●						◆				●	●	Test Compressor Efficiency	S-104
Wrong Type Expansion Valve						●	●	●	●							●	●		◆	Replace Valve	S-110
Expansion Device Restricted						●	●	●	●							●	●			Remove Restriction or Replace Expansion Device	S-110
Oversized Expansion Valve								●											●	Replace Valve	
Undersized Expansion Valve						●	●	●	●							●				Replace Valve	
Expansion Valve Bulb Loose																		●		Tighten Bulb Bracket	S-105
Inoperative Expansion Valve						●		●								●				Check Valve Operation	S-110
Loose Hold-down Bolts													●							Tighten Bolts	
Faulty Reversing Valve																			◆	Replace Valve or Solenoid	S-21, 122
Faulty Defrost Control																			◆	Test Control	S-24
Faulty Defrost Thermostat																			◆	Test Defrost Thermostat	S-25
Flowrator Not Seating Properly								●											●	Check Flowrator & Seat or Replace Flowrator	S-111

● Cooling or Heating Cycle (Heat Pump)

◆ Heating Cycle Only (Heat Pump)

# SERVICING

## Table of Contents

S-1	Checking Voltage .....	22	S-40	MBR & AR*F Electronic Blower Time Delay ..	36
S-2	Checking Wiring .....	22	S-41	MBE & AEPT with Single Speed Air Conditioning and Heat Pump .....	38
S-3	Checking Thermostat, Wiring & Anticipator ..	22	S-60	Electric Heater (optional item) .....	40
S-3A	Thermostat & Wiring .....	23	S-61A	Checking Heater Limit Control(S) .....	41
S-3B	Cooling Anticipator .....	23	S-61B	Checking Heater Fuse Line .....	41
S-3C	Heating Anticipator .....	23	S-62	Checking Heater Elements .....	42
S-3D	Checking Encoded Thermostats .....	23	S-100	Refrigeration Repair Practice .....	42
S-4	Checking Transformer & Control Circuit .....	24	S-101	Leak Testing .....	42
S-5	Checking Cycle Protector .....	24	S-102	Evacuation .....	42
S-6	Checking Time Delay Relay .....	24	S-103	Charging .....	43
S-7	Checking Contactor and/or Relays .....	25	S-104	Checking Compressor Efficiency .....	44
S-8	Checking Contactor Contacts .....	25	S-105B	Thermostatic Expansion Valve .....	44
S-9	Checking Fan Relay Contact .....	25	S-106	Overfeeding .....	45
S-10	Copeland Comfort™ Alert Diagnostics .....	26	S-107	Underfeeding .....	45
S-12	Checking High Pressure Control .....	28	S-108	Superheat .....	45
S-13	Checking Low Pressure Control .....	28	S-109	Checking Subcooling .....	46
S-15	Checking Capacitor .....	28	S-110	Checking Expansion Valve Operation .....	46
S-15A	Resistance Check .....	29	S-111	Fixed Orifice Restriction Devices .....	47
S-15B	Capacitance Check .....	29	S-112	Checking Restricted Liquid Line .....	47
S-16A	Checking Fan & Blower Motor Windings (PSC Motors) .....	29	S-113	Refrigerant Overcharge .....	47
S-16B	Checking Fan & Blower Motor (ECM Motors)	30	S-114	Non-condensables .....	47
S-16C	Checking ECM Motor Windings .....	33	S-115	Compressor Burnout .....	48
S-16D	ECM CFM Adjustments .....	33	S-120	Refrigerant Piping .....	48
S-17	Checking Compressor Windings .....	34	S-122	Replacing Reversing Valve .....	50
S-17A	Resistance Test .....	34	S-202	Duct Static Pressure & Static Pressure Drop Across Coils .....	51
S-17B	Ground Test .....	35	S-203	Air Handler External Static .....	51
S-17D	Operation Test .....	35	S-204	Coil Static Pressure Drop .....	51
S-18	Testing Crankcase Heater (optional item) .....	36			
S-21	Checking Reversing Valve Solenoid .....	36			

 <b>WARNING</b>	<b>HIGH VOLTAGE!</b> DISCONNECT ALL POWER BEFORE SERVICING OR INSTALLING THIS UNIT. MULTIPLE POWER SOURCES MAY BE PRESENT. FAILURE TO DO SO MAY CAUSE PROPERTY DAMAGE, PERSONAL INJURY OR DEATH.	
--	---	---

# SERVICING

## S-1 CHECKING VOLTAGE

1. Remove outer case, control panel cover, etc., from unit being tested.

With power ON:



**WARNING**  
Line Voltage now present.

2. Using a voltmeter, measure the voltage across terminals L1 and L2 of the contactor for the condensing unit or at the field connections for the air handler or heaters.
3. No reading - indicates open wiring, open fuse(s) no power or etc., from unit to fused disconnect service. Repair as needed.
4. With ample voltage at line voltage connectors, energize the unit.
5. Measure the voltage with the unit starting and operating, and determine the unit Locked Rotor Voltage. **NOTE:** If checking heaters, be sure all heating elements are energized.

**Locked Rotor Voltage** is the actual voltage available at the compressor during starting, locked rotor, or a stalled condition. Measured voltage should be above minimum listed in chart below.

To measure Locked Rotor Voltage attach a voltmeter to the run "R" and common "C" terminals of the compressor, or to the T<sub>1</sub> and T<sub>2</sub> terminals of the contactor. Start the unit and allow the compressor to run for several seconds, then shut down the unit. Immediately attempt to restart the unit while measuring the Locked Rotor Voltage.

6. Lock rotor voltage should read within the voltage tabulation as shown. If the voltage falls below the minimum voltage, check the line wire size. Long runs of undersized wire can cause low voltage. If wire size is adequate, notify the local power company in regard to either low or high voltage.

REMOTE CONDENSING UNITS BLOWER COILS		
VOLTAGE	MIN.	MAX.
208/230	198	253
115	104	127

**NOTE:** When operating electric heaters on voltages other than 240 volts, refer to the System Operation section on electric heaters to calculate temperature rise and air flow. Low voltage may cause insufficient heating.

## S-2 CHECKING WIRING



**WARNING**  
**HIGH VOLTAGE**  
Disconnect ALL power before servicing or installing this unit. Multiple power sources may be present. Failure to do so may cause property damage, personal injury or death.



1. Check wiring visually for signs of overheating, damaged insulation and loose connections.
2. Use an ohmmeter to check continuity of any suspected open wires.
3. If any wires must be replaced, replace with comparable gauge and insulation thickness.

## S-3 CHECKING THERMOSTAT, WIRING, AND ANTICIPATOR

THERMOSTAT WIRE SIZING CHART	
LENGTH OF RUN	MIN. COPPER WIRE GAUGE (AWG)
25 feet	18
50 feet	16
75 feet	14
100 feet	14
125 feet	12
150 feet	12

### S-3A THERMOSTAT AND WIRING



**WARNING**  
Line Voltage now present.

With power ON, thermostat calling for cooling

1. Use a voltmeter to check for 24 volts at thermostat wires C and Y in the condensing unit control panel.
2. No voltage indicates trouble in the thermostat, wiring or external transformer source.
3. Check the continuity of the thermostat and wiring. Repair or replace as necessary.

#### *Indoor Blower Motor*

With power ON:



**WARNING**  
Line Voltage now present.

1. Set fan selector switch at thermostat to "ON" position.
2. With voltmeter, check for 24 volts at wires C and G.
3. No voltage indicates the trouble is in the thermostat or wiring.



# SERVICING

4. Check the continuity of the thermostat and wiring. Repair or replace as necessary.

## Resistance Heaters

1. Set room thermostat to a higher setting than room temperature so both stages call for heat.
2. With voltmeter, check for 24 volts at each heater relay. Note: BBA/BBC heater relays are DC voltage.
3. No voltage indicates the trouble is in the thermostat or wiring.
4. Check the continuity of the thermostat and wiring. Repair or replace as necessary.

**NOTE:** Consideration must be given to how the heaters are wired (O.D.T. and etc.). Also safety devices must be checked for continuity.

## S-3B COOLING ANTICIPATOR

The cooling anticipator is a small heater (resistor) in the thermostat. During the "off" cycle, it heats the bimetal

element helping the thermostat call for the next cooling cycle. This prevents the room temperature from rising too high before the system is restarted. A properly sized anticipator should maintain room temperature within 1 1/2 to 2 degree range.

The anticipator is supplied in the thermostat and is not to be replaced. If the anticipator should fail for any reason, the thermostat must be changed.

## S-3C HEATING ANTICIPATOR

The heating anticipator is a wire wound adjustable heater which is energized during the "ON" cycle to help prevent overheating of the conditioned space.

The anticipator is a part of the thermostat and if it should fail for any reason, the thermostat must be replaced. See the following tables for recommended heater anticipator setting in accordance to the number of electric heaters installed.

## S-3D TROUBLESHOOTING ENCODED TWO STAGE COOLING THERMOSTATS OPTIONS

### Troubleshooting Encoded Two Stage Cooling Thermostats Options

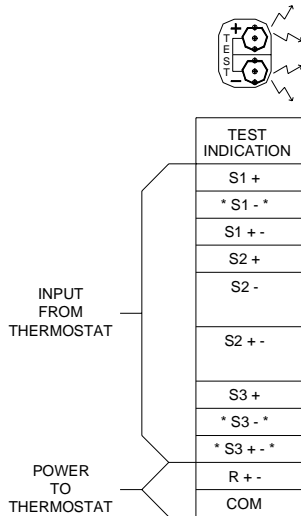

TEST INDICATION	FUNCTION	SIGNAL OUT	SIGNAL FAN	
S1 +	LOW SPEED COOL	YCON +	Y1	
* S1 - *	* LO SPEED COOL *	* YCON - *	* Y / Y2 HI *	* ERROR CONDITION ( DIODE ON THERMOSTAT BACKWARDS )
S1 +-	HI SPEED COOL	YCON +-	Y / Y2	
S2 +	LO SPEED HEAT	W1 HEATER	W / W1	SEE NOTE 3
S2 -	O	ED - ( FUTURE USE )	O	
S2 +-	LO SPEED HEAT HI SPEED HEAT	W1 HEATER W2 HEATER	W / W1 EM / W2	SEE NOTE 3
S3 +	G	NONE	G	
* S3 - *	N/A	N/A	N/A	* ERROR CONDITION ( S3 CAN ONLY READ + )
* S3 +- *	N/A	N/A	N/A	* ERROR CONDITION ( S3 CAN ONLY READ + )
R +-	24 VAC	R TO T'STAT	R	
COM	GND	COM TO T'STAT	C1 , C2	

- NOTES:
- 1.) THE TEST SPADE CAN BE CONNECTED TO ANY OTHER TEST SPADE ON EITHER BOARD.
  - 2.) THE + LED WILL BE RED AND WILL LIGHT TO INDICATE + HALF CYCLES. THE - LED WILL BE GREEN AND WILL LIGHT TO INDICATE - HALF CYCLES. BOTH RED AND GREEN ILLUMINATED WILL INDICATE FULL CYCLES DENOTED BY +- .
  - 3.) SIGNAL OUT CONDITION FOR W1 , W2 HEATER WILL BE AFFECTED BY OT1 PJ4 AND OT2 PJ2 JUMPERS AND OUTDOOR THERMOSTATS ATTACHED. THE TABLE ABOVE ASSUMES OT1 PJ4 IS REMOVED AND OT2 PJ2 IS MADE WITH NO OUTDOOR THERMOSTATS ATTACHED.

The chart above provides troubleshooting for either version of the encoded thermostat option. This provides diagnostic information for the GMC CHET18-60 or a conventional two cool / two stage heat thermostat with IN4005 diodes added as called out in the above section.

A test lead or jumper wire can be added from the test terminal to any terminal on the B13682-74 or B13682-71 variable speed terminal board and provide information through the use of the LED lights on the B13682-71 VSTB control. Using this chart, a technician can determine if the proper input signal is being received by the encoded VSTB control and diagnose any problems that may be relayed to the output response of the B13682-74 VSTM control.

# SERVICING

## S-4 CHECKING TRANSFORMER AND CONTROL CIRCUIT

**WARNING**

**HIGH VOLTAGE**  
Disconnect ALL power before servicing or installing this unit. Multiple power sources may be present. Failure to do so may cause property damage, personal injury or death.



A step-down transformer (208/240 volt primary to 24 volt secondary) is provided with each indoor unit. This allows ample capacity for use with resistance heaters. The outdoor sections do not contain a transformer.

**WARNING**

Disconnect ALL power before servicing.

1. Remove control panel cover, or etc., to gain access to transformer.

With power ON:

**WARNING**

Line Voltage now present.

2. Using a voltmeter, check voltage across secondary voltage side of transformer (R to C).
3. No voltage indicates faulty transformer, bad wiring, or bad splices.
4. Check transformer primary voltage at incoming line voltage connections and/or splices.
5. If line voltage available at primary voltage side of transformer and wiring and splices good, transformer is inoperative. Replace.

## S-5 CHECKING CYCLE PROTECTOR

Some models feature a solid state, delay-on make after break time delay relay installed in the low voltage circuit. This control is used to prevent short cycling of the compressor under certain operating conditions.

The component is normally closed ( $R_1$  to  $Y_1$ ). A power interruption will break circuit ( $R_1$  to  $Y_1$ ) for approximately three minutes before resetting.

1. Remove wire from  $Y_1$  terminal.
2. Wait for approximately four (4) minutes if machine was running.

With power ON:

**WARNING**

Line Voltage now present.

1. Apply 24 VAC to terminals  $R_1$  and  $R_2$ .
2. Should read 24 VAC at terminals  $Y_1$  and  $Y_2$ .
3. Remove 24 VAC at terminals  $R_1$  and  $R_2$ .
4. Should read 0 VAC at  $Y_1$  and  $Y_2$ .
5. Reapply 24 VAC to  $R_1$  and  $R_2$  - within approximately three (3) to four (4) minutes should read 24 VAC at  $Y_1$  and  $Y_2$ .

If not as above - replace relay.

## S-6 CHECKING TIME DELAY RELAY

Time delay relays are used in some of the blower cabinets to improve efficiency by delaying the blower off time. Time delays are also used in electric heaters to sequence in multiple electric heaters.

**WARNING**

Disconnect ALL power before servicing.

1. Tag and disconnect all wires from male spade connections of relay.
2. Using an ohmmeter, measure the resistance across terminals H1 and H2. Should read approximately 150 ohms.
3. Using an ohmmeter, check for continuity across terminals 3 and 1, and 4 and 5.
4. Apply 24 volts to terminals H1 and H2. Check for continuity across other terminals - should test continuous. If not as above - replace.

**NOTE:** The time delay for the contacts to make will be approximately 20 to 50 seconds and to open after the coil is de-energized is approximately 40 to 90 seconds.

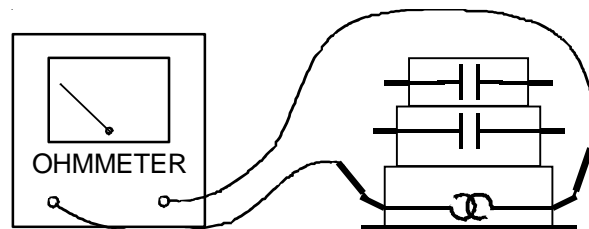

TESTING COIL CIRCUIT



# SERVICING

## S-7 CHECKING CONTACTOR AND/OR RELAYS

**WARNING**  
**HIGH VOLTAGE!**  
 Disconnect ALL power before servicing or installing. Multiple power sources may be present. Failure to do so may cause property damage, personal injury or death.

The compressor contactor and other relay holding coils are wired into the low or line voltage circuits. When the control circuit is energized, the coil pulls in the normally open contacts or opens the normally closed contacts. When the coil is de-energized, springs return the contacts to their normal position.

**NOTE:** Most single phase contactors break only one side of the line (L1), leaving 115 volts to ground present at most internal components.

1. Remove the leads from the holding coil.
2. Using an ohmmeter, test across the coil terminals.

If the coil does not test continuous, replace the relay or contactor.

## S-8 CHECKING CONTACTOR CONTACTS

**WARNING**  
 DISCONNECT ELECTRICAL POWER SUPPLY.

**Disconnect Electrical Power Supply:**

1. Disconnect the wire leads from the terminal (T) side of the contactor.
2. With power ON, energize the contactor.

**WARNING**  
 Line Voltage now present.

3. Using a voltmeter, test across terminals.
  - A. L2 - T1 - No voltage indicates CC1 contacts open.
 If a no voltage reading is obtained - replace the contactor.

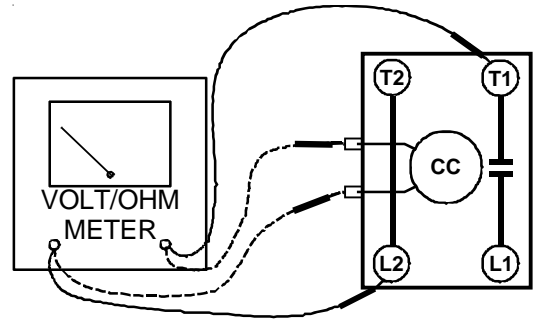

---- Ohmmeter for testing holding coil  
 — Voltmeter for testing contacts

**TESTING COMPRESSOR CONTACTOR**

## S-9 CHECKING FAN RELAY CONTACTS

**WARNING**  
**HIGH VOLTAGE**  
 Disconnect ALL power before servicing or installing this unit. Multiple power sources may be present. Failure to do so may cause property damage, personal injury or death.

1. Disconnect wires leads from terminals 2 and 4 of Fan Relay Cooling and 2 and 4, 5 and 6 of Fan Relay Heating.
2. Using an ohmmeter, test between 2 and 4 - should read open. Test between 5 and 6 - should read continuous.
3. With power ON, energize the relays.

**WARNING**  
 Line Voltage now present.

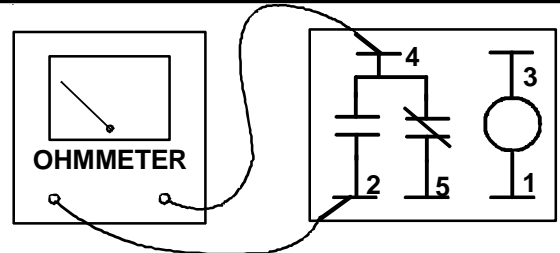

**TESTING FAN RELAY**

4. Using an ohmmeter, test between 2 and 4 - should read continuous. Test between 5 and 6 - should read open.
5. If not as above, replace the relay.

# SERVICING

## S-10 COPELAND COMFORT ALERT™

### DIAGNOSTICS

Applies to ASC13 & ASH13

## WARNING

**HIGH VOLTAGE**  
Disconnect ALL power before servicing or installing this unit. Multiple power sources may be present. Failure to do so may cause property damage, personal injury or death.

Comfort Alert™ is self-contained with no required external sensors and is designed to install directly into the electrical box of any residential condensing unit that has a Copeland Scroll™ compressor inside.

Once attached, Comfort Alert™ provides around-the-clock monitoring for common electrical problems, compressor defects and broad system faults. If a glitch is detected, an LED indicator flashes the proper alert codes to help you quickly pinpoint the problem. See *Diagnostic Table* on following page.)

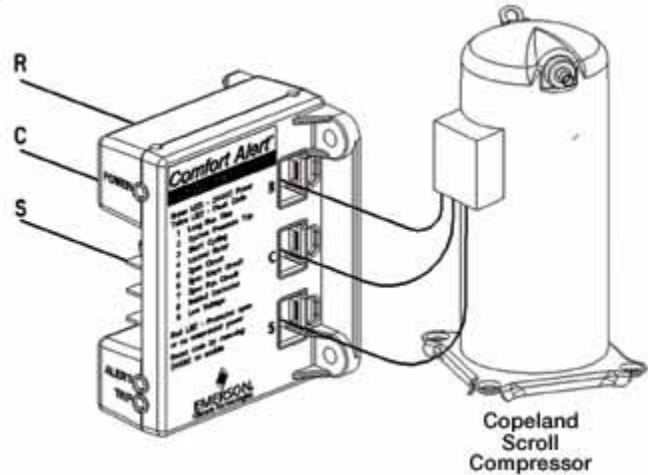
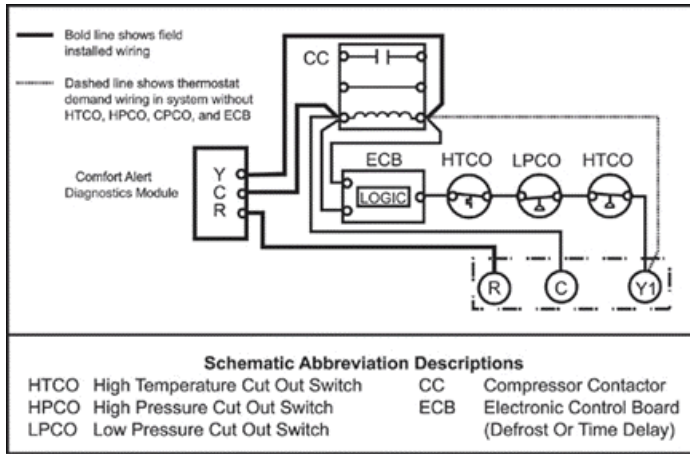

# SERVICING

## DIAGNOSTICS TABLE

Status LED	Status LED Description	Status LED Troubleshooting Information
Green "POWER"	Module has power	Supply voltage is present at module terminals
Red "TRIP"	Thermostat demand signal Y1 is present, but the compressor is not running	<ol style="list-style-type: none"> <li>1. Compressor protector is open</li> <li>2. Outdoor unit power disconnect is open</li> <li>3. Compressor circuit breaker or fuse(s) is open</li> <li>4. Broken wire or connector is not making contact</li> <li>5. Low pressure switch open if present in system</li> <li>6. Compressor contactor has failed open</li> </ol>
Yellow "ALERT" Flash Code 1	Long Run Time Compressor is running extremely long run cycles	<ol style="list-style-type: none"> <li>1. Low refrigerant charge</li> <li>2. Evaporator blower is not running</li> <li>3. Evaporator coil is frozen</li> <li>4. Faulty metering device</li> <li>5. Condenser coil is dirty</li> <li>6. Liquid line restriction (filter drier blocked if present in system)</li> <li>7. Thermostat is malfunctioning</li> </ol>
Yellow "ALERT" Flash Code 2	System Pressure Trip Discharge or suction pressure out of limits or compressor overloaded	<ol style="list-style-type: none"> <li>1. High head pressure</li> <li>2. Condenser coil poor air circulation (dirty, blocked, damaged)</li> <li>3. Condenser fan is not running</li> <li>4. Return air duct has substantial leakage</li> <li>5. If low pressure switch present in system, check Flash Code 1 information</li> </ol>
Yellow "ALERT" Flash Code 3	Short Cycling Compressor is running only briefly	<ol style="list-style-type: none"> <li>1. Thermostat demand signal is intermittent</li> <li>2. Time delay relay or control board defective</li> <li>3. If high pressure switch present go to Flash Code 2 information</li> <li>4. If low pressure switch present go to Flash Code 1 information</li> </ol>
Yellow "ALERT" Flash Code 4	Locked Rotor	<ol style="list-style-type: none"> <li>1. Run capacitor has failed</li> <li>2. Low line voltage (contact utility if voltage at disconnect is low)</li> <li>3. Excessive liquid refrigerant in compressor</li> <li>4. Compressor bearings are seized</li> </ol>
Yellow "ALERT" Flash Code 5	Open Circuit	<ol style="list-style-type: none"> <li>1. Outdoor unit power disconnect is open</li> <li>2. Compressor circuit breaker or fuse(s) is open</li> <li>3. Compressor contactor has failed open</li> <li>4. High pressure switch is open and requires manual reset</li> <li>5. Open circuit in compressor supply wiring or connections</li> <li>6. Unusually long compressor protector reset time due to extreme ambient temperature</li> <li>7. Compressor windings are damaged</li> </ol>
Yellow "ALERT" Flash Code 6	Open Start Circuit Current only in run circuit	<ol style="list-style-type: none"> <li>1. Run capacitor has failed</li> <li>2. Open circuit in compressor start wiring or connections</li> <li>3. Compressor start winding is damaged</li> </ol>
Yellow "ALERT" Flash Code 7	Open Run Circuit Current only in start circuit	<ol style="list-style-type: none"> <li>1. Open circuit in compressor run wiring or connections</li> <li>2. Compressor run winding is damaged</li> </ol>
Yellow "ALERT" Flash Code 8	Welded Contactor Compressor always runs	<ol style="list-style-type: none"> <li>1. Compressor contactor has failed closed</li> <li>2. Thermostat demand signal not connected to module</li> </ol>
Yellow "ALERT" Flash Code 9	Low Voltage Control circuit < 17VAC	<ol style="list-style-type: none"> <li>1. Control circuit transformer is overloaded</li> <li>2. Low line voltage (contact utility if voltage at disconnect is low)</li> </ol>

- Flash Code number corresponds to a number of LED flashes, followed by a pause and then repeated
- TRIP and ALERT LEDs flashing at same time means control circuit voltage is too low for operation.
- Reset ALERT Flash code by removing 24VAC power from module
- Last ALERT Flash code is displayed for 1 minute after module is powered on.

# SERVICING

## S-12 CHECKING HIGH PRESSURE CONTROL

**WARNING**

**HIGH VOLTAGE**  
Disconnect ALL power before servicing or installing this unit. Multiple power sources may be present. Failure to do so may cause property damage, personal injury or death.



The high pressure control capillary senses the pressure in the compressor discharge line. If abnormally high condensing pressures develop, the contacts of the control open, breaking the control circuit before the compressor motor overloads. This control is automatically reset.

1. Using an ohmmeter, check across terminals of high pressure control, with wire removed. If not continuous, the contacts are open.
3. Attach a gauge to the dill valve port on the base valve.

With power ON:

**WARNING**

Line Voltage now present.

4. Start the system and place a piece of cardboard in front of the condenser coil, raising the condensing pressure.
5. Check pressure at which the high pressure control cuts-out.

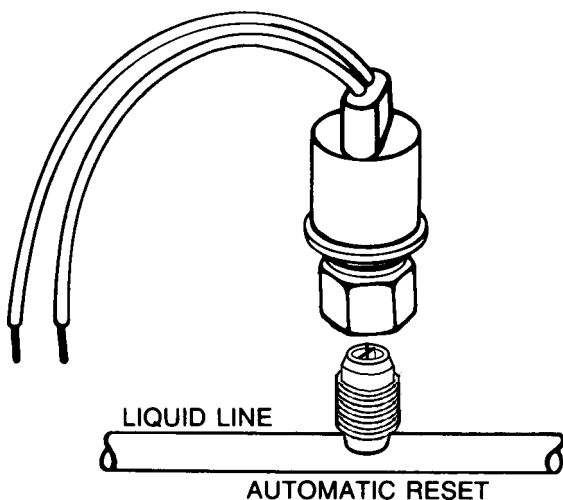

If it cuts-out at 610 PSIG  $\pm$  10 PSIG, it is operating normally (See causes for high head pressure in Service Problem Analysis Guide). If it cuts out below this pressure range, replace the control.

## S-13 CHECKING LOW PRESSURE CONTROL

The low pressure control senses the pressure in the suction line and will open its contacts on a drop in pressure. The low pressure control will automatically reset itself with a rise in pressure.

The low pressure control is designed to cut-out (open) at approximately 50 PSIG. It will automatically cut-in (close) at approximately 85 PSIG.

Test for continuity using a VOM and if not as above, replace the control.

## S-15 CHECKING CAPACITOR

### CAPACITOR, RUN

A run capacitor is wired across the auxiliary and main windings of a single phase permanent split capacitor motor. The capacitors primary function is to reduce the line current while greatly improving the torque characteristics of a motor. This is accomplished by using the 90° phase relationship between the capacitor current and voltage in conjunction with the motor windings, so that the motor will give two phase operation when connected to a single phase circuit. The capacitor also reduces the line current to the motor by improving the power factor.

The line side of this capacitor is marked with "COM" and is wired to the line side of the circuit.

### CAPACITOR, START

#### SCROLL COMPRESSOR MODELS

In most cases hard start components are not required on Scroll compressor equipped units due to a non-replaceable check valve located in the discharge line of the compressor. However, in installations that encounter low lock rotor voltage, a hard start kit can improve starting characteristics and reduce light dimming within the home. Only hard start kits approved by Amana® or Copeland should be used. "Kick Start" and/or "Super Boost" kits are not approved start assist devices.

The discharge check valve closes off high side pressure to the compressor after shut down allowing equalization through the scroll flanks. Equalization requires only about ½ second.

To prevent the compressor from short cycling, a Time Delay Relay (Cycle Protector) has been added to the low voltage circuit.

### RELAY, START

A potential or voltage type relay is used to take the start capacitor out of the circuit once the motor comes up to speed. This type of relay is position sensitive. The normally closed contacts are wired in series with the start capacitor and the relay holding coil is wired parallel with the start winding. As the motor starts and comes up to speed, the increase in voltage across the start winding will energize the start relay holding coil and open the contacts to the start capacitor.

Two quick ways to test a capacitor are a resistance and a capacitance check.

# SERVICING

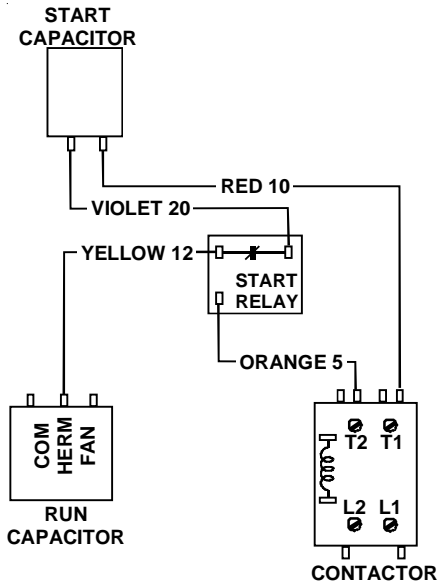

HARD START KIT WIRING

- B. Shorted - indicator swings to zero and stops there - replace.
- C. Open - no reading - replace. (Start capacitor would read resistor resistance.)

## S-15B CAPACITANCE CHECK

Using a hookup as shown below, take the amperage and voltage readings and use them in the formula:

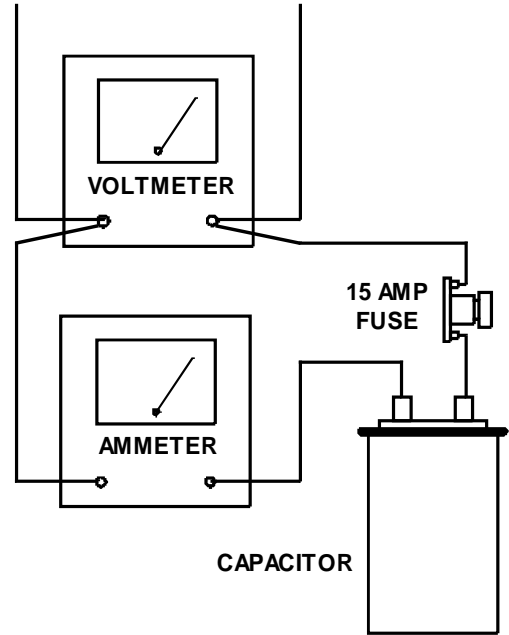

TESTING CAPACITANCE

## S-15A RESISTANCE CHECK

**WARNING**

**HIGH VOLTAGE**  
Disconnect ALL power before servicing or installing this unit. Multiple power sources may be present. Failure to do so may cause property damage, personal injury or death.

1. Discharge capacitor and remove wire leads.

**WARNING**

Discharge capacitor through a 20 to 30 OHM resistor before handling.

**WARNING**

Discharge capacitor through a 20 to 30 OHM resistor before handling.

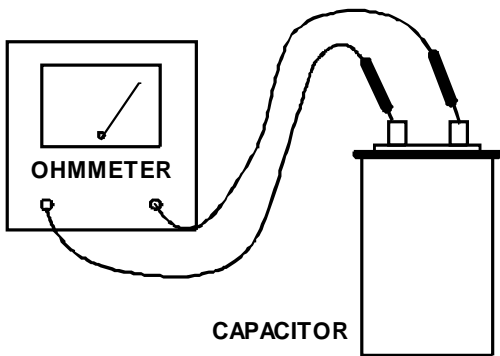

TESTING CAPACITOR RESISTANCE

$$\text{Capacitance (MFD)} = \frac{2650 \times \text{Amperage}}{\text{Voltage}}$$

## S-16A CHECKING FAN AND BLOWER MOTOR WINDINGS (PSC MOTORS)

The auto reset fan motor overload is designed to protect the motor against high temperature and high amperage conditions by breaking the common circuit within the motor, similar to the compressor internal overload. However, heat generated within the motor is faster to dissipate than the compressor, allow at least 45 minutes for the overload to reset, then retest.

2. Set an ohmmeter on its highest ohm scale and connect the leads to the capacitor -

A. Good Condition - indicator swings to zero and slowly returns to infinity. (Start capacitor with bleed resistor will not return to infinity. It will still read the resistance of the resistor).

# SERVICING



**WARNING**  
**HIGH VOLTAGE**  
 Disconnect ALL power before servicing or installing this unit. Multiple power sources may be present. Failure to do so may cause property damage, personal injury or death.

1. Remove the motor leads from its respective connection points and capacitor (if applicable).
2. Check the continuity between each of the motor leads.
3. Touch one probe of the ohmmeter to the motor frame (ground) and the other probe in turn to each lead.

If the windings do not test continuous or a reading is obtained from lead to ground, replace the motor.

## S-16B CHECKING FAN AND BLOWER MOTOR (ECM MOTORS)

An ECM is an *Electronically Commutated Motor* which offers many significant advantages over PSC motors. The ECM has near zero rotor loss, synchronous machine operation, variable speed, low noise, and programmable air flow. Because of the sophisticated electronics within the ECM motor, some technicians are intimidated by the ECM motor; however, these fears are unfounded. GE offers two ECM motor testers, and with a VOM meter, one can easily perform basic troubleshooting on ECM motors. An ECM motor requires power (line voltage) and a signal (24 volts) to operate. The ECM motor stator contains permanent magnet. As a result, the shaft feels "rough" when turned by hand. This is a characteristic of the motor, not an indication of defective bearings.



**WARNING**  
 Line Voltage now present.

1. Disconnect the 5-pin connector from the motor.
2. Using a volt meter, check for line voltage at terminals #4 & #5 at the power connector. If no voltage is present:
3. Check the unit for incoming power See section S-1.
4. Check the control board, See section S-40.
5. If line voltage is present, reinsert the 5-pin connector and remove the 16-pin connector.

6. Check for signal (24 volts) at the transformer.
7. Check for signal (24 volts) from the thermostat to the "G" terminal at the 16-pin connector.
8. Using an ohmmeter, check for continuity from the #1 & #3 (common pins) to the transformer neutral or "C" thermostat terminal. If you do not have continuity, the motor may function erratically. Trace the common circuits, locate and repair the open neutral.
9. Set the thermostat to "Fan-On". Using a voltmeter, check for 24 volts between pin # 15 (G) and common.
10. Disconnect power to compressor. Set thermostat to call for cooling. Using a voltmeter, check for 24 volts at pin # 6 and/or #14.
11. Set the thermostat to a call for heating. Using a voltmeter, check for 24 volts at pin #2 and/or #11.

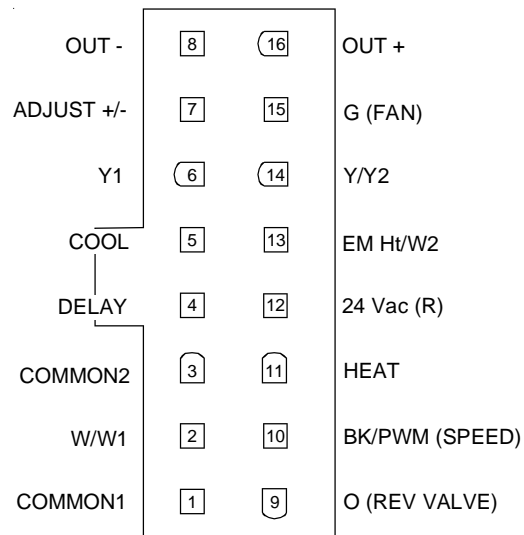
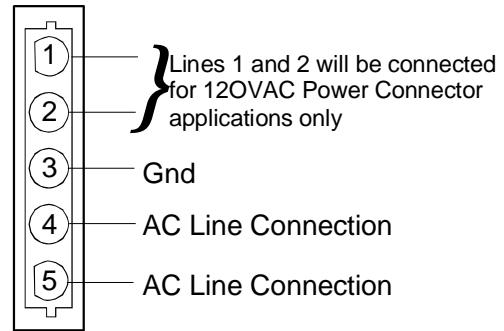

16-PIN ECM HARNESS CONNECTOR

If you do not read voltage and continuity as described, the problem is in the control or interface board, but not the motor. If you register voltage as described, the ECM power head is defective and must be replaced.



# SERVICING

Troubleshooting Chart for ECM Variable Speed Air Circulator Blower Motors				
Symptom	Fault Description(s)	Possible Causes	Corrective Action	Cautions and Notes
- Motor rocks slightly when starting.	- This is normal start-up for variable speed motor.	----	----	----
- Motor won't start.	- No movement.	<ul style="list-style-type: none"> <li>- Manual disconnect switch off or door switch open.</li> <li>- Blown fuse or circuit breaker.</li> <li>- 24 Vac wires miswired.</li> <li>- Unseated pins in wiring harness connectors.</li> <li>- Bad motor/control module.</li> <li>- Moisture present in motor or control module.</li> </ul>	<ul style="list-style-type: none"> <li>- Check 230 Vac power at motor.</li> <li>- Check low voltage (24 Vac R to C) at motor.</li> <li>- Check low voltage connections (G, Y, W, R, C) at motor.</li> <li>- Check for unseated pins in connectors on motor harness.</li> <li>- Test with a temporary jumper between R - G.</li> </ul>	<ul style="list-style-type: none"> <li>- Turn power OFF prior to repair. Wait 5 minutes after disconnecting power before opening motor.</li> <li>- Handle electronic motor/control with care.</li> </ul>
	- Motor rocks, but won't start.	<ul style="list-style-type: none"> <li>- Loose motor mount.</li> <li>- Blower wheel not tight on motor shaft.</li> <li>- Bad motor/control module.</li> </ul>	<ul style="list-style-type: none"> <li>- Check for loose motor mount.</li> <li>- Make sure blower wheel is tight on shaft.</li> <li>- Perform motor/control replacement check, ECM motors only.</li> </ul>	<ul style="list-style-type: none"> <li>- Turn power OFF prior to repair. Wait 5 minutes after disconnecting power before opening motor.</li> <li>- Handle electronic motor/control with care.</li> </ul>
- Motor oscillates up & down while being tested off of blower.	- It is normal for motor to oscillate with no load on shaft.	----	----	----
	- Varies up and down or intermittent.	<ul style="list-style-type: none"> <li>- Variation in 230 Vac to motor.</li> <li>- Unseated pins in wiring harness connectors.</li> <li>- Erratic CFM command from "BK" terminal.</li> <li>- Improper thermostat connection or setting.</li> <li>- Moisture present in motor/control module.</li> </ul>	<ul style="list-style-type: none"> <li>- Check line voltage for variation or "sag".</li> <li>- Check low voltage connections (G, Y, W, R, C) at motor, unseated pins in motor harness connectors.</li> <li>- Check-out system controls - Thermostat.</li> <li>- Perform Moisture Check.*</li> </ul>	<ul style="list-style-type: none"> <li>- Turn power OFF prior to repair.</li> </ul>
- Motor starts, but runs erratically.	- "Hunts" or "puffs" at high CFM (speed).	<ul style="list-style-type: none"> <li>- Incorrect or dirty filter(s).</li> <li>- Incorrect supply or return ductwork.</li> <li>- Incorrect blower speed setting.</li> </ul>	<ul style="list-style-type: none"> <li>- Does removing panel or filter reduce "puffing"?</li> <li>- Check/replace filter.</li> <li>- Check/correct duct restrictions.</li> <li>- Adjust to correct blower speed setting.</li> </ul>	<ul style="list-style-type: none"> <li>- Turn power OFF prior to repair.</li> </ul>

**\*Moisture Check**

- Connectors are oriented "down" (or as recommended by equipment manufacturer).
- Is condensate drain plugged?
- Check for undercharged conditior.

**Note:** You must use the correct replacement control/motor module since they are factory programmed for specific operating modes. Even though they look alike, different modules may have completely different functionality. The ECM variable speed motors are c

**Important Note:** Using the wrong motor/control module voids all product warranties and may produce unexpected results.

**CHART CONTINUED ON NEXT PAGE**

## Troubleshooting Chart for ECM Variable Speed Air Circulator Blower Motors

Symptom	Fault Description(s)	Possible Causes	Corrective Action	Cautions and Notes
- Motor starts, but runs erratically.	- Stays at low CFM despite system call for cool or heat CFM.	- 24 Vac wires miswired or loose. - "R" missing/not connected at motor. - Fan in delay mode.	- Check low voltage (Thermostat) wires and connections. - Verify fan is not in delay mode - wait until delay complete. - Perform motor/control replacement check, ECM motors only.	- Turn power OFF prior to repair. Wait 5 minutes after disconnecting power before opening motor. - Handle electronic motor/control with care.
	- Stays at high CFM.	- "R" missing/not connected at motor. - Fan in delay mode.	- Is fan in delay mode? - wait until delay time complete. - Perform motor/control replacement check, ECM motors only.	- Turn power OFF prior to repair. Wait 5 minutes after disconnecting power before opening motor. - Handle electronic motor/control with care.
	- Blower won't shut off.	- Current leakage from controls into G, Y, or W.	- Check for Triac switched t'stat or solid state relay.	- Turn power OFF prior to repair.
	- Air noise.	- High static creating high blower speed. - Incorrect supply or return ductwork. - Incorrect or dirty filter(s). - Incorrect blower speed setting.	- Check/replace filter. - Check/correct duct restrictions. - Adjust to correct blower speed setting.	- Turn power OFF prior to repair.
- Excessive noise.	- Noisy blower or cabinet.	- Loose blower housing, panels, etc. - High static creating high blower speed. - Air leaks in ductwork, cabinets, or panels.	- Check for loose blower housing, panels, etc. - Check for air whistling thru seams in ducts, cabinets or panels. - Check for cabinet/duct deformation.	- Turn power OFF prior to repair.
	- "Hunts" or "puffs" at high CFM (speed).	- High static creating high blower speed. - Incorrect or dirty filter(s). - Incorrect supply or return ductwork. - Incorrect blower speed setting.	- Does removing panel or filter reduce "puffing"? - Check/replace filter. - Check/correct duct restrictions. - Adjust to correct blower speed setting.	- Turn power OFF prior to repair.
- Evidence of Moisture.	- Motor failure or malfunction has occurred and moisture is present.	- Moisture in motor/control module.	- Replace motor and perform Moisture Check.*	- Turn power OFF prior to repair. Wait 5 minutes after disconnecting power before opening motor. - Handle electronic motor/control with care.

**\*Moisture Check**

- Connectors are oriented "down" (or as recommended by equipment manufacturer).
- Is condensate drain plugged?
- Check for unobstructed condensation.

**Note:** You must use the correct replacement control/motor module since they are factory programmed for specific operating modes. Even though they look alike, different modules may have completely different functionality. The ECM variable speed motors are c

**Important Note:** Using the wrong motor/control module voids all product warranties and may produce unexpected results.

- Arrange harnesses with "drip loop" under motor.
- Check for low airflow (too much latent capacity).
- Check and plug leaks in return ducts, cabinet.



# SERVICING

## S-16C CHECKING ECM MOTOR WINDINGS



**WARNING**

**HIGH VOLTAGE**  
 Disconnect ALL power before servicing or installing this unit. Multiple power sources may be present. Failure to do so may cause property damage, personal injury or death.



1. Disconnect the 5-pin and the 16-pin connectors from the ECM power head.
2. Remove the 2 screws securing the ECM power head and separate it from the motor.
3. Disconnect the 3-pin motor connector from the power head and lay it aside.
4. Using an ohmmeter, check the motor windings for continuity to ground (pins to motor shell). If the ohmmeter indicates continuity to ground, the motor is defective and must be replaced.
5. Using an ohmmeter, check the windings for continuity (pin to pin). If no continuity is indicated, the thermal limit (over load) device may be open. Allow motor to cool and retest.

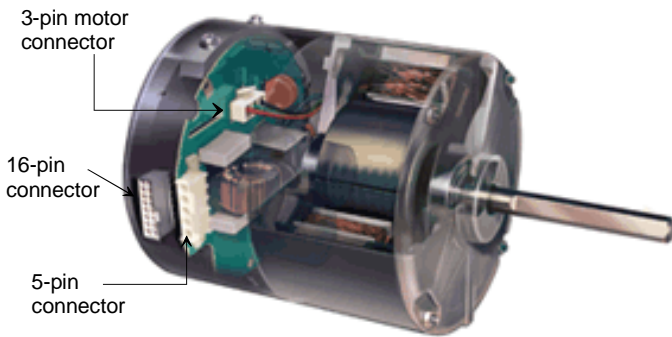

## S-16D ECM CFM ADJUSTMENTS

### MBE MOTOR

This section references the operation characteristics of the MBE model motor only. The ECM control board is factory set with the dipswitch #4 in the "ON" position and all other dipswitches are factory set in the "OFF" position. When MBE is used with 2-stage cooling units, dipswitch #4 should be in the "OFF" position.

***For most applications, the settings are to be changed according to the electric heat size and the outdoor unit selection.***

The MBE product uses a General Electric ECM™ motor. This motor provides many features not available on the traditional PSC motor. These features include:

- Improved Efficiency
- Constant CFM
- Soft Start and Stop
- Improved Humidity Control

## MOTOR SPEED ADJUSTMENT

Each ECM™ blower motor has been preprogrammed for operation at 4 distinct airflow levels when operating in Cooling/Heat Pump mode or Electric Heat mode. These 4 distinct levels may also be adjusted slightly lower or higher if desired. The adjustment between levels and the trim adjustments are made by changing the dipswitch(s) either to an "OFF" or "ON" position.

## DIPSWITCH FUNCTIONS

The MBE air handler motor has an electronic control that contains an eight (8) position dip switch. The function of these dipswitches are shown in **Table 1**.

Dipswitch Number	Function
1	Electric Heat
2	
3	N/A
4	Indoor Thermostat
5	Cooling & Heat Pump CFM
6	
7	CFM Trim Adjust
8	

Table 1

## CFM DELIVERY

**Tables 2 and 3** show the CFM output for dipswitch combinations 1-2, and 5-6.

### Electric Heat Operation

Model	Switch 1	Switch 2	CFM
MBE1200	OFF	OFF	1,200
	ON	OFF	1,000
	OFF	ON	800
	ON	ON	600
MBE1600	OFF	OFF	1,600
	ON	OFF	1,400
	OFF	ON	1,200
	ON	ON	1,000
MBE2000	OFF	OFF	2,000
	ON	OFF	1,800
	OFF	ON	1,600
	ON	ON	1,200
AEPT30	OFF	OFF	1,100
	ON	OFF	850
	OFF	ON	700
AEPT36/60	OFF	OFF	2,050
	ON	OFF	1,750
	OFF	ON	1,600
	OFF	ON	1,200

Table 2

# SERVICING

## Cooling/Heat Pump Operation

Model	Switch 5	Switch 6	CFM
MBE1200	OFF	OFF	1,200
	ON	OFF	1,000
	OFF	ON	800
	ON	ON	600
MBE1600	OFF	OFF	1,600
	ON	OFF	1,400
	OFF	ON	1,200
	ON	ON	1,000
MBE2000	OFF	OFF	1,600
	ON	OFF	1,400
	OFF	ON	1,200
	ON	ON	1,000
AEPT30	OFF	OFF	1,100
	ON	OFF	800
	OFF	ON	600
AEPT36/60	OFF	OFF	1,800
	ON	OFF	1,580
	OFF	ON	1,480
	ON	ON	1,200

Table 3

### THERMOSTAT "FAN ONLY" MODE

During Fan Only Operations, the CFM output is 30% of the cooling setting.

### CFM TRIM ADJUST

Minor adjustments can be made through the dip switch combination of 7-8. **Table 4** shows the switch position for this feature.

**NOTE:** The airflow will not make the decreasing adjustment in Electric Heat mode.

CFM	Switch 7	Switch 8
+10%	ON	OFF
-15%	OFF	ON

Table 4

### HUMIDITY CONTROL

When using a Humidstat (normally closed), cut jumper PJ6 on the control board. The Humidstat will only affect cooling airflow by adjusting the Airflow to 85%.

### TWO STAGE HEATING

When using staged electric heat, cut jumper PJ4 on the control board.

## S-17 CHECKING COMPRESSOR



### WARNING

Hermetic compressor electrical terminal venting can be dangerous. When insulating material which supports a hermetic compressor or electrical terminal suddenly disintegrates due to physical abuse or as a result of an electrical short between the terminal and the compressor housing, the terminal may be expelled, venting the vapor and liquid contents of the compressor housing and system.

If the compressor terminal PROTECTIVE COVER and gasket (if required) are not properly in place and secured, there is a remote possibility if a terminal vents, that the vaporous and liquid discharge can be ignited, spouting flames several feet, causing potentially severe or fatal injury to anyone in its path.

This discharge can be ignited external to the compressor if the terminal cover is not properly in place and if the discharge impinges on a sufficient heat source.

Ignition of the discharge can also occur at the venting terminal or inside the compressor, if there is sufficient contaminant air present in the system and an electrical arc occurs as the terminal vents.

Ignition cannot occur at the venting terminal without the presence of contaminant air, and cannot occur externally from the venting terminal without the presence of an external ignition source.

Therefore, proper evacuation of a hermetic system is essential at the time of manufacture and during servicing.

To reduce the possibility of external ignition, all open flame, electrical power, and other heat sources should be extinguished or turned off prior to servicing a system.

If the following test indicates shorted, grounded or open windings, see procedures S-19 for the next steps to be taken.

### S-17A RESISTANCE TEST

Each compressor is equipped with an internal overload.

The line break internal overload senses both motor amperage and winding temperature. High motor temperature or amperage heats the disc causing it to open, breaking the common circuit within the compressor on single phase units.

Heat generated within the compressor shell, usually due to recycling of the motor, high amperage or insufficient gas to cool the motor, is slow to dissipate. Allow at least three to four hours for it to cool and reset, then retest.

Fuse, circuit breaker, ground fault protective device, etc. has not tripped -

# SERVICING

**WARNING**  
**HIGH VOLTAGE**  
 Disconnect ALL power before servicing or installing this unit. Multiple power sources may be present. Failure to do so may cause property damage, personal injury or death.



1. Remove the leads from the compressor terminals.

**WARNING**  
 See warnings S-17 page 28 before removing compressor terminal cover.

2. Using an ohmmeter, test continuity between terminals S-R, C-R, and C-S, on single phase units or terminals T2, T2 and T3, on 3 phase units.

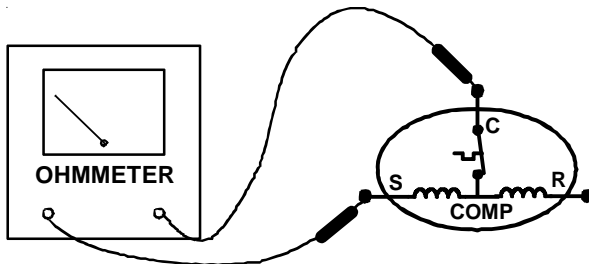

### TESTING COMPRESSOR WINDINGS

If either winding does not test continuous, replace the compressor.

**NOTE:** If an open compressor is indicated, allow ample time for the internal overload to reset before replacing compressor.

### S-17B GROUND TEST

If fuse, circuit breaker, ground fault protective device, etc., has tripped, this is a strong indication that an electrical problem exists and must be found and corrected. The circuit protective device rating must be checked, and its maximum rating should coincide with that marked on the equipment nameplate.

With the terminal protective cover in place, it is acceptable to replace the fuse or reset the circuit breaker ONE TIME ONLY to see if it was just a nuisance opening. If it opens again, DO NOT continue to reset.

**Disconnect all power to unit**, making sure that **all** power legs are open.

1. DO NOT remove protective terminal cover. Disconnect the three leads going to the compressor terminals at the nearest point to the compressor.
2. Identify the leads and using a Megger, Hi-Potential Ground Tester, or other suitable instrument which puts out a voltage between 300 and 1500 volts, check for a ground separately between each of the three leads and ground (such as an unpainted tube on the compressor). Do not use a low voltage output instrument such as a volt-ohmmeter.

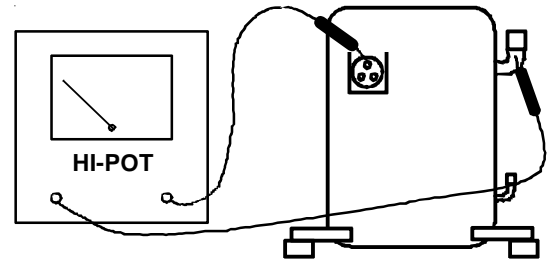

### COMPRESSOR GROUND TEST

3. If a ground is indicated, then carefully remove the compressor terminal protective cover and inspect for loose leads or insulation breaks in the lead wires.
4. If no visual problems indicated, carefully remove the leads at the compressor terminals.

**WARNING**  
 Damage can occur to the glass embedded terminals if the leads are not properly removed. This can result in terminal and hot oil discharging.

Carefully retest for ground, directly between compressor terminals and ground.

5. If ground is indicated, replace the compressor.

### S-17D OPERATION TEST

If the voltage, capacitor, overload and motor winding test fail to show the cause for failure:

**WARNING**  
**HIGH VOLTAGE**  
 Disconnect ALL power before servicing or installing this unit. Multiple power sources may be present. Failure to do so may cause property damage, personal injury or death.



1. Remove unit wiring from disconnect switch and wire a test cord to the disconnect switch.

**NOTE:** The wire size of the test cord must equal the line wire size and the fuse must be of the proper size and type.

2. With the protective terminal cover in place, use the three leads to the compressor terminals that were disconnected at the nearest point to the compressor and connect the common, start and run clips to the respective leads.
3. Connect good capacitors of the right MFD and voltage rating into the circuit as shown.
4. With power ON, close the switch.

**WARNING**  
 Line Voltage now present.

## SERVICING

- A. If the compressor starts and continues to run, the cause for failure is somewhere else in the system.
- B. If the compressor fails to start - replace.

### COPELAND COMPRESSOR

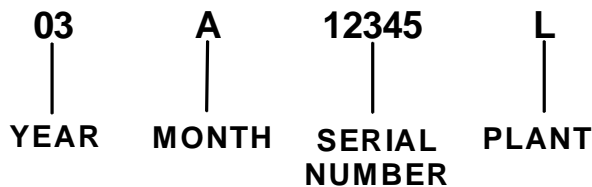

### S-18 TESTING CRANKCASE HEATER (OPTIONAL ITEM)

*The crankcase heater must be energized a minimum of four (4) hours before the condensing unit is operated.*

Crankcase heaters are used to prevent migration or accumulation of refrigerant in the compressor crankcase during the off cycles and prevents liquid slugging or oil pumping on start up.

*A crankcase heater will not prevent compressor damage due to a floodback or over charge condition.*



#### WARNING

**Disconnect ALL power before servicing.**

1. Disconnect the heater lead in wires.
2. Using an ohmmeter, check heater continuity - should test continuous. If not, replace.

**NOTE:** The positive temperature coefficient crankcase heater is a 40 watt 265 voltage heater. The cool resistance of the heater will be approximately 1800 ohms. The resistance will become greater as the temperature of the compressor shell increases.

### S-21 CHECKING REVERSING VALVE AND SOLENOID

Occasionally the reversing valve may stick in the heating or cooling position or in the mid-position.

When stuck in the mid-position, part of the discharge gas from the compressor is directed back to the suction side, resulting in excessively high suction pressure. An increase in the suction line temperature through the reversing valve can also be measured. Check operation of the valve by starting the system and switching the operation from COOLING to HEATING cycle.

If the valve fails to change its position, test the voltage (24V) at the valve coil terminals, while the system is on the COOLING cycle.

If no voltage is registered at the coil terminals, check the operation of the thermostat and the continuity of the connecting wiring from the "O" terminal of the thermostat to the unit.

If voltage is registered at the coil, tap the valve body lightly while switching the system from HEATING to COOLING, etc. If this fails to cause the valve to switch positions, remove the coil connector cap and test the continuity of the reversing valve solenoid coil. If the coil does not test continuous - replace it.

If the coil test continuous and 24 volts is present at the coil terminals, the valve is inoperative - replace.

### S-40 AR\*F & MBR ELECTRONIC BLOWERS TIME DELAY RELAY

The MBR contains an Electronic Blower Time Delay Relay board, B1370735. This board provides on/off time delays for the blower motor in cooling and heat pump heating demands when "G" is energized.

During a cooling or heat pump heating demand, 24Vac is supplied to terminal "G" of the EBTDR to turn on the blower motor. The EBTDR initiates a 7 second delay on and then energizes it's onboard relay. The relay on the EBTDR board closes it's normally open contacts and supplies power to the blower motor. When the "G" input is removed, the EBTDR initiates a 65 second delay off. When the 65 seconds delay expires the onboard relay is de-energized and it's contacts open and remove power from the blower motor.

During an electric heat only demand, "W1" is energized but "G" is not. The blower motor is connected to the normally closed contacts of the relay on the EBTDR board. The other side of this set of contacts is connected to the heat sequencer on the heater assembly that provides power to the first heater element. When "W1" is energized, the sequencer will close it's contacts within 10 to 20 seconds to supply power to the first heater element and to the blower motor through the normally closed contacts on the relay on the EBTDR. When the "W1" demand is removed, the sequencer opens it contacts within 30 to 70 seconds and removes power from the heater element and the blower motor.

The EBTDR also contains a speedup terminal to reduce the delays during troubleshooting of the unit. When this terminal is shorted to the common terminal, "C", on the EBTDR board, the delay ON time is reduced to 3 seconds and the delay OFF time is reduced to 5 second.

Two additional terminals, M1 and M2, are on the EBTDR board. These terminals are used to connect the unused leads from the blower motor and have no affect on the board's operation.



# SERVICING

## SEQUENCE OF OPERATION

This document covers the basic sequence of operation for a typical application with a mercury bulb thermostat. When a digital/electronic thermostat is used, the on/off staging of the auxiliary heat will vary. **Refer to the installation instructions and wiring diagrams provided with the MBR and AR\*F for specific wiring connections and system configuration.**

### AR\*F & MBR

#### WITH SINGLE STAGE CONDENSERS

##### 1.0 Cooling Operation

- 1.1 On a demand for cooling, the room thermostat energizes “G” and “Y” and 24Vac is supplied to “Y” at the condensing unit and the “G” terminal on the EBTDR board.
- 1.2 The compressor and condenser fan are turned on and after a 7 second on delay, the relay on the EBTDR board is energized and the blower motor starts.
- 1.3 When the cooling demand “Y” is satisfied, the room thermostat removes the 24Vac from “G” and “Y”.
- 1.4 The compressor and condenser fan are turned off and after a 65 second delay off, the relay on the EBTDR board is de-energized and the blower is turned off.

##### 2.0 Heating Operation

- 2.1 On a demand for heat, the room thermostat energizes “W1” and 24Vac is supplied to heat sequencer, HR1, on the heater assembly.
- 2.2 The contacts M1 and M2 will close within 10 to 20 seconds and turn on heater element #1. The normally closed contacts on the EBTDR are also connected to terminal M1. When M1 and M2 close, the blower motor will be energized thru the normally closed contacts on the EBTDR board. At the same time, if the heater assembly contains a second heater element, HR1 will contain a second set of contacts, M3 and M4, which will close to turn on heater element #2.

**Note:** If more than two heater elements are on the heater assembly, it will contain a second heat sequencer, HR2, which will control the 3<sup>rd</sup> and 4<sup>th</sup> heater elements if available. If the first stage heat demand, “W1” cannot be satisfied by the heat pump, the temperature indoors will continue to drop. The room thermostat will then energize “W2” and 24Vac will be supplied to HR2 on the heater assembly. When the “W2” demand is satisfied, the room thermostat will remove the 24Vac from HR2. The contacts on HR2 will open between 30 to 70 seconds and heater elements #3 and #4 will be turned off. **On most digital/electronic thermostats, “W2” will remain energized until the first stage demand “W1” is satisfied and then the “W1” and “W2” demands will be removed.**

- 2.3 When the “W1” heat demand is satisfied, the room thermostat will remove the 24Vac from HR1. Both set of contacts on the relay opens within 30 to 70 seconds and turn off the heater element(s) and the blower motor.

### AR\*F & MBR

#### WITH SINGLE STAGE HEAT PUMPS

##### 3.0 Cooling Operation

On heat pump units, when the room thermostat set to the cooling mode, 24Vac is supplied to “O” which energizes the reversing valve. As long as the thermostat is set for cooling, the reversing valve will be in the energized position for cooling.

- 3.1 On a demand for cooling, the room thermostat energizes “G” and “Y” and 24Vac is supplied to “Y” at the heat pump and the “G” terminal on the EBTDR board.
- 3.2 The heat pump turned on in the cooling mode and after a 7 second on delay, the relay on the EBTDR board is energized and the blower motor starts.
- 3.3 When the cooling demand is satisfied, the room thermostat removes the 24Vac from “G” and “Y”.
- 3.4 The heat pump is turned off and after a 65 second delay off, the relay on the EBTDR board is de-energized and the blower motor is turned off.

##### 4.0 Heating Operation

On heat pump units, when the room thermostat set to the heating mode, the reversing valve is not energized. As long as the thermostat is set for heating, the reversing valve will be in the de-energized position for heating except during a defrost cycle. Some installations may use one or more outdoor thermostats to restrict the amount of electric heat that is available above a preset ambient temperature. Use of optional controls such as these can change the operation of the electric heaters during the heating mode. This sequence of operation does not cover those applications.

- 4.1 On a demand for first stage heat with heat pump units, the room thermostat energizes “G” and “Y” and 24Vac is supplied to “Y” at the heat pump unit and the “G” terminal on the EBTDR board. The heat pump is turned on in the heating mode and the blower motor starts after a 7 second on delay.
- 4.2 If the first stage heat demand cannot be satisfied by the heat pump, the temperature indoors will continue to drop. The room thermostat will then energize terminal “W2” for second stage heat and 24Vac will be supplied to heat sequencer HR1 on the heater assembly.
- 4.3 HR1 contacts M1 and M2 will close will close within 10 to 20 seconds and turn on heater element #1. At the same time, if the heater assembly contains a second heater element, HR1 will contain a second set of contacts, M3 and M4, which will close and turn on heater element #2. The blower motor is already on as a result of terminal “G” on the EBTDR board being energized for the first stage heat demand.

# SERVICING

**Note:** If more than two heater elements are on the heater assembly, it will contain a second heat sequencer, HR2, which will control the 3<sup>rd</sup> and 4<sup>th</sup> heater elements if available. If the second stage heat demand, “W2” cannot be satisfied by the heat pump, the temperature indoors will continue to drop. The room thermostat will then energize “W3” and 24Vac will be supplied to HR2 on the heater assembly. When the “W3” demand is satisfied, the room thermostat will remove the 24Vac from HR2. The contacts on HR2 will open between 30 to 70 seconds and heater elements #3 and #4 will be turned off. **On most digital/electronic thermostats, “W3” will remain energized until the first stage heat demand “Y” is satisfied and then the “G”, “Y”, “W2” and “W3” demands will be removed.**

4.4 As the temperature indoors increase, it will reach a point where the second stage heat demand, “W2”, is satisfied. When this happens, the room thermostat will remove the 24Vac from the coil of HR1. The contacts on HR1 will open between 30 to 70 seconds and turn off both heater element(s). The heat pump remains on along with the blower motor because the “Y” demand for first stage heat will still be present.

4.5 When the first stage heat demand “Y” is satisfied, the room thermostat will remove the 24Vac from “G” and “Y”. The heat pump is turned off and the blower motor turns off after a 65 second off delay.

## 5.0 Defrost Operation

On heat pump units, when the room thermostat is set to the heating mode, the reversing valve is not energized. As long as the thermostat is set for heating, the reversing valve will be in the de-energized position for heating except during a defrost cycle.

5.1 The heat pump will be on and operating in the heating mode as described the Heating Operation in section 4.

5.2 The defrost control in the heat pump unit checks to see if a defrost is needed every 30, 60 or 90 minutes of heat pump operation depending on the selectable setting by monitoring the state of the defrost thermostat attached to the outdoor coil.

5.3 If the temperature of the outdoor coil is low enough to cause the defrost thermostat to be closed when the defrost board checks it, the board will initiate a defrost cycle.

5.4 When a defrost cycle is initiated, the contacts of the HVDR relay on the defrost board open and turns off the outdoor fan. The contacts of the LVDR relay on the defrost board closes and supplies 24Vac to “O” and “W2”. The reversing valve is energized and the contacts on HR1 close and turns on the electric heater(s). The unit will continue to run in this mode until the defrost cycle is completed.

5.5 When the temperature of the outdoor coil rises high enough to causes the defrost thermostat to open, the defrost cycle will be terminated. If at the end of the programmed 10 minute override time the defrost thermostat is still closed, the defrost board will automatically terminate the defrost cycle.

5.6 When the defrost cycle is terminated, the contacts of the HVDR relay will close to start the outdoor fan and the contacts of the LVDR relay will open and turn off the reversing valve and electric heater(s). The unit will now be back in a normal heating mode with a heat pump demand for heating as described in the Heating Operation in section 4.

## **S-41 AEP\* & MBE WITH SINGLE STATE CONDENSERS**

### **AEP\* & MBE ELECTRONIC BLOWER TIME DELAY RELAY**

#### SEQUENCE OF OPERATION

This document covers the basic sequence of operation for a typical application with a mercury bulb thermostat. When a digital/electronic thermostat is used, the on/off staging of the auxiliary heat will vary. Refer to the installation instructions and wiring diagrams provided with the MBE for specific wiring connections, dip switch settings and system configuration.

### **AEP\* & MBE WITH SINGLE STAGE CONDENSERS**

When used with a single stage condenser, dip switch #4 must be set to the on position on the VSTB inside the MBE. The “Y” output from the indoor thermostat must be connected to the yellow wire labeled “Y/Y2” inside the wire bundle marked “Thermostat” and the yellow wire labeled “Y/Y2” inside the wire bundle marked “Outdoor Unit” must be connected to “Y” at the condenser. The orange jumper wire from terminal “Y1” to terminal “O” on the VSTB inside the MBE must remain connected.

#### 1.0 Cooling Operation

1.1 On a demand for cooling, the room thermostat energizes “G” and “Y” and 24Vac is supplied to “G” and “Y/Y2” of the MBE unit. The VSTB inside the MBE will turn on the blower motor and the motor will ramp up to the speed programmed in the motor based on the settings for dip switch 5 and 6. The VSTB will supply 24Vac to “Y” at the condenser and the compressor and condenser are turned on.

1.2 When the cooling demand is satisfied, the room thermostat removes the 24Vac from “G” and “Y”. The MBE and AEP\* remove the 24Vac from “Y” at the condenser and the compressor and condenser fan are turned off. The blower motor will ramp down to a complete stop based on the time and rate programmed in the motor.

# SERVICING

## 2.0 Heating Operation

**2.1** On a demand for heat, the room thermostat energizes “W1” and 24Vac is supplied to terminal “E/W1” of the VSTB inside the MBE and AEP\* units. The VSTB will turn on the blower motor and the motor will ramp up to the speed programmed in the motor based on the settings for dip switch 1 and 2. The VSTB will supply 24Vac to heat sequencer HR1 on the electric heater assembly.

**2.2** HR1 contacts M1 and M2 will close within 10 to 20 seconds and turn on heater element #1. At the same time, if the heater assembly contains a second heater element, HR1 will contain a second set of contacts, M3 and M4, which will close and turn on heater element #2.

**Note:** If more than two heater elements are on the heater assembly, it will contain a second heat sequencer, HR2, which will control the 3<sup>rd</sup> and 4<sup>th</sup> heater elements if available. **For the 3<sup>rd</sup> and 4<sup>th</sup> heater elements to operate on a second stage heat demand, the PJ4 jumper on the VSTB inside the MBE and AEP\* must be cut.** With the PJ4 jumper cut, the VSTB will run the blower motor on low speed on a “W1” only demand. If the first stage heat demand, “W1” cannot be satisfied by the heat pump, the temperature indoors will continue to drop. The room thermostat will then energize “W2” and 24Vac will be supplied to HR2 on the heater assembly and the blower motor will change to high speed. When the “W2” demand is satisfied, the room thermostat will remove the 24Vac from “W2” and the VSTB will remove the 24Vac from HR2. The contacts on HR2 will open between 30 to 70 seconds and heater elements #3 and #4 will be turned off and the blower motor will change to low speed. **On most digital/electronic thermostats, “W2” will remain energized until the first stage demand “W1” is satisfied and then the “W1” and “W2” demands will be removed.**

**2.3** When the “W1” heat demand is satisfied, the room thermostat will remove the 24Vac from “E/W1” and the VSTB removes the 24Vac from HR1. The contacts on HR1 will open between 30 to 70 seconds and turn off the heater element(s) and the blower motor ramps down to a complete stop.

### **AEP\* & MBE WITH SINGLE STAGE HEAT PUMPS**

When used with a single stage heat pump, dip switch #4 must be set to the ON position on the VSTB inside the MBE. The “Y” output from the indoor thermostat must be connected to the yellow wire labeled “Y/Y2” inside the wire bundle marked “Thermostat” and the yellow wire labeled “Y/Y2” inside the wire bundle marked “Outdoor Unit” must be connected to “Y” at the heat pump. **The orange jumper wire from terminal “Y1” to terminal “O” on the VSTB inside the MBE must be removed.**

## 3.0 Cooling Operation

On heat pump units, when the room thermostat is set to the cooling mode, 24Vac is supplied to terminal “O” of the VSTB inside the MBE unit. The VSTB will supply 24Vac to “O” at the heat pump to energize the reversing valve. As long as the thermostat is set for cooling, the reversing valve will be in the energized position for cooling.

**3.1** On a demand for cooling, the room thermostat energizes “G” and “Y” and 24Vac is supplied to terminals “G” and “Y/Y2” of the MBE unit. The VSTB will turn on the blower motor and the motor will ramp up to the speed programmed in the motor based on the settings of dip switch 5 and 6. The VSTB will supply 24Vac to “Y” at the heat pump.

**3.2** The heat pump is turned on in the cooling mode.

**3.3** When the cooling demand is satisfied, the room thermostat removes the 24Vac from “G” and “Y/Y2” of the MBE and the VSTB removes the 24Vac from “Y” at the heat pump. The heat pump is turned off and the blower motor will ramp down to a complete stop based on the time and rate programmed in the motor.

## 4.0 Heating Operation

On heat pump units, when the room thermostat is set to the heating mode, the reversing valve is not energized. As long as the thermostat is set for heating, the reversing valve will be in the de-energized position for heating except during a defrost cycle. Some installations may use one or more outdoor thermostats to restrict the amount of electric heat that is available above a preset ambient temperature. Use of optional controls such as these can change the operation of the electric heaters during the heating mode. This sequence of operation does not cover those applications.

**4.1** On a demand for first stage heat with heat pump units, the room thermostat energizes “Y” and “G” and 24Vac is supplied to “G” and “Y/Y2” of the MBE. The VSTB will turn on the blower motor and the motor will ramp up to the speed programmed in the motor based on the settings of dip switch 1 and 2. The VSTB will supply 24Vac to “Y” at the heat pump and the heat pump is turned on in the heating mode.

**4.2** If the first stage heat demand cannot be satisfied by the heat pump, the temperature indoors will continue to drop. The room thermostat will then energize terminal “W2” for second stage heat and 24Vac will be supplied to “E/W1” of the MBE. The VSTB will supply 24Vac to heat sequencer, HR1, on the electric heater assembly.

**4.3** HR1 contacts M1 and M2 will close within 10 to 20 seconds and turn on heater element #1. At the same time, if the heater assembly contains a second heater element, HR1 will contain a second set of contacts, M3 and M4, which will close to turn on heater element #2.



# SERVICING

**Note:** If more than two heater elements are on the heater assembly, it will contain a second heat sequencer, HR2, which will control the 3<sup>rd</sup> and 4<sup>th</sup> heater elements if available.

**For the 3<sup>rd</sup> and 4<sup>th</sup> heater elements to operate on a third stage heat demand, the PJ4 jumper on the VSTB inside the MBE and AEP\* must be cut.** If the second stage heat demand, “W2”, cannot be satisfied by the heat pump, the temperature indoors will continue to drop. The room thermostat will then energize “W3” and 24Vac will be supplied to “W/W2” of the MBE. The VSTB will supply 24Vac to HR2 on the electric heater assembly. When the “W3” demand is satisfied, the room thermostat will remove the 24Vac from “W/W2” of the MBE and AEP\*. The contacts on HR2 will open between 30 to 70 seconds and heater elements #3 and #4 will be turned off. **On most digital/electronic thermostats, “W3” will remain energized until the first stage demand “Y” is satisfied and then the “G”, “Y”, “W2” and “W3” demands will be removed.**

**4.4** As the temperature indoors increase, it will reach a point where the second stage heat demand, “W2”, is satisfied. When this happens, the room thermostat will remove the 24Vac from “E/W1” of the MBE. The contacts on HR1 will open between 30 to 70 seconds and turn off both heater element(s). The heat pump remains on along with the blower motor because the “Y” demand for first stage heat will still be present.

**4.5** When the first stage heat demand “Y” is satisfied, the room thermostat will remove the 24Vac from “G” and “Y/Y2” of the MBE and AEP\*. The VSTB removes the 24Vac from “Y” at the heat pump and the heat pump is turned off. The blower motor will ramp down to a complete stop based on the time and rate programmed in the motor control.

## 5.0 Defrost Operation

On heat pump units, when the room thermostat is set to the heating mode, the reversing valve is not energized. As long as the thermostat is set for heating, the reversing valve will be in the de-energized position for heating except during a defrost cycle.

**5.1** The heat pump will be on and operating in the heating mode as described the Heating Operation in section 4.

**5.2** The defrost control in the heat pump unit checks to see if a defrost is needed every 30, 60 or 90 minutes of heat pump operation depending on the selectable setting by monitoring the state of the defrost thermostat attached to the outdoor coil.

**5.3** If the temperature of the outdoor coil is low enough to cause the defrost thermostat to be closed when the defrost board checks it, the board will initiate a defrost cycle.

**5.4** When a defrost cycle is initiated, the contacts of the HVDR relay on the defrost board open and turns off the outdoor fan. The contacts of the LVDR relay on the defrost board closes and supplies 24Vac to “O” and “W2”. The reversing valve is energized and the contacts on HR1 close and turns on the electric heater(s). The unit will continue to run in this mode until the defrost cycle is completed.

**5.5** When the temperature of the outdoor coil rises high enough to causes the defrost thermostat to open, the defrost cycle will be terminated. If at the end of the programmed 10 minute override time the defrost thermostat is still closed, the defrost board will automatically terminate the defrost cycle.

**5.6** When the defrost cycle is terminated, the contacts of the HVDR relay on the defrost board will close to start the outdoor fan and the contacts of the LVDR relay will open and turn off the reversing valve and electric heater(s). The unit will now be back in a normal heating mode with a heat pump demand for heating as described in the Heating Operation in section 4.

## S-60 ELECTRIC HEATER (OPTIONAL ITEM)

Optional electric heaters may be added, in the quantities shown in the specifications section, to provide electric resistance heating. Under no condition shall more heaters than the quantity shown be installed.

The low voltage circuit in the air handler is factory wired and terminates at the location provided for the electric heater(s). A minimum of field wiring is required to complete the installation.

Other components such as a Heating/Cooling Thermostat and Outdoor Thermostats are available to complete the installation.

The system CFM can be determined by measuring the static pressure external to the unit. The installation manual supplied with the blower coil, or the blower performance table in the service manual, shows the CFM for the static measured.

Alternately, the system CFM can be determined by operating the electric heaters and indoor blower WITHOUT having the compressor in operation. Measure the temperature rise as close to the blower inlet and outlet as possible.

If other than a 240V power supply is used, refer to the **BTUH CAPACITY CORRECTION FACTOR** chart below.

BTUH CAPACITY CORRECTION FACTOR				
SUPPLY VOLTAGE	250	230	220	208
MULTIPLICATION FACTOR	1.08	.92	.84	.75



# SERVICING

**EXAMPLE:** Five (5) heaters provide 24.0 KW at the rated 240V. Our actual measured voltage is 220V, and our measured temperature rise is 42°F. Find the actual CFM:

**Answer:** 24.0KW, 42°F Rise, 240 V = 1800 CFM from the **TEMPERATURE RISE CHART**, Table 5.

Heating output at 220 V = 24.0KW x 3.413 x .84 = 68.8 MBH.

Actual CFM = 1800 x .84 Corr. Factor = 1400 CFM.

**NOTE:** The temperature rise table is for sea level installations. The temperature rise at a particular KW and CFM will be greater at high altitudes, while the external static pressure at a particular CFM will be less.

TEMPERATURE RISE (F°) @ 240V							
CFM	4.8 KW	7.2 KW	9.6 KW	14.4 KW	19.2 KW	24.0 KW	28.8 KW
600	25	38	51	-	-	-	-
700	22	33	43	-	-	-	-
800	19	29	38	57	-	-	-
900	17	26	34	51	-	-	-
1000	15	23	30	46	-	-	-
1100	14	21	27	41	55	-	-
1200	13	19	25	38	50	-	-
1300	12	18	23	35	46	-	-
1400	11	16	22	32	43	54	65
1500	10	15	20	30	40	50	60
1600	9	14	19	28	38	47	57
1700	9	14	18	27	36	44	53
1800	8	13	17	25	34	42	50
1900	8	12	16	24	32	40	48
2000	8	12	15	23	30	38	45
2100	7	11	14	22	29	36	43
2200	7	11	14	21	27	34	41
2300	7	10	13	20	26	33	39

Table 5

ELECTRIC HEATER CAPACITY BTUH								
HTR KW	3.0 KW	4.7 KW	6.0 KW	7.0 KW	9.5 KW	14.2 KW	19.5 KW	21.0 KW
BTUH	10200	16200	20400	23800	32400	48600	66500	71600

Table 6

## FORMULAS:

Heating Output = KW x 3413 x Corr. Factor

Actual CFM = CFM (from table) x Corr. Factor

BTUH = KW x 3413

BTUH = CFM x 1.08 x Temperature Rise (T)

CFM =  $\frac{KW \times 3413}{1.08 \times T}$

T =  $\frac{BTUH}{CFM \times 1.08}$

## S-61A CHECKING HEATER LIMIT CONTROL(S)

Each individual heater element is protected with a limit control device connected in series with each element to prevent overheating of components in case of low airflow. This limit control will open its circuit at approximately 150°F.



### WARNING

**HIGH VOLTAGE**  
Disconnect ALL power before servicing or installing this unit. Multiple power sources may be present. Failure to do so may cause property damage, personal injury or death.



1. Remove the wiring from the control terminals.
2. Using an ohmmeter, test for continuity across the normally closed contacts. No reading indicates the control is open - replace if necessary.

IF FOUND OPEN - REPLACE - DO NOT WIRE AROUND.

## S-61B CHECKING HEATER FUSE LINK (OPTIONAL ELECTRIC HEATERS)

Each individual heater element is protected with a one time fuse link which is connected in series with the element. The fuse link will open at approximately 333°.



### WARNING

**Disconnect ALL power before servicing.**

1. Remove heater element assembly so as to expose fuse link.
2. Using an ohmmeter, test across the fuse link for continuity - no reading indicates the link is open. Replace as necessary.

**NOTE:** The link is designed to open at approximately 333°F. DO NOT WIRE AROUND - determine reason for failure.

# SERVICING

## S-62 CHECKING HEATER ELEMENTS



### WARNING

Disconnect ALL power before servicing.

1. Disassemble and remove the heating element.
2. Visually inspect the heater assembly for any breaks in the wire or broken insulators.
3. Using an ohmmeter, test the element for continuity - no reading indicates the element is open. Replace as necessary.

## S-100 REFRIGERATION REPAIR PRACTICE



### DANGER

Always remove the refrigerant charge in a proper manner before applying heat to the system.

When repairing the refrigeration system:



### WARNING

Disconnect ALL power before servicing.

1. Never open a system that is under vacuum. Air and moisture will be drawn in.
2. Plug or cap all openings.
3. Remove all burrs and clean the brazing surfaces of the tubing with sand cloth or paper. Brazing materials do not flow well on oxidized or oily surfaces.
4. Clean the inside of all new tubing to remove oils and pipe chips.
5. When brazing, sweep the tubing with dry nitrogen to prevent the formation of oxides on the inside surfaces.
6. Complete any repair by replacing the liquid line drier in the system, evacuate and charge.

### BRAZING MATERIALS

**Copper to Copper Joints** - Sil-Fos used without flux (alloy of 15% silver, 80% copper, and 5% phosphorous). Recommended heat 1400°F.

**Copper to Steel Joints** - Silver Solder used without a flux (alloy of 30% silver, 38% copper, 32% zinc). Recommended heat - 1200°F.

## S-101 LEAK TESTING (NITROGEN OR NITROGEN-TRACED)



### WARNING

To avoid the risk of fire or explosion, never use oxygen, high pressure air or flammable gases for leak testing of a refrigeration system.



### WARNING

To avoid possible explosion, the line from the nitrogen cylinder must include a pressure regulator and a pressure relief valve. The pressure relief valve must be set to open at no more than 150 psig.

Pressure test the system using dry nitrogen and soapy water to locate leaks. If you wish to use a leak detector, charge the system to 10 psi using the appropriate refrigerant then use nitrogen to finish charging the system to working pressure, then apply the detector to suspect areas. If leaks are found, repair them. After repair, repeat the pressure test. If no leaks exist, proceed to system evacuation.

## S-102 EVACUATION



### WARNING

**REFRIGERANT UNDER PRESSURE!**  
Failure to follow proper procedures may cause property damage, personal injury or death.

This is the most important part of the entire service procedure. The life and efficiency of the equipment is dependent upon the thoroughness exercised by the serviceman when evacuating air (non-condensables) and moisture from the system.

Air in a system causes high condensing temperature and pressure, resulting in increased power input and reduced performance.

Moisture chemically reacts with the refrigerant oil to form corrosive acids. These acids attack motor windings and parts, causing breakdown.

The equipment required to thoroughly evacuate the system is a high vacuum pump, capable of producing a vacuum equivalent to 25 microns absolute and a thermocouple vacuum gauge to give a true reading of the vacuum in the system

**NOTE:** Never use the system compressor as a vacuum pump or run when under a high vacuum. Motor damage could occur.



### WARNING

Do not front seat the service valve(s) with the compressor open, with the suction line of the compressor closed or severely restricted.

1. Connect the vacuum pump, vacuum tight manifold set with high vacuum hoses, thermocouple vacuum gauge and charging cylinder as shown.

# SERVICING

2. Start the vacuum pump and open the shut off valve to the high vacuum gauge manifold only. After the compound gauge (low side) has dropped to approximately 29 inches of vacuum, open the valve to the vacuum thermocouple gauge. See that the vacuum pump will blank-off to a maximum of 25 microns. A high vacuum pump can only produce a good vacuum if its oil is non-contaminated.

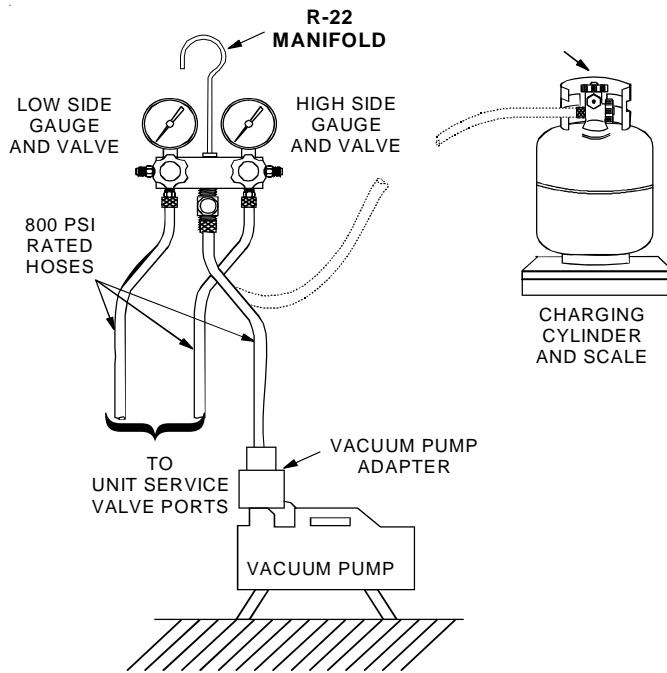

## EVACUATION

3. If the vacuum pump is working properly, close the valve to the vacuum thermocouple gauge and open the high and low side valves to the high vacuum manifold set. With the valve on the charging cylinder closed, open the manifold valve to the cylinder.
4. Evacuate the system to at least 29 inches gauge before opening valve to thermocouple vacuum gauge.
5. Continue to evacuate to a maximum of 250 microns. Close valve to vacuum pump and watch rate of rise. If vacuum does not rise above 1500 microns in three to five minutes, system can be considered properly evacuated.
6. If thermocouple vacuum gauge continues to rise and levels off at about 5000 microns, moisture and non-condensables are still present. If gauge continues to rise a leak is present. Repair and re-evacuate.
7. Close valve to thermocouple vacuum gauge and vacuum pump. Shut off pump and prepare to charge.

## S-103 CHARGING



### WARNING

#### REFRIGERANT UNDER PRESSURE!

- \* Do not overcharge system with refrigerant.
  - \* Do not operate unit in a vacuum or at negative pressure.
- Failure to follow proper procedures may cause property damage, personal injury or death.



### CAUTION

Use refrigerant certified to ARI standards. Used refrigerant may cause compressor damage and will void the warranty. Most portable machines cannot clean used refrigerant to meet ARI standards.



### CAUTION

Operating the compressor with the suction valve closed will void the warranty and cause serious compressor damage.

Charge the system with the exact amount of refrigerant.

Refer to the specification section or check the unit nameplates for the correct refrigerant charge.

***An inaccurately charged system will cause future problems.***

1. When using an ambient compensated calibrated charging cylinder, allow liquid refrigerant only to enter the high side.
2. After the system will take all it will take, close the valve on the high side of the charging manifold.
3. Start the system and charge the balance of the refrigerant through the low side. DO NOT charge in a liquid form.
4. With the system still running, close the valve on the charging cylinder. At this time, you may still have some liquid refrigerant in the charging cylinder hose and will definitely have liquid in the liquid hose. Reseat the liquid line core. Slowly open the high side manifold valve and transfer the liquid refrigerant from the liquid line hose and charging cylinder hose into the suction service valve port. CAREFUL: Watch so that liquid refrigerant does not enter the compressor.
5. With the system still running, reseal the suction valve core, remove hose and reinstall both valve core caps.
6. Check system for leaks.

# SERVICING

**NOTE: This charging procedure can only be done in the cooling mode of operation. (Early production "a" models only.) All models with compressor process tube access valve can be processed in heating cycle if this valve is used.**

When charging a remote condensing unit with a non-matching evaporator coil, or a system where the charge quantity is unknown, alternate charging methods must be used. These systems must be charged according to subcooling or superheat.

SYSTEM SUPERHEAT					
Ambient Condenser Inlet Temp. (°F Drybulb)	Return Air Temperature (°F Drybulb)				
	65	70	75	80	85
115					3
100				5	5
95			5	5	5
90			7	12	18
85		5	10	17	20
80		5	12	21	26
75	5	10	17	25	29
70	5	14	20	28	32
65	13	19	26	32	35
60	17	25	30	33	37

Coils having flow control restrictors should be charged to match the System Superheat chart above. Coils with thermostatic expansion valves (TXV's) should be charged by subcooling. See "Checking Subcooling and Superheat" sections in this manual.

Due to their design, Scroll compressors are inherently more tolerant of liquid refrigerant.

**NOTE:** Even though the compressor section of a Scroll compressor is more tolerant of liquid refrigerant, continued floodback or flooded start conditions may wash oil from the bearing surfaces causing premature bearing failure.

If a restriction is located, replace the restricted part, replace drier, evacuate and recharge.

## S-104 CHECKING COMPRESSOR EFFICIENCY

The reason for compressor inefficiency is broken or damaged suction and/or discharge valves, or scroll flanks on Scroll compressors, reducing the ability of the compressor to pump refrigerant vapor.

The condition of the valves or scroll flanks is checked in the following manner.

1. Attach gauges to the high and low side of the system.

2. Start the system and run a "Cooling Performance Test. If the test shows:

- a. Below normal high side pressure.
- b. Above normal low side pressure.
- c. Low temperature difference across coil.
- d. Low amp draw at compressor.

and the charge is correct. The compressor is faulty - replace the compressor. **NOTE: THIS TEST CANNOT BE DONE IN THE HEATING MODE**

Verification of proper rotation of Scroll Compressors is made as follows.

**NOTE:** The compressor may run backwards (noisy operation) for 1 or 2 seconds at shutdown. This is normal and does not harm the compressor.

1. Install gauges and verify that the suction pressure drops while the discharge pressure increases.
2. Listen for normal compressor sound levels. Reverse rotation results in elevated or unusual sound levels.
3. Reverse rotation will result in substantially reduced amp draw from tabulated values.

To correct improper rotation, switch any two power supply leads at the outdoor unit contactor.

The 3 phase Scroll Compressors are direction of rotation sensitive. They will rotate in either direction depending on the phasing of the power. There is no negative impact on durability caused by operating 3 phase compressors in reversed rotation. The compressors internal protector will trip, de-energizing the compressor. Continued operation of 3 phase scroll compressors with the rotation reversed will contribute to compressor failure. All 3 phase scroll compressors should be checked for correct phase rotation.

## S-105B THERMOSTATIC EXPANSION VALVE

The expansion valve is designed to control the rate of liquid refrigerant flow into an evaporator coil in exact proportion to the rate of evaporation of the refrigerant in the coil. The amount of refrigerant entering the coil is regulated since the valve responds to temperature of the refrigerant gas leaving the coil (feeler bulb contact) and the pressure of the refrigerant in the coil. This regulation of the flow prevents the return of liquid refrigerant to the compressor.

The illustration below shows typical heat pump TXV/check valve operation in the heating and cooling modes.

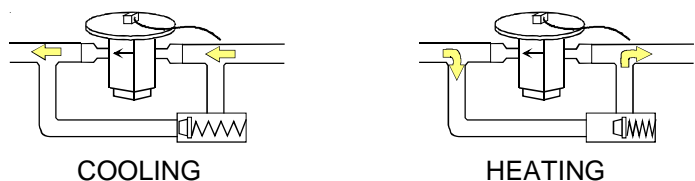

# SERVICING

## THERMOSTATIC EXPANSION VALVES

Some TXV valves contain an internal check valve thus eliminating the need for an external check valve and bypass loop. The three forces which govern the operation of the valve are: (1) the pressure created in the power assembly by the feeler bulb, (2) evaporator pressure, and (3) the equivalent pressure of the superheat spring in the valve.

0% bleed type expansion valves are used on indoor and outdoor coils. The 0% bleed valve will not allow the system pressures (High and Low side) to equalize during the shut down period. The valve will shut off completely at approximately 100 PSIG.

30% bleed valves used on some other models will continue to allow some equalization even though the valve has shut-off completely because of the bleed holes within the valve. This type of valve should not be used as a replacement for a 0% bleed valve, due to the resulting drop in performance.

The bulb must be securely fastened with two straps to a clean straight section of the suction line. Application of the bulb to a horizontal run of line is preferred. If a vertical installation cannot be avoided, the bulb must be mounted so that the capillary tubing comes out at the top.

**THE VALVES PROVIDED BY GOODMAN ARE DESIGNED TO MEET THE SPECIFICATION REQUIREMENTS FOR OPTIMUM PRODUCT OPERATION. DO NOT USE SUBSTITUTES.**

## S-106 OVERFEEDING

Overfeeding by the expansion valve results in high suction pressure, cold suction line, and possible liquid slugging of the compressor.

If these symptoms are observed:

1. Check for an overcharged unit by referring to the cooling performance charts in the servicing section.
2. Check the operation of the power element in the valve as explained in S-110 Checking Expansion Valve Operation.
3. Check for restricted or plugged equalizer tube.

## S-107 UNDERFEEDING

Underfeeding by the expansion valve results in low system capacity and low suction pressures.

If these symptoms are observed:

1. Check for a restricted liquid line or drier. A restriction will be indicated by a temperature drop across the drier.
2. Check the operation of the power element of the valve as described in S-110 Checking Expansion Valve Operation.

## S-108 SUPERHEAT

The expansion valves are factory adjusted to maintain 12 to 18 degrees superheat of the suction gas. Before checking the superheat or replacing the valve, perform all the procedures outlined under Air Flow, Refrigerant Charge, Expansion Valve - Overfeeding, Underfeeding. These are the most common causes for evaporator malfunction.

## CHECKING SUPERHEAT

Refrigerant gas is considered superheated when its temperature is higher than the saturation temperature corresponding to its pressure. The degree of superheat equals the degrees of temperature increase above the saturation temperature at existing pressure. See Temperature - Pressure Chart Table 7.

1. Attach an accurate thermometer or preferably a thermocouple type temperature tester to the suction line at a point at least 6" from the compressor.
2. Install a low side pressure gauge on the suction line service valve at the outdoor unit.
3. Record the gauge pressure and the temperature of the line.
4. Convert the suction pressure gauge reading to temperature by finding the gauge reading in Temperature - Pressure Chart and reading to the left, find the temperature in the °F. Column.
5. The difference between the thermometer reading and pressure to temperature conversion is the amount of superheat.

### EXAMPLE:

- a. Suction Pressure = 84
- b. Corresponding Temp. °F. = 50
- c. Thermometer on Suction Line = 63°F.

To obtain the degrees temperature of superheat subtract 50.0 from 63.0°F.

The difference is 13° Superheat. The 13° Superheat would fall in the ± range of allowable superheat.

## SUPERHEAT ADJUSTMENT

The expansion valves used on Amana® coils are factory set and are not field adjustable. If the superheat setting becomes disturbed, replace the valve.

On systems using capillary tubes or flow control restrictors, superheat is adjusted in accordance with the "DESIRED SUPERHEAT vs. OUTDOOR TEMP" chart as explained in section S-103 CHARGING



# SERVICING

Temp. °F.	Gauge Pressure (PSIG) Freon-22	Temp. °F.	Gauge Pressure (PSIG) Freon-22
-40	0.61	60	102.5
-38	1.42	62	106.3
-36	2.27	64	110.2
-34	3.15	65	114.2
-32	4.07	68	118.3
-30	5.02	70	122.5
-28	6.01	72	126.8
-26	7.03	74	131.2
-24	8.09	76	135.7
-22	9.18	78	140.5
-20	10.31	80	145.0
-18	11.48	82	149.5
-16	12.61	84	154.7
-14	13.94	86	159.8
-12	15.24	88	164.9
-10	16.59	90	170.1
-8	17.99	92	175.4
-6	19.44	94	180.9
-4	20.94	96	186.5
-2	22.49	96	192.1
0	24.09	100	197.9
2	25.73	102	203.8
4	27.44	104	209.9
6	29.21	106	216.0
8	31.04	108	222.3
10	32.93	110	228.7
12	34.88	112	235.2
14	36.89	114	241.9
16	38.96	116	248.7
18	41.09	118	255.6
20	43.28	120	262.6
22	45.53	122	269.7
24	47.85	124	276.9
26	50.24	126	284.1
28	52.70	128	291.4
30	55.23	130	298.8
32	57.83	132	306.3
34	60.51	134	314.0
36	63.27	136	321.9
38	66.11	136	329.9
40	69.02	140	338.0
42	71.99	142	346.3
44	75.04	144	355.0
46	78.18	146	364.3
48	81.40	158	374.1
50	84.70	150	384.3
52	88.10	152	392.3
54	91.5	154	401.3
56	95.1	156	411.3
58	98.8	158	421.8
		160	433.3

Table 7

## S-109 CHECKING SUBCOOLING

Refrigerant liquid is considered subcooled when its temperature is lower than the saturation temperature corresponding to its pressure. The degree of subcooling equals the degrees of temperature decrease below the saturation temperature at the existing pressure.

1. Attach an accurate thermometer or preferably a thermocouple type temperature tester to the liquid line as it leaves the condensing unit.
2. Install a high side pressure gauge on the high side (liquid) service valve at the front of the unit.
3. Record the gauge pressure and the temperature of the line.
4. Convert the liquid line pressure gauge reading to temperature by finding the gauge reading in Temperature - Pressure Chart and reading to the left, find the temperature in the °F. Column.
5. The difference between the thermometer reading and pressure to temperature conversion is the amount of subcooling.

### EXAMPLE:

- a. Liquid Line Pressure = 260
- b. Corresponding Temp. °F. = 120°
- c. Thermometer on Liquid line = 109°F.

To obtain the amount of subcooling subtract 109°F from 120°F.

The difference is 11° subcooling. The normal subcooling range is 9° - 13° subcooling for heat pumps units, 14 to 18 for straight cool units.

## S-110 CHECKING EXPANSION VALVE OPERATION

1. Remove the remote bulb of the expansion valve from the suction line.
2. Start the system and cool the bulb in a container of ice water, closing the valve. As you cool the bulb, the suction pressure should fall and the suction temperature will rise.
3. Next warm the bulb in your hand. As you warm the bulb, the suction pressure should rise and the suction temperature will fall.
4. If a temperature or pressure change is noticed, the expansion valve is operating. If no change is noticed, the valve is restricted, the power element is faulty, or the equalizer tube is plugged.
5. Capture the charge, replace the valve and drier, evacuate and recharge.

# SERVICING

## S-111 CAPILLARY TUBES/RESTRICTOR ORIFICES

The capillary tubes/restrictor orifices used in conjunction with the indoor and outdoor coil, are a predetermined length and bore (I.D.).

They are designed to control the rate of liquid refrigerant flow into an evaporator coil.

The amount of refrigerant that flows through the capillary tube/restrictor orifice is regulated by the pressure difference between the high and low sides of the system.

In the cooling cycle when the outdoor air temperature rises, the high side condensing pressure rises. At the same time, the cooling load on the indoor coil increases, causing the low side pressure to rise, but at a slower rate.

Since the high side pressure rises faster when the temperature increases, more refrigerant flows to the evaporator, increasing the cooling capacity of the system.

When the outdoor temperature falls, the reverse takes place. The condensing pressure falls, and the cooling loads on the indoor coil decrease, causing less refrigerant flow.

A strainer is placed on the entering side of the tubes to prevent any foreign material from becoming lodged inside the capillary tubes.

If a restriction should become evident, proceed as follows:

1. Capture the refrigerant charge.
2. Remove the capillary tubes/restrictor orifice or tube strainer assembly. and replace.
3. Replace liquid line drier, evacuate and recharge.



**Capillary Tubes/Orifice Assembly**

### CHECKING EQUALIZATION TIME

During the "OFF" cycle, the high side pressure bleeds to the low side through the capillary tubes/restrictor orifices. Check equalization time as follows:

1. Attach a gauge manifold to the suction and liquid line dill valves.
2. Start the system and allow the pressures to stabilize.
3. Stop the system and check the time it takes for the high and low pressure gauge readings to equalize.

If it takes more than seven (7) minutes the capillary tubes/restrictor orifices are inoperative. Replace, install a liquid line drier, evacuate and recharge.

## S-112 CHECKING RESTRICTED LIQUID LINE

When the system is operating, the liquid line is warm to the touch. If the liquid line is restricted, a definite temperature drop will be noticed at the point of restriction. In severe cases, frost will form at the restriction and extend down the line in the direction of the flow.

Discharge and suction pressures will be low, giving the appearance of an undercharged unit. However, the unit will have normal to high subcooling.

Locate the restriction, replace the restricted part, replace drier, evacuate and recharge.

## S-113 OVERCHARGE OF REFRIGERANT

An overcharge of refrigerant is normally indicated by an excessively high head pressure.

An evaporator coil, using an expansion valve metering device, will basically modulate and control a flooded evaporator and prevent liquid return to the compressor.

An evaporator coil, using a capillary tube metering device, could allow refrigerant to return to the compressor under extreme overcharge conditions. Also with a capillary tube metering device, extreme cases of insufficient indoor air can cause icing of the indoor coil and liquid return to the compressor, but the head pressure would be lower.

There are other causes for high head pressure which may be found in the "Service Problem Analysis Guide."

If other causes check out normal, an overcharge or a system containing non-condensables would be indicated.

If this system is observed:

1. Start the system.
2. Remove and capture small quantities of gas from the suction line dill valve until the head pressure is reduced to normal.
3. Observe the system while running a cooling performance test. If a shortage of refrigerant is indicated, then the system contains non-condensables.

## S-114 NON-CONDENSABLES

If non-condensables are suspected, shut down the system and allow the pressures to equalize. Wait at least 15 minutes. Compare the pressure to the temperature of the coldest coil since this is where most of the refrigerant will be. If the pressure indicates a higher temperature than that of the coil temperature, non-condensables are present.

Non-condensables are removed from the system by first removing the refrigerant charge, replacing and/or installing liquid line drier, evacuating and recharging.



# SERVICING

## S-115 COMPRESSOR BURNOUT

When a compressor burns out, high temperature develops causing the refrigerant, oil and motor insulation to decompose forming acids and sludge.

If a compressor is suspected of being burned-out, attach a refrigerant hose to the liquid line dill valve and properly remove and dispose of the refrigerant.



### NOTICE

**Violation of EPA regulations may result in fines or other penalties.**

Now determine if a burn out has actually occurred. Confirm by analyzing an oil sample using a Sporlan Acid Test Kit, AK-3 or its equivalent.

Remove the compressor and obtain an oil sample from the suction stub. If the oil is not acidic, either a burnout has not occurred or the burnout is so mild that a complete clean-up is not necessary.

If acid level is unacceptable, the system must be cleaned by using the clean-up drier method.



### CAUTION

**Do not allow the sludge or oil to contact the skin. Severe burns may result.**

**NOTE:** The Flushing Method using R-11 refrigerant is no longer approved by Goodman Company, L.P.

### Suction Line Drier Clean-Up Method

Use AMANA® part number RF000127 suction line filter drier kit. This drier should be installed as close to the compressor suction fitting as possible. The filter must be accessible and be rechecked for a pressure drop after the system has operated for a time. It may be necessary to use new tubing and form as required.

**NOTE:** At least twelve (12) inches of the suction line immediately out of the compressor stub must be discarded due to burned residue and contaminates.

1. Remove compressor discharge line strainer.
2. Remove the liquid line drier and expansion valve.
3. Purge all remaining components with dry nitrogen or carbon dioxide until clean.
4. Install new components **including** liquid line drier.
5. Braze all joints, leak test, evacuate, and recharge system.
6. Start up the unit and record the pressure drop across the drier.
7. Continue to run the system for a minimum of twelve (12) hours and recheck the pressure drop across the drier. Pressure drop should not exceed 6 PSIG.

8. Continue to run the system for several days, repeatedly checking pressure drop across the suction line drier. If the pressure drop never exceeds the 6 PSIG, the drier has trapped the contaminants. Remove the suction line drier from the system.
9. If the pressure drop becomes greater, then it must be replaced and steps 5 through 9 repeated until it does not exceed 6 PSIG.

**NOTICE:** Regardless, the cause for burnout must be determined and corrected before the new compressor is started.

## S-120 REFRIGERANT PIPING

The piping of a refrigeration system is very important in relation to system capacity, proper oil return to compressor, pumping rate of compressor and cooling performance of the evaporator.

This long line set application guideline applies to all ARI listed R22 air conditioner and heat pump split system matches of nominal capacity 18,000 to 60,000 Btuh. This guideline will cover installation requirements and additional accessories needed for split system installations where the line set exceeds 50 feet in actual length.

### Additional Accessories:

1. **Crankcase Heater-** a long line set application can critically increase the charge level needed for a system. As a result, the system is very prone to refrigerant migration during its off-cycle and a crankcase heater will help minimize this risk. A crankcase heater is recommended for any long line application (50 watt minimum).
2. **TXV Requirement:** All line set applications over 50 ft will require a TXV.
3. **Hard Start Assist-** increased charge level in long line applications can require extra work from the compressor at start-up. A hard start assist device may be required to overcome this.
4. **Liquid Line Solenoid -** A long line set application can critically increase the charge level needed for a system. As a result, the system is very prone to refrigerant migration during its off-cycle and a liquid line solenoid will help minimize this. A liquid line solenoid is recommended for any long line application on straight cooling units.

### Tube Sizing:

1. In long line applications, the "equivalent line length" is the sum of the straight length portions of the suction line plus losses (in equivalent length) from 45 and 90 degree bends. **Select the proper suction tube size based on equivalent length of the suction line (see Tables 8 & 9) and recalculated system capacity.**

Equivalent length = Length horizontal + Length vertical + Losses from bends (see Table 9)

# SERVICING

- For any residential split system installed with a long line set, the liquid line size must never exceed 3/8". Limiting the liquid line size to 3/8" is critical since an increased refrigerant charge level from having a larger liquid line could possibly shorten a compressor's lifespan.
- Single Stage Condensing Unit:** The maximum length of tubing must not exceed 150 feet.
  - 50 feet** is the maximum recommended vertical difference between the condenser and evaporator when the evaporator is above the condenser. Equivalent length is not to exceed 150 feet.
  - The vertical difference between the condenser and evaporator when the evaporator is below the condenser can approach 150 feet, as long as the equivalent length does not exceed 150 feet.
  - The distance between the condenser and evaporator in a completely horizontal installation in which the indoor and outdoor unit do not differ more than 10 feet in vertical distance from each other can approach 150 feet, as long as the equivalent length does not exceed 150 feet.
- Two-Stage Condensing Unit:** The maximum length of tubing must not exceed 75 feet here indoor coil is located above the outdoor unit.

**NOTE:** When the outdoor unit is located above the indoor coil, the maximum vertical rise must not exceed 25 feet. If the maximum vertical rise exceeds 25 feet, premature compressor failure will occur due to inadequate oil return.

- Vibration and Noise:** In long line applications, refrigerant tubing is highly prone to transmit noise and vibration to the structure it is fastened to. Use adequate vibration-isolating hardware when mounting line set to adjacent structure.

Most refrigerant tubing kits are supplied with 3/8"-thick insulation on the vapor line. For long line installations over 50 feet, especially if the line set passes through a high ambient temperature, 1/2"-thick suction line insulation is recommended to reduce loss of capacity. The liquid line should be insulated if passing through an area of 120°F or greater. Do not attach the liquid line to any non-insulated portion of the suction line

Table 8 lists multiplier values to recalculate system-cooling capacity as a function of a system's equivalent line length (as calculated from the suction line) and the selected suction tube size. Table 2 lists the equivalent length gained from adding bends to the suction line. **Properly size the suction line to minimize capacity loss.**

REFRIGERANT LINE LENGTH (Ft)						
Cond Unit Tons	0-24		25-49		50-74***	
	Line Diameter (In. OD)					
	Suct	Liq	Suct	Liq	Suct	Liq
1 1/2	5/8	1/4	3/4	3/8	3/4	3/8
2	5/8	1/4	3/4	3/8	3/4	3/8
2 1/2	3/4	3/8	3/4*	3/8	7/8	3/8
3	3/4	3/8	3/4**	3/8	7/8**	3/8
3 1/2	3/4	3/8	7/8**	3/8	1 1/8	3/8
4	7/8	3/8	1 1/8	3/8	1 1/8	3/8
5	7/8	3/8	1 1/8	3/8	1 1/8	3/8

\*7/8" required for full ratings

\*\*1 1/8" required for full ratings

\*\*\*Lines greater than 74 feet in length or vertical elevation changes more than 50 feet, refer to the long line set.

TABLE 8. CAPACITY MULTIPLIERS AS A FUNCTION OF SUCTION LINE SIZE & EQUIVALENT LENGTH

Nominal capacity Btuh	Vapor line diameter (in.)	EQUIVALENT LINE LENGTH (FT)				
		50	75	100	125	150
18,000	3/4	.99	.97	.96	.95	.95
24,000	3/4	1	.99	.99	.98	.97
30,000	3/4	.98	.97	.96	.95	.94
36,000	3/4	.93	.90	.86	.83	.79
	7/8	.98	.96	.94	.92	.90
42,000	3/4	.93	.90	.87	.83	.80
	7/8	.97	.96	.94	.93	.92
	1-1/8	1	1	.99	.99	.98
48,000	3/4	.90	.86	.82	.78	N/R
	7/8	.96	.94	.93	.91	.89
	1-1/8	1	1	.99	.99	.98
60,000	7/8	.93	.91	.89	.86	.84
	1-1/8	.99	.98	.98	.97	.97

Table 8

**NOTE:** For a condenser with a liquid valve tube connection less than 3/8" diameter, use 3/8" liquid line tubing for a line set greater than 25 feet.

TABLE 9. LOSSES FROM SUCTION LINE ELBOWS (EQUIVALENT LENGTH, FT.)

Type of elbow fitting	I.D. (in.)		
	3/4	7/8	1-1/8
90° short radius	1.7	2	2.3
90° long radius	1.5	1.7	1.6
45°	0.7	0.8	1

Table 9

## Installation Requirements

- In a completely horizontal installation with a long line set where the evaporator is at the same altitude as (or slightly below) the condenser, the line set should be sloped towards the evaporator. This helps reduce refrigerant migration to the condenser during a system's off-cycle.

# SERVICING

- For a system installation where the evaporator is above the condenser, an inverted vapor line trap should be installed on the suction line just before the inlet to the evaporator (see Fig 6). The top of the inverted loop must be slightly above the top of the evaporator coil and can be created simply by brazing two 90° long radius elbows together, if a bending tool is unavailable. Properly support and secure the inverted loop to the nearest point on the indoor unit or adjacent structure.

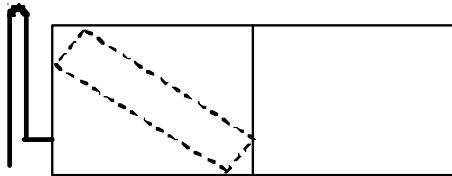

Fig 6. Evaporator unit with inverted vapor loop

- An oil trap is required at the evaporator only if the condenser is above the evaporator.** Preformed oil traps are available at most HVAC supply houses, or oil traps may be created by brazing tubing elbows together (see diagram below). Remember to add the equivalent length from oil traps to the equivalent length calculation of the suction line. For example, if you construct an oil trap using two 45° elbows, one short and one long 90° elbow in a 3/4" diameter suction line, the additional equivalent length would be 0.7+ 0.7+1.7+1.5, which equals 4.6 feet (refer to table 9).

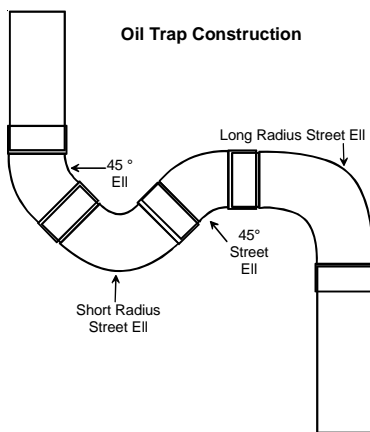

Fig 7. Oil Trap

- Low voltage wiring.** Verify low voltage wiring size is adequate for the length used since it will be increased in a long line application.

## System Charging

R22 condensers are factory charged for 15 feet of line set. To calculate the amount of extra refrigerant (in ounces) needed for a line set over 15 feet, multiply the additional length of line set by 0.6 ounces. Note for the formula below, the linear feet of line set is the actual length of liquid line (or suction line, since both should be equal) used, not the equivalent length calculated for the suction line.

$$\text{Extra refrigerant needed} = (\text{Linear feet of line set} - 15 \text{ ft}) \times X \text{ oz/ft.}$$

Where **X = 0.6** for 3/8" liquid tubing

Remember, for condensers with a liquid valve connection less than 3/8" diameter, 3/8" liquid tubing is required for a line set longer than 25 feet.

Follow the charging procedures in the outdoor unit I/O manual to ensure proper superheat and sub-cooling levels, especially on a system with a TXV installed in the indoor unit. Heat pumps should be checked in both heating and cooling mode for proper charge level. This guideline is meant to provide installation instructions based on most common long line set applications. Installation variables may affect system operation.

**NO ADDITIONAL COMPRESSOR OIL IS NEEDED FOR LONG LINE SET APPLICATIONS ON RESIDENTIAL SPLIT SYSTEMS.**

## S-122 REVERSING VALVE REPLACEMENT

Remove the refrigerant charge from the system.

When brazing a reversing valve into the system, it is of extreme importance that the temperature of the valve **does not exceed 250° F.** at any time.

Wrap the reversing valve with a large rag saturated with water. "Re-wet" the rag and thoroughly cool the valve after each brazing operation of the four joints involved. The wet rag around the reversing valve will eliminate conducting of heat to the valve body when brazing the line connection.

The use of a wet rag sometimes can be a nuisance. There are commercial grades of heat absorbing paste that may be substituted.

After the valve has been installed leak test, evacuate and recharge.

# SERVICING

## S-202 DUCT STATIC PRESSURES AND/OR STATIC PRESSURE DROP ACROSS COILS

This minimum and maximum allowable duct static pressure for the indoor sections are found in the specifications section.

Tables are also provided for each coil, listing quantity of air (CFM) versus static pressure drop across the coil.

Too great an external static pressure will result in insufficient air that can cause icing of the coil. Too much air can cause poor humidity control and condensate to be pulled off the evaporator coil causing condensate leakage. Too much air can also cause motor overloading and in many cases this constitutes a poorly designed system.

### S-203 AIR HANDLER EXTERNAL STATIC

To determine proper air movement, proceed as follows:

1. Using a draft gauge (inclined manometer), measure the static pressure of the return duct at the inlet of the unit, (Negative Pressure).
2. Measure the static pressure of the supply duct, (Positive Pressure).
3. Add the two readings together.

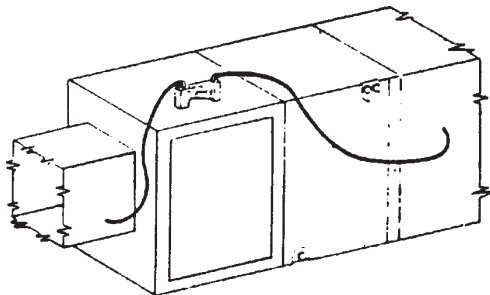

**TOTAL EXTERNAL STATIC**

**NOTE:** Both readings may be taken simultaneously and read directly on the manometer if so desired.

4. Consult proper table for quantity of air.

If external static pressure is being measured on a furnace to determine airflow, supply static must be taken between the "A" coil and the furnace.

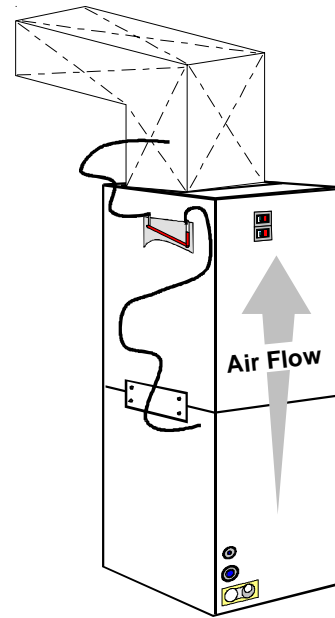

**TOTAL EXTERNAL STATIC**

### S-204 COIL STATIC PRESSURE DROP

1. Using a draft gauge (inclined manometer), connect the positive probe underneath the coil and the negative probe above the coil.
2. A direct reading can be taken of the static pressure drop across the coil.
3. Consult proper table for quantity of air.

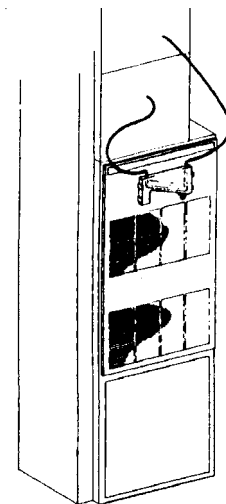

**STATIC PRESSURE DROP**

If the total external static pressure and/or static pressure drop exceeds the maximum or minimum allowable statics, check for closed dampers, dirty filters, undersized or poorly laid out duct work.

# ACCESSORIES WIRING DIAGRAMS



**WARNING**

**HIGH VOLTAGE!**  
**DISCONNECT ALL POWER BEFORE SERVICING OR INSTALLING THIS UNIT. MULTIPLE POWER SOURCES MAY BE PRESENT. FAILURE TO DO SO MAY CAUSE PROPERTY DAMAGE, PERSONAL INJURY OR DEATH.**



## ALL FUEL SYSTEM AFE18-60A CONTROL BOARD

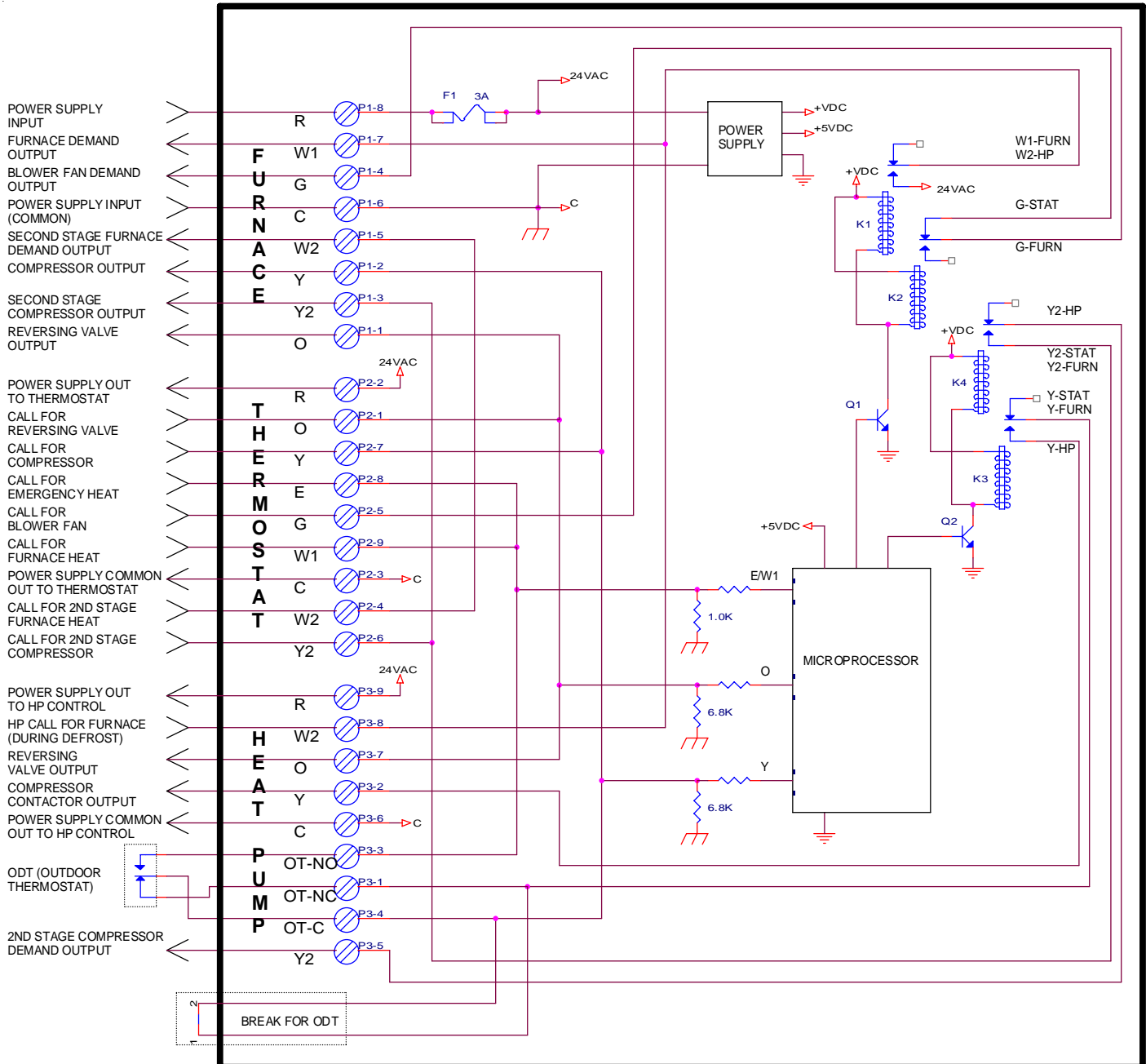

### ALL FUEL SYSTEM CONTROL BOARD - AFE18-60A

This wiring diagram is for reference only. Not all wiring is as shown above.

Refer to the appropriate wiring diagram for the unit being serviced.

(For use with Heat Pumps in conjunction with 80% or 90% Single-Stage or Two-Stage Furnaces)

# ACCESSORIES WIRING DIAGRAMS

**WARNING**

**HIGH VOLTAGE!**  
DISCONNECT ALL POWER BEFORE SERVICING OR INSTALLING THIS UNIT. MULTIPLE POWER SOURCES MAY BE PRESENT. FAILURE TO DO SO MAY CAUSE PROPERTY DAMAGE, PERSONAL INJURY OR DEATH.

## 10kw and Below, One Stage Electric Heat

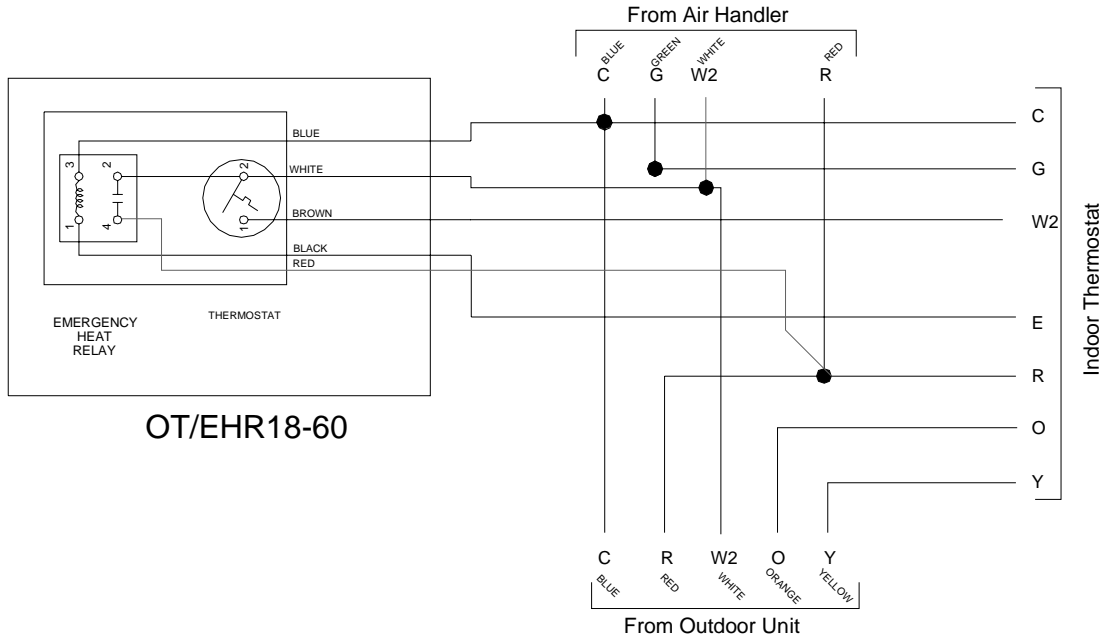

## 15kw and Above, Two Stage Electric Heat

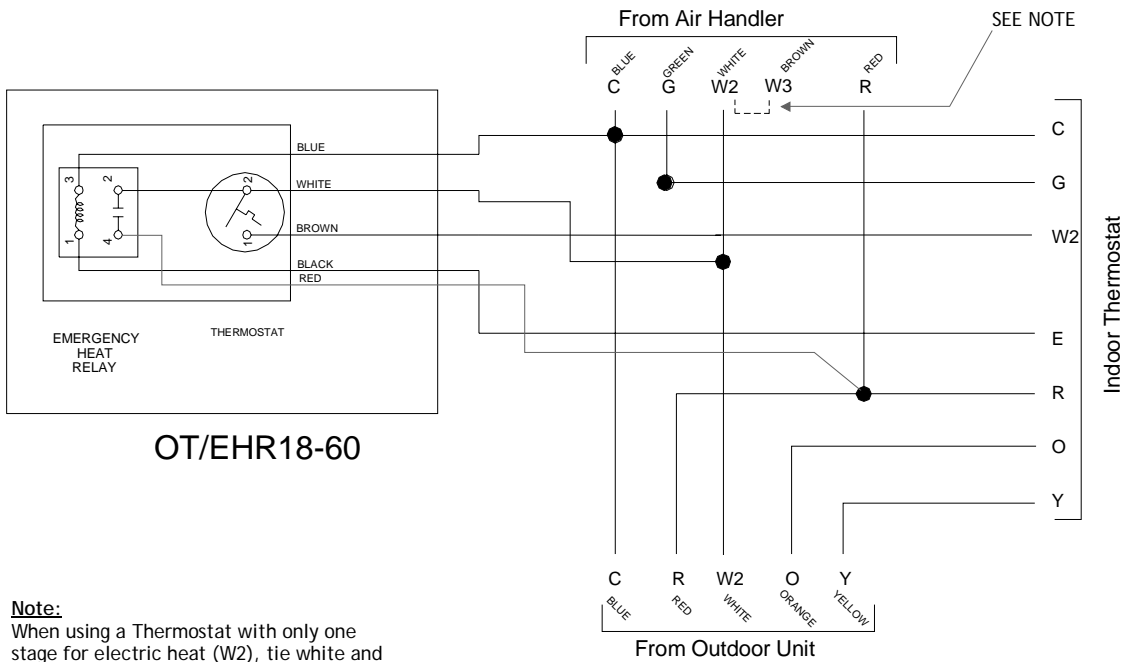

**Note:**

When using a Thermostat with only one stage for electric heat (W2), tie white and brown wires from air handler together.

Typical Wiring Schematics for OT/EHR18-60 (Outdoor Thermostat & Emergency Heat Relay).

This wiring diagram is for reference only. Not all wiring is as shown above.

Refer to the appropriate wiring diagram for the unit being serviced.

# ACCESSORIES WIRING DIAGRAMS



**WARNING**

**HIGH VOLTAGE!**  
DISCONNECT ALL POWER BEFORE SERVICING OR INSTALLING THIS UNIT. MULTIPLE POWER SOURCES MAY BE PRESENT. FAILURE TO DO SO MAY CAUSE PROPERTY DAMAGE, PERSONAL INJURY OR DEATH.



15kw and Above with Two OT/EHR18-60's, Two Stage Electric Heat and Two Stage Thermostat

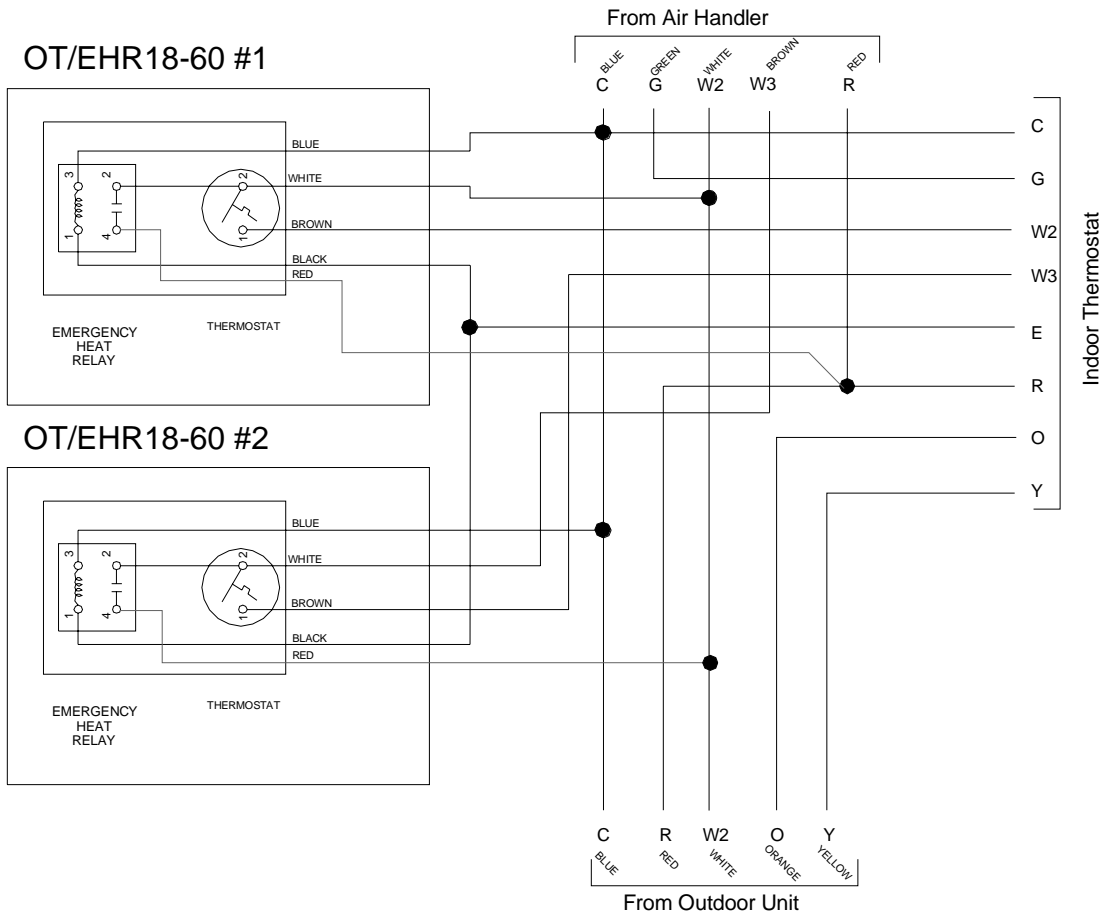

Typical Wiring Schematics for OT/EHR18-60 (Outdoor Thermostat & Emergency Heat Relay).  
This wiring diagram is for reference only. Not all wiring is as shown above.  
Refer to the appropriate wiring diagram for the unit being serviced.



# ACCESSORIES WIRING DIAGRAMS



**WARNING**

**HIGH VOLTAGE!**  
**DISCONNECT ALL POWER BEFORE SERVICING OR INSTALLING THIS UNIT. MULTIPLE POWER SOURCES MAY BE PRESENT. FAILURE TO DO SO MAY CAUSE PROPERTY DAMAGE, PERSONAL INJURY OR DEATH.**



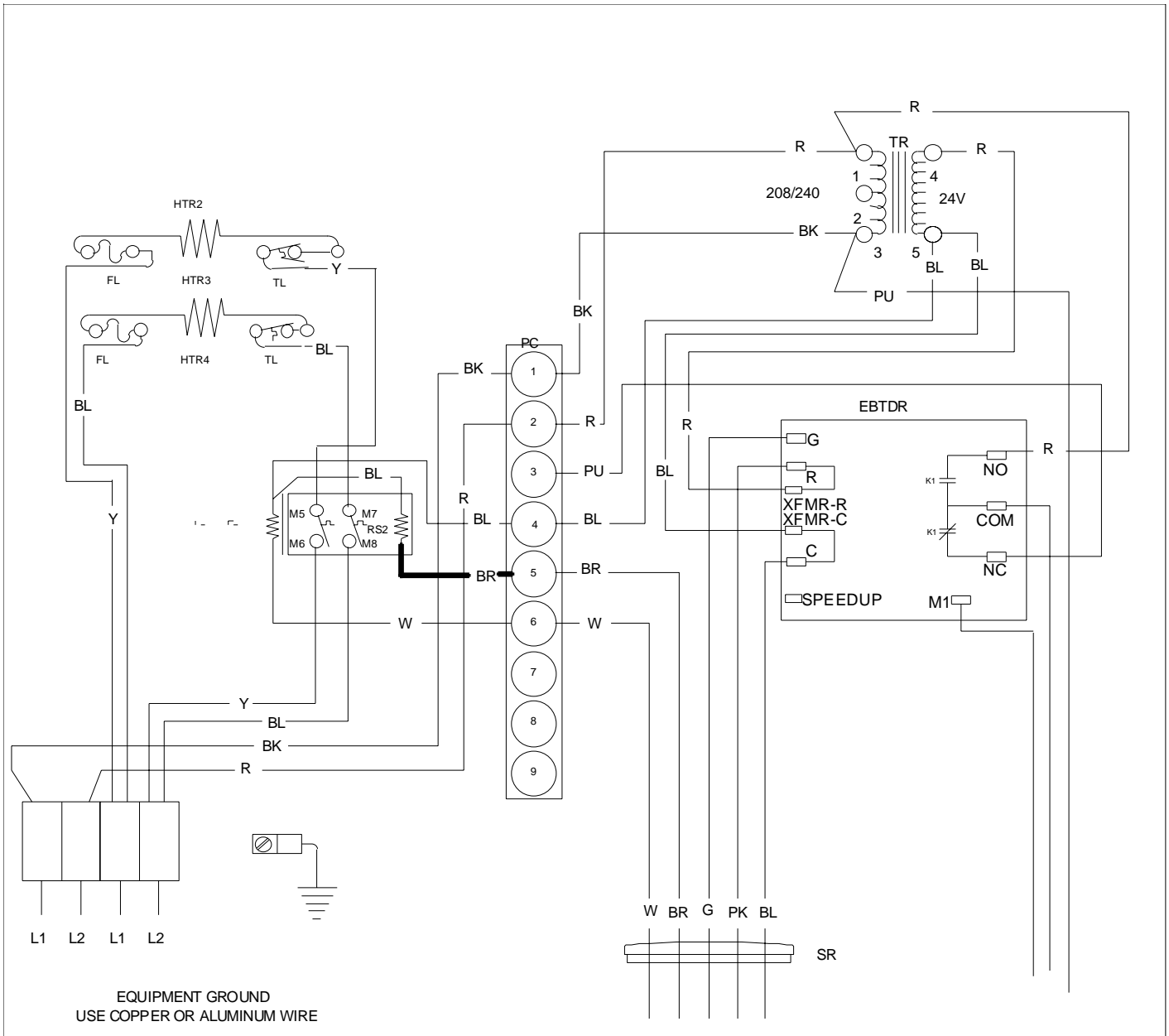

Typical Wiring Schematic MBR Blower with Electric Heat.  
 This wiring diagram is for reference only. Not all wiring is as shown above.  
 Refer to the appropriate wiring diagram for the unit being serviced.

# ACCESSORIES WIRING DIAGRAMS

**WARNING**

**HIGH VOLTAGE!**  
 DISCONNECT ALL POWER BEFORE SERVICING OR INSTALLING THIS UNIT. MULTIPLE POWER SOURCES MAY BE PRESENT. FAILURE TO DO SO MAY CAUSE PROPERTY DAMAGE, PERSONAL INJURY OR DEATH.

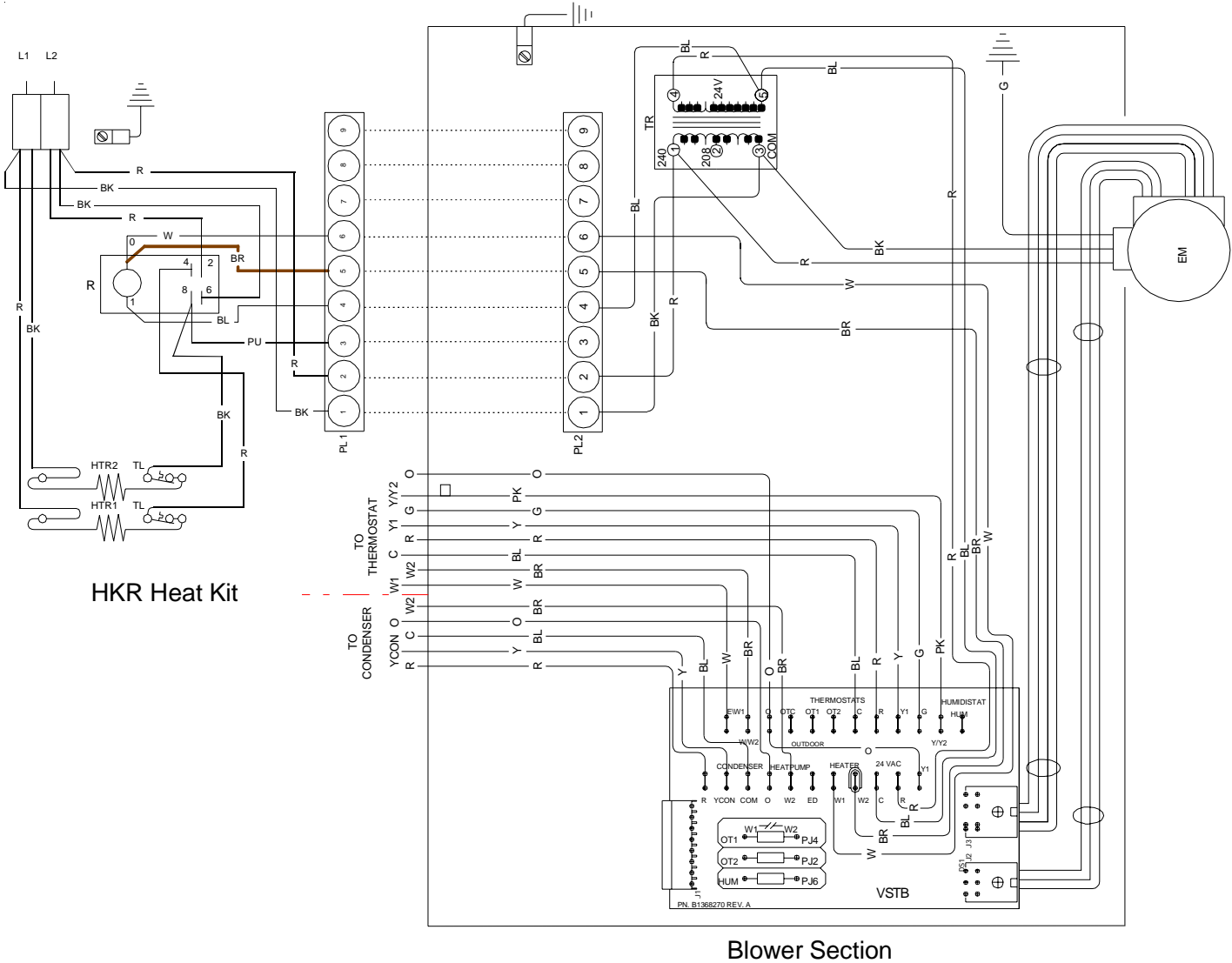

Typical Wiring Schematic MBE Blower with Electric Heat.  
 This wiring diagram is for reference only.  
 Not all wiring is as shown above.  
 Refer to the appropriate wiring diagram for the unit being serviced.