

alpha **9500ML**
Electronic Cash Management System

ROYAL

alpha

9500ML

Cash Management System

Instruction Manual

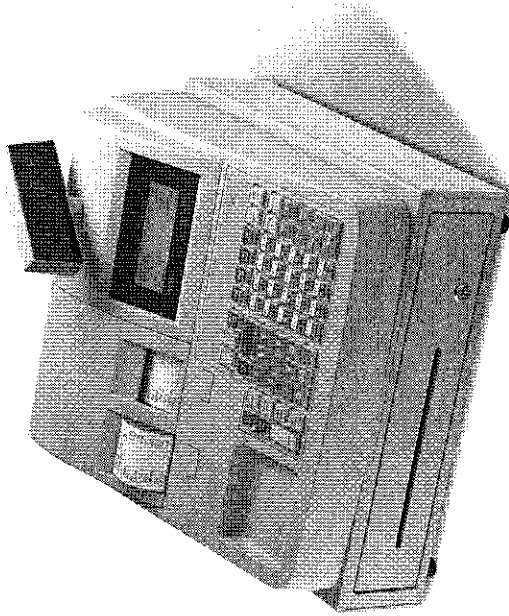

© Copyright
Royal Consumer Information Products, Inc.
2006. All Rights Reserved.

9500MLm1106
Z1AE-1192X 0811

ROYAL
Consumer Information Products, Inc.
379 Campus Dr.
Somerset, NJ 08875
Made in China

WELCOME...

to the Royal family of fine business machines.
We sincerely hope you will enjoy the many benefits
of being associated with a distinguished product
name that has represented both quality and
customer satisfaction since 1905.

This electronic cash register is designed to help your business function smoothly by providing efficient register operations and accurate management reports. Start-up is quick and easy, yet there are many options that can be added and revised so that you can customize your operations for optimum productivity. Here are just a few of the register's many valuable features:

- Heavy-duty 2-station alphanumeric thermal printers provide both journal and receipt printouts.
- 4-Line alpha display allows for quick and easy setup and operation. Software based screen prompts walk you through many of the programming options.
- Alpha keyboard cuts programming time in half! Program your own store name and commercial message - 10 lines by 24 characters each.
- 200 departments allow you to categorize merchandise to be sold. Each department can be programmed with a 16 character description i.e., "Food", "Beverages", etc.
- 5000 Price Look-Up (PLU) settings allow for fast, accurate entry of an item and records the number of items sold.
- 40 clerk numbers monitor sales of individual employees.
- Automatic tax computation available for 4 different tax rates, including add-on(US), GST-PST(Canada) and VAT(Mexico).
- USB Port for connection with a PC, Barcode Scanner or USB-based flash drive.
- Periodic management reports provide up-to-date sales analysis, including mid-day, end-of-day, weekly or monthly totals.
- Memory protection(3xAA batteries) maintains financial records during power outage.

The ROYAL CONSUMER PRODUCT SUPPORT HOTLINE gives you the opportunity to call for start-up assistance and problem resolution or for ordering supplies.

Customer Service (in U.S.A.): 1-800-272-6229
Customer Service (in Canada): 1-888-266-9380
Customer Service (in Mexico): 01-800-849-4826
Ordering Supplies: 1-888-261-4555

Or visit our website for more information and troubleshooting at www.royal.com.

CHAPTER 1: WELCOME.....7-16

1.1 Unpacking your cash register and Set-up.....7

1.2 Initial Setup.....7

Getting to know your cash register.....8

Using this manual.....8

Main part names and functions.....9

Control Lock.....10

Printer Compartment.....10

About the Displays.....11

Installing the Paper Rolls.....11-12

Installing the Memory backup batteries.....12-13

Using the Keyboard.....13-15

Quick Start-Up Guide.....15-16

Before going to Register mode.....16

CHAPTER 2: ADVANCED PROGRAMMING.....17-49

2.1 Main Programming Menus.....17

Navigating the Programming Menus.....17

Setting Alphanumeric Descriptions.....18

Using Double Width Characters.....18-19

Other Programming Options.....19

Programming and using Clerks.....19-20

To Program a Clerk Name.....19-20

To Program a Clerk Passcode.....20

Using Clerks.....20

Setting Manager Passcodes.....21-22

To Program the X Passcode.....21

To Program the Z Passcode.....21

To Program the Training Passcode.....22

To Program the Programming (PROG) Passcode.....22

Using Manager Passcodes.....22

Programming the System Options.....22-26

To Program the Date.....23

To Program the Time.....23

To Program the Transaction Number.....23-24

To Program the Machine Number.....24

To Program the X1 Report Number.....24

To Program the X2 Report Number.....25

To Program the Z1 Report Number.....25-26

To Program the Z2 Report Number.....25

To Program the Cash Alarm.....26

Programming Departments.....26-28

To Program a Department Name.....26-27

To Program a Department Price.....27

To Program a Department Flags (Tax status and more).....27-28

Programming Price Look-ups(PLUs).....29-31

To Program a PLU number or barcode.....29

To Program a PLU name.....29-30

To Program a PLU price.....30

To Program a PLU linking department.....30

Barcode Learning Function.....30-31

Price Checker Function.....31

Programming Tax Rates.....31-32

Programming a Tax Type.....31

Programming a Tax Rate.....31-32

32	Programming the Tax limit.....
32-35	Programming a Tax Table or Canadian Tax rate.....
32	Calculating Breakpoints.....
33-34	Program Example.....
33-35	Entering a Calculated Tax Table.....
35	Programming a Canadian(GST-PST) Tax Rate.....
35-37	Programming Discounts, Add-ons, and Coupons.....
36	Programming the Plus Percentage(+%) Key.....
36-37	Programming the Minus Percentage(-%) Discount Key.....
37-38	Programming the Coupon Key.....
38-42	Programming System Configuration Options(Flags).....
42-43	Adjusting the Keyboard Layout.....
43-46	Programming the Transaction Words.....
46-47	Programming Headers and Footers.....
47-48	Programming the Foreign Currency (FC) Key.....
48	Programming a Journal Message.....
48-49	Updating the Cash Register Software.....
2.18	Updating the Cash Register Software.....
2.17	Programming a Journal Message.....
2.16	Programming the Foreign Currency (FC) Key.....
2.15	Programming Headers and Footers.....
2.14	Programming the Transaction Words.....
2.13	Adjusting the Keyboard Layout.....
2.12	Programming System Configuration Options(Flags).....
2.11	Programming Discounts, Add-ons, and Coupons.....
3.1	Printing / Running Dump Reports.....
3.2	Printing / Viewing X Reports.....
3.3	Printing and Clearing Z Reports.....
3.4	Saving Z Reports to a USB drive.....
50-51	Printing / Running Dump Reports.....
52-53	Printing / Viewing X Reports.....
53-57	Printing and Clearing Z Reports.....
57-58	Saving Z Reports to a USB drive.....
59	CHAPTER 4: TRAINING MODE.....
59	Entering / Exiting Training Mode.....
60-66	CHAPTER 5: TRANSACTION EXAMPLES.....
60	EXAMPLE 1: CASH SALES WITH CHANGE TENDERED.....
60	EXAMPLE 2: REGISTERING A SALES USING A DEPARTMENT KEY.....
60	EXAMPLE 3: CHECK SALE.....
60	EXAMPLE 4: CHARGE SALE.....
60	EXAMPLE 5: SPLIT TENDERING SALE.....
61	EXAMPLE 6: NO SALE FUNCTION.....
61	EXAMPLE 7: RINGING IN MULTIPLE ITEMS.....
61	EXAMPLE 8: USING THE QTY KEY.....
62	EXAMPLE 9: REPEATING A PLU ENTRY.....
62	EXAMPLE 10: EXEMPTING TAX ON AN ITEM.....
62	EXAMPLE 11: USING THE TAX FORCE FUNCTION.....
62	EXAMPLE 12: RECEIVED ON-ACCOUNT SALE.....
63	EXAMPLE 13: PAID-OUT SALE.....
63	EXAMPLE 14: RETURN MERCHANDISE SALE.....
63	EXAMPLE 15: VOIDING A SALES ENTRY.....
63	EXAMPLE 16: USING THE ERROR-CORRECT(EC) KEY.....
63	EXAMPLE 17: CANCELLING A TRANSACTION.....
64	EXAMPLE 18: APPLYING A COUPON DISCOUNT TO AN ITEM ENTRY.....
64	EXAMPLE 19: APPLYING A COUPON DISCOUNT TO AN ENTIRE SALE.....
64	EXAMPLE 20: APPLYING A MINUS PERCENTAGE(-%) DISCOUNT TO AN ITEM.....
64-65	EXAMPLE 21: APPLYING A MINUS PERCENTAGE(-%) DISCOUNT TO A TOTAL.....
65	EXAMPLE 22: APPLYING A PLUS PERCENTAGE(+%) RATE TO AN ITEM.....
65	EXAMPLE 23: APPLYING A PLUS PERCENTAGE(+%) RATE TO A TOTAL.....
66	EXAMPLE 24: RINGING IN A PRODUCT WITH A BARCODE.....
66	EXAMPLE 25: RINGING IN A DEPARTMENT USING THE DEPARTMENT SHIFT KEY.....
66	EXAMPLE 26: RINGING IN A DEPARTMENT # OVER 40.....

EXAMPLE 27: TEMPORARILY ADJUSTING A PLU PRICE.....66

EXAMPLE 28: CHECKING A PLU PRICE.....66

CHAPTER 6: OTHER CASH REGISTER FUNCTIONS.....67-71

6.1 Turning the receipt printer ON / OFF.....67

6.2 Printing a Duplicate Receipt.....67

6.3 Printing a Commercial Receipt.....67

6.4 Checking the Time / Date in REG mode.....68

6.5 Using Calculator Mode.....68

6.6 Using the Foreign Currency(FC) Function.....69-70

6.7 Saving / Loading Programming Data Using a USB Drive.....70

6.8 Saving / Loading Data from a PC.....70-71

CHAPTER 7: TROUBLESHOOTING.....72-73

7.1 General Error Messages.....72

7.2 Paper End or Printer Errors.....72

7.3 No Receipt Is Printing.....72

7.4 Nothing is printing on the receipt.....72

7.5 The Cash Register Display goes dark.....72

7.6 If the Cash Register does not work.....72

7.7 If the Cash Register does not work at all.....72

7.8 Opening the cash drawer manually or when there is no power.....72

7.9 Half System Clear.....73

7.10 Full System Clear.....73

7.11 If nothing Helps.....73

CHAPTER 8: PRODUCT INFORMATION.....74-77

CHAPTER 1: WELCOME

1.1 UNPACKING YOUR CASH REGISTER and SET-UP

PREPARATION

When your cash register is new in its factory packaging, you will find the various items for the register packaged separately. Look for and unwrap the following: 2 starter paper rolls, a black journal winder spindle, a USB cable, 3XAA memory backup batteries, and duplicate key sets for the Control Lock and Cash Drawer Lock.

STANDARD ACCESSORIES

The following are included in the box with your cash register:

- Instruction manual
- (1) black plastic journal winder spindle
- (2) starter rolls of standard thermal paper tape (58mm), Royal Reorder Number (013127)
- (3) memory back-up batteries (AA) (must be installed in the cash register)
- 5 ft. USB Cable for PC Connection
- Keys: (2) Cash Drawer Keys (515), (2) Manager's Program Keys (MA, 33 I) (2) Operator Register Keys (OP, 33 A)

IT IS IMPORTANT THAT YOU READ THE INITIAL SET-UP AND MAINTENANCE INSTRUCTIONS BEFORE ATTEMPTING TO OPERATE THE CASH REGISTER.

***** VERY IMPORTANT *****
You MUST INITIALIZE the cash register after unpacking it and while plugging it in for the first time. This is before any programming or starting to use it. See Steps #3-6 below.

INITIAL SET UP

1. Locate on level surface - Before operating the cash register, be sure it is placed on a level surface to permits smooth operation of the register cash drawer.
2. This cash register operates on any standard three-hole electrical outlet (115-120 volt, 60 hertz). It is recommended that the cash register be connected to an electrical circuit where no other electrical device or appliance is connected which may overload the circuit or cause electrical interference with the cash register. It is best that a single circuit be provided for register operations.
3. Insert Manager's Program Key (MA, 33 I) and turn to the "PRG" position.
4. Install paper - Refer to Page 11 for paper installation instructions.
5. Initialize the cash register by holding down the clear key while plugging in the cash register.
6. Install the batteries - Refer to Page 12.

MAINTENANCE FOR YOUR REGISTER

- Your register must remain uncovered when turned on; this will allow proper cooling of electronic components.
- Use a dust cover when the register is not in operation to protect mechanical components from dust.
- Take care to keep beverages and other liquids away from the machine to avoid spills which may damage electronic components (use optional protective keytop cover to prevent damage to machine).
- To clean the displays, use a soft dry cloth. Do not use harsh solutions containing alcohol.
- Your machine should be kept in areas free from dust, dampness or extreme temperatures (hot or cold).
- After storage in extreme temperatures (below 32 degrees Fahrenheit or above 104 degrees Fahrenheit), allow the temperature inside the machine enough time to reach room temperature before powering ON the unit.
- Never pull the paper roll through the printhead. To prevent damage, always use the electronic paper feed key.
- Should electronic service be needed, a Royal authorized service center is recommended.

1.2 GETTING TO KNOW YOUR CASH REGISTER

USING THIS MANUAL

Your cash register manual is organized for easy reference. Use the **TABLE OF CONTENTS** to locate a particular section you are interested in.

Throughout this manual, references to the keypad may include a picture of the function key. For example:

Press to redo an entry.

Also when certain programming or sales registration screens are discussed, a picture of the screen will accompany the description. For example:

Setting the Date : PROG → System Options → Date

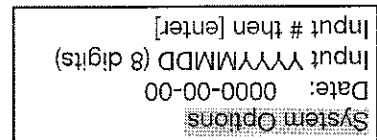

HOW TO GET STARTED

Before you begin to program or use your new Royal Cash Register, you should spend some time becoming familiar with the Control Lock System, the Keyboard Functions and the Displays. It may also be helpful to review setting up and basic maintenance information. To insure an easy setup, follow the Quick Start guide on page 15. Finish by practicing the transaction examples provided.

MAIN PARTS AND FUNCTIONS

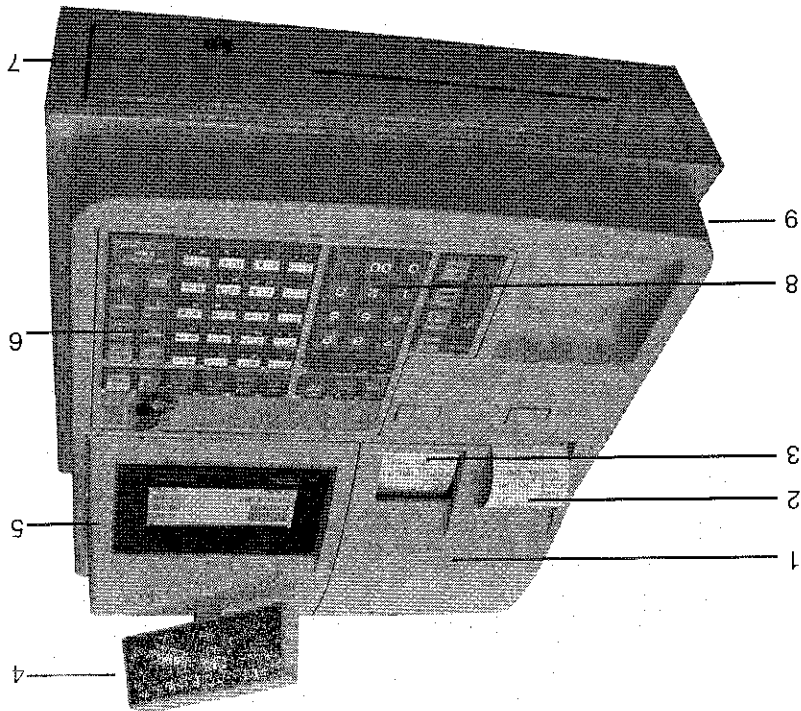

NAME OF PART	FUNCTION
1. Printer cover	Covers and protects the printers.
2. Receipt printer	This is where the receipts print to give to customers.
3. Journal printer	This is where the journal roll prints for business records.
4. Customer Display	This display shows department entries, sales totals and change due so the customer can follow the transactions.
5. Clerk Display	This display shows sales information, programming prompts and more to allow operation of the cash register.
6. Control lock	Using the supplied keys, the control lock allows switching to the different register modes.
7. Cash Drawer	The cash drawer stores cash, checks, credit card slips and more that will accrue during sales transactions. It can be manually locked as necessary.
8. Keyboard	The keyboard is used to make entries and operate the register.
9. USB Port	Use to connects to a barcode scanner, PC, or USB flash drive.

PART NAMES	FUNCTION
1. Journal location	The paper roll for record keeping (the journal) is located here.
2. Receipt location	The paper roll for receipts is located here.
3. Print-head unit	Prints the characters on the receipt and journal.
4. Take-up reel	Used to take up the paper roll used for record keeping (the journal).
5. Paper Exit	The paper exits here.
6. Platen Release Button (Receipt)	Used to release the platen for receipt.
7. Platen Release Button (Journal)	Used to release the platen for journal.

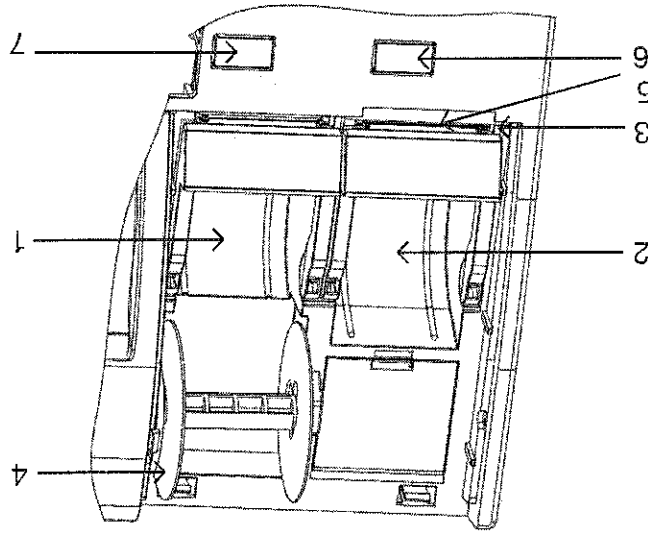

PRINTER COMPARTMENT
 Once the printer cover is removed, the printer compartment can be accessed. This compartment houses both printers, as well as the battery compartment. A breakdown of the different parts is shown below :

DESCRIPTION	MODE NAME	FUNCTION
PRG	Program mode	Used to adjust the settings and program the cash register.
OFF	Lock mode	Used to temporarily lock the cash register.
REG	Sales Registration	Used to process sales transactions.
X	Read Reports	Used to read/print reports without clearing the memory.
Z	Read/Reset Reports	Used to print/reset reports and clear the memory.

CONTROL LOCK
 The control lock is used to change the cash register modes. Your register is equipped with five modes which are used to perform the many different functions available. The cash register is always in one of these five modes for any operation. To change modes, use the manager's key (marked with "MA") and the operator's key (marked with "OP") which came with this cash register. For security purposes, only the manager key will allow access to the Programming, X, and Z modes. The operator key allows access to only the OFF and Register modes. A breakdown of each mode and its function is shown below :

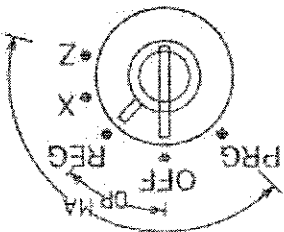

ABOUT THE DISPLAYS

The alpha 9500ML Cash register is equipped with a large 4-line LCD clerk display and a 1-line customer display. Each display will be further explained below :

Clerk Display

Your alpha 9500ML has a 4-line LCD display which is used to program and operate the register. On this display you will see the sales details, the programming options and more. Below are pictures of the clerk display screen(in PROG and REG mode) :

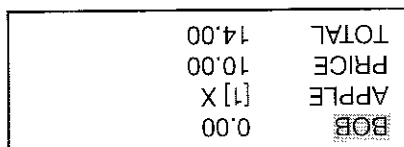
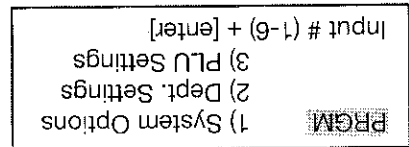

While operating the register, the display will show text that will help you accomplish many of the different tasks necessary to use the cash register. Use the keyboard to navigate through the display and enter any options. If you have trouble with a particular function, see its listing in this manual for guidance.

When ringing up sales, you see the department number or PLU number on the clerk screen. If a description or name is programmed, this description appears.

Customer Display

The alpha9500ML has a 1-line numeric customer display which can be rotated to many different angles. This display allows the customers to follow along during a transaction. A total of 8 characters (7 letters) can be displayed on the customer display at any time.

INSTALLING THE PAPER ROLLS

Your cash register has two thermal printers that print receipts for the customer and a journal tape. Use 2 1/4 inch (57/58mm) wide standard thermal register paper when replacement paper is necessary.

NOTE : Do not manually pull the receipt paper. Always use the feed keys to advance the paper when changing.

1. If prompted by the register or during initial setup open the printer compartment by lifting up on the tabs located towards the back of the register. This will expose the printers.

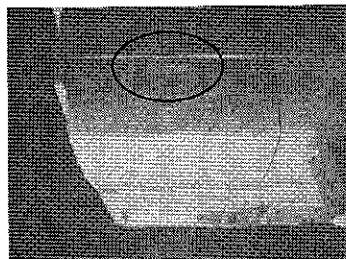
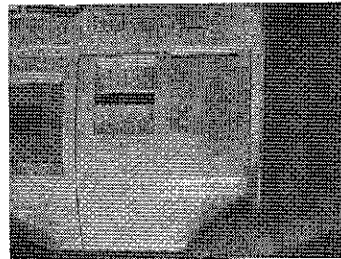

2. Depending on the printer side which is out of paper, use the release buttons to open the paper wells and release the print rollers.

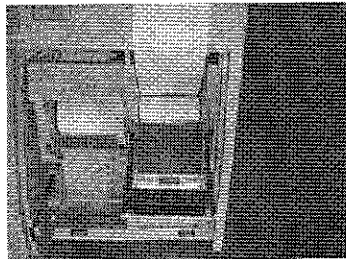
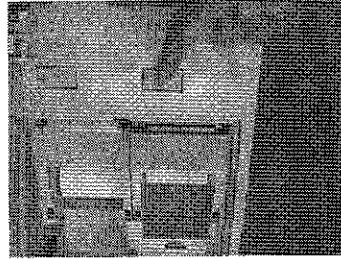

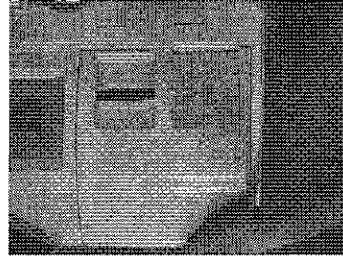
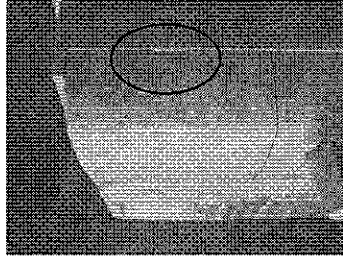

1. Open the printer compartment by lifting up on the tabs located towards the back of the register. This will expose the battery compartment.

NOTE: Make sure to install the backup batteries **AFTER** supplying power to your cash register. If the batteries are installed before power is supplied, your cash register can be damaged.

The alpha 9500ML cash register uses 3 x AA (1.5 volt) batteries for memory backup protection. In the event of a power loss, these batteries will insure that the programming and sales information of your cash register is not lost. Memory backup batteries should be installed at all times during usage of the cash register. Starter batteries should have been included with your shipment.

INSTALLING THE MEMORY BACKUP BATTERIES

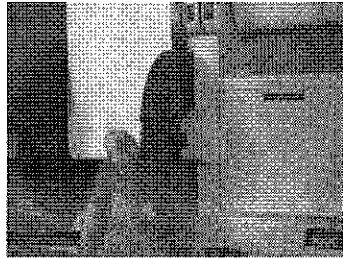

5. Once the paper is attached, place the winding wheel into the holder in the back of the printer compartment. The portion of the winding wheel with two disks should be situated on the right side. This will allow for contact with the winding motor and spinning of the wheel during operation.

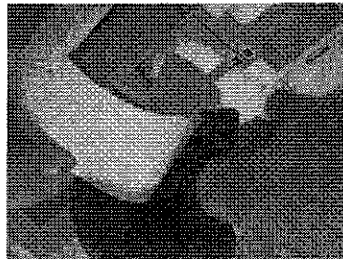
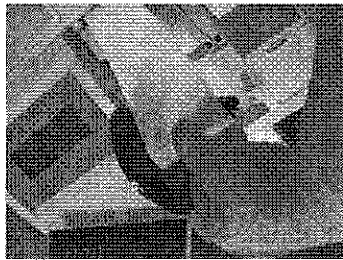

5. To attach the journal roll to the black winding wheel, remove the wheel from the printer compartment. Make a small fold on the end of the journal roll and feed it under and around the tabs located on the winding wheel. Spin the winding wheel manually to take up an excess paper.
4. Once finished, close the printer arms and use the feed keys to advance the paper.
3. Drop the paper into the paper well so it feeds from the bottom of the roll towards the front of the cash register (if the paper is placed incorrectly, the printers will NOT print). Pull the paper up and past the printer heads towards the front of the cash register.

2. With the printer cover removed, find the battery compartment. Install the batteries in the proper orientation (+ and -) as directed by the instruction in the compartment.

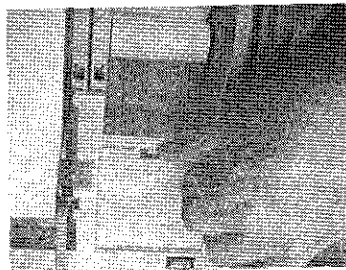
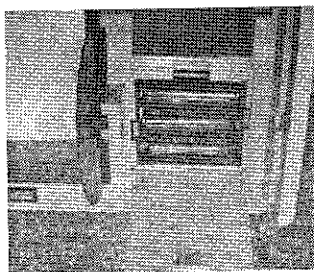

3. When finished, close the battery compartment cover, and re-install the printer cover.

USING THE KEYBOARD

The keyboard on your 9500ML is used to enter sales transactions, program the register and many other functions. Below is a picture of what the keyboard looks like :

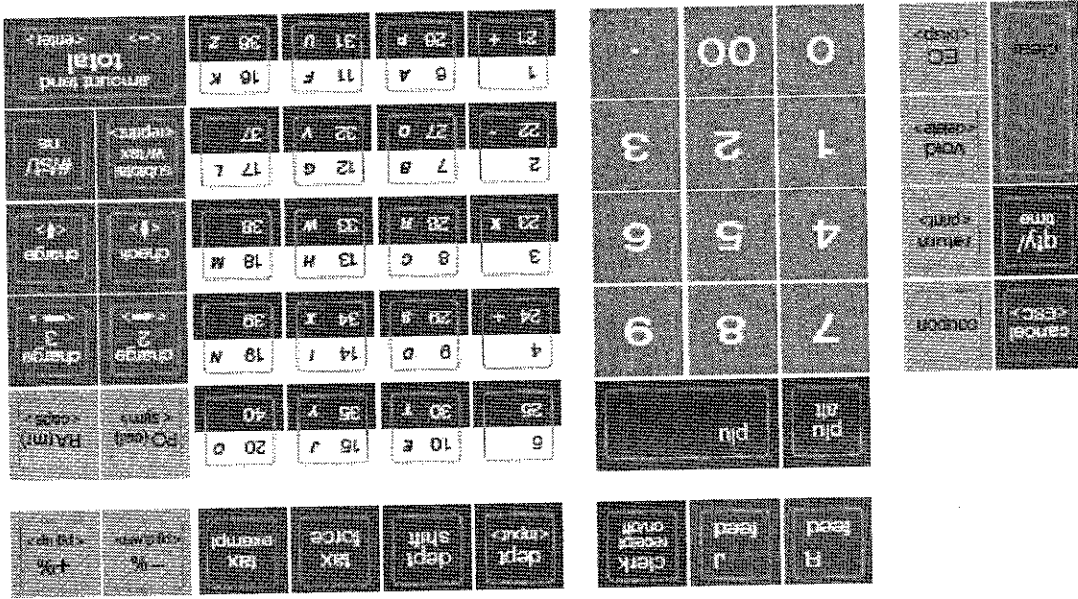

Many of the keyboard keys have dual functions. These functions are different depending on the mode currently active (programming, sales registration, etc.). The following table explains many of the keyboard functions :

Use these keys....	To do this...
cancel <ESC>	--to cancel the current transaction --to go back to a previous menu or setting
qty/time	--enter multiple quantities of a PLU or Department during a sale --show the time/date display on the clerk and customer display --clear an entry or error
clear	

--enter single entry coupon discounts	
--process a returned item	
--to void an item or transaction	
--correct the last entry during a sales transaction	
--feed the receipt or journal paper	
--log in a clerk for a sales transaction	
--temporarily adjust the price of a preset PLU or access a specific department	
--register a plu entry by using the PLU number or a barcode	
--enter a numerical value for a sale, programming option, etc.	Numeric keys 0 - 9
--enter a "00" or shift between double width characters	
--enter a decimal point	
--manually register a specific department	
--shift between departments or letters on the department keys	
--manually override a department tax rate or add --exempt tax for an individual item entry	
Department Keys(normal)	Department Keys(Alpha)
--enter a department entry during sales registration	--program a department, PLU or other text
--process a calculation when using calculator mode	Calculator Keys (X,+,,-,÷,=)
--navigate the programming options	
--move forward / back pages in the programming menus	
--enter manual or preset add-on and discount percentages	
--register a Paid-Out(PO) value during a sales transaction	
--(cal) enter/exit calculator mode in register mode	-->sym> toggle between letters and symbols while programming text
--register a Received-On-Account(RA) value	
--(m) recall a calculated value from calculator mode	-->caps> toggle caps lock ON/OFF while programming text
--finalize a transaction as a check sale	

QUICK START-UP GUIDE

The Quick Start program is designed to help you quickly "get started" with the basics you need to run your cash register. It covers programming the Date, Time, Tax Rate and Department Status for taxing or non-taxing. Follow the Quick Start straight through, however, skip any steps which are not required by your business needs. As you go through the Quick Start, if an error tone sounds, PRESS the [CLEAR] key and continue by repeating the step you are attempting to program.

NOTE: It is not necessary to repeat the entire Quick Start program if you wish to update or change a step at any time. Therefore, maintain your owner's manual in a safe place for all future programming.

IMPORTANT: Before beginning the Quick Start, read Unpacking Your Cash Register and Set Up (Page 7), Getting To Know Your Cash Register (Page 8), Control Lock (Page 10), Installing the Paper Roll (Page 11), Installing the Memory Back-up batteries (Page 12), and Using the Keyboard (Pages 13-15).

Before proceeding with Quick Start, the cash register must be initialized. Please see "Initial Set Up" on page 7.

1. Insert the Manager Program Key (MA) in the Control Lock and turn to the "PRG" program position.

2. Press **1** and **<enter>** to enter the **SYSTEM OPTIONS** menu.

3. The first option is **Programming the Date**. Enter the date as an 8-digit Number (YYYYMMDD). Confirm by pressing **Enter**.

4. After confirming the date you will automatically be taken to the **Programming the Time** screen. Enter the time in 24 hour format and confirm with **Enter**.

5. Continue to move through the available setting options if necessary, or press **ESC** to go back to the main programming menu.

6. From the main programming menu, press **4** then **<enter>** to enter **Tax Rate Programming**.

7. To set a **Tax 1** as single fixed tax rate (US standard), press **1** then **<enter>**.
 8. At the next screen select **Add-on Tax(US)** by pressing **0** then **<enter>**. You will now be asked for to input a percentage rate to apply to **Tax 1**. Enter this as a 6 digit number (XX.XXXX%) and press **<enter>**

System Options
 Date 0000-00-00
 Input YYYYMMDD (8 digits)
 Input # then [enter]

System Options
 Time 00:00
 24 hour system (4 digits)
 Input # then [enter]

--finalize a transaction as a charge(credit card) sale there are 3 charge keys preprogrammed on the 9500ML	charge	--display the subtotal with tax of the current transaction --reprint the last transactions receipt	subtotal (tax) (reprint)
--display and print the subtotal(without tax) of the current transaction --open the cash drawer and print a No-Sale transaction such as an invoice number or production serial number	#/ST us	--process a sale as a cash transaction --finalize a computation in calculator mode --enter a PLU, Department, or setting value while programming	total <=> <enter>

BEFORE GOING TO REGISTER MODE

Your Royal cash register offers many additional features not covered in the Quick Start programming. Please note that all programming options are covered in the Advanced Programming section of this manual, even those singled out for use in the Quick Start. Please review a few of the additional programming options available on this register described below which you may choose to review or add to your basic Quick Start set up. For quick reference, the page numbers are noted by each feature presented:

TRAINING MODE (PAGE 59): Designed to help you get acquainted with the register mode and allows a place for practicing transaction examples without effecting machine totals. Since the Training Mode does not record any transactions performed while in the register mode, it is ideal for beginners.

TRANSACTION EXAMPLES (Pages 60-66): Simple transaction examples are provided for use in the register mode. This section will cover a cash sale, check sale, charge sale, tendering change, multiple items, PLU sale, split tendering, voiding, as well as other frequently used functions. Be sure to have the key in the "REG" (register) mode when following the transaction examples. Suggestion: Practice the transaction examples after activating the Training Mode described above.

CLERK NUMBERS AND NAMES (Page 19-20): Clerk numbers can be used to monitor sales of 40 individual employees with clerk names.

MANAGER PASSCODES (Page 21-22): A passcode can be assigned for the "PRG", "X" and "Z" modes. **FLAG OPTIONS (Pages 38-42):** A total of 90 system programming options are offered on this cash register. They are preset by the factory to accommodate many of the most commonly used selections. These options can be changed to meet your individual needs.

9. Now that you have your time, date, and tax rate set you can apply the tax rate to a specific department.

Press **ESC** to go back to the programming main menu and press **2** then **<enter>** to enter the Department Programming menu.

10. By default, Dept 1 will be accessed. If you need to jump to a specific department now, you can do so. If not,

press **<+>** twice to reach the department flag settings. Press **<->** seven times to reach **Tax 1** flag settings. Press **(0)** to set Dept 1 as taxable with **Tax 1**.

11. Press **ESC** to go back to the main programming menu.

CHAPTER 2 : ADVANCED PROGRAMMING

2.1 MAIN PROGRAMMING MENUS

With the large clerk display size(4-lines), the alpha 9500ML cash register has built-in software prompts and text which helps you navigate through programming and operating the register. All of the available programming options (tax, PLUs, system options, and so on) are accessed through the main programming menu.









To access the main programming menu, insert the manager(MA) key into the control lock and turn it to the PRG position.

There are 16 available options in the **main programming menu**. Each will be explained within this user's manual. Below are each of the available options with a brief description of each :

1. **System Options** – Use this menu to set the main system parameters such as time, date, and receipt #.
2. **Dept. Settings** – Use this menu to setup department names, prices, and group #'s.
3. **PLU Settings** – this menu allows you to set PLU prices, names, and linking departments.
4. **Tax Rate Settings** – enter this menu to program your tax rates
5. **Tax Table Setup** – If you are using tax tables, you must set them here.
6. **Discount Settings** – Use this menu to set your Add-on %, Discount %, and Coupon keys.
7. **Config. Options** – The main system flags are located here.
8. **Keyboard Layout** – Within this menu, you can change the layout of your cash register's keyboard.
9. **Transaction Words** – From here you can rename the printed words on your receipts
10. **Receipt Header** – Set the header message here.
11. **Receipt Footer** – Set the footer message here.
12. **FC Settings** – the foreign currency settings and names can be accessed here.
13. **Clerk Settings** – Program clerk names and passcodes here.
14. **Manager Passcodes** – Set the programming, X, and Z passcodes here.
15. **Journal Message** – set the journal roll message here.
16. **Software Update** – If software upgrades are available, use this function to download them.

NAVIGATING THE PROGRAMMING MENUS

Navigating the clerk screen is very simple. See the table below for assistance using individual keys.

Use these keys....		To do this...
	 	--move FORWARD and BACK through the menus and system options
		--confirm an entry and move to the next option
		--to delete the highlighted character
		--backspace and delete one character while programming
		--move back one menu level
		--clear the typed entry and start over

2.2 SETTING ALPHANUMERIC DESCRIPTIONS

You can program customer header and footer messages, clerk names, departments, item descriptions, and even transaction words. These text messages and descriptions appear on the receipt and on the customer display.

When you are programming the alpha descriptions for Departments, PLUs, Clerks, and Header/Footer messages, use the Alpha Keyboard.

NOTE: Only capital letters of the alphabet are on the Alpha Keyboard. To use lower case letters, press the <caps> key.

The department keys are clearly labeled with all of the letters needed to program these descriptions. When you are programming alpha descriptions, use the department keys to spell out any words you want. The letters located in the white section of the department key can be entered simply by pressing the specific department key. To access the letters in the green section, press <dept shift> first. Numbers can be entered at any time using the number keys.

You may need certain special symbols on the Alpha Keyboard. For example, if you need to use a / or comma you can.

To access symbols, press the <sym> key. You can then use the arrow keys to scroll through the available symbols.

Press <enter> to input this character. To go back to the letters, press <sym> again. The available characters are shown below :

CHARACTER TABLE																
0	1	2	3	4	5	6	7	8	9	A	B	C	D	E	F	
	SP	0	@	P	.	p	ç	È	à	§	A	Ç	T	X		
1		1	A	O	a	q	u	æ	i	E	I	C	U	P		
2	AD	.	Z	B	R	b	r	è	Æ	ò	▲	U	C	U	P	
3		#	3	C	S	c	s	à	ò	▫	ò	e	w			
4		\$	4	D	T	d	t	à	ò	n	A	A	B	7	n	
5		%	5	E	U	e	u	è	ò	N	È	ò	d	ç	±	
6		&	6	F	V	v	f	à	ò	•	ò	â	S	Y	IM	
7		.	7	G	W	w	g	w	ç	U	e	A	ò	S	D	M
8		(8	H	X	h	x	è	y	?	E	~	Z	n	.	
9)	9	I	Y	y	i	è	ò	°	U	U	Z	I	.	
A		*	J	Z	j	z	è	ò	°	°	ò	X	J			
B		+	K	I	k	i	è	ò	°	°	A	U	J	o	I	
C		<	L	\	l	è	ò	°	°	°	E	ò	A	V	II	
D		=	M	J	m	j	è	ò	°	°	I	E	1	q	III	
E		>	N	v	n	~	A	H	è	ò	°	U	U	n	g	IV
F		/	?	O	-	o	A	f	è	ò	°	U	U	n	g	IV

NOTE : If you enter the wrong character, press the <bksp> key to delete the character. Now you can continue.

USING DOUBLE WIDTH CHARACTERS

For extra emphasis, you can program double wide characters for a specific character or a line of characters. To toggle this on or off press the (00) key. The screen will update to confirm the current status. The maximum number of characters that can be programmed for each item description in both normal and double width are shown below:

- Department – 12 characters normal / 6 characters double
- PLU – 16 characters normal / 8 characters double
- Clerk Name – 12 characters normal / 6 characters double
- Header/Footer/Journal Message – 5 lines, 24-characters normal / 5 lines, 12-characters double
- Transaction wordings – 8 characters normal / 4 characters double

Normal Size

```

*****
YOUR RECEIPT
Thank You
Call Again
*****
APPLE 1      1.00
MILK 1      2.00
ITEM CT 2
TAX          0.06%
CASH 3.06
03-24-2002 PM 04:14
0006
    
```

Double Width

```

*****
YOUR RECEIPT
Thank You
Call Again
*****
APPLE 1      1.00
MILK 1      2.00
ITEM CT 2
TAX          0.06%
CASH 3.06
03-24-2002 PM 04:14
0006
    
```

2.3 OTHER PROGRAMMING OPTIONS

The options covered in the Advanced Programming section are designed to let you customize your cash register operations, sales entry printouts, and management reports to meet your individual business requirements. The Advanced Programming can be used to further add options not covered by the Quick Start Program. Skip any or all sections which are not required in setting up your cash register. Note: During programming, if an error tone sounds or an error message displays, **PRESS the [CLEAR] key**, then continue by repeating the step you are attempting to program.

Note: It is not necessary to reprogram all options when you wish to update or change a step at any time. Therefore, maintain your owner's manual in a safe place for all future programming.

The programming of the cash register consists of the following features:

- Clerks Numbers and Names
- Manager Passcodes (PRG and X/Z)
- Date
- Time
- Machine Number
- 4 Tax Rates
- Coupon Discount (-/CPN)
- Minus Percentage Discount (-%)
- Plus Percentage (+%)
- Price Look-Ups (PLUs)
- Transaction Number Preset
- X1 and X2 Counter Preset
- Z1 and Z2 Counter Preset
- Header and Footer Messages
- Journal Messages
- Config. Options (Flags)
- Foreign Currency (FC) Setup
- Adjusting the Keyboard Layout
- Programming the Transaction Words

2.4 PROGRAMMING AND USING CLERKS

You can program clerks using the Clerk Settings menu. A total of 40 Clerk Numbers are available for monitoring sales of individual employees. Each Clerk Number can be programmed with a 12 character name. The Clerk Numbers are designed to be used in the REGISTER mode only. To obtain sales totals of each clerk, a Clerk Report is available in both the "X" and "Z" modes.

Extra Security Option: If desired, a procedure is offered to require entry of a Clerk Number before every transaction, for details see Flag 0608, Page 40.

TO PROGRAM A CLERK NAME

You can spell names using the department keys. For more information, see SETTING ALPHANUMERIC DESCRIPTIONS on page 18.

NOTE: The Clerk Name will print on the receipt tape. If no name has been programmed, the clerk number will print on the receipt. To log out a clerk, press [plu alt] and then [clerk].

1. Turn the key to the "REG" (REGISTER) position.
2. TYPE the clerk passcode and PRESS [clerk].
3. If the passcode is accepted, the clerk name or number will display on the clerk screen.

If the clerk security system is active, the clerk cannot enter a transaction in sales registration (REG) mode unless a clerk is logged.

USING CLERKS

NOTE: If a mistake occurs during the programming of a clerk passcode, PRESS the [CLEAR] key and begin again with Step 6.

1. Turn the key to the "PRG" (PROGRAM) position.
2. If a PRG manager passcode has been programmed, TYPE the (PASSCODE #), then PRESS [enter], or if you did not program a PRG manager passcode, go to Step 3.
3. TYPE 1, 3 and press [enter] to access the clerk settings menu.
4. Clerk 1 will be available by default. If you would like to access a particular clerk, TYPE the clerk number (1-40) and press [input].
5. PRESS [↑ ↓] to move to the clerk passcode menu.
6. Input passcode, up to 4 numbers, using the numerical keys.
7. PRESS the [enter] key to finalize.
8. After programming the passcode, you will automatically be taken to the next available clerk name menu. Program another clerk or PRESS [esc] to exit to the main menu.

CLERK 10	PASSCODE
	10
	4 digit maximum
	Input # then [enter]

PROGRAMMING → 13) Clerk Settings → Clerk Passcode

TO PROGRAM A CLERK PASSCODE

You can program a clerk passcode of up to four digits (XXXX).

1. Turn the key to the "PRG" (PROGRAM) position.
2. If a PRG manager passcode has been programmed, TYPE the (PASSCODE #), then PRESS [enter], or if you did not program a PRG manager passcode, go to Step 3.
3. TYPE 1, 3 and press [enter] to access the clerk settings menu.
4. Clerk 1 will be available by default. If you would like to access a particular clerk, PRESS [input]. TYPE the clerk number (1-40) and then [input].
5. Input name, up to 12 characters, using the alpha keyboard (Department keys). Remember, the Department Shift key accesses the letters in the lower green section of the Department keys. As you enter the name, the characters appear on the display. If you need a space to separate the first name and last name, use the [.] key or [→] to program the space.
6. PRESS the [enter] key to finalize.
7. After programming the name, you will automatically be taken to the clerk passcode menu for the previously selected clerk. Program it now or PRESS [esc] to exit to the main menu.

CLERK 10	(ABCD)NAME
	TOM
	Enter Alpha characters:
	[A to O]

PROGRAMMING → 13) Clerk Settings → Clerk Name

2.5 SETTING MANAGER PASSCODES

The manager passcodes can be programmed using the **Manager Passcode** menu. Three four digit **Manager Passcodes** are available as an added measure; one passcode accesses only the "PRG" (PROGRAM) position, one passcode accesses the "Z" mode, and another accesses only the "X" mode. The passcodes reset every time they are used, therefore once a passcode has been programmed, it must be entered every time you access the corresponding mode. You can also set a training passcode to enter / exit training mode.

IMPORTANT : The manager passcodes cannot be set to 0000.

CAUTION: Write your passcodes down in a safe place. If you forget the passcodes, and are unable to access the manager passcode menu, you must perform a FULL SYSTEM CLEAR procedure.

TO PROGRAM THE X PASSCODE

The X passcode is used to access "X" mode.

PROGRAMMING → 14) Manager Passcodes → X Passcode

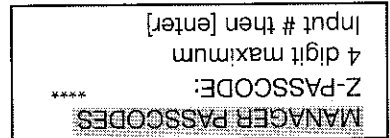

1. Turn the key to the "PRG" (PROGRAM) position.
2. If a PRG manager passcode has been programmed, TYPE the (PASSCODE #), then PRESS [enter] , or if you did not program a PRG manager passcode, go to Step 3.
3. TYPE 1, 4 and press [enter] to access the manager passcodes menu.
4. X-Passcode will be the first available option.
5. Input passcode, up to 4 numbers, using the numerical keys.
6. PRESS the [enter] key to finalize.
7. After programming the passcode, you will automatically be taken to the next passcode option. Program another passcode or PRESS [esc] to exit to the main menu.

TO PROGRAM THE Z PASSCODE

The Z passcode is used to access "Z" mode.

PROGRAMMING → 14) Manager Passcodes → Z Passcode

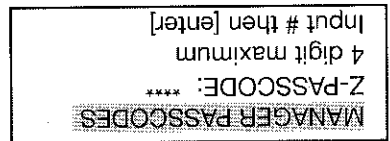

1. Turn the key to the "PRG" (PROGRAM) position.
2. If a PRG manager passcode has been programmed, TYPE the (PASSCODE #), then PRESS [enter] , or if you did not program a PRG manager passcode, go to Step 3.
3. TYPE 1, 4 and press [enter] to access the manager passcodes menu.
4. PRESS [↑] to move to the Z-passcode menu.
5. Input passcode, up to 4 numbers, using the numerical keys.
6. PRESS the [enter] key to finalize.
7. After programming the passcode, you will automatically be taken to the next passcode option. Program another passcode or PRESS [esc] to exit to the main menu.

- 1. Date
- 2. Time
- 3. Transaction number
- 4. Machine number
- 5. X1 Report number
- 6. X2 Report number
- 7. Z1 Report number

The system options menu includes many of the basic settings for your 9500ML cash register. These include the date, time, machine number and so on. All of the options are accessed in the programming position, through the **System Options** menu. Below is a list of the available system options (in accessible order). Once the system options menu is reached, you can use the arrow keys and page up / down keys to move to any particular option you desire.

2.6 PROGRAMMING THE SYSTEM OPTIONS

Using any programmed manager passcodes is self-explanatory. Enter the desired mode (X,Z,Prog) and you will be prompted to input the required passcode. The training passcode is used to start / end training mode. Training mode is accessed through the X position and will be explained later in this manual.

USING MANAGER PASSCODES

1. Turn the key to the "PRG" (PROGRAM) position.
2. If a PRG manager passcode has been programmed, TYPE the (PASSCODE #), then PRESS [enter] , or if you did not program a PROG manager passcode, go to Step 3.
3. TYPE 1, 4 and press [enter] to access the manager passcodes menu.
4. PRESS [↑] three times to move to the PROG passcode menu.
5. Input passcode, up to 4 numbers, using the numerical keys.
6. PRESS the [enter] key to finalize.
7. After programming the passcode, you will automatically be taken to the next passcode option. Program another passcode or PRESS [esc] to exit to the main menu.

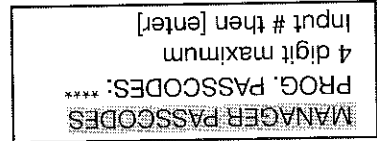

PROGRAMMING → 14) Manager Passcodes → Prog. Passcode

TO PROGRAM THE PROGRAMMING(PROG) PASSCODE

1. Turn the key to the "PRG" (PROGRAM) position.
2. If a PRG manager passcode has been programmed, TYPE the (PASSCODE #), then PRESS [enter] , or if you did not program a PROG manager passcode, go to Step 3.
3. TYPE 1, 4 and press [enter] to access the manager passcodes menu.
4. PRESS [↑] twice to move to the training-passcode menu.
5. Input passcode, up to 4 numbers, using the numerical keys.
6. PRESS the [enter] key to finalize.
7. After programming the passcode, you will automatically be taken to the next passcode option. Program another passcode or PRESS [esc] to exit to the main menu.

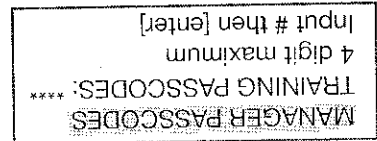

PROGRAMMING → 14) Manager Passcodes → Training Pass.

TO PROGRAM THE TRAINING PASSCODE

The training passcode is used to start / end training mode(enter in the X position).

- 8. Z2 Report number
- 9. Cash Alarm

TO PROGRAM THE DATE

The DATE is designed to roll over automatically every day and prints in the month-day-year format. You can select whether the date prints, or its format in the Config. Options menu

PROGRAMMING → 1) System Options → Date

System Options
Date: 0000-00-00
Input YYMMDD (8 digits)
Input # then [enter]

1. Turn the key to the "PRG" (PROGRAM) position.
2. If a PRG manager passcode has been programmed, TYPE the (PASSCODE #), then PRESS [enter] , or if you did not program a PRG manager passcode, go to Step 3.
3. TYPE 1 and press [enter] to access the system options menu.
4. Programming the date is the first available option.
5. Input the date in YYYYMMDD format using the numerical keys.
6. PRESS the [enter] key to finalize.
7. After programming the date, you will automatically be taken to the next system option. Program another option or PRESS [esc] to exit to the main menu.

TO PROGRAM THE TIME

The time can only print in 24 hour format.

PROGRAMMING → 1) System Options → Time

System Options
Time: 00:00
24 hour system (4 digits)
Input # then [enter]

1. Turn the key to the "PRG" (PROGRAM) position.
2. If a PRG manager passcode has been programmed, TYPE the (PASSCODE #), then PRESS [enter] , or if you did not program a PRG manager passcode, go to Step 3.
3. TYPE 1 and press [enter] to access the system options menu.
4. PRESS [↑ ↓] to move to the time setting option.
5. Input the time in 24-hour format using the numerical keys.
6. PRESS the [enter] key to finalize.
7. After programming the time, you will automatically be taken to the next system option. Program another option or PRESS [esc] to exit to the main menu.

TO PROGRAM THE TRANSACTION NUMBER

The transaction number is a specific number that will print on all receipts and reports. This number will count from its starting position until it is reset or reprogrammed.

PROGRAMMING → 1) System Options → Transaction #

System Options
Transaction #: 1
8 digit maximum
Input # then [enter]

1. Turn the key to the "PRG" (PROGRAM) position.
2. If a PRG manager passcode has been programmed, TYPE the (PASSCODE #), then PRESS [enter] , or if you did not program a PRG manager passcode, go to Step 3.

1. Turn the key to the "PRG" (PROGRAM) position.
2. If a PRG manager passcode has been programmed, TYPE the (PASSCODE #), then PRESS [enter] , or if you did not program a PRG manager passcode, go to Step 3.
3. TYPE 1 and press [enter] to access the system options menu.
4. PRESS [↑] four times to move to the X1 report number setting option.
5. Input the X1 report number (up to 4 digits) using the numerical keys.
6. PRESS the [enter] key to finalize.
7. After programming the X1 report number, you will automatically be taken to the next system option. Program another option or PRESS [esc] to exit to the main menu.

System Options
X1 Report #: 0
4 digit maximum
Input # then [enter]

PROGRAMMING → 1) System Options → X1 Report

The X1 report number is a specific number that can print on all X1 (daily) reports. This number will count from its starting position and increase with each report printed.

TO PROGRAM THE X1 Report Number

1. Turn the key to the "PRG" (PROGRAM) position.
2. If a PRG manager passcode has been programmed, TYPE the (PASSCODE #), then PRESS [enter] , or if you did not program a PRG manager passcode, go to Step 3.
3. TYPE 1 and press [enter] to access the system options menu.
4. PRESS [↑] three times to move to the machine number setting option.
5. Input the machine number (up to 4 digits) using the numerical keys.
6. PRESS the [enter] key to finalize.
7. After programming the machine number, you will automatically be taken to the next system option. Program another option or PRESS [esc] to exit to the main menu.

System Options
MACHINE #: 1
4 digit maximum
Input # then [enter]

PROGRAMMING → 1) System Options → Machine

The machine number is a unique number you give to your cash register which can print on receipts. To turn on/off the printing of this see the Config. Options menu.

TO PROGRAM THE MACHINE NUMBER

3. TYPE 1 and press [enter] to access the system options menu.
4. PRESS [↑] twice to move to the transaction number setting option.
5. Input the transaction number (up to 8 digits) using the numerical keys.
6. PRESS the [enter] key to finalize.
7. After programming the transaction number, you will automatically be taken to the next system option. Program another option or PRESS [esc] to exit to the main menu.

TO PROGRAM THE X2 Report Number
 The X2 report number is a specific number that can print on all X2(periodic) reports. This number will count from its starting position and increase with each report printed.

PROGRAMMING → 1) System Options → X2 Report #

System Options
X2 Report #: 0
4 digit maximum
Input # then [enter]

1. Turn the key to the "PRG" (PROGRAM) position.
2. If a PRG manager passcode has been programmed, TYPE the (PASSCODE #), then PRESS [enter], or if you did not program a PRG manager passcode, go to Step 3.
3. TYPE 1 and press [enter] to access the system options menu.
4. PRESS [↑] five times to move to the X2 report number setting option.
5. Input the X2 report number (up to 4 digits) using the numerical keys.
6. PRESS the [enter] key to finalize.
7. After programming the X2 report number, you will automatically be taken to the next system option. Program another option or PRESS [esc] to exit to the main menu.

TO PROGRAM THE Z1 Report Number
 The Z1 report number is a specific number that can print on all Z1(daily) reports. This number will count from its starting position and increase with each report printed.

PROGRAMMING → 1) System Options → Z1 Report #

System Options
Z1 Report #: 0
4 digit maximum
Input # then [enter]

1. Turn the key to the "PRG" (PROGRAM) position.
2. If a PRG manager passcode has been programmed, TYPE the (PASSCODE #), then PRESS [enter], or if you did not program a PRG manager passcode, go to Step 3.
3. TYPE 1 and press [enter] to access the system options menu.
4. PRESS [↑] six times to move to the Z1 report number setting option.
5. Input the Z1 report number (up to 4 digits) using the numerical keys.
6. PRESS the [enter] key to finalize.
7. After programming the Z1 report number, you will automatically be taken to the next system option. Program another option or PRESS [esc] to exit to the main menu.

TO PROGRAM THE Z2 Report Number
 The Z2 report number is a specific number that can print on all Z2 (periodic) reports. This number will count from its starting position and increase with each report printed.

PROGRAMMING → 1) System Options → Z2 Report #

System Options
Z2 Report #: 0
4 digit maximum
Input # then [enter]

1. Turn the key to the "PRG" (PROGRAM) position.
2. If a PRG manager passcode has been programmed, TYPE the (PASSCODE #), then PRESS [enter], or if you did not program a PRG manager passcode, go to Step 3.
3. TYPE 1 and press [enter] to access the system options menu.
4. PRESS [↑] seven times to move to the Z2 report number setting option.
5. Input the Z2 report number (up to 4 digits) using the numerical keys.

1. Turn the key to the "PRG" (PROGRAM) position.
2. If a PRG manager passcode has been programmed, TYPE the (PASSCODE #), then PRESS [enter] , or if you did not program a PRG manager passcode, go to Step 3.
3. TYPE 2 and press [enter] to access the department settings menu.
4. Department 1 will be shown by default. If you would like to access a particular department, PRESS [input], TYPE the department number (1-200) and then [input] .
5. Input name, up to 12 characters, using the alpha keyboard (Department keys). Remember, the Department Shift key accesses the letters in the lower green section of the Department keys. As you enter the name, the characters appear on the display. If you need a space, use the [.] key or [→] to program the space.

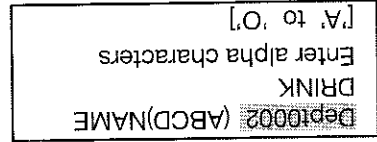

PROGRAMMING → 2) Dept. Settings → Dept. Name

TO PROGRAM A DEPARTMENT NAME

You can enter department names using the department keys. For more information, see SETTING ALPHANUMERIC DESCRIPTIONS on page 10.

manual.

Within the Dept. Settings menu, there are many different options available. These include department name, department price, department taxable status, and so on. Each of the available options will be explain in this section of the

programming menu.

Departments are a category of merchandise. For example, Department 1 can be Housewares, Department 2 can be Food, Department 3 can be Clothing, and so on. This helps you track what you are selling. Each department can be programmed as taxable or non-taxable(the default setting), so that if an item needs to be taxed, the proper tax amount is added automatically when you ring up an item in a taxable department. There are 200 departments available on your 9500ML cash register. To program a department or change a department setting, access Dept. Settings from the main

2.7 PROGRAMMING DEPARTMENTS

1. Turn the key to the "PRG" (PROGRAM) position.
2. If a PRG manager passcode has been programmed, TYPE the (PASSCODE #), then PRESS [enter] , or if you did not program a PRG manager passcode, go to Step 3.
3. TYPE 1 and press [enter] to access the system options menu.
4. PRESS [] eight times to move to the cash alarm setting option.
5. Input the cash alarm value (up to 10 digits) using the numerical keys.
6. PRESS the [enter] key to finalize.
7. After programming the cash alarm, you will automatically be taken to the next system option. Program another option or PRESS [esc] to exit to the main menu.

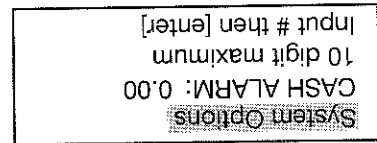

PROGRAMMING → 1) System Options → Cash Alarm

TO PROGRAM THE CASH ALARM

The cash alarm is a value that you can set which will alarm you when the cash amount in your cash drawer has reached a specific amount. This is useful to remind you to remove cash from the drawer when there may too much in the drawer.

6. Press the [enter] key to finalize.
7. After programming the Z2 report number, you will automatically be taken to the next system option. Program another option or PRESS [esc] to exit to the main menu.

6. **PRESS the [enter] key to finalize.**
7. After programming the department name, you will automatically be taken to the department price setting. Program that now or **PRESS [esc]** to exit to the main menu.

TO PROGRAM A DEPARTMENT PRICE

You can enter a preset department price (8 digit maximum) which can be accessed using the department keys while in sales registration mode.

PROGRAMMING → 2) Dept. Settings → Dept. Price

Dept0002	UNIT PRICE	0.00	8 digit maximum
	Price		

1. Turn the key to the "PRG" (PROGRAM) position.
2. If a PRG manager passcode has been programmed, **TYPE** the (PASSCODE #), then **PRESS [enter]**, or if you did not program a PRG manager passcode, go to Step 3.
3. **TYPE 2** and press **[enter]** to access the department settings menu.
4. Department 1 will be shown by default. If you would like to access a particular department, **PRESS [input]**, **TYPE** the department number (1-20) and then **[input]**.
5. **PRESS [↑]** to access the department price setting.
6. Input the department price (up to 8 digits) using the numerical keys.
7. **PRESS the [enter] key to finalize.**
8. After programming the department price, you will automatically be taken to the department flags menu. Program them now or **PRESS [esc]** to exit to the main menu.

TO PROGRAM DEPARTMENT FLAGS (TAX STATUS AND MORE)

Each department has a number of different setup options which can be programmed. These range from taxable status (taxes 1/2/3/4), department types and more. There are 8 different flags for each department. These flags are accessed through the **Dept. Settings** menu. When you access an individual flag, the 9500ML software prompts will help you understand each flag. Each will be explained here (in accessible order) :

8. **NOT USED FOR DEPARTMENTS**
7. **Gallonage Department ON/OFF (default is OFF)** – gallonage refers to department which allows for price entries which include 3 decimal digits. This is useful if you sell items which are portrayed as a unit of measurement (gallons, pounds, yards, etc.). For example, \$2.899 / gallon.
6. **Allow negative entries YES/NO (default is NO)** – this allows you to set the price or enter a price that is a negative number. This is useful when you need to assign preset discounts or coupons.
5. **Department Entry Type -- Single or Normal (default is single)** – Normal type allows you to ring up two or more items in a department, and single only allows you to ring up on item in a department.
4. **Tax 4 ON/OFF (default is OFF)** – applies tax 4 to a department
3. **Tax 3 ON/OFF (default is OFF)** – applies tax 3 to a department
2. **Tax 2 ON/OFF (default is OFF)** – applies tax 2 to a department
1. **Tax 1 ON/OFF (default is OFF)** – applies tax 1 to a department

PROGRAMMING DEPARTMENT FLAGS

PROGRAMMING → 2) Dept. Settings → Setup

Dept0002#5000000000 SETUP	Department entry type	0=Normal	1=Single entry
	Input # then [enter]		

1. Turn the key to the "PRG" (PROGRAM) position.
2. If a PRG manager passcode has been programmed, **TYPE** the (PASSCODE #), then **PRESS [enter]**, or if you did not program a PRG manager passcode, go to Step 3.

1. Turn the key to the "PRG" (PROGRAM) position.
2. If a PRG manager passcode has been programmed, TYPE the (PASSCODE #), then PRESS [enter], or if you did not program a PRG manager passcode, go to Step 3.
3. TYPE 2 and press [enter] to access the department settings menu.
4. Department 1 will be shown by default. If you would like to access a particular department, PRESS [input], TYPE the department number (1-200) and then [input].
5. PRESS [↑] four times to access the department group setting.
6. Input the department group (1-10) using the numerical keys.
7. PRESS the [enter] key to finalize.
8. After programming the department group, you will automatically be taken to department name programming for the next available department. You can continue on and program this now or PRESS [esc] to exit to the main menu.

Dept0002	DEPT HALO
HALO Price	0.00
7 digit maximum	
Input # then [enter]	

PROGRAMMING → 2) Dept. Settings → Dept. Group

You can link your department into groups and include all grouped departments in management reports. For example if Department 1 is set as "soda" and Department 2 is set as "juice", you can group them together to track all beverage sales.

TO PROGRAM A DEPARTMENT GROUP

1. Turn the key to the "PRG" (PROGRAM) position.
2. If a PRG manager passcode has been programmed, TYPE the (PASSCODE #), then PRESS [enter], or if you did not program a PRG manager passcode, go to Step 3.
3. TYPE 2 and press [enter] to access the department settings menu.
4. Department 1 will be shown by default. If you would like to access a particular department, PRESS [input], TYPE the department number (1-200) and then [input].
5. PRESS [↑] three times to access the department HALO setting.
6. Input the department HALO (up to 7 digits) using the numerical keys.
7. PRESS the [enter] key to finalize.
8. After programming the department HALO, you will automatically be taken to the department group menu. Program this now or PRESS [esc] to exit to the main menu.

Dept0002	DEPT HALO
HALO Price	0.00
7 digit maximum	
Input # then [enter]	

PROGRAMMING → 2) Dept. Settings → Dept. Halo

You can specify the largest amount that can be rung up in a department entry. This feature helps to prevent against large over-rings. If too many digits are entered, the error beep sounds and an error message appears on the display. At this point you have to clear the last entry and start over.

TO PROGRAM A DEPARTMENT HIGH AMOUNT LOCK-OUT (HALO)

3. TYPE 2 and press [enter] to access the department settings menu.
4. Department 1 will be shown by default. If you would like to access a particular department, PRESS [input], TYPE the department number (1-200) and then [input].
5. PRESS [↑] twice to access the department flag menu.
6. PRESS [←] or [→] to reach the particular flag (1-8) you wish to set.
7. Using the screen prompt as a guide, enter 0 or 1 as desired and press [enter].
8. After programming a flag, you will automatically be taken to the next department flag option. If you are currently programming the tax 1 status, pressing enter will take you to the department halo option. Otherwise, program another flag or PRESS [esc] to exit to the main menu.

2.8 PROGRAMMING PRICE LOOK-UPS(PLUs)

The Price Look-Up system allows for fast, accurate entry of an item and automatically records the number of items sold. If you want to use the optional barcode reader, you can scan UPC codes to ring up items. To scan barcodes, they must be numeric only, 13 digits or less, and must be one of the following barcode types and standards:

- UPC-A / UPC-E
- EAN-8 / EAN-13

NOTE: This cash register cannot generate barcodes for you. To generate and print barcodes, purchase barcode software and a printer.

Each PLU must be programmed with up to a 16 character description that appears on the display and prints on the tape. There are 5000 PLUs available on your 9500ML cash register. To program a PLU or change a PLU setting access **PLU Settings** from the main programming menu.

TO PROGRAM A PLU NUMBER OR BARCODE

You can program a PLU as a barcode number (up to 13 digits) or any sequence number you desire. For example, you can program a PLU as "Apple", and set it to ring in when you use the code 14. If you are going to use barcodes, or barcode numbers for your PLUs make sure you set the **System Options flag 0706** to "CODE".

PROGRAMMING → 3) PLU Settings → PLU # / Barcode

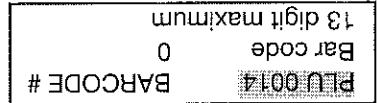

1. Turn the key to the "PRG" (PROGRAM) position.
2. If a PRG manager passcode has been programmed, TYPE the (PASSCODE #), then PRESS [enter], or if you did not program a PRG manager passcode, go to Step 3.
3. TYPE 3 and press [enter] to access the PLU settings menu.
4. PLU 1 will be shown by default. If you would like to access a particular PLU, PRESS [input], TYPE the PLU number and then [input]. If you are using the barcode reader, you can simply scan the barcode. If the barcode is programmed, the cash register will find it and display it otherwise it will move to the next available PLU.
5. Input the PLU barcode number or sequence number using the numeric keys (unless a barcode reader is used).
6. PRESS the [enter] key to finalize.
7. After programming the PLU number, you will automatically be taken to the PLU name menu. Program that now or PRESS [esc] to exit to the main menu.

TO PROGRAM A PLU NAME

You can enter PLU names using the department keys. For more information, see SETTING ALPHANUMERIC DESCRIPTIONS on page 10.

PROGRAMMING → 3) PLU Settings → PLU Name

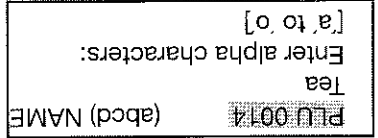

1. Turn the key to the "PRG" (PROGRAM) position.
2. If a PRG manager passcode has been programmed, TYPE the (PASSCODE #), then PRESS [enter], or if you did not program a PRG manager passcode, go to Step 3.
3. TYPE 3 and press [enter] to access the PLU settings menu.
4. PLU 1 will be shown by default. If you would like to access a particular PLU, PRESS [input], TYPE the PLU number and then [input]. If you are using the barcode reader, you can simply scan the barcode. If the barcode is programmed, the cash register will find it and display it otherwise it will move to the next available PLU.
5. PRESS [↑] to access the PLU name setting.
6. Input name, up to 16 characters, using the alpha keyboard (Department keys). Remember, the Department Shift key accesses the letters in the lower green section of the Department keys. As you enter the name, the character

BARCODE LEARNING FUNCTION

The alpha 9500ML cash register has an automatic barcode learning function available. If you are using a barcode scanner, you can use this function to program PLUs using the barcode scanner while in sales registration(REG) mode. This saves time and effort during a sales transaction if you accidentally forget to program a PLU. To use this function, you have to turn the Config. Options flag 1201 to 1(yes).

1. Turn the key to the "PRG" (PROGRAM) position.
2. If a PRG manager passcode has been programmed, TYPE the (PASSCODE #), then PRESS [enter], or if you did not program a PROG manager passcode, go to Step 3.
3. TYPE 3 and press [enter] to access the PLU settings menu.
4. PLU 1 will be shown by default. If you would like to access a particular PLU, PRESS [input], TYPE the PLU number and then [input]. If you are using the barcode reader, you can simply scan the barcode. If the barcode is programmed, the cash register will find it and display it otherwise it will move to the next available PLU.
5. PRESS [↑] [↓] three times to access the PLU department link setting.
6. Input the linking department (1-200) using the numeric keys.
7. PRESS the [enter] key to finalize.
8. After programming a PLU department link you will automatically be taken to the next available PLU. Repeat the sequence to program another PLU or PRESS [esc] to exit to the main menu.

PLU 0001	DEPT LINK
DEPT No.	0
Dept # (1-200)	
Input # then [enter]	

PROGRAMMING → (3) PLU Settings → PLU DEPT LINK

When programming a PLU, you must link it to a specific department. This allows the taxable and other settings to be applied to a PLU during registration.

TO PROGRAM A PLU LINKING DEPARTMENT

1. Turn the key to the "PRG" (PROGRAM) position.
2. If a PRG manager passcode has been programmed, TYPE the (PASSCODE #), then PRESS [enter], or if you did not program a PROG manager passcode, go to Step 3.
3. TYPE 3 and press [enter] to access the PLU settings menu.
4. PLU 1 will be shown by default. If you would like to access a particular PLU, PRESS [input], TYPE the PLU number and then [input]. If you are using the barcode reader, you can simply scan the barcode. If the barcode is programmed, the cash register will find it and display it otherwise it will move to the next available PLU.
5. PRESS [↑] [↓] twice to access the PLU price setting.
6. Input the PLU price (8 digit maximum) using the numeric keys.
7. PRESS the [enter] key to finalize.
8. After programming a PLU price, you will automatically be taken to the PLU department link menu. Program that now or PRESS [esc] to exit to the main menu.

PLU 0014	UNIT PRICE
Price	0.00
8 digit maximum	
Input # then [enter]	

PROGRAMMING → (3) PLU Settings → PLU Price

When programming a PLU, you must assign it a price so when it is entered, the price can be registered.

TO PROGRAM A PLU PRICE

7. PRESS the [enter] key to finalize.
 8. After programming a PLU name you will automatically be taken to the PLU price menu. Program that now or PRESS [esc] to exit to the main menu.
- ters appear on the display. If you need a space, use the [] key or [→] to program the space.

Once active, simply scan a barcode using the barcode scanner while in REG mode and the system will prompt you with [pr] to signify that a price is required. Enter the price using the numeric keys and then press the corresponding department.

After confirming the department, the PLU is now saved within the cash register's memory. You can go back and adjust these PLU settings through the programming menu.

PRICE CHECKER FUNCTION

In sales registration mode, you can check the price of a PLU by pressing the [00] key before scanning a barcode or entering a PLU number. If the PLU is not found, the error message "PLU code does not exist".

2.9 PROGRAMMING TAX RATES

Four different tax rates can be programmed on your cash register. Each tax rate can be linked directly to a Department key or by using the [tax force] key before ringing up an entry. You can change the way the tax rates print on the receipt, or if they print on the receipt by using the **Config. Options**.

Each Tax Rate can be programmed as follows:

- a. **As an ADD-ON RATE (used in the USA)** - which means the tax amount prints separately on the receipt. Add-on Tax is most common in the United States.
- b. **TAX TABLE** - Add-on Tax can be programmed as either a fixed-rate which charges tax based on a percentage, or using the tax table codes, which is a calculation based on an approved tax chart issued by your local or state government.
- c. **VAT (Value Added Tax)** - which means that the tax amount is included in the price of the item.
- d. **CANADIAN TAX SYSTEM** - allows the programming of GST/PST tax system required in Canada.

NOTE: To use a GST-PST tax(Canadian) you must set your tax rate(1,2,3,4) as an Add-On tax rate and then activate the Canadian Tax flag(1005).

PROGRAMMING A TAX TYPE

PROGRAMMING → 4) Tax Settings → Tax Type

TAX 02	RATE	0.0000%	Percentage t t (4 decimals)	6 digits t t (4 decimals)	Input # then [enter]
--------	------	---------	-----------------------------	---------------------------	----------------------

1. Turn the key to the "PRG" (PROGRAM) position.
2. If a PRG manager passcode has been programmed, TYPE the (PASSCODE #), then PRESS [enter] , or if you did not program a PRG manager passcode, go to Step 3.
3. TYPE 4 and press [enter] to access the Tax settings menu.
4. At the main screen, select the tax you would like to set (1-4) by TYPING the corresponding number using the numeric keys and pressing [enter] . After confirming, you will be automatically be taken to the tax type setting menu.
5. At the tax type menu, select the tax type you would like to set (ADD-ON, VAT, TAX TABLE) by TYPING the corresponding number and pressing [enter] .
6. If you select TAX TABLE, you will be brought back to the main Tax settings menu. If you chose anything else, you will be brought to the tax % menu. You can program this now or press [esc] to go back to the main programming menu.

PROGRAMMING A TAX RATE(%)

Once programmed and applied, the tax % will automatically calculate during a transaction when necessary.

Every tax table consists of tax brackets. Each consecutive tax bracket is assigned a tax which is exactly one cent higher than that assigned to the previous tax bracket. In the **Program Example** that follows a sale from 0¢ to 14¢ is not taxed. However, in the next tax bracket a sale from 15¢ to 37¢ is taxed 1¢. Likewise, in the next tax bracket a sale from 38¢ to 62¢ is taxed 2¢. The tax table progresses in a similar form.

IMPORTANT: This is a one time only procedure. Once the code for the tax table has been established and entered into the register, it never has to be repeated. Please take the time to follow the example given and familiarize yourself with the method of determining the code. Then using the **Worksheet** that follows, fill in the appropriate amounts from your approved tax table and derive the corresponding code by simply following the steps given.

CALCULATING BREAKPOINTS

A tax table is a table which lists the applicable taxes for particular amounts within a sale. These tables are determined by your city, state, or federal government. If your area uses a tax code table, you must calculate your tax codes before you can finalize a tax table. The following section will help you do so.

2.10 PROGRAMMING A TAX TABLE OR CANADIAN TAX RATE

1. Turn the key to the "PRG" (PROGRAM) position.
2. If a PRG manager passcode has been programmed, TYPE the (PASSCODE #), then PRESS [enter], or if you did not program a PRG manager passcode, go to Step 3.
3. TYPE 4 and press [enter] to access the Tax settings menu.
4. At the main screen, select the tax you would like to set (1-4) by TYPING the corresponding number using the numeric keys and pressing [enter]. After confirming, you will be automatically be taken to the tax type setting menu.
5. PRESS [↑] twice to access the tax limit setting.
6. Input the limit amount (8 digit maximum) using the numeric keys.
7. After programming the tax limit you will automatically be taken to the main tax settings menu. Program that now or PRESS [esc] to exit to the main menu.

TAX:02	TAX LIMIT
Price	0.00
8 digit maximum	
Input # then [enter]	

PROGRAMMING → 4) Tax Settings → Tax Limit

The Tax Limit amount (or maximum tax exempt amount) is the maximum amount at which no tax is charged. This amount is directed by your local government office, and if you are unsure as to this amount contact them and ask for your local tax chart. The default value is \$0.00 which means all amounts are taxed.

PROGRAMMING THE TAX LIMIT

1. Turn the key to the "PRG" (PROGRAM) position.
2. If a PRG manager passcode has been programmed, TYPE the (PASSCODE #), then PRESS [enter], or if you did not program a PRG manager passcode, go to Step 3.
3. TYPE 4 and press [enter] to access the Tax settings menu.
4. At the main screen, select the tax you would like to set (1-4) by TYPING the corresponding number using the numeric keys and pressing [enter]. After confirming, you will be automatically be taken to the tax type setting menu.
5. PRESS [↑] to access the tax rate setting.
6. Input the tax percentage (4 decimals) using the numeric keys. For example, to set 6% enter 6000.
7. PRESS the [enter] key to finalize.
8. After programming a tax % rate you will automatically be taken to the tax limit menu. Program that now or PRESS [esc] to exit to the main menu.

TAX:02	Type=0
Select Tax Type:	
0=ADD-ON 1=VAT 2=TAX TB	
Input # then [enter]	

PROGRAMMING → 4) Tax Settings → Tax Percentage

The difference between the starting amounts of each consecutive tax bracket is call a "breakpoint". Every tax table consists of a particular sequence of breakpoints. In the **Program Example** that follows, the difference between 0¢ and 15¢ is 15¢. Therefore 15 is the first breakpoint. Likewise, the difference between 15¢ and 38¢ is 23¢. Therefore 23 is the second breakpoint. The breakpoints progress in a particular sequence throughout the entire tax table. This particular sequence of breakpoints is used to determine the programming code.

The sequence of breakpoints is divided into "Regular" and "Irregular" patterns. All tax tables repeat a pattern of regular breakpoints after a lower irregular breakpoint pattern. To determine the breakpoint patterns, it is first necessary to calculate the breakpoints. This is easily done by using the **Worksheet** that follows. Simply fill in Chart A with the amounts from your approved tax table. Then calculate the breakpoints as was previously explained and fill them in on Chart B. Continue to calculate the breakpoints until you have found the "Regular" repeat breakpoint pattern.

Program Example

CHART A		TAX BRACKET		CHART B	
From	To	Tax	From	To	Tax
15	\$0.00	\$0.14	\$0.00	\$0.14	\$0.00
23	0.15	0.37	0.15	0.37	0.01
25	0.63	0.87	0.63	0.87	0.03
25	0.88	1.12	0.88	1.12	0.04
25	1.13	1.42	1.13	1.42	0.05
30	1.43	1.78	1.43	1.78	0.06
36	1.79	2.12	1.79	2.12	0.07
34	2.13	2.42	2.13	2.42	0.08
30	2.43	2.71	2.43	2.71	0.09
29	2.72	2.99	2.72	2.99	0.10
28	3.00	3.28	3.00	3.28	0.11
29	3.29	3.57	3.29	3.57	0.12
29	3.58	3.85	3.58	3.85	0.13
28	3.86	4.14	3.86	4.14	0.14
29	4.15	4.42	4.15	4.42	0.15
28	4.43	4.71	4.43	4.71	0.16
29	4.72	4.99	4.72	4.99	0.17
28	5.00	5.28	5.00	5.28	0.18
29	5.29	5.57	5.29	5.57	0.19
29	5.58	5.85	5.58	5.85	0.20
..

STEP E
Enter the individual Breakpoints of the "Irregular" Breakpoint sequence.
(15,23,25,25,25,30,36,34,30)

STEP C
Enter the summation of the "Regular" Breakpoint sequence.
(200)

STEP F
Enter the individual Breakpoints of the "Regular" Breakpoint sequence.
(29,28,29,29,28,29,28)

STEP B
Enter first amount of the last tax bracket in the "Irregular" breakpoint sequence.
(243)

STEP D
Enter the difference between the last tax amount applicable to the "Regular" breakpoint sequence and the last tax amount applicable to the "Irregular" breakpoint sequence.
(7)

The tax table will progress in a similar manner.

Note: If necessary, a total of 65 Breakpoints can be programmed.

Please refer to the **Program Example**. Note the following:
Breakpoints - 15, 23, 25, 25, 30, 36, 34, 30 - Represents the "Irregular" pattern.
Breakpoints - 29, 28, 29, 28, 29, 28, 29, 28 - Represents the "Regular" repeat pattern.

As a check to ensure that the "Regular" repeat pattern has correctly been located, add up all the breakpoints of the pattern. In most cases the resulting number will be a multiple of a dollar (i.e. \$1.00 or \$2.00) or must be a number that will divide evenly into a dollar (i.e. 10¢, 25¢, 50¢). In the **Program Example**, the breakpoints -29, 28, 29, 28, 29, 28, 29, 28 add up to 200.

Please refer to the Program Example for additional illustrations of the steps.

PROGRAMMING → 5) Tax Table Setup → Tax Table Settings

TAX TABLE SETTINGS			
1) TAX TBL 1	2) TAX TBL 2	3) TAX TBL 3	4) TAX TBL 4

1. Turn the key to the "PRG" (PROGRAM) position.
2. If a PRG manager passcode has been programmed, TYPE the (PASSCODE #), then PRESS [enter], or if you did not program a PROG manager passcode, go to Step 3.
3. TYPE 5 and press [enter] to access the Tax Table Setup menu.
4. At the main screen, select the tax you would like to set (1-4) by TYPING the corresponding number using the numeric keys and pressing [enter]. After confirming, you will be automatically be taken to the first tax table setup entry required.
5. Enter the first minimum break value (step B in the worksheet) using the numeric keys.
6. Enter the summation of the "Regular" breakpoints (step C in the worksheet) using the numeric keys.
7. Enter the difference between the first tax amount and the last one in the "Regular" breakpoint sequence (step D in the worksheet) using the numeric keys.
8. Input the "Irregular" breakpoint values, in sequential order (step E in the worksheet) using the numeric keys and confirming with [enter]. As each value is entered, you will automatically be taken to the next value. Continue entering the breakpoints until you have entered them all.
9. Input the "Regular" breakpoint values, in sequential order (step F in the worksheet) using the numeric keys and confirming with [enter]. As each value is entered, you will automatically be taken to the next value. Continue entering the breakpoints until you have entered them all.
10. Your tax table is now programmed. PRESS [esc] to go back to the main menu.

IMPORTANT : To utilize any programmed tax tables, you must select "Tax Table" within main menu option 4) Tax Settings.

PROGRAMMING A CANADIAN(GST-PST) TAX RATE

The alpha 9500ML cash register can support the Canadian (GST-PST) tax system. As mentioned earlier in this section, the programming for this system mirrors that of the Add-on(US system). The exception with this is that you have to activate the Canadian tax system as well as set up any tax-on-tax options you require. When programming using the Canadian tax system, Tax 1 must be programmed as the GST tax, and taxes 2, 3, and 4 can be used as the PST taxes. Follow the Programming a Tax Type, Programming a Tax Rate(%), and Programming the Tax Limit on pages 31-32 to set up the GST (tax 1) and at least one PST(taxes 2, 3, or 4).

After setting up your GST and PST tax rates, you have to activate the Canadian tax system, and select the tax-on-tax settings using the Config. Options menu. These particular flags are 1005-1008. Use the Programming System Configurations Options section on pages 38-42 for help doing this.

Once you have activated the Canadian tax system, programmed a GST and PST tax rate, and applied any tax-on-tax values, you are ready to utilize the Canadian tax system. Make sure to apply both taxes to any applicable departments. If you require further assistance programming using the Canadian tax system, call Royal customer support at 1-888-266-9380 (in Canada).

2.11 PROGRAMMING DISCOUNTS, ADD-ONS and COUPONS

There are three different discount / add-on values available on your 9500ML cash register. These allow you to process customer coupons, give discounts(such as employee or senior citizen), as well as add-on a percentage to a transaction(perhaps). Each of these options can be preset to a particular value, or can be manually entered during a transaction. Programming of these items is available in the main programming menu under the heading Discount Settings.

PROGRAMMING THE PLUS PERCENTAGE(+%) KEY

Plus Percentage [%+] is used to add a percentage rate such as a service charge or gratuity to an individual item. The rate can be pre-programmed or manually entered. If desired, a procedure is offered so that the Plus Percentage amount is not added to the department totals on the Management Reports, for details see **Flag 0303**, Page 39.

The programming of the Plus Percentage [%+] key consists of two steps; presetting the Plus Percentage Rate (if desired) and selecting the Tax Status.

PROGRAMMING → 6) Discount Settings → +% ADD-ON%

ADD-ON%	Percentage	0.00%
	4 digits incl decimal	
	Input # then [enter]	

1. Turn the key to the "PRG" (PROGRAM) position.
2. If a PRG manager passcode has been programmed, TYPE the (PASSCODE #), then PRESS [enter] , or if you did not program a PROG manager passcode, go to Step 3.
3. TYPE 6 and press [enter] to access the Discount Settings menu.
4. Programming the Plus percentage rate is the first option.
5. Input the percentage rate (2 decimals) using the numeric keys. For example, to set 6% enter 600.
6. PRESS the [enter] key to finalize.
7. After programming the plus percentage rate you will automatically be taken to the plus percentage flag menu. Program those now or PRESS [esc] to exit to the main menu.

PROGRAMMING THE PLUS PERCENTAGE(+%) TAX STATUS

In addition to being able to program the plus percentage rate as a default value, you can program whether or not you want the tax rate to be charge when using it for operation. The default status of this is non-taxable.

PROGRAMMING → 6) Discount Settings → +% TX SET

#400000000TX	SET	0=Tax4 OFF	1=Tax4 ON
--------------	-----	------------	-----------

1. Turn the key to the "PRG" (PROGRAM) position.
2. If a PRG manager passcode has been programmed, TYPE the (PASSCODE #), then PRESS [enter] , or if you did not program a PROG manager passcode, go to Step 3.
3. TYPE 6 and press [enter] to access the Discount Settings menu.
4. PRESS [↑] to move to the +% tax setup menu.
5. Use the [←] and [→] keys to move to the tax # you want to apply. For example, if you would like to apply tax 2 to the plus percentage programming, then press [←] six times.
6. Once you reach the tax # that you want to program, PRESS either 1 or 0 using the numeric keys (follow the screen prompts for assistance) and confirm with [enter].
7. After programming the plus percentage tax status you will automatically be taken to the next flag menu. Continue on, and you will arrive at the -(discount) rate menu. Program this now or PRESS [esc] to exit to the main menu.

PROGRAMMING THE MINUS PERCENTAGE DISCOUNT(-%) KEY

Minus Percentage Discount [%-] is used to subtract a percentage rate such as an employee discount from an individual item. The rate can be pre-programmed or manually entered. If desired, a procedure is offered so that the Minus Percentage Discount amount is not subtracted from the department totals on the Management Reports, for details see **Flag 0303**, on Pages 39.

The programming of the Minus Percentage Discount key consists of two steps; presetting the Minus Percentage Discount rate (if desired) and selecting the Tax Status.

PROGRAMMING → 6) Discount Settings → -% DISCOUNT %

%	DISCOUNT%
	Percentage 0.00%
	4 digits incl decimal
	Input # then [enter]

1. Turn the key to the "PRG" (PROGRAM) position.
2. If a PRG manager passcode has been programmed, TYPE the (PASSCODE #), then PRESS [enter] , or if you did not program a PRG manager passcode, go to Step 3.
3. TYPE 6 and press [enter] to access the Discount Settings menu.
4. PRESS [↑] twice to move to the -% rate setup menu.
5. Input the percentage rate (2 decimals) using the numeric keys. For example, to set 6% enter 600.
6. PRESS the [enter] key to finalize.
7. After programming the discount rate you will automatically be taken to the discount flag menu. Program those now or PRESS [esc] to exit to the main menu.

PROGRAMMING THE MINUS PERCENTAGE DISCOUNT(-%) TAX STATUS

In addition to being able to program the minus percentage rate as a default value, you can program whether or not you want the tax rate to be charge when using it for operation. The default status of this is non-taxable.

PROGRAMMING → 6) Discount Settings → -% TX SET

%	#400000000TX SET
	SET
	0=Tax4 OFF
	1=Tax4 ON

1. Turn the key to the "PRG" (PROGRAM) position.
2. If a PRG manager passcode has been programmed, TYPE the (PASSCODE #), then PRESS [enter] , or if you did not program a PRG manager passcode, go to Step 3.
3. TYPE 6 and press [enter] to access the Discount Settings menu.
4. PRESS [↑] three times to move to the -% tax setup menu.
5. Use the [←] and [→] keys to move to the tax # you want to apply. For example, if you would like to apply tax 2 to the plus percentage programming, then press [→] six times.
6. Once you reach the tax # that you want to program, PRESS either 1 or 0 using the numeric keys (follow the screen prompts for assistance) and confirm with [enter] .
7. After programming the minus percentage tax status you will automatically be taken to the next flag menu. Continue on, and you will arrive at the Coupon value menu. Program this now or PRESS [esc] to exit to the main menu.

PROGRAMMING THE COUPON(-) KEY

The Coupon Discount (CPN) key is used to subtract a specific amount from an individual item. This function can be performed in the middle of a transaction or by itself in a transaction.

The programming of the Coupon Discount [-/CPN] key consists of three steps; programming a preset amount, adjusting the Tax Status and selecting a High Digit Lock Out (HDLO).

If desired, a procedure is offered so that the Coupon amount is not subtracted from the department totals on the Management Reports, for details see Flag 0304, on Pages 39.

PROGRAMMING → 6) Discount Settings → CPN AMOUNT

CPN	AMOUNT
	CPN AMNT 0.00
	4 digit maximum

1. Turn the key to the "PRG" (PROGRAM) position.
2. If a PRG manager passcode has been programmed, TYPE the (PASSCODE #), then PRESS [enter] , or if you

as needed.

A number of system configuration options (known as FLAGS) are offered on this cash register. They are preset at the factory to accommodate the most commonly used selections. Each flag option can be changed or updated at any time

2.12 PROGRAMMING SYSTEM CONFIGURATION OPTIONS(FLAGS)

1. Turn the key to the "PRG" (PROGRAM) position.
2. If a PRG manager passcode has been programmed, TYPE the (PASSCODE #), then PRESS [enter] , or if you did not program a PROG manager passcode, go to Step 3.
3. TYPE 6 and press [enter] to access the Discount Settings menu.
4. PRESS [↓] six times to move to the Coupon/- HALO menu.
5. Input the coupon HALO (7 digit maximum) using the numeric keys. For example, to set \$10.00 enter 1000.
6. PRESS the [enter] key to finalize.
7. After programming the coupon halo value you will automatically be taken to the plus percentage (+%) menu. Program that now or PRESS [esc] to exit to the main menu.

```

OPN COUPON HALO
CPN HALO 0.00
7 digit maximum
Input # then [enter]

```

PROGRAMMING → 6) Discount Settings → CPN AMOUNT

After programming the coupon preset value and tax status, you can also program a high-amount lock out value(HALO). When programmed, your cash register will not allow coupon entries higher than this amount to be entered.

PROGRAMMING THE COUPON(-) HALO AMOUNT

1. Turn the key to the "PRG" (PROGRAM) position.
2. If a PRG manager passcode has been programmed, TYPE the (PASSCODE #), then PRESS [enter] , or if you did not program a PROG manager passcode, go to Step 3.
3. TYPE 6 and press [enter] to access the Discount Settings menu.
4. PRESS [↓] five times to move to the coupon tax setup menu.
5. Use the [←] and [→] keys to move to the tax # you want to apply. For example, if you would like to apply tax 2 to the plus percentage programming, then press [→] six times.
6. Once you reach the tax # that you want to program, PRESS either 1 or 0 using the numeric keys (follow the screen prompts for assistance) and confirm with [enter] .
7. After programming the coupon tax status you will automatically be taken to the next flag menu. Continue on, and you will arrive at the Coupon HALO amount. Program this now or PRESS [esc] to exit to the main menu.

```

OPN #400000000TX SET
SET
0=Tax4 OFF
1=Tax4 ON

```

PROGRAMMING → 6) Discount Settings → CPN TX SET

In addition to being able to program the coupon amount as a default value, you can program whether or not you want the tax rate to be charge when using it for operation. The default status of this is non-taxable.

PROGRAMMING THE COUPON TAX STATUS

3. TYPE 6 and press [enter] to access the Discount Settings menu.
4. PRESS [↓] four times (or the page down key twice) to move to the Coupon/- amount menu.
5. Input the coupon amount (4 digit maximum) using the numeric keys. For example, to set \$10.00 enter 1000.
6. PRESS the [enter] key to finalize.
7. After programming the coupon value you will automatically be taken to the coupon tax status flag menu. Program those now or PRESS [esc] to exit to the main menu.

CHAPTER 2: ADVANCED PROGRAMMING

For example, you can select the decimal place you would like to use, the rounding method, and more by using the system configuration options(flags). This section of your user's manual will help you do so. The table below shows all of the available flags, broken down by flag # and option number. To easily access a particular flag you can enter this number.

While you are viewing a flag, you will see the flag and option numbers(as well as the current setting) displayed in the upper right corner of the screen. This will help you navigate through the options, as well as determine which settings you need to change. Most flags have 8 sections, which can be scrolled through by using the [→] and [←] keys. To move between flags, use the [↑] and [↓] or [pg up] and [pg down] keys.

NOTE: Most flags have been factory preset at "0". They only need to be programmed if you wish to change any option from "0" to "1".

Flag #	Displayed Option	Explanation
0101	Decimal Select: 0=NONE 1=0.0 2=0.00 3=0.000	Select the decimal system you would like to use
0102	Date format: 0=YYYYMMDD 1=MMDDYYYY 2=DDMMYYYY	Select the Date print format
0201	Tax / % Rounding: 0=NONE 5=5/4 6=6/5 9=ALWAYS UP round everything UP	Select the Rounding method : choose 0 for rounding DOWN always, choose 5 for standard 5 up/ 4 down rounding, choose 6 for 6 up / 5 down, and 9 to round everything UP
0202	Rounding decimal digit : 0=LAST 1=FIRST	Select the decimal that gets rounded during a calculation.
0301	Allow clerk switch while in a trans. ? 0=No 1=Yes	Select whether or not you allow the switching of clerks while a transaction is active.
0302	Allow over tender for charge/credit 0=No 1=Yes	Select whether or not you allow over-rings for credit and charge transactions.
0303	+/-% included in report? (DEPT) 0=No 1=Yes	Select whether you want the discount and plus % totals to be included in department reports.
0304	Coupon/- totals incl. in DEPT rpt.? 0=No 1=Yes	Select whether you want the coupon totals to be included in department reports.
0305	Hourly report displays tit? 0=Item # 1=Trans #	Select whether you want the hourly report to print the item total or transaction total.
0306	Net sales total includes RTN/VOID ? 0=Yes 1=No	Toggle if the Net sales shown on reports includes Return and Void amounts or not.
0307	Clerk sales tit includes RTN/VOID ? 0=Yes 1=No	Toggle if the clerk sales shown on reports includes Return and Void amounts or not.
0401	Position of footer mess. 0=After header 1=End Rpt	Select where the footer message prints. Either after the header, or at the end of the receipt.
0402	Position of Time & Date? 0=End Rcpt. 1=Top Rcpt.	Select where the time and date print, either at the beginning or end of the receipt.
0403	Duplicate report copy allowed? 0=No 1=Yes	Choose whether or not to allow the printing of a duplicate Z report.
0404	Reset receipt # after daily rpt? 0=No 1=Yes	Reset the transaction / receipt # after printing the daily(Z) report ?
0405	Hold Dept. Shift between items ? 0=No 1=Yes	Toggle whether or not the department shift key status should be saved between entries when programming an alphanumeric message or title.
0406	Hold Dept. Shift between trans.? 0=No 1=Yes	Toggle whether or not the department shift key status should be saved between transactions.
0407	Duplicate receipt copy allowed? 0=No 1=Yes	Allow the printing of duplicate receipts or not.

0408	Allow keyboard layout to be changed? 0=No 1=Yes	Allow the keyboard layout to be changed?
0501	Receipt Printing 0=per line 1=after final	When the receipt is active, does it print per line or after finishing the transaction.
0502	Include tax in taxable \$(VAT mode) 0=Yes 1=No	When using VAT tax mode, choose if the tax amount be added to the taxable amount on the receipt.
0503	Tax amounts printed : 0=Total tax 1=Each Rate	Select if the tax rates print as a total or individually on receipts.
0504	Print taxable \$'s on receipt? 0=No 1=Yes	Select whether or not the taxable dollar value prints on the receipt.
0505	Print taxable symbol for DEPT/PLU? 0=Yes 1=No	Turn ON / OFF the taxable symbol for department and PLU entries.
0506	Print ind. tax % rate on receipt? 0=No 1=Yes	Select whether or not the individual tax rates (1,2,3,4) print separately on the receipt.
0507	Allow negative entries? (qty or amt) 0=Yes 1=No	Select whether or not negative values are allowed to be entered during sales registration.
0508	Force Z printing when report full? 0=No 1=Yes	Choose whether the cash register forces you to clear the Z report when its memory is full.
0601	Print receipt # ? (R&J) 0=Yes 1=No	Print the receipt / transaction number on a receipt or not.
0602	Print time on receipt? (R&J) 0=Yes 1=No	Print the time on the receipt or not.
0603	Print date on receipt? (R&J) 0=Yes 1=No	Print the date on the receipt or not.
0604	Print Header on receipt? 0=Yes 1=No	Print the header on the receipt or not.
0605	Print sales quantity on receipt? 0=Yes 1=No	Print the item quantities on the receipt or not.
0606	Print Grand Total in reports? 0=Yes 1=No	Print the grand total amount on the reports or not.
0607	Require Clerk Login when mode changes? 0=No 1=Yes	Choose whether or not the active clerk is logged out when switching mode positions.
0608	Require Clerk Log after each trans.? 0=No 1=Yes	Choose whether or not the active clerk is logged out between transactions.
0701	Round when [total] pressed? 0=Yes 1=No	Select if the rounding calculation is computed when the amount tend key is pressed after a transaction.
0702	Round when [check] pressed? 0=Yes 1=No	Select if the rounding calculation is done when the check key is pressed after a transaction.
0703	Round when [charge] pressed? 0=Yes 1=No	Select if the rounding calculation is done when the charge key is pressed after a transaction.
0704	Round when [subtl] pressed? 0=Yes 1=No	Select if the rounding calculation is done when the subtotal key is pressed during a transaction.
0705	Print commercial ticket after ret.? 0=No 1=Yes	Choose whether or not a commercial ticket should print immediately after a sales receipt.
0706	PLU entry, use PLU # or barcode? 0=PLU # 1=CODE	For PLU registration, use the PLU sequence number or the barcode number.
0707	Journal message position 0=Top 1=Bottom	Designate whether the Journal Message prints on the top or bottom of the receipt
0708	Receipt ON / OFF key active ? 0=Yes 1=No	Allow the receipt On / Off key to be used in sales registration mode.

0801	<p>NOTE: This flag is only active if the rounding method is changed.</p> <p>4=5/4 9=DWN 2=SWS 12=DAN</p> <p>Roundng(subtotal):0=UP</p>	<p>NOTE: Flag 0901 and 0801 are linked. If you plan on using either Swiss or Danish rounding methods please set both to the same value.</p> <p>Select which digit in a decimal is round, choices are: NONE or first digit, LAST and the last digit, SWISS, and DANISH</p>	<p>NOTE: This flag is only active if the rounding method is changed.</p> <p>UP would round all values UP.</p> <p>5/4 rounds 5+ up and 4- down.</p> <p>DWN would round all values down.</p> <p>SWS uses swiss mode where 0-2 rounds down, 3-7 becomes 5, and 8-9 rounds up.</p> <p>DAN is danish mode where 0-.12 round down, .13-.37 become rounded up.</p>	0901	<p>Roundng(digit): 0=NONE</p> <p>1=LAST 2=SWISS 3=DANISH</p>
1001	<p>Allow Swiss rounding method? 0=NO 1=YES</p>	<p>Toggle ON / OFF the swiss rounding method.</p>		1001	<p>Allow dump reports? (PLU,DEPT,ETC) 0=No 1=Yes</p>
1002	<p>Hold CAPS during name input? 0=Yes 1=No</p>	<p>Change whether or not the CAPS key will hold between characters when programming a name.</p>		1002	<p>Allow programming dump reports to be printed by using the [print] key in the programming menus.</p>
1003	<p>Enable barcode learning function? 0=No 1=Yes</p>	<p>Allow use of the barcode learning function during sales registration mode.</p>		1004	<p>Canadian Tax System active? 0=No 1=Yes</p>
1005	<p>Include Tax1(GST) in Tax2(PST)? 0=Yes 1=No</p>	<p>Enable Tax-on-Tax system for Tax2(PST)</p>		1006	<p>Include Tax1(GST) in Tax3(PST)? 0=Yes 1=No</p>
1007	<p>Include Tax1(GST) in Tax4(PST)? 0=Yes 1=No</p>	<p>Enable Tax-on-Tax system for Tax3(PST)</p>		1008	<p>Include Tax1(GST) in Tax4(PST)? 0=Yes 1=No</p>
1101	<p>Price/Weight barcode 0=N/A 1=4/5 code/price</p>	<p>When using the price / weight barcode function use a barcode with a 4 digit item code and 5 digit price / weight code.</p>		1102	<p>Price/Weight barcode 0=N/A 1=4/6 code/price</p>
1103	<p>Price/Weight barcode 0=N/A 1=5/4 code/price</p>	<p>When using the price / weight barcode function use a barcode with a 5 digit item code and 4 digit price / weight code.</p>		1104	<p>Price/Weight barcode 0=N/A 1=6/4 code/price</p>
1105	<p>Barcode type 02 set for? 0=Price 1=Weight</p>	<p>When using the price / weight barcode function set barcode type 02 as price or weight input.</p>		1106	<p>Barcode types (20-22)set for? 0=Price 1=Weight</p>
1106	<p>Barcode types (23-25)set for? 0=Price 1=Weight</p>	<p>When using the price / weight barcode function set barcode types 23-25 as price or weight input.</p>		1107	<p>Barcode types (23-25)set for? 0=Price 1=Weight</p>
1108	<p>Allow price/weight barcodes? 0=No 1=Yes</p>	<p>Allow the use of price / weight barcodes or not.</p>		1201	<p>Cash Alarm active? 0=No 1=Yes</p>
	<p>Toggle the Cash Alarm as active or not.</p>				

No.	Function	No.	Function	No.	Function	No.	Function
01	VOID	2F	NS	8C	DEPT12	01	Function
02	RETURN	30	CHECK2	8D	DEPT13	02	Function
03	TAX EXEMPT	31	CHECK3	8E	DEPT14	03	Function
04	TAX1	32	CHECK4	8F	DEPT15	04	Function
05	TAX2	33	CHARGE2	90	DEPT16	05	Function
06	TAX3	34	CHARGE3	91	DEPT17	06	Function
07	TAX4	35	CHARGE4	92	DEPT18	07	Function
08	RA	36	CREDIT2	93	DEPT19	08	Function
09	PO	37	CREDIT3	94	DEPT20	09	Function
0A	CLEERK	38	CREDIT4	95	DEPT21	0A	Function
0B	-%	39	TAX FORCE	96	DEPT22	0B	Function
0C	+	80	DEPT	97	DEPT23	0C	Function

To adjust the keyboard and program a different key, you need to know its function code. Please see the table on the next page for a listing of the available functions and their respective codes.

For added security, you can lock this function in the **Config. Options (flag)** menu under flag 0408.

The alpha 9500ML allows you the ability to customize your keyboard in the manner that serves your business best. For example, if you do not need the three charge keys that are pre-programmed on the keyboard, you can adjust one of the se to be a foreign currency (FC) key. Programming of the keyboard is available in the **main programming menu** under the heading **Keyboard Layout**.

2.13 ADJUSTING THE KEYBOARD LAYOUT

1. Turn the key to the "PRG" (PROGRAM) position.
2. If a PRG manager passcode has been programmed, TYPE the (PASSCODE #), then PRESS [enter], or if you did not program a PROG manager passcode, go to Step 3.
3. TYPE 7 and press [enter] to access the configuration options (flags) menu.
4. Flag 1, option 1 will be shown by default. If you would like to access a particular flag, PRESS [input], TYPE the flag number (XXXX) and then [input]. You can also PRESS the arrow or [pg up] and [pg down] keys to reach the particular flag you wish to set.
5. Using the screen prompt as a guide, enter the value for your desired setting and press [enter].
6. Repeat steps 4-5 to program any other flags needed.
7. After programming a flag, you will automatically be taken to the flag option in the sequence. Program this now or PRESS [esc] to exit to the main menu.

CONFIG OPTIONS 0101=2

Decimal Select: 0=NONE
1=0.0 2=0.00 3=0.000

Input # then [enter]

Flag and setting value indicator

PROGRAMMING → 7) Config. Options → Flags

1202	Use half-height fonts ? 0=Yes 1=No	Use half-height(compressed) characters for printing or not.
1203	Half-height fonts print rpt. only? 0=No 1=Yes	If half-height fonts are used, apply only to reports or not.
1204	TrainMd prints training 0=word 1=symbol	When training mode is activated, select whether the word TRAINING prints on a receipt, or only the training symbol.

0D		24	CPN	81	DEPT01	98	DEPT24
0E	CLR	25	X/IME	82	DEPT02	99	DEPT25
0F	PLU ALT	26	DEPT SHIFT	83	DEPT03	9A	DEPT26

PROGRAMMING A KEYBOARD KEY

PROGRAMMING → 8) Keyboard Layout → Key Layout

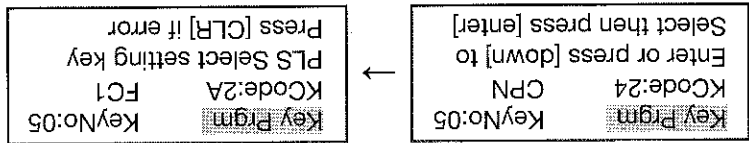

1. Turn the key to the "PRG" (PROGRAM) position.

2. If a PRG manager passcode has been programmed, TYPE the (PASSCODE #), then PRESS [enter] ; or if you

did not program a PRG manager passcode, go to Step 3.

3. TYPE 8 and press [enter] to access the Keyboard Layout menu.

4. PRESS the key on the keyboard you would like to change. For example, if you would like to reprogram the

[coupon] key, press it now.

5. TYPE the code of the function you wish to set this key to using the numeric and alpha keys. For example, if you

would like to apply the FC key, enter 2A.

6. If you make a mistake, press the [clear] key to reset. You can also scroll through the available function keys by

using the arrows.

7. PRESS the [enter] key to finalize.

8. After finalizing, the screen will change to reflect the updated key. Repeat steps 4-7 to program another key, or

PRESS [esc] twice to exit to the main menu.

2.14 PROGRAMMING THE TRANSACTION WORDS

Transaction words are linked to the function keys and they are printed on receipts and reports.

The length of transaction word is limited up to eight regular size characters or four double size characters. They can be changed to desired words very easily. Please see the chart below for the required codes and explanations for the available keys. If you need help programming the alphanumeric descriptions, see SETTING ALPHANUMERIC DESCRIPTIONS on page 18.

Function Code	Default Text	Explanation
01	DEPT TTL	Department Total
02	NOTXBL	Non-taxable
03	TXBL-1	Taxable 1
04	TXBL-2	Taxable 2
05	TXBL-3	Taxable 3
06	TXBL-4	Taxable 4
07	TXBL-TTL	Total Taxable Amount
08	TAX-1	Tax 1 Amount
09	TAX-2	Tax 2 Amount
10	TAX-3	Tax 3 Amount
11	TAX-4	Tax 4 Amount
12	TAX	Total Tax Amount Applied
13	+%G	Gross Plus Percentage Amount

14	+%N	Net Plus Percentage Amount
15	TOTAL	Total Amount for a transaction
16	GROSS	Gross amount on a Report
17	RETURN	Return / Refund
18	COUPON G	Coupon Applied on a Gross
19	COUPON N	Coupon Applied on an Item
20	-%G	Gross Minus Percentage Amount
21	-%N	Net Minus Percentage Amount
22	ROUND	Rounding
23	NET TL	Net Total
24	CASH	Cash Total / Payment
25	CHECK	Check Total / Payment
26	CHECK2	Check2 Total / Payment
27	CHECK3	Check3 Total / Payment
28	CHECK4	Check4 Total / Payment
29	CHARGE	Charge Total / Payment
30	CHARGE2	Charge2 Total / Payment
31	CHARGE3	Charge3 Total / Payment
32	CHARGE4	Charge4 Total / Payment
33	CREDIT	Credit Total / Payment
34	CREDIT2	Credit2 Total / Payment
35	CREDIT3	Credit3 Total / Payment
36	CREDIT4	Credit4 Total / Payment
37	NOSALE	No Sale Transaction
38	R/A CA	Received on Account-Cash
39	P/O CA	Cash Paid Out
40	CAID	Cash In Drawer
41	CKID	Check In Drawer
42	CPID	Coupon In Drawer
43	CREDIT ID	Credit In Drawer
44	NRGT	Net Running Grand Total
45	MSC-V	Minus Item Void
46	CASH TD	Cash Tendered
47	CHECK TD	Check Tendered
48	CHECK2 TD	Check2 Tendered
49	CHECK3 TD	Check3 Tendered
50	CHECK4 TD	Check4 Tendered
51	CREDIT TD	Credit Tendered

52	CREDIT2 TD	Credit2 Tendered
53	CREDIT3 TD	Credit3 Tendered
54	CREDIT4 TD	Credit4 Tendered
55	VOID	VOID total
56	TAXTOTAL	VAT Tax Total
57	RPRT CNT	Reprint Counter
58	SUB-TTL	Subtotal
59	CHANGE	Change tendered
60	-VOID-	Void entry
61	RETURN	Return total
62	ITEM CT	Item / Quantity counter
63	R/A	Received On Account
64	P/O	Paid Out
65	DPBL	
66	CHG (FC)	Foreign Currency Change
67	CREDIT NO	Credit number / counter
68	FCID	Foreign Currency In-Drawer
69	FCID2	Foreign Currency2 In-Drawer
70	FCID3	Foreign Currency3 In-Drawer
71	FCID4	Foreign Currency4 In-Drawer
72	FC-CG	
73	CANCEL	Transaction Cancelled
74	CHECK	Check Report Total
75	CHECK2	Check2 Report Total
76	CHECK3	Check3 Report Total
77	CHECK4	Check4 Report Total
78	CHARGE2	Charge2 Report Total
79	CHARGE3	Charge3 Report Total
80	CHARGE4	Charge4 Report Total
81	CREDIT2	Credit2 Report Total
82	CREDIT3	Credit3 Report Total
83	CREDIT4	Credit4 Report Total
84	CKID2	Check2 In Drawer
85	CKID3	Check3 In Drawer
86	CKID4	Check4 In Drawer
87	CREDIT2	Credit2 In Drawer
88	CREDIT3	Credit3 In Drawer
89	CREDIT4	Credit4 In Drawer

Changing Transaction Words

PROGRAMMING → 9) Transaction Words → TRANSACTION

[A to 'O'] Enter alpha characters: CHARGE [A to 'O']	[A to 'O'] Enter alpha characters: VISA [A to 'O']
---	---

1. Turn the key to the "PRG" (PROGRAM) position.
2. If a PRG manager passcode has been programmed, TYPE the (PASSCODE #), then PRESS [enter], or if you did not program a PRG manager passcode, go to Step 3.
3. TYPE 9 and press [enter] to access the Transaction Words menu.
4. PRESS the code for the key you would like to change. For example, if you would like to reprogram the [charge] key, press 29 now.
5. If you make a mistake, press the [clear] key to reset. You can also scroll through the available transaction words by using the arrow keys.
6. PRESS the [enter] key to finalize.
7. After finalizing, the screen will change to reflect the updated description. Repeat steps 4-7 to program another key, or PRESS [esc] to exit to the main menu.

2.15 PROGRAMMING HEADERS AND FOOTERS

A 5 line store header and footer can be programmed to print on customer receipts. These two messages can print separately (beginning and end of receipt) or together, which gives you a maximum of 10 lines, each line 24 characters (normal size) or 12 characters (double width). See Config. Options flag 0401.

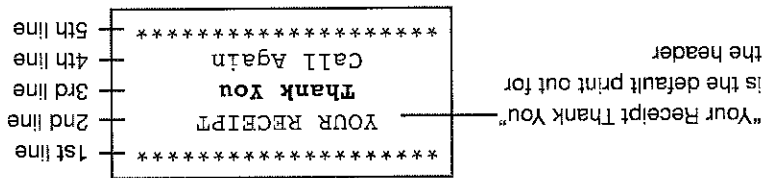

Make a copy of the attached blank Store Logo Worksheet for future changes or revisions to your logo. The header and footer message will only print on the receipt printer. Please follow these simple steps to program your logo:

Step 1: First, write out your store name and logo message you wish to program. For example, to program the following store logo message:

INTERNATIONAL COFFEES
 999-555-1111
 22 EAST MAIN STREET
 OPEN 7AM TO 6PM
 COFFEES OF THE WORLD

STORE LOGO WORKSHEET

	1st line
	2nd line
	3rd line
	4th line
	5th line
	6th line
	7th line
	8th line
	9th line
	10th line

Step 2: After writing out your message, next count the number of characters on each line.

INTERNATIONAL COFFEES	21
999-555-1111	12
222 EAST MAIN STREET	20
OPEN 7AM TO 6PM	15
COFFEES OF THE WORLD	20
Per Line (including spaces)	

Step 3: Next, fill in the chart, filling in extra unused characters with blank spaces. Note that blank spaces were added at the beginning and end of each line in order to **CENTER** the logo.

1st line	00	00	I	N	T	E	R	N	A	T	I	O	N	A	L	00	C	O	F	F	E	S	00
2nd line	00	00	00	00	00	00	00	9	9	-	5	5	5	-	1	1	1	1	00	00	00	00	00
3rd line	00	00	2	2	00	E	A	S	T	00	M	A	I	N	00	S	T	R	E	E	T	00	00
4th line	00	00	00	00	00	0	F	E	N	00	7	A	M	00	T	O	00	6	P	M	00	00	00
5th line	00	00	C	O	F	F	E	S	00	0	F	00	T	H	E	00	W	O	R	L	D	00	00

PROGRAMMING A HEADER / FOOTER MESSAGE

After setting up your message using the worksheet, please follow these steps to program a header or footer message. You can turn off the header / footer messages and not have them print by using the **flags (Config. Options)**.

PROGRAMMING → 10) Receipt Header → Header

```

HEADER (ABCD) 02LN
YOUR RECEIPT
Enter alpha characters:
[P. to Z] WIDE
    
```

OR PROGRAMMING → 11) Receipt Footer → Footer

```

FOOTER
length
Lines value: 0~5
Input # then [enter]
    
```

1. Turn the key to the "PRG" (PROGRAM) position.
2. If a PRG manager passcode has been programmed, TYPE the (PASSCODE #), then PRESS [enter] , or if you did not program a PRG manager passcode, go to Step 3.
3. TYPE 10 or 11 and press [enter] to access the header or footer menu.
4. The first screen will ask you to enter the number of lines you wish to print. For the header, this value can be between 2-5, and for the footer, it can be between 0-5. You can also use the arrow and page up / down keys to move through the line menus.
5. Once you enter the number of lines, you will automatically be taken to the first line available. The current setting for this line will be shown. You can immediately begin entering your output from the programming worksheet now and it will clear the old value. When you are finished setting a line, PRESS the [enter] key to finalize.
6. After programming a particular line and confirming with [enter] you will be taken to the next line. Program this now or PRESS [esc] to exit to the main menu.

2.16 PROGRAMMING THE FOREIGN CURRENCY(FC) KEY

You can specify up to four foreign currencies to accept as payment when you total sales and program the exchange rate for when you accept this currency. This is useful if you are working in a multiple currency situation and want to accept another currency, such as stores near a border with another country. You can set the default conversion calculation (FC to local currency) so that when you use this key, the cash register calculates the correct change. You can also give the

NOTE: Updating the cash register software requires a **FULL SYSTEM CLEAR**, which will erase any sales, transaction, and programming data on your cash register. It would be beneficial to back-up and save any data you do not wish to lose if performing this procedure.

From time to time, new software versions for your alpha9500ML may become available. If available, they can be found on the Royal website(www.royal.com) under the **SUPPORT** tab. If updates are available, you can use a USB based drive or device to download these to your cash register.

2.18 UPDATING THE CASH REGISTER SOFTWARE

1. Turn the key to the "PRG" (PROGRAM) position.
2. If a PRG manager passcode has been programmed, TYPE the (PASSCODE #), then PRESS [enter] , or if you did not program a PROG manager passcode, go to Step 3.
3. TYPE 15 press [enter] to access the journal message menu.
4. The first screen will ask you to enter the number of lines you wish to print. For the journal message, this can be from 0-10 lines. You can also use the arrow and page up / down keys to move through the line menus.
5. Once you enter the number of lines, you will automatically be taken to the first line available. The current setting for this line will be shown. You can immediately begin entering your output from the programming worksheet now and it will clear the old value. When you are finished setting a line, PRESS the [enter] key to finalize.
6. After programming a particular line and confirming with [enter] you will be taken to the next line. Program this now or PRESS [esc] to exit to the main menu.

JOURNAL MESS	LINE
Length	0
# of lines: 0-10	
Input # then [enter]	

PROGRAMMING → 15) Journal Message → Journal Mess.

To program this message, use the worksheet provided in the Programming a Header / Footer message section on page 47.

In addition to the Header and Footer messages you can print on the receipts, you can also create a 10-line customizable message to print on the journal tape. You can also adjust the positioning of this message and whether or not it prints by using the **Config. Options (flags)**.

2.17 PROGRAMMING A JOURNAL MESSAGE

- You can program this now or PRESS [esc] to exit to the main menu.
1. Turn the key to the "PRG" (PROGRAM) position.
 2. If a PRG manager passcode has been programmed, TYPE the (PASSCODE #), then PRESS [enter] , or if you did not program a PROG manager passcode, go to Step 3.
 3. TYPE 12 and press [enter] to access the FC Settings menu.
 4. FC 1 conversion rate will be displayed by default. If you would like to move to another setting or FC, use the arrow or page up / down keys.
 5. The first option is to set the conversion rate (FC to local, 8 digits max). Enter this using the numeric keys. For example, if you want to enter 10 Pesos for one dollar, PRESS 100000.
 6. PRESS the [enter] key to confirm.
 7. After confirming the percentage rate, you will automatically be taken to the programming an FC name menu.

FC01 CONV RATE	FC to \$:	0.0000
	Include decimal 8 digits	
	Input # then [enter]	

PROGRAMMING → 12) FC Settings → FC

NOTE: The 9500ML default keyboard layout does NOT include an FC key. If you would like to use this function, please program at least one FC key on your keyboard. For help in changing the keyboard keys, see Adjusting the keyboard layout on pages 43-44.

FC keys a text description, such as PESOS to help signify what is being accepted.

For assistance, or to answer any questions regarding this procedure, please contact Royal customer service.

PROGRAMMING → 16) Software Update → SOFT_UPDATE

SOFT_UPDATE
Insert USB drive, press
[enter] to start update,
[esc] to cancel / exit.

1. Turn the key to the "PRG" (PROGRAM) position.
2. If a PRG manager passcode has been programmed, TYPE the (PASSCODE #), then PRESS [enter] , or if you did not program a PRG manager passcode, go to Step 3.
3. TYPE 16 press [enter] to access the Software Update screen.
4. Insert a USB based device, that has the new software version saved to it. Press [enter] to begin the download. You will see a warning message, and shortly after the clerk display will go black. This is normal.
5. On your USB device, the communication / activity light will flash or flicker to confirm that a download is being made. Allow a few minutes for this activity light to stop flashing.
6. Once the flashing is finished, your 9500MIL should have downloaded the software. You can remove the USB device now.
7. To force this software to take effect, you must re-initialize the cash register. See **Initial Set-up** on page 6 for more information. To initialize the software, turn the key to the "PRG" position and remove power from the cash register.
8. Supply power while holding down the [clear] key to perform a FULL SYSTEM CLEAR.
9. The cash register should initialize, and print a confirmation of System clear.

- System Options
- Department Settings
- PLU Settings
- Tax Rate Settings
- Discount / Add-On Settings
- Configuration Options(flag) settings
- Keyboard Layout
- Transaction Words
- Receipt Header / Footer
- Foreign Currency(FC) Settings
- Clerk Settings
- Manager Passcodes
- Journal Message

Programming confirmation(dump) reports allow you to check and track the programming of a specific function on your cash register. For example, you can run a department confirmation report to print all the programmed information for your departments. The following dump reports are available :

3.1 PRINTING / RUNNING DUMP REPORTS

Report name	X1	X2	Z1	Z2
	(Daily)	(Periodic)	(Daily)	(Periodic)
Full Group Dept Sales	√	√		
Full Department Sales	√	√		
Individual PLU Sales	√	√		
Full PLU Sales	√	√	√	√
IND. PLU LINK to DEPT	√	√		
FULL PLU LINK to DEPT	√	√		
INDIVIDUAL CLERK	√	√	√	√
ALL CLERK SALES	√	√	√	√
FULL REPORT	√	√	√	√
DRAWER REPORT	√	√	√	√
HOURLY REPORT	√		√	
CASH DECLARATION			√	
TRAINING REPORT	√	√	√	√

The cash register is designed to maintain totals of all transaction data. Transaction data is maintained in the memory of the cash register as long as the system is plugged in and/or the battery back-up system is in effect. This data can be obtained in the "X" or "Z" positions. The read-out for the Management Reports is the same whether it is taken in the "X" or "Z" positions, the only difference is that the totals are reset to zero after a "Z" position reading.

The 9500ML cash register has a wide variety of reports available. These reports range from sales reports(clerk, hourly, daily, etc.) to programming confirmation reports(Dump Reports). In addition to being able to print these reports on the cash register tape, you can also display the current totals on-screen(most reports), as well as save them to a USB drive / device(most reports). This allows you to do a periodical check of the cash register data, or transferred to a PC for saving.

CHAPTER 3 : RUNNING, CLEARING, AND SAVING REPORTS

CHAPTER 3: RUNNING, CLEARING AND SAVING REPORTS

For most of these reports, only the programmed items will be printed, for example, if you print a department settings re-ports and have only programmed 10 departments, only the 10 departments will print. A few dump report examples follow.

PLU PRESET	
PLU NUMBER	1
PLU CODE NUMBER	0001
PLU DESCRIPTION	APPLE
PLU PRICE	1.99
LINKED TO DEPT#	01
PLU NUMBER	2
PRICE	2.50
LINK#	02
MILK	
0002	
PRICE	3.99
LINK#	03
BREAD	
0003	
PRICE	0.01
LINK#	01
0004	
PLU 0004	

DEPT PRESET	01	DEPT1	PRICE	1.99	PRE-SET PRICE
		DEPT02	PRICE	2.50	DEPARTMENT FLAG
		DEPT03	PRICE	3.00	OPTIONS
		DEPT04	PRICE	0.00	
		DEPT05	PRICE	0.00	
		DEPT06	PRICE	0.00	
		DEPT07	PRICE	0.00	
		DEPT08	PRICE	0.00	
		DEPT09	PRICE	0.00	
		DEPT10	PRICE	0.00	
			PRICE	0.00	
			PRICE	0.00	

DEPARTMENT NAME
PRE-SET PRICE
DEPARTMENT FLAG
OPTIONS

NOTE: If a description has been programmed, the name will print instead of the Dept. #

PRINTING A PROGRAMMING CONFIRMATION(DUMP) REPORT

PROGRAMMING → Select Option to print → [print]

1. Turn the key to the "PRG" (PROGRAM) position.
2. If a PRG manager passcode has been programmed, TYPE the (PASSCODE #), then PRESS [enter], or if you did not program a PRG manager passcode, go to Step 3.
3. TYPE the number of the option you want to print and press [enter]. For example, if you would like to print a department confirmation report, press 2 and then [enter].
4. From the main page of the individual menu option, press [print] to print the dump report. You can interrupt the printing at any time by pressing the [feed] key.
5. After printing is completed, press [esc] to go back to the main menu.
6. Repeat steps 3-5 for any other dump reports you wish to print.

3.2 PRINTING / VIEWING X REPORTS

There are two types of readings that can be taken in the "X" position: a "Daily (X1)" reading and a "Periodic(X2)" reading. Note: To prevent accidental printing of the "X" reading, a Manager Password can be set. Once the password is set, an "X" report will not print in the "X" position until the password is typed.

"DAILY(X1)" READING - Commonly known as a "mid-day" reading; prints an accumulation of transaction data and is not reset to zero unless a "Daily Z" reading is taken. Use this position to print periodic readings of transaction totals during the course of the day.
"PERIODIC(X2)" READING - Commonly known as a "mid-week" or "mid-month" reading; prints an accumulation of transaction data and is not reset to zero unless a "Periodic Z" reading is taken. Use this position to print periodic readings of transaction totals during the course of several days. The "Periodic(X2)" report is only available in the "X" position.

Most of the reports available in "X" mode are mirrored in "Z" mode, however "X" mode is the only mode that allows you to view the report totals on-screen.

X MANAGEMENT REPORTS AVAILABLE FOR PRINTING

There are a total of nine different kinds of reports available in X mode:

- FULL SALES REPORT** - Includes totals of departments, tax, net sales, voids, returns, coupons, refunds, minus percentage, plus percentage, receipts-on-account, no-sale activity, paid out, cash, check, and charge.
- DEPT SALES REPORT** - Lists total quantity and cost of each department number rung up.
- DEPT GROUP REPORT** - Prints sales totals by designated department group.
- PLU SALES REPORT** - Lists the total quantity and cost of each PLU number rung up.
- LINKED PLU REPORT** - Prints the total quantity and cost of each PLU number rung up by department, or of a specific department.
- CLERK SALES REPORT** - Exclusively prints total sales amounts of each Clerk Number operated, tax total or no-sale counter.
- HOURLY REPORT** - Provides total sales amounts rung up each hour.
- CASH-IN-DRAWER REPORT** - simply tells you how much cash is in the drawer at the time of the report.
- TRAINING REPORT** - Prints the total sales rung up in training mode. This report is only available in X mode.

PRINTING X REPORTS

X → 1) Daily or 2) Periodic → Desired report

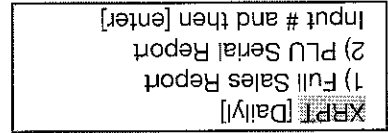

1. Turn the key to the "X" position.
 2. If an X passcode has been programmed, TYPE the (PASSCODE #), then PRESS [enter] , or if you did not program a X passcode, go to Step 3.

3. Use the numeric keys to select the type of report you would like to print (Daily or Periodic) and confirm with [enter].

4. TYPE the number of the report you want to print and press [enter] . For example, if you would like to print the daily full sales report, press 1 and then [enter] . You can scroll through the available report options by using the page up and page down keys.

5. After pressing [enter] the report will begin to print. Please wait while it prints and DO NOT pull / rip the receipt paper until the printing is finished. You can interrupt the printing by pressing the [feed] key.

6. After printing is completed, you can press [page up] to go back to the report menu, or press [esc] to go to the last menu level. Press [esc] twice to go back to the X reports main menu.

VIEWING X REPORTS

In addition to printing reports in X mode, you can also view sales totals directly on the clerk display. This is helpful if you want to check a specific total(Cash-in-Drawer for example) without printing a report. This function is only available in X mode and will not reset any totals after being accessed.

The following reports can be viewed in X-mode (in either daily or periodic format):

1. **Net Sales** – Shows the daily or periodic net sales total
2. **Cash In-Drawer** – Shows the daily or periodic cash in drawer total
3. **Cash Total** – Shows the daily or periodic cash sales total
4. **Check Total** – Shows the daily or periodic check sales total
5. **Credit Total** – Shows the daily or periodic credit sales total
6. **Charge Total** – Shows the daily or periodic charge sales total
7. **RA Total** – Shows the daily or periodic Received on Account total
8. **PO Total** – Shows the daily or periodic Paid Out total
9. **N/S Total** – Shows the daily or periodic No Sale total and quantity

X → 3) On-Screen → Desired report

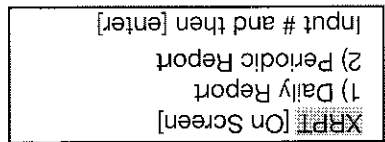

1. Turn the key to the "X" position.

2. If an X passcode has been programmed, TYPE the (PASSCODE #), then PRESS [enter], or if you did not

program a X passcode, go to Step 3.

3. Use the numeric keys to TYPE 3 and confirm with [enter]. This will bring you to the X-Report (On-Screen) menu. Choose the type of report total you would like to see, either Daily or Periodic using the numeric keys. Confirm with [enter].

5. TYPE the number of the report you want to view and press [enter]. For example, if you would like to view the cash in-drawer total, press 2 and then [enter]. You can scroll through the available report options by using the page up and page down keys.

6. After pressing [enter] the total will display. After viewing, you can press [page up] to go back to the report menu, or press [esc] to go to the last menu level. Press [esc] twice to go back to the X reports main menu.

3.3 PRINTING AND CLEARING Z REPORTS

There are two types of readings that can be taken in the "Z" position: a "Daily (Z1)" reading and a "Periodic (Z2)" reading. Note: To prevent accidental printing of the "Z" reading, a Manager Password can be set. Once the password is set, an "Z" report will not print in the "Z" position until the password is typed.

• **"DAILY(Z1)" READING** - Commonly known as an "end-of-day/daily-closeout" reading; prints transaction data and resets all transaction totals to zero except the Running Grand Total. The machine will, however, still accumulate totals in memory until a "Z2" reading is taken.

• **"PERIODIC(Z2)" READING** - Commonly known as a "weekly" or "monthly" reading; prints transaction totals either on a weekly or monthly basis (not both) and resets all transaction totals to zero except the Running Grand Total.

Most of the reports available in "Z" mode are mirrored in "X" mode, however "Z" mode is the only mode that allows you to clear reports without printing.

Z MANAGEMENT REPORTS AVAILABLE FOR PRINTING

There are a total of nine different kinds of reports available in Z mode:

- **FULL SALES REPORT** - Includes totals of departments, tax, net sales, voids, returns, coupons, refunds, minus percentage, plus percentage, receipts-on-account, no-sale activity, paid out, cash, charge, and the running grand total.

1. Turn the key to the "Z" position.
2. If an Z passcode has been programmed, TYPE the (PASSCODE #), then PRESS [enter], or if you did not program a Z passcode, go to Step 3.
3. Using the numeric keys, TYPE 1 and press [enter] to enter daily X-reports mode.
4. TYPE 6 and press [enter] to bring up the Cash Declaration report menu.
5. Using the on-screen prompts as a guide, enter the total cash amount to declare using the numeric keys. For example, if you simply wish to record a cash-in-drawer total of \$300.56, enter 30056 and press [enter]. If you would like to declare each bill / coin type in the drawer then enter the first quantity now,, press the [qty/time] key and then the bill/coin value. For example, to claim 10 x \$20 bills, enter 10 [qty/time] 2000 and [enter].
6. If you were only entering a total amount, press [enter] again to print the report. The value you entered will print first, and then the remainder of the daily report. If the calculated cash in drawer is less than or greater than the

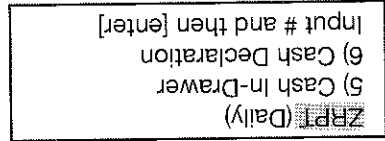

Z → 1) Daily → 6) Cash Declaration

CAUTION: The Cash Declaration feature will not allow any corrections of miscalculated or incorrect entries of the cash declared. Therefore, please double check and verify all money before getting started.

In addition to a normal daily sales report, you can also run what is called a cash declaration report. This report allows you to declare the amount of cash, as well as the types of bills in the cash drawer before running your daily report. This is useful to keep better track of your cash received. Be sure to run this report in place of the daily sales report, as once the cash declaration report is printed, it will clear the daily sales totals.

PRINTING A CASH DECLARATION REPORT

1. Turn the key to the "Z" position.
2. If an Z passcode has been programmed, TYPE the (PASSCODE #), then PRESS [enter], or if you did not program a Z passcode, go to Step 3.
3. Use the numeric keys to select the type of report you would like to print (Daily or Periodic) and confirm with [enter].
4. TYPE the number of the report you want to print and press [enter]. For example, if you would like to print the daily full sales report, press 1 and then [enter]. You can scroll through the available report options by using the page up and page down keys.
5. After pressing [enter] the report will begin to print. Please wait while it prints and DO NOT pull / rip the receipt paper until the printing is finished. You can interrupt the printing by pressing the [feed] key.
6. After printing is completed, you can press [page up] to go back to the report menu, or press [esc] to go to the last menu level. Press [esc] twice to go back to the Z reports main menu.

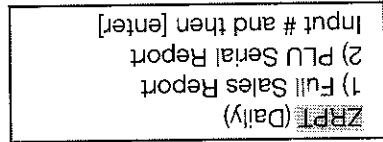

Z → 1) Daily or 2) Periodic → Desired report

PRINTING Z REPORTS

- **PLU SALES REPORT** - Lists the total quantity and cost of each PLU number rung up.
- **HOURLY REPORT** - Provides total sales amounts rung up each hour.
- **CLEERK SALES REPORT** - Exclusively prints total sales amounts of each Clerk Number operated, tax total or no-sale counter.
- **CASH-IN-DRAWER REPORT** - simply tells you how much cash is in the drawer at the time of the report.
- **CASH DECLARATION** - Allows you to declare the actual amount of cash in the drawer and automatically generates the "Z1" (End-of-Day/Daily-Close-out) Report.
- **TRAINING REPORT** - Prints the total sales rung up in training mode. This report is only available in X mode.

7. If you are entering individual bill totals, continue doing so now, until you have declared all the cash in the drawer. declared value, it will be shown on the top of the report.
8. After printing is completed, you can press [esc] to go to the last menu level. Press [esc] twice to go back to the Z reports main menu.

A sample Cash declaration report is shown below :

***** Z1 *****		
CASH DECLARATION	3X	5.00
	7X	1.00
	4X	0.25

TOTAL		23.00
CAID		23.00
		+0.00

FULL REPORT	1Q	23.00
DEPT02		

REGULAR "Z1" TAPE FOLLOWS		

Note: The zero dollar amount indicates that the Declared Amount and the Calculated Amount both balance. A negative dollar amount would indicate less money is in the drawer than what was collected. Any amount greater than \$0.00 would indicate more money is in the drawer than what was collected.

CLEARING Z REPORTS

If you wish to reset your Z totals, without printing a report, you can simply clear either the daily, or periodic full sales report directly in Z mode. To do so, you must use the report clear passcode. This passcode is selected at the factory and cannot be changed. The report clear passcode is 3610. Please write this passcode down in a safe place for future reference. If you accidentally lose this passcode, please contact Royal customer service.

Z → 1) Daily or 2) Periodic → Desired report

ZRPT (Rpt. Clear)	1) Daily
	2) Periodic
Input # and then [enter]	

1. Turn the key to the "Z" position.
2. If an Z passcode has been programmed, TYPE the (PASSCODE #), then PRESS [enter] , or if you did not program a Z passcode, go to Step 3.
3. Use the numeric keys to TYPE 3, then press [enter] to reach the report clear menu.
4. TYPE the number of the report you want to clear and press [enter] . For example, if you would like to clear the daily report, press 1 and then [enter] .
5. After pressing [enter] you will be prompted to enter the clear passcode. Enter this now and press [enter] .
6. Once the report is cleared, you will see a confirmation on the clerk screen. Press [esc] to go back to the report clear menu, and again to go to the Z report main menu.

REPORT EXAMPLE

Daily Sales Full report:

***** Z 1 *****		FULL REPORT	
DEPT0001	6Q	590.00	Sales quantity
DEPT0002	5Q	1,000.00	Sales amount
DEPT0003	6Q	1,800.00	
DEPT0004	6Q	2,400.00	
DEPT TTL	23Q	5,790.00	
NOTXBL		5,770.00	
GROSS		5,915.00	
NET TTL		5,770.00	
VOID	1N	100.00	Number of voids
-%N	1N	5.00	VOID dollar value
COUPON N	1N	5.00	
COUPON G	1N	5.00	
+	1N	30.00	
-%G	1N	15.00	
Discharge rate for Single item		15.00	
Discharge for Subtotal and Total		1,970.00	
CASH	10N	1,970.00	Cash sale quantity
CASH	1N	5.00	Cash sale amount
CHECK	1N	700.00	
CHARGE	1N	700.00	
CHARGE	1N	700.00	
CREDIT	2N	1,700.00	
R/A CA	1N	25.00	
P/O CA	1N	1,800.00	
CAID	1N	-805.00	
CKID	1N	700.00	
CKID	1N	700.00	
CPID	1N	2,700.00	
RPRT CNT	Z1 3		Z1 counter
CLEBK 01	15N		
NET TL		5,070.00	
VOID	1N	100.00	
		15:38	
		2008-04-24	
		0001 CLBRK 01 0018	

CHAPTER 3: RUNNING, CLEARING AND SAVING REPORTS

The following illustrates how totals are calculated for the Management Reports.

NET SALES TOTAL - Represents the true sales for the day. The net sales total includes department total (TL) and tax total (TX).

NOTE: Minus percentage discount (-%), voids (VD) and returns/refunds (RT) are all deducted from the department totals and the plus percentage (+%) is added to the department totals.

GROSS SALES - Represents the total of all sales registered. The Gross Sales includes net sales total (NS), coupon discount (-), minus percentage discount (-%), return/refund (RT), and void (VD).

SYSTEM BALANCE:

DEPARTMENT 1	(+)	49.29
DEPARTMENT 2	(+)	118.17
DEPARTMENT 3	(+)	57.46
DEPARTMENT 4	(+)	15.77
DEPARTMENT TOTAL	(=)	240.69

DEPARTMENT TOTAL	(+)	240.69
TAX TOTAL	(+)	9.55
NET SALES TOTAL	(=)	250.24

NET SALES TOTAL	(+)	250.24
COUPON DISCOUNT	(-)	5.00
MINUS PERCENTAGE	(-)	.14
RETURN/REFUND	(+)	10.00
VOID	(+)	12.00
GROSS SALES	(=)	267.10

MEDIA BALANCE:

NET SALES TOTAL	(+)	250.24
CHECK TOTAL	(-)	44.01
CHARGE TOTAL	(-)	74.19
RECEIVED-ON-ACCOUNT (Cash)	(+)	100.00
PAID OUT (Cash)	(-)	5.00
CASH-IN-DRAWER	(=)	227.04

3.4 SAVING Z REPORTS TO A USB DRIVE

In addition to printing and clearing reports in Z mode, you can also save some reports directly to a USB based drive or device. This is useful allow you to sync with the included RegisterLink program, which physically connecting to a PC. This data can then be imported to QuickBooks via the RegisterLink menu. Please read your RegisterLink manual for further instructions on how to do this.

Before entering USB communication mode, be sure to insert the USB device into the USB port located on the left side of the cash register. You may need to remove the barcode scanner if you are using it. Please note the USB device can only be inserted in one direction, do not force the device into the port or you may damage the cash register.

The following reports can be saved to a USB drive in Z mode:

1. **Daily Department / Clerk Report** - saves the daily department and clerk sales data
2. **Daily PLU Report** - saves the daily PLU sales data
3. **Periodic Department / Clerk Report** - saves the periodic department and clerk sales data
4. **Periodic PLU Report** - saves the periodic PLU sales data

1. Turn the key to the "Z" position.
2. If an Z passcode has been programmed, TYPE the (PASSCODE #), then PRESS [enter], or if you did not program a Z passcode, go to Step 3.
3. Use the number keys to select 4) USB COMM and press [enter].
4. After entering the main USB communication menu, TYPE 2 and then [enter] to go to the Download to USB option.
5. TYPE the number of the report you want to save and press [enter]. For example, if you would like to save the daily PLU report, press 4 and then [enter]. You can scroll through the available report options by using the page up and page down keys.
6. After pressing [enter] the report will begin to save. Please wait while it saves and DO NOT remove power from the machine or remove the USB device until the download is finished.
7. Once the download is complete, press [esc] to go to the last menu level. Press [esc] twice to go back to the Z reports main menu.

ZRPT(USB COMM)
1: Upload from USB
2: Download to USB
Input # then [enter]

Z → 4) USB COMM → 2) Download to USB → desired report

5. Daily and Periodic Department / Clerk Report – saves both the daily and periodic department and clerk sales data.
6. Daily and Periodic PLU Report – saves both the daily and periodic PLU sales data.

The optional Training Mode is designed to help you become better acquainted with the register mode and offers an ideal place for "beginners" and new employees to practice transaction examples. Once the Training Mode is activated, there is no access to any operations in the "PRG", "X", or "Z" modes. Also note, the transaction numbers do not count up in the Register Mode until you exit the Training Mode. The Training Mode can be activated at any time from the X mode options window.

To enter training mode, you must switch to the X position, and enter the training mode passcode. By default, the training passcode is 999. You can change this passcode at any time by using the programming menu. See To Program the Training Passcode on page 22 for more information.

Once training mode is active, you are free to ring up transactions without effecting the internal cash register totals. When training mode is active the words **TrainM**d will appear on the display in place of the clerk name, and **TRAINING** will appear on the top of all receipts. Example screenshots are shown here :

TRAINING	DEPT0001	10.00	CASH	10.00
ITEM CT	1			
CHANGE:	10.00			
CASH TEND:	10.00			
PAYMENT:	10.00			
TrainM	0.00			

ENTERING / EXITING TRAINING MODE

Training mode can only be entered and exiting from the X position.

XPRT	1:Daily	2:Periodical	3:On-Screen	4:Training
Input # then [enter]				

X → 4) Training

1. Turn the key to the "X" position.
2. If an X passcode has been programmed, TYPE the (PASSCODE #), then PRESS [enter], or if you did not program a X passcode, go to Step 3.
3. Use the numeric keys to select 4) Training and confirm with [enter].
4. You will be prompted to enter the training passcode. Enter it now and confirm with [enter].
5. After pressing [enter] the screen will update to reflect that you are in training mode. Switch the cash register to REG mode to run sample transactions.
6. To exit training mode, follow steps 1-5 with training mode active.

CHAPTER 5: TRANSACTION EXAMPLES

The following section of the user's manual will go over using many of the different functions of the cash register while in a sales environment. Before practicing any of these examples, do the following :

1. Confirm the programming and initial set-up are complete
2. Be sure there is paper in the cash register and it is installed correctly
3. Turn the control lock to the "REG" position to enter sales registration mode

IMPORTANT: It is not necessary to press the Decimal Point when ringing up a price. If Clerk Numbers are programmed, be sure to **ENTER** the (CLERK #), then **PRESS** the [CLERK] key before ringing up a sale.

The following is a screenshot of what you will see during a sales transaction. Each of the parts of the screen are labeled so you can get familiar with the different text. These will change depending on the type of transaction you may be entering.

1	CLERK01	0.00
3	DEPT0001	[12] X
5	Price: 1.00	12.00
7	TOTL:	12.00

- 1: Active Clerk will be shown here
 - 3: Dept./PLU description
 - 5: Current item dollar value
 - 7: Dept./PLU unit price
- 2: Input value will be shown here
 4: Item Quantity
 6: Transaction total

EXAMPLE 1: CASH SALE WITH CHANGE TENDERED

Ring in PLU12 for a total sale of \$10.00. Enter a payment of \$20.00 with change calculated.

1X	@10.00	10.00
PLU0012	ITEM CT	1
TOTAL	10.00	
CASH TD	20.00	
CHANGE	9.00	

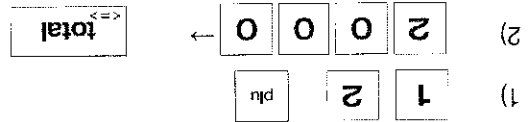

EXAMPLE 2: REGISTERING A SALE USING A DEPARTMENT KEY

Ring in \$12.00 in Department 1. Finalize the sale as a cash transaction.

DEPT0001	ITEM CT	12.00
CASH	12.00	

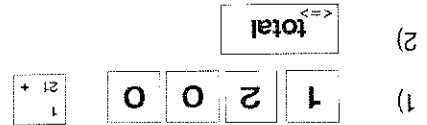

EXAMPLE 3: CHECK SALE

Ring in PLU1500 for \$34.00 and finalize the sale with the [check] key.

PLU1500	ITEM CT	34.00
CHECK	34.00	



EXAMPLE 4: CHARGE SALE

Ring in PLU1700 for \$20.00 and finalize the sale with the [charge] key.

PLU1700	ITEM CT	20.00
CHARGE	20.00	



CHAPTER 5: TRANSACTION EXAMPLES

EXAMPLE 5: SPLIT TENDERING SALE

Ring in PLU1300 for \$96.30 and pay \$50.00 by check and \$50.00 by cash.

1) [1] [3] [0] [0] → [plu] → [5] [0] [0] [0] → [check]

2) [5] [0] [0] [0] → [total]

PLU 1300	96.30
ITEM CT	1
TOTAL	96.30
CHECK TD	50.00
CASH TD	50.00
CHANGE	3.70

NOTE: If you are processing a split tender transaction, always ring in any credit / charge amount **LAST** to avoid an error.

EXAMPLE 6: NO SALE FUNCTION

Open the cash drawer without entering a sales transaction. This is used sometimes to make change for a customer.

1) [#] [ns]

[NOSALE]

NOTE: Before pressing the [ns] key, you can enter a value using the numeric keys. This value will be totaled and will print when you do a No Sale report.

EXAMPLE 7: RINGING IN MULTIPLE ITEMS

Ring in PLU14(Price of \$1.0), PLU16(Price of \$3.00), and PLU126(Price of \$10.00) and finalize the transaction as a cash sale.

1) [1] [4] → [plu]

2) [6] → [plu]

3) [1] [2] [6] → [plu]

4) [total]

CLEERK01	0.00
PAYMENT:	14.00
CASH TEND:	14.00
CHANGE:	0.00

NOTE: You can also use this procedure for ringing in Departments by substituting the department keys for the PLU keys in the example above.

EXAMPLE 8: USING THE QTY KEY

Ring in 2 x PLU126(Price of \$10.00) and finalize the sale as a cash transaction

1) [2] → [qty/time] → [1] [2] [6] → [plu]

2) [total]

CLEERK01	0.00
PLU 0126	[2] X
Price:	10.00
TOTL:	20.00

CLEERK01	0.00
PAYMENT:	20.00
CASH TEND:	20.00
CHANGE:	0.00

NOTE: You can use the same procedure for a department entry by substituting the department key for the PLU key in the example above.

NOTE: A received on account sale must be entered separately from other sales.

1) → → → →

CLERK01	0.00	R/A	25.00
AMNT:	25.00	R/A CA	25.00
TOTAL	25.00		

Process cash received on account amount of \$25.00.
EXAMPLE 12: RECEIVED ON-ACCOUNT SALE

NOTE: You can add any or all tax rates(1-4) to an item by pressing the tax rate number and tax force key for each tax you want to apply. For example, if you want to add taxes 1 and 3 to an item, press 1 [tax force], 3 [tax force], and then ring in your sales entry.

1) → → → → →

DEPT0002 T1	200.00	ITEM CT	1
TAX-1	10.00	TAXTOTAL	10.00
TAX	10.00	CASH	210.00

Assume department 2 is set as non-taxable. Ring in \$200.00 in department 2, charging tax-1 to this department and finalize the transaction as a cash transaction.

EXAMPLE 11: USING THE TAX FORCE FUNCTION

NOTE: To exempt tax, you must do so on an item by item basis. You cannot exempt tax on an entire transaction.

B. → → →

DEPT0001	100.00	ITEM CT	1
TAX	5.00	TAXTOTAL	5.00
CASH	105.00		

A. → →

DEPT0001 T1	100.00	ITEM CT	1
TAX-1	5.00	TAXTOTAL	5.00
TAX	5.00	CASH	105.00

Assume department 1 is set as taxable (tax-1). Ring in \$100.00 in department 1 and finalize the transaction as a cash transaction(example A). Repeat the transaction but exempt the tax(example B).

EXAMPLE 10: EXEMPTING TAX ON AN ITEM

NOTE: You can use the same procedure with a department entry by substituting the department key for the PLU key in the example above.

1) → → →

CLERK01	0.00	PLU 0006	[3] X
Price:	3.00	TOTL:	9.00

CLERK01	0.00	PLU 0006	[1] X
Price:	3.00	TOTL:	3.00

Ring in PLU6 (Price of \$3.00) three times and finalize the sale as a cash transaction.
EXAMPLE 9: REPEATING A PLU ENTRY

EXAMPLE 13: PAID-OUT SALE
Process \$12.00 cash taken out of the cash drawer.

1) → →

2) →

P/O	12.00
P/O CA	12.00

CLERK01	0.00
P/O	12.00
AMNT:12.00	12.00
TOTAL	12.00

EXAMPLE 14: RETURN MERCHANDISE SALE
Ring a return merchandise sale of 1 x PLU14 and 2 x PLU126 and finalize the sale as a cash sale.

1) → → →

2) → → → →

3) →

RETURN	20.00
PLU0014	20.00
-2X @10.00	20.00
PLU0126	20.00
ITEM CT	-3
CASH	-40.00

EXAMPLE 15: VOIDING A SALES ENTRY
Ring in a PLU14 and PLU126 and then void the PLU14 entry. Finalize the sale as a cash sale.

1) → → → → →

2) → → →

3) →

PLU0014	20.00
PLU0126	10.00
SUB-TTL	30.00
-VOID-	10.00
PLU0014	20.00
ITEM CT	1
CASH	10.00

EXAMPLE 16: USING THE ERROR-CORRECT(EC) KEY
Ring in PLU126, correct the error and then ring in PLU14. Finalize the sale as a cash sale.

1) → →

2) →

3) → →

4) →

PLU0126	10.00
-VOID-	10.00
PLU0126	10.00
PLU0014	20.00
ITEM CT	1
CASH	20.00

EXAMPLE 17: CANCELLING A TRANSACTION
Ring in \$1.23 in department 2 and then cancel the transaction.

1) → → →

CLERK01	0.00
DEPT0002	[1] X
Price: 1.23	1.23
TOTAL	1.23

CLERK01	0.00
TRANSACTION CANCELLED	0.00

EXAMPLE 18: APPLYING A COUPON DISCOUNT TO AN ITEM ENTRY
 Ring in \$100.00 in Department 1 then \$300.00 in Department 2 with a \$78.00 coupon applied. Finalize the sale as a cash sale.

1) [1][0][0][0][0] → [1] → [21+] → [3][0][0][0][0] → [2] → [2] → [total]

2) [7][8][0][0] → [coupon]

3) [total]

CLEARK01	0.00
COUPON N	-78.00
TOTAL	322.00

DEPT0001	100.00
DEPT0002	300.00
COUPON N	78.00
ITEM CT	2
CASH	322.00

EXAMPLE 19: APPLYING A COUPON DISCOUNT TO AN ENTIRE SALE
 Ring in 4 x PLU14, \$30.00 in Department 2 and then apply a \$2.00 coupon. Finalize the sale as a cash sale.

1) [4] → [qty/time] → [1][4] → [plu] → [3][0][0][0] → [2] → [2] → [total]

2) [2] → [#/s/] → [2]

3) [2][0][0] → [coupon]

4) [total]

CLEARK01	0.00
COUPON G	-2.00
TOTAL	108.00

@20.00	4X
PLU0014	80.00
DEPT0002	30.00
SUB-TTL	110.00
COUPON G	2.00
(DPBL	110.00)
ITEM CT	5
CASH	108.00

EXAMPLE 20: APPLYING A MINUS PERCENTAGE(-%) DISCOUNT TO AN ITEM
 Ring in PLU14 and then apply a 20% discount. Finalize the sale as a cash sale.

1) [1][4] → [plu] → [2][0] → [%] → [total]

2) [total]

The receipt shows:

CLEARK01	0.00
Rate: 20.00%N	-4.00
TOTAL	16.00

PLU 0014	20.00
-%N 20%	4.00
ITEM CT	1
CASH	16.00

NOTE: If you have preset the minus percentage(-%) rate programmed, you can simply press the [%] key to apply it.

EXAMPLE 21: APPLYING A MINUS PERCENTAGE(-%) DISCOUNT TO A TOTAL
 Ring in 10 x PLU14, 2 x PLU126 and then apply a 10% minus percentage to the transaction total. Finalize the sale as a cash sale.

1) [1][0] → [qty/time] → [1][4] → [plu] → [2] → [2] → [qty/time] → [1][2][6] → [plu]

2) [total]

NOTE: If you have preset the minus percentage (-%) rate programmed, you can simply press the [-%] key to apply it.

EXAMPLE 22: APPLYING A PLUS PERCENTAGE(+%) RATE TO AN ITEM

Ring in PLU14 and then apply a preset 10% add-on(+%). Finalize the sale as a cash sale.

1)

CLEBK01	0.00
+%N	
Rate: 10.00%N	2.00
TOTAL	22.00

The receipt shows:

PLU 0014	20.00
+%N 10%	2.00
ITEM CT	1
CASH	22.00

2)

NOTE: If you want to manually enter a plus percentage (+%) rate, you can simply enter it before pressing the [+%].

EXAMPLE 23: APPLYING A PLUS PERCENTAGE (+%) RATE TO A TOTAL

Ring in PLU14, PLU126 and then apply a 10% add-on(+%). Finalize the sale as a cash sale.

1)

2)

3)

CLEBK01	0.00
SUBTTL:	30.00
TOTAL	30.00

4)

CLEBK01	0.00
+%G	
Rate: 10.00%G	4.00
TOTAL	34.00

5)

The receipt shows:

1X	@20.00
PLU 0014	20.00
1X	@10.00
PLU 0126	10.00
SUB-TTL	30.00
+%G 10%	4.00
(DPBL	30.00)
ITEM CT	2
CASH	34.00

EXAMPLE 24: RINGING IN A PRODUCT WITH A BARCODE
 Ring in PLU 1, by manually entering its barcode of 6927073400541. Finalize the sale as a cash sale.

1) 6 9 2 7 0 7 3 4 0 0 5 4 1 → plū

2) total

CLEERK01	0
PLU 0001	[1] X
Price: 10	10.00
TOTL:	10.00

CLEERK01	0
PAYMENT:	10.00
CASH TEND:	10.00
CHANGE:	0.00

NOTE: If you are using the barcode scanner, you can simply scan the barcode during step one. Also, to manually enter barcodes, you must activate the Config. Option (flag0706).

EXAMPLE 25: RINGING IN A DEPARTMENT USING THE DEPARTMENT SHIFT KEY

Ring in \$1.23 in Department 21. Finalize the sale as a cash transaction.

1) dept shift → 1 2 3

CLEERK01	1.23
DEPT0021	[1] X
Price: 1.23	1.23
TOTL: 1.23	

CLEERK01	0.00
DEPT0021	[1] X
Price: 1.23	1.23
TOTL: 1.23	

3) total

EXAMPLE 26: RINGING IN A DEPARTMENT # OVER 40

Ring in \$5.13 in Department 200. Finalize the sale as a cash transaction.

1) 5 1 3 → dept → 2 0 0

CLEERK01	0.00
DEPT0200	[1] X
Price: 5.13	5.13
TOTAL	5.13

DEPT0200	5.13
ITEM CT	1
CASH	5.13

EXAMPLE 27: TEMPORARILY ADJUSTING A PLU PRICE

Ring in PLU 12 as \$40.00. Finalize the sale as a cash sale.

1) 4 0 0 0 → plū alt → 1 2 → total

CLEERK01	0.00
PLU0012	[1] X
Price: 40.00	40.00
TOTAL	40.00

PLU0012	40.00
ITEM CT	1
CASH	40.00

EXAMPLE 28: CHECKING A PLU PRICE

Check the price of PLU12(\$40.00).

1) 00
 2) 1 2 → plū

CLEERK01	0.00
PLU 0012	#0012
Price	40.00

NOTE: You can also press [00] and then scan a barcode to check the PLU price.

CHAPTER 6: OTHER CASH REGISTER FUNCTIONS

In addition to entering sales, printing reports and so on, your 9500ML cash register has many other available. This chap- ter will deal with though functions.

6.1 TURNING THE RECEIPT PRINTER ON / OFF

To save paper you can turn On / Off the receipt printer of your 9500ML cash register. This is useful if you do not normally give customer receipts. Even with the receipt print off, you can always print a duplicate receipt (if the function is allowed). While in REG mode, you can toggle the receipt printer on and off using the [receipt on/off] key. This procedure will only work if it is the first key pressed. Press [clear] beforehand to make sure this is the case.



When the receipt printer is off, the following picture indicator will appear on the top line of the clerk display

6.2 PRINTING A DUPLICATE RECEIPT

If necessary and active(check flag 0407) you can print a duplicate receipt copy immediately after ending a sales transac- tion. The duplicate receipt can only be printed before starting another transaction. The duplicate receipt can be printed even if the receipt printer is turned OFF. This allows you to print a "receipt-on-demand". To verify that the duplicate receipt is printed, a *2nd RECEIPT* message will print on it. If you begin to ring in sales before printing the second receipt, you lose the ability to print the duplicate receipt. The example below walks you through printing a duplicate receipt.

EXAMPLE: PRINTING A DUPLICATE RECEIPT

Ring in \$4.56 in Department 1, \$7.89 in Department 2 and finalize the sale as a cash sale. Print a duplicate receipt after the transaction.

DEPT0001	4.56
DEPT0002	7.89
ITEM CT	2
CASH	12.45

Original receipt:

DEPT01	4.56
DEPT02	7.89
ITEM CT	2
CASH	12.45
* 2nd RECEIPT*	

A Second Receipt:



6.3 PRINTING A COMMERCIAL RECEIPT

In addition to the journal tape roll, you can also tell the cash register to print a commercial receipt for every original re- ceipt generated. This commercial receipt will print the names and quantities of all the items entered during the previous transaction. To turn on the commercial receipt printing, see flag 0705.

NOTE: The receipt printer must be turned ON for the commercial receipt to print.

EXAMPLE : COMMERCIAL RECEIPT PRINTOUT

Ring in Department 1 (preset to \$110.00) twice, Department 2 (preset to \$150.00) once, PLU1 and PLU2 once. Finalize the sale as a cash sale, and print a commercial receipt.

DEPT0001	110.00
DEPT0001	110.00
DEPT0002	150.00
PLU0001	100.00
PLU0002	200.00
ITEM CT	5
CASH	670.00

Normal receipt

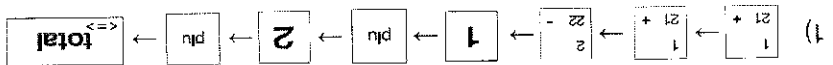

DEPT01	2X
DEPT02	1X
PLU0001	1X
PLU0002	1X

Sample of Commercial Receipt

6.4 CHECKING THE TIME/DATE IN REG MODE

While you are operating the cash register, and ringing sales transactions you can display the current time and date. To do so, you must finish the current transaction you are running. The time and date will display on both the clerk and customer displays. To display the time and date, simply press the [qty/time] key between transactions. Below is an example:

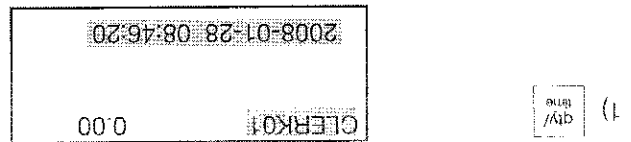

6.5 USING CALCULATOR MODE

In addition to the calculations you can accomplish using the internal calculator on the 9500ML, you can also use it as a manual calculator between sales transactions. The calculator function is only available in the REG position. The calculator mode is active, the clerk display will change and show CalcMd. The following keys are used in calculator mode:

- [PO(cal)] -- Used to enter and exit calculator mode
- [1/21 +] -- Used to add values (+)
- [2/22 -] -- Used to subtract values(-)
- [3/23 x] --Used to multiply values(x)
- [4/24 ÷] --Used to divide values (÷)
- [RA(mr)] --Used to recall a calculation in sales registration mode
- [amount tend =] --Used to process a calculation.

To enter calculator mode, press [PO(cal)] in register mode. Use the numeric keys to enter any values and the department keys 1-4 to process any calculations. To exit calculator more press [PO(cal)]. To recall your calculation, press the [RA(mr)] key. The value will display on the screen and you can apply it to a department as needed.

NOTE: Calculator mode is only available between transactions in REG position.

EXAMPLE USING THE CALCULATOR FUNCTION

Complete the following calculation and recall it to begin a sales transaction 1000 + 2000 - 300 = ??

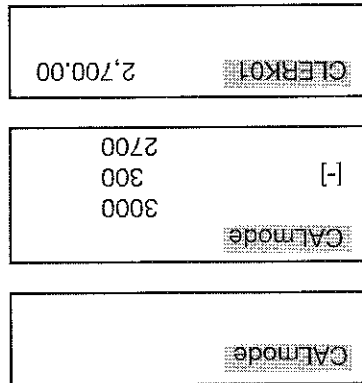
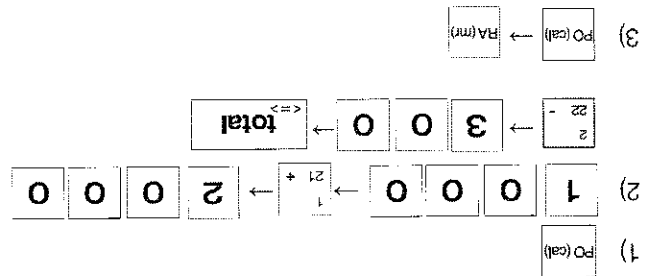

6.6 USING THE FOREIGN CURRENCY(FC) FUNCTION

Your 9500ML cash register can accept foreign currencies and automatically apply the conversion rate during a transaction. This speeds up sales if you are selling in an area with multiple currencies. To use the FC function, you need to program a key as a FC key. See section 2.13 Adjusting the keyboard on pages 42-43 for more instructions. Once you have a key set as FC, you have to set the conversion rate(%) for the calculation to be completed properly. Please see section 2.15 Programming the Foreign Currency (FC) Key on pages 46-47 for help in doing this. After you have setup both an FC key, and an FC rate, you can process Foreign Currency transactions. The following examples will help you utilize this function.

EXAMPLE 1: ACCEPTING AN FC PAYMENT

Ring in \$10.00 in Department 1 and process the sale using FC 1(preset to .5 to 1).

1) [1] [0] [0] [0] [1] + [21] → [FC1] The receipt shows:

DEPT0001	10.00
ITEM CT	1
TOTAL	10.00
(TTL FCRATE 5.00)	
FCRATE1	5.00

CLEBK01	0.00
SUBT:10.00	FC:5.00
QUANTITY:	1
TOTL:	10.00

EXAMPLE 2: ACCEPTING AN FC PAYMENT AND TENDERING CHANGE(LOCAL)

Ring in \$10.00 in Department 1 and process the sale with \$50.00 using FC 1 (preset to .5 to 1). Change calculation is shown in local currency.

1) [1] [0] [0] [0] [1] + [21] → [FC1] [5] [0] [0] [0] [0] The receipt shows:

DEPT0001	10.00
ITEM CT	1
TOTAL	10.00
(TTL FCRATE 5.00)	
FCRATE1	50.00
(CASH TD 100.00)	
CASH	90.00

CLEBK01	0.00
PAYMENT:	10.00
CASH TEND:	100.00
CHANGE:	90.00

EXAMPLE 3: ACCEPTING AN FC PAYMENT AND TENDERING CHANGE(FC)

Ring in \$10.00 in Department 1 and process the sale with \$50.00 using FC 1(preset to .5 to 1). Change calculation is shown in FC currency.

1) [1] [0] [0] [0] [1] + [21] → [FC1] [5] [0] [0] [0] [0] The receipt shows:

DEPT0001	10.00
ITEM CT	1
TOTAL	10.00
(TTL FCRATE 5.00)	
FCRATE1	50.00
(CASH TD 100.00)	
FC_CG	45.00

CLEBK01	0.00
PAYMENT:	10.00
CASH TEND:	100.00
CHANGE:	90.00

If you have any questions regarding the software, please see the RegisterLink® manual included on the CD. For further assistance, call the Royal support line at 1-800-272-6229 (US customers).

Your cash register can communicate with your PC via the USB port and the enclosed USB cable. Using the enclosed CD containing RegisterLink® PC-based software allows the register to communicate with your PC. It also contains software filter to download your end-of-day totals into QuickBooks® accounting software packages.

6.8 SAVING / LOADING DATA FROM A PC

1. Turn the key to the "Z" position.
2. If a Z passcode has been programmed, TYPE the (PASSCODE #), then PRESS [enter], or if you did not program a Z passcode, go to Step 3.
3. Use the number keys to select 4) USB COMM and press [enter].
4. After entering the main USB communication menu, TYPE either 1 or 2 and then [enter] to go to the respective option.
5. TYPE the number of the data you want to save or load and press [enter]. For example, if you would like to save the PLU data, press 2 and then [enter]. You can scroll through the available report options by using the page up and page down keys.
6. After pressing [enter] the information will begin to save or load. Please wait while it saves and DO NOT remove power from the machine or remove the USB device until the download is finished. It may take a few minutes to upload / download the data, so please be patient.
7. Once the download is complete, press [esc] to go to the last menu level. Press [esc] twice to go back to the Z reports main menu.

ZRPT(USB COMM)
1: Upload from USB
2: Download to USB
Input # then [enter]

Z → 4) USB COMM → 1) Upload from USB or 2) Download to USB → desired data

NOTE: Uploading / Downloading data from a USB drive can ONLY be accomplished in Z mode.

- Programming Data(Basic) – This is the main setup information for your 9500ML cash register. This data includes department, clerk, config, Options, keyboard layout, taxes, transaction words, discount settings, system options, FC settings, and the header / footer messages.
- PLU Data(Programming) – This data includes the PLU names, prices, linking departments and any barcodes programmed.

In addition to saving and loading your cash register programming data from a PC (using the RegisterLink software that is included), you can also do this directly using a USB drive (sold separately). This is convenient if you have multiple locations, or if your cash register is not located close to your PC. A compatible USB drive can be purchased directly from any electronics retailer. The following information can be saved to or loaded from a USB drive:

6.7 SAVING / LOADING PROGRAMMING DATA USING A USB DRIVE

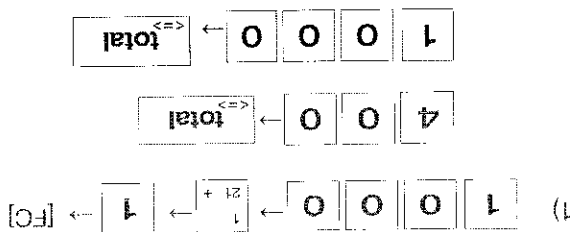

DEPT0001	10.00
ITEM CT	1
TOTAL	10.00
(TTL FC RATE	5.00)
FC RATE1	4.00
(CASH TD	8.00)
CASH TD	10.00

The receipt shows:

EXAMPLE 3: ACCEPTING AN FC PAYMENT AND TENDERING CHANGE(FC)
 Ring in \$10.00 in Department 1 and process the sale giving \$4.00 in FC 1(preset to .5 to 1) and \$10.00 in local currency. Change calculation is shown in local currency.

CHAPTER 6: OTHER CASH REGISTER FUNCTIONS

NOTE: You must have RegisterLink version 1.0P or later to connect with your 9500ML cash register.

CONNECTING TO A PC

Connecting your cash register to a PC is easy. Please follow the following steps to do so:

1. Unpack and install the RegisterLink software CD
2. Connect your cash register to your PC using the included cable
3. Switch the control lock key to the "OFF" position
4. Open and run the RegisterLink software and use it to download / upload any data to/from the cash register

CHAPTER 7: TROUBLESHOOTING

The following chapter helps you resolve any errors you may experience while operating your 9500ML cash register. Most errors are described on the clerk screen and you are prompted with the corrective action to take. This section generally describes other possible issues and what to do. Select and follow the procedure which best describes what is happening.

7.1 GENERAL ERROR MESSAGES

If you are operating the cash register and you hear an error tone and see a message highlighted in bold, you may have uncovered an error. Most errors are simple function errors (wrong key was pressed), and can be resolved by pressing the [clear] key. If you experience one of these errors, read the message and act accordingly.

7.2 PAPER END OR PRINTER ERRORS

Both errors mean there is a problem with the printer.

CAUTION: Do not manually pull the receipt paper. Always use the [feed] keys to advance the paper.

1. Open the printer cover and check if you are out of paper. If so, install a new roll.
2. Check for a paper jam. If so, carefully remove any paper obstructing the printers.
3. Check and make sure the paper was aligned properly in the print and that the printer arm is snapped into place.
4. After the paper jam is successfully removed, press the [clear] key. If an error message still appears, unplug the cash register, wait 10 seconds, and plug it back in.
5. As a last resort, follow the directions for a Full System Clear.

7.3 NO RECEIPT IS PRINTING

If no receipt is printing for a sales transaction, look for the  symbol on the clerk display. If the symbol is displayed, press the [receipt on/off] key to turn it on. If the symbol does not display and the receipt doesn't print, check for a paper jam.

7.4 NOTHING IS PRINTING ON THE RECEIPT

If the cash register is not printing on the receipt, make sure you are using thermal paper. Bond paper will not work in this cash register. If needed, contact the Royal Customer Support hotline at 1-800-272-6229 for additional help.

7.5 THE CASH REGISTER DISPLAY GOES DARK

This is normal. To save power, the 9500ML clerk display will turn dark. Press any key to revive it.

7.6 IF THE CASH REGISTER DOES NOT WORK

If the cash register does not respond except with an error, make sure you are not in the middle of a transaction. Enter a price using the numeric keys, press a department key and then [amount tend total].

Afterwards continue what you were trying to do.

7.7 IF THE CASH REGISTER DOES NOT WORK AT ALL

Be sure the cash register is plugged into a working electrical outlet and no other electrical device is using the same power source. Another electrical motor on the same circuit can keep the cash register from working properly.

- If the error still persists, perform a Half System Clear procedure.

- If the Half System Clear does not work, perform a Full System Clear procedure. See that section in this chapter for more information.

- If needed, contact the Royal Customer Support hotline at 1-800-272-6229 for additional help.

7.8 OPENING THE CASH DRAWER MANUALLY OR WHEN THERE IS NO POWER

If there is no power, and you need to open the drawer, you can do so.

1. With your hands on the cash drawer, carefully tip the front of the register up. Underneath the cash register, toward the back of the unit, you will see a small lever.
2. Push the lever in the only direction it will move. The cash drawer will open.

7.9 HALF SYSTEM CLEAR

If you cannot get the cash register to respond, try a half system clear. When performing a half system clear, you will lose any current transaction memory, however your programming data will not be lost.

- Turn the control lock to the "OFF" position
- Unplug the cash register from its power source.
- Turn the control lock to the "PRG" position.
- Wait 10-30 seconds and then plug the cash register back in.
- The cash register should activate, and print HALF SYSTEM CLEAR to confirm.
- Resume normal operations.

7.10 FULL SYSTEM CLEAR

If nothing else works, you can perform a Full System Clear. CAUTION: This procedure will reset the cash register back to the factory settings. You will lose all transaction and programming data.

- Unplug the cash register from its power source.
- Turn the control lock to the "PRG" position.
- Press and hold the [clear] key and then plug the cash register back in.
- The cash register should activate, and print FULL SYSTEM CLEAR to confirm.
- Resume normal operations.

7.11 IF NOTHING HELPS

If a problem still persists, call our Customer Service Support Line toll-free at 1-800-272-6229.

CHAPTER 8: PRODUCT INFORMATION

Product Information

Specifications and Safety

Table 9 Specifications And Safety

Feature	Description
Type	Electronic cash register
Displays	Five line alphanumeric LCD clerk display One line numeric LED customer display
Printer	57mm alphanumeric thermal printer
Ink Source	Thermal printer - no ribbon or ink needed
Paper Supply	2¼ inch or 57.5 mm wide standard thermal paper (Royal Reorder # 013127)
Memory Battery Protection	Roughly 30 days after power interruption
Technology	CMOS RAM, USB port
Electrical Characteristics	115V~60HZ, 0.40A
Operating Temperature	0-40 Degrees Centigrade (32-104 Degrees Fahrenheit)
Dimensions	16"W x 16.25"D x 12"H
Weight	21-lbs. (9.5-kg)

Trademark Notice
 All trademarks, registered trademarks and service marks mentioned in this manual and with this product are for identification purposes only and are the property of their respective holders.
 Copyright © 2008 by Royal Consumer Information Products, Inc.

Proposition 65 Notice
 The following is given in accordance with California Proposition 65.
WARNING: This product contains chemicals known to the State of California to cause cancer, birth defects, or other reproductive harm.
 Wash hands after handling.

CAUTION: RISK OF EXPLOSION IF BATTERY IS REPLACED BY AN INCORRECT TYPE

- Replace only with the same type of batteries recommended by the manufacturer.
- When replacing batteries pay attention to the polarity (the positive + and negative - ends of the battery); be sure to install the batteries in the correct position and proper direction.
- Properly dispose of used batteries according to the battery manufacturer's instructions or according to your local environmental regulations and disposal guidelines.
- Never dispose of any batteries in fire! The batteries may leak or explode.
- The back-up power system: When you are not using your cash register, keep it plugged in with the cash register turned OFF. If the unit is unplugged, back-up power for the memory is provided through the batteries, but this should not be used for long periods of time.

FEDERAL COMMUNICATIONS COMMISSION (FCC) RADIO FREQUENCY INTERFERENCE STATEMENT INFORMATION TO THE USER

CAUTION: Changes or modifications to this unit not expressly approved by the party responsible for compliance could void the user's authority to operate the equipment.

NOTE: This equipment has been tested and found to comply with the limits for a Class B digital device, pursuant to Part 15 of the FCC Rules. These limits are designed to provide reasonable protection against harmful interference in a residential installation. This equipment generates, uses and can radiate radio frequency energy and, if not installed and used in accordance with the instructions, may cause harmful interference to radio communications. However, there is no guarantee that interference will not occur in a particular installation. If this equipment does cause harmful interference to radio or television reception, which can be determined by turning the equipment off and on, the user is encouraged to try to correct the interference by one or more of the following measures:

1. Reorient or relocate the receiving antenna.
2. Increase the separation between the equipment and receiver.
3. If applicable, connect the equipment into an outlet on a circuit different from that to which the receiver is connected.

Consult the dealer or an experienced radio / TV technician for assistance.
 Connection of peripherals to this unit requires the use of grounded, shielded cables to ensure compliance with the Class B FCC limits.

IN CANADA:
 This digital apparatus does not exceed the Class limits for radio noise emissions from digital apparatus set forth in the Radio Interference Regulations of the Canadian Department of Communications.

- Safety and Legal Notices**
- The power outlet for this cash register must be located near the unit and be easily accessible.
 - Do not use this cash register outdoors in the rain or near any source of liquid, such as a pool.

Software Licensing Agreement

TERMS. The product which you have purchased from Royal contains software ("the Software") which is owned by Royal and/or third parties which have provided the same to Royal and which is protected by the United States copyright laws and treaty provisions. By purchasing this product containing the Software, you are agreeing to be bound by the terms of this license. If you do not agree to this license, you must not use the product but rather immediately return it to your point of purchase for a full refund.

Any such return must be made within any applicable time period established for returns at the point of purchase, but in no event later than 30 days after purchase. Your use of the product shall be deemed acceptance of this license.

GRANT OF LICENSE. With the purchase of your product from Royal, Royal grants you the right to use the Software, which is contained in the product. This grant is only for the specific person, which has purchased the product. In other words, the license, which accompanies each product, is only for one person.

RESTRICTIONS. You may not copy the Software, decompile it, duplicate it, modify it or reverse engineer it in any fashion.

RIGHTS. The Software is provided to you in an "as is" condition by Royal. ROYAL MAKES NO WARRANTY WHATSOEVER WITH RESPECT TO THE SOFTWARE AND ALL EXPRESS OR IMPLIED WARRANTIES, INCLUDING ANY IMPLIED WARRANTY OF MERCHANTABILITY, FITNESS FOR A PARTICULAR PURPOSE OR NON-INFRINGEMENT, ARE SPECIFICALLY DISCLAIMED. All other rights with respect to the Software, except as set forth in this license, are specifically retained by Royal or the owner of the Software. Nothing in this license constitutes a waiver of any rights Royal or the owners of the Software may have under any applicable copyright law or any other United States federal or state law.

GOVERNING LAW. This license is governed by the laws of the State of New Jersey.

CHAPTER 8: PRODUCT INFORMATION

Manufacturer's Limited Warranty

ROYAL ELECTRONIC CASH REGISTER AND TIME CLOCK LIMITED WARRANTY

Royal Consumer Information Products, Inc. ("Royal") at 379 Campus Drive, 2nd Floor, in Somerset, NJ 08875 USA warrants that your NEW Royal Electronic Cash Register or Time Clock ("Product") is free of defects of workmanship and materials. If there is a defect or malfunction of this Product, Royal will repair the Product free of charge as follows:

PARTS: New or comparable rebuilt parts in exchange for defective parts for ONE YEAR from the date of purchase.

LABOR: All labor charges incurred from a Royal Authorized Service Center or the Royal Corporate Service Center are covered for 90 DAYS from the date of purchase. After 90 days there will be a labor charge for repair of the Product and/or assemblies such as the keyboard, display(s), logic board, power supply and printer(s) at the Royal Corporate Service Center's or the Royal Authorized Service Center's then prevailing rates. The Product must be brought to a Royal Authorized Service Center nearest to your location; or the Product must be shipped postage prepaid, insured and via a traceable shipping method to a Royal Authorized Service Center or to the Royal Corporate Service Center. Royal will pay return postage from the Royal Corporate Service Center during the labor warranty period only.

This warranty does not apply to persons who purchased this Product second hand or used.

This warranty does not include the replacement of ink rolls, ribbons, time cards, paper rolls or any other consumable or supplies used in the cash register or time clock and consumed through the normal use of the Product.

This warranty does not include cleaning, adjustments, parts, or repairs required by circumstances beyond the control of Royal, including, but not limited to, fire or other casualty, accident, neglect, abuse, abnormal use, misuse or battery leakage damages. THERE ARE NO OTHER EXPRESSED WARRANTIES EXCEPT AS STATED HEREIN. AFTER THE PERIOD OF EXPRESSED WARRANTY SET FORTH HEREIN, THERE ARE NO EXPRESSED OR IMPLIED WARRANTIES AND THOSE EXCLUDED INCLUDE THOSE OF MERCHANTABILITY AND FITNESS FOR A PARTICULAR PURPOSE. Royal shall NOT be liable for CONSEQUENTIAL DAMAGES resulting from any failure, defect, or malfunction of this Product. Some states do not allow limitations on how long an implied warranty lasts and some states do not allow the exclusion or limitation of incidental or consequential damages, so the above limitations or exclusions may not apply to you.

TO OBTAIN SERVICE UNDER THE TERMS OF THIS WARRANTY:

• Pack your Product in the original carton or equivalent.

• Enclose a copy of the bill of sale or other documentation showing original purchase date.

• Enclose a card or note describing the difficulty you have had with the Product.

• Be sure to include your complete name, address and day-time telephone number.

• Bring or ship, prepaid and insured, via a traceable shipping method the above Product to the nearest Royal Authorized Service Center location or to the Royal Corporate Service Center. Royal and/or the Service Center cannot be held responsible for any loss or damage that occurs while in transit.

For Authorized Service Centers within your local area, call 1-888-261-3888 or 1-800-272-6229. In Canada call 1-888-266-9380. Or you can call the Royal Corporate Service Center directly at 1-630-315-2603 for shipping instructions and additional information.

Please retain the original proof of purchase for your records to establish date of original purchase. Your warranty starts with the date of original purchase. This warranty gives you specific legal rights, and you may also have other rights which vary from State to State.

This warranty is valid only on cash registers and time clocks purchased, delivered and used in the United States and/or Canada.