

About This Manual

The instructions in this manual are for models STR-DE625 and DE525. Check your model number by looking at the upper right corner of the front panel. In this manual, the USA and Canadian STR-DE625 is used for illustration purposes unless stated otherwise. Any difference in operation is clearly indicated in the text, for example, "STR-DE625 only."

Type of differences

Feature	Model	DE625	DE525
Three video inputs		●	
Control A1/Control S		●	
IMPEDANCE SELECTOR for the front speakers		●	

Conventions

- The instructions in this manual describe the controls on the receiver. You can also use the controls on the supplied remote if they have the same or similar names as those on the receiver. For details on the use of your remote, refer to the separate operating instructions supplied with the remote.
- The following icon is used in this manual:
☞ Indicates hints and tips for making the task easier.

This receiver incorporates the Dolby* Pro Logic Surround system.

* Manufactured under license from Dolby Laboratories Licensing Corporation. DOLBY, the double-D symbol , "PRO LOGIC," and Dolby Digital (AC-3) are trademarks of Dolby Laboratories Licensing Corporation.

STR-DE 625
♀
STR-DE 525

TABLE OF CONTENTS

Hooking Up the Components 4

- Unpacking 4
- Antenna Hookups 5
- Audio Component Hookups 6
- Video Component Hookups 7
- 5.1 Input Hookups 9
- Other Hookups 10

Hooking Up and Setting Up the Speaker System 13

- Speaker System Hookup 14
- Dolby Surround Setup 15
- Before You Use Your Receiver 17

Location of Parts and Basic Amplifier Operations 20

- Front Panel Parts Description 20

Enjoying Surround Sound 24

- Selecting a Sound Field 25
- Customizing Sound Fields 27

Receiving Broadcasts 29

- Direct Tuning 30
- Automatic Tuning 31
- Preset Tuning 31

Other Operations 33

- Indexing Preset Stations and Program Sources 34
- Recording 34
- Using the Sleep Timer 35
- Adjustments Using the SET UP Button 36

Additional Information 37

- Troubleshooting 37
- Specifications 39
- Glossary 41
- Tables of Settings Made Using the CURSOR MODE and SET UP Buttons 42
- Index 43

WARNING

To prevent fire or shock hazard, do not expose the unit to rain or moisture.

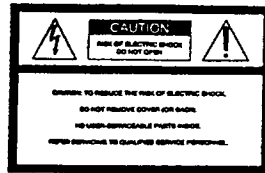

This symbol is intended to alert the user to the presence of uninsulated "dangerous voltage" within the product's enclosure that may be of sufficient magnitude to constitute a risk of electric shock to persons.



This symbol is intended to alert the user to the presence of important operating and maintenance (servicing) instructions in the literature accompanying the appliance.

INFORMATION

This equipment has been tested and found to comply with the limits for a Class B digital device, pursuant to Part 15 of the FCC Rules.

These limits are designed to provide reasonable protection against harmful interference in a residential installation. This equipment generates, uses, and can radiate radio frequency energy and, if not installed and used in accordance with the instructions, may cause harmful interference to radio communications.

However, there is no guarantee that interference will not occur in a particular installation. If this equipment does cause harmful interference to radio or television reception, which can be determined by turning the equipment off and on, the user is encouraged to try to correct the interference by one or more of the following measures:

- Reorient or relocate the receiving antenna.
- Increase the separation between the equipment and receiver.
- Connect the equipment into an outlet on a circuit different from that to which the receiver is connected.
- Consult the dealer or an experienced radio/TV technician for help.

CAUTION

You are cautioned that any changes or modification not expressly approved in this manual could void your authority to operate this equipment.

Note to CATV system installer:

This reminder is provided to call CATV system installer's attention to Article 820-40 of the NEC that provides guidelines for proper grounding and, in particular, specifies that the cable ground shall be connected to the grounding system of the building, as close to the point of cable entry as practical.

Owner's Record

The model and serial numbers are located on the rear of the unit. Record the serial number in the space provided below. Refer to them whenever you call upon your Sony dealer regarding this product.

Model No. STR-DE625/DE525

Serial No. _____

For the customers in Canada

CAUTION

TO PREVENT ELECTRIC SHOCK, DO NOT USE THIS POLARIZED AC PLUG WITH AN EXTENSION CORD, RECEPTACLE OR OTHER OUTLET UNLESS THE BLADES CAN BE FULLY INSERTED TO PREVENT BLADE EXPOSURE.

Precautions

On safety

Should any solid object or liquid fall into the cabinet, unplug the receiver and have it checked by qualified personnel before operating it any further.

On power sources

- Before operating the receiver, check that the operating voltage is identical with your local power supply. The operating voltage is indicated on the nameplate at the rear of the receiver.
- The unit is not disconnected from the AC power source (mains) as long as it is connected to the wall outlet, even if the unit itself has been turned off.
- If you are not going to use the receiver for a long time, be sure to disconnect the receiver from the wall outlet. To disconnect the AC power cord, grasp the plug itself; never pull the cord.
- One blade of the plug is wider than the other for the purpose of safety and will fit into the wall outlet only one way. If you are unable to insert the plug fully into the outlet, contact your dealer.
- AC power cord must be changed only at the qualified service shop.

On placement

- Place the receiver in a location with adequate ventilation to prevent heat buildup and prolong the life of the receiver.
- Do not place the receiver near heat sources, or in a place subject to direct sunlight, excessive dust or mechanical shock.
- Do not place anything on top of the cabinet that might block the ventilation holes and cause malfunctions.

On operation

Before connecting other components, be sure to turn off and unplug the receiver.

On cleaning

Clean the cabinet, panel and controls with a soft cloth slightly moistened with a mild detergent solution. Do not use any type of abrasive pad, scouring powder or solvent such as alcohol or benzene.

If you have any question or problem concerning your receiver, please consult your nearest Sony dealer.

Hooking Up the Components

This chapter describes how to connect various audio and video components to the receiver. Be sure to read the sections for the components that you have before you actually connect them to the receiver.

Unpacking

Check that you received the following items with the receiver:

- FM wire antenna (1)
- AM loop antenna (1)
- Remote commander (remote) (1)

Model	Remote
STR-DE625	RM-LJ301
STR-DE525 (except Canada)	RM-U401
STR-DE525 (Canada)	RM-PP401

- R6 (size-AA) batteries (2)
- R6 (size-AA) batteries (3) (STR-DE625 only)
- Operating Instructions of the remote
- Audio/video/control S connecting cord (1) (STR-DE625 only)
- Control S connecting cord (1) (STR-DE625 only)

Inserting batteries into the remote

Insert two size-AA (R6) batteries with the + and - properly oriented in the battery compartment. When using the remote, point it at the remote sensor  on the receiver.

For details, refer to the operating instructions supplied with your remote.

When to replace batteries

Under normal conditions, the batteries should last for about 6 months. When the remote no longer operates the receiver, replace both batteries with new ones.

Notes

- Do not leave the remote in an extremely hot or humid place.
- Do not use a new battery with an old one.
- Do not expose the remote sensor to direct sunlight or lighting apparatuses. Doing so may cause a malfunction.
- If you don't use the remote for an extended period of time, remove the batteries to avoid possible damage from battery leakage and corrosion.

Before you get started

- Turn off the power to all components before making any connections.
- Do not connect the AC power cords until all of the connections are completed.
- Be sure to make connections firmly to avoid hum and noise.
- When connecting an audio/video cord, be sure to match the color-coded pins to the appropriate jacks on the components: yellow (video) to yellow; white (left, audio) to white; and red (right, audio) to red.

Antenna Hookups

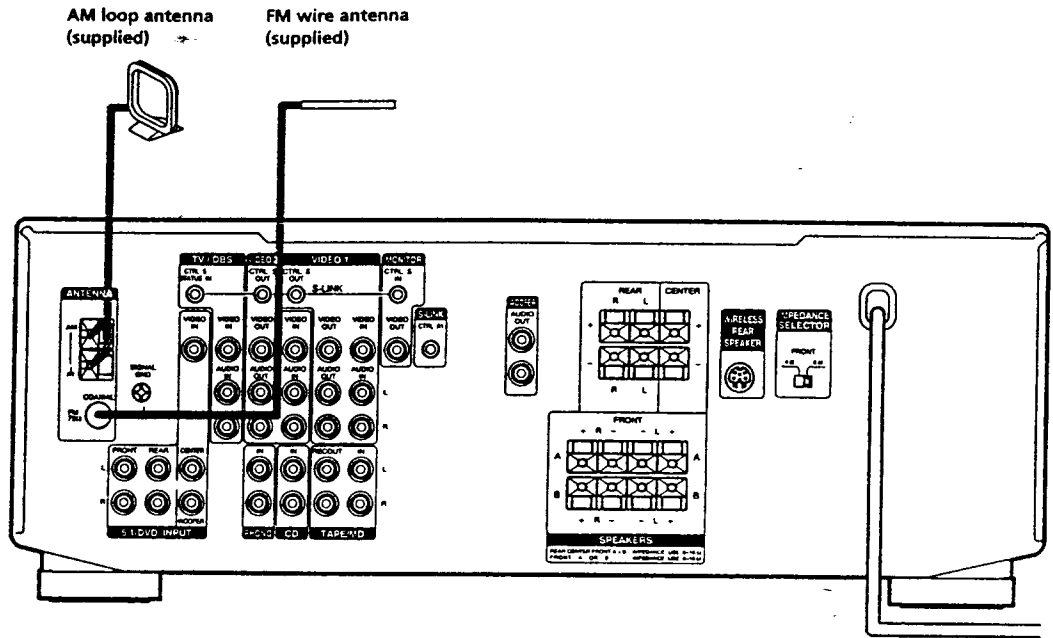

Terminals for connecting the antennas

Connect the	To the
AM loop antenna	AM terminals
FM wire antenna	FM 75Ω COAXIAL terminal

Notes on antenna hookups:

- To prevent noise pickup, keep the AM loop antenna away from the receiver and TV.
- After connecting the FM wire antenna, keep it as horizontal as possible.

💡 If you have poor FM reception

Use a 75-ohm coaxial cable (not supplied) to connect the receiver to an outdoor FM antenna as shown below.

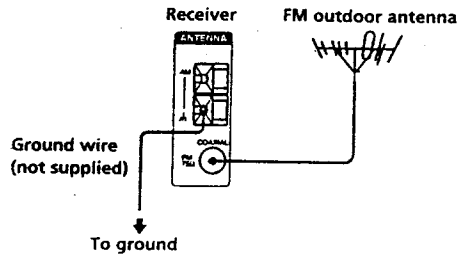

Important

If you connect the receiver to an outdoor antenna, ground it against lightning as shown in the illustration in the left column. To prevent a gas explosion, do not connect the ground wire to a gas pipe.

Note

Do not use the SIGNAL GND terminal for grounding the receiver.

Audio Component Hookups

Hooking Up the Components

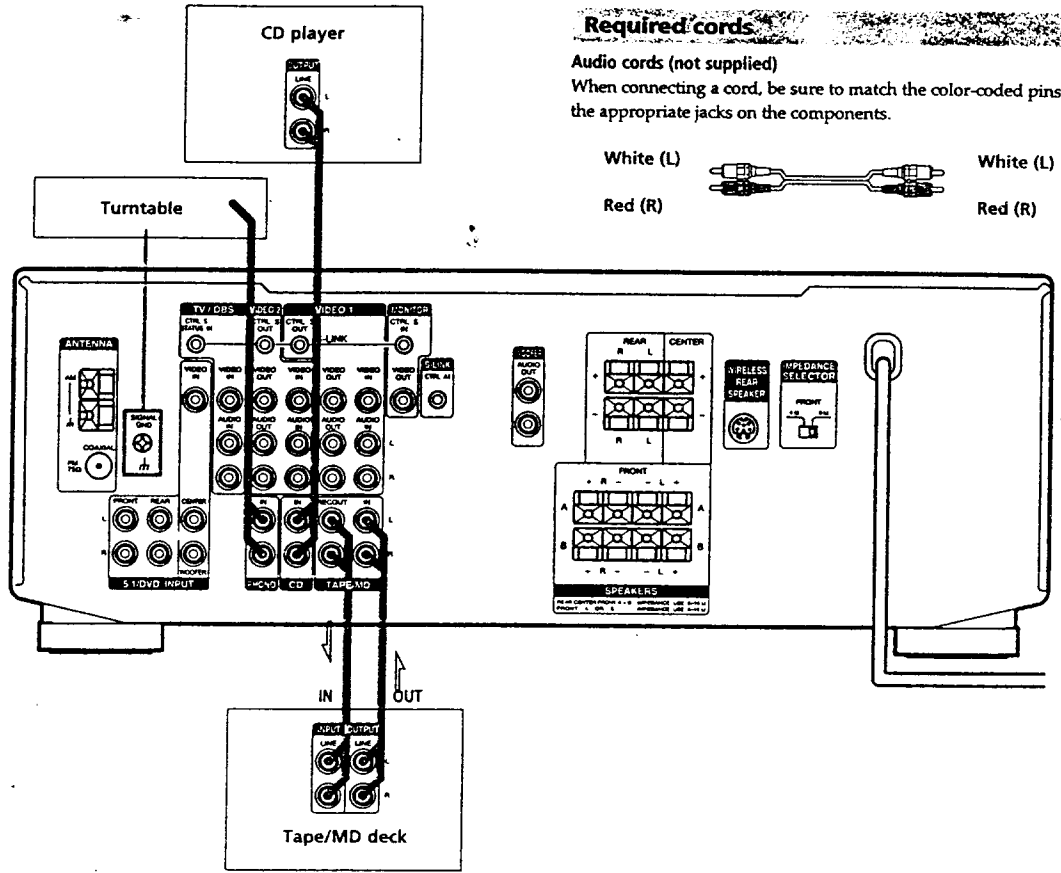

Required cords

Audio cords (not supplied)

When connecting a cord, be sure to match the color-coded pins to the appropriate jacks on the components.

White (L)

Red (R)



White (L)

Red (R)

Jacks for connecting audio components

Connect a	To the
Turntable	PHONO jacks
CD player	CD jacks
Tape deck or MD deck	TAPE/MD jacks

Note on audio component hookups

If your turntable has a ground wire, connect it to the SIGNAL GND terminal on the receiver.

Video Component Hookups

STR-DE625

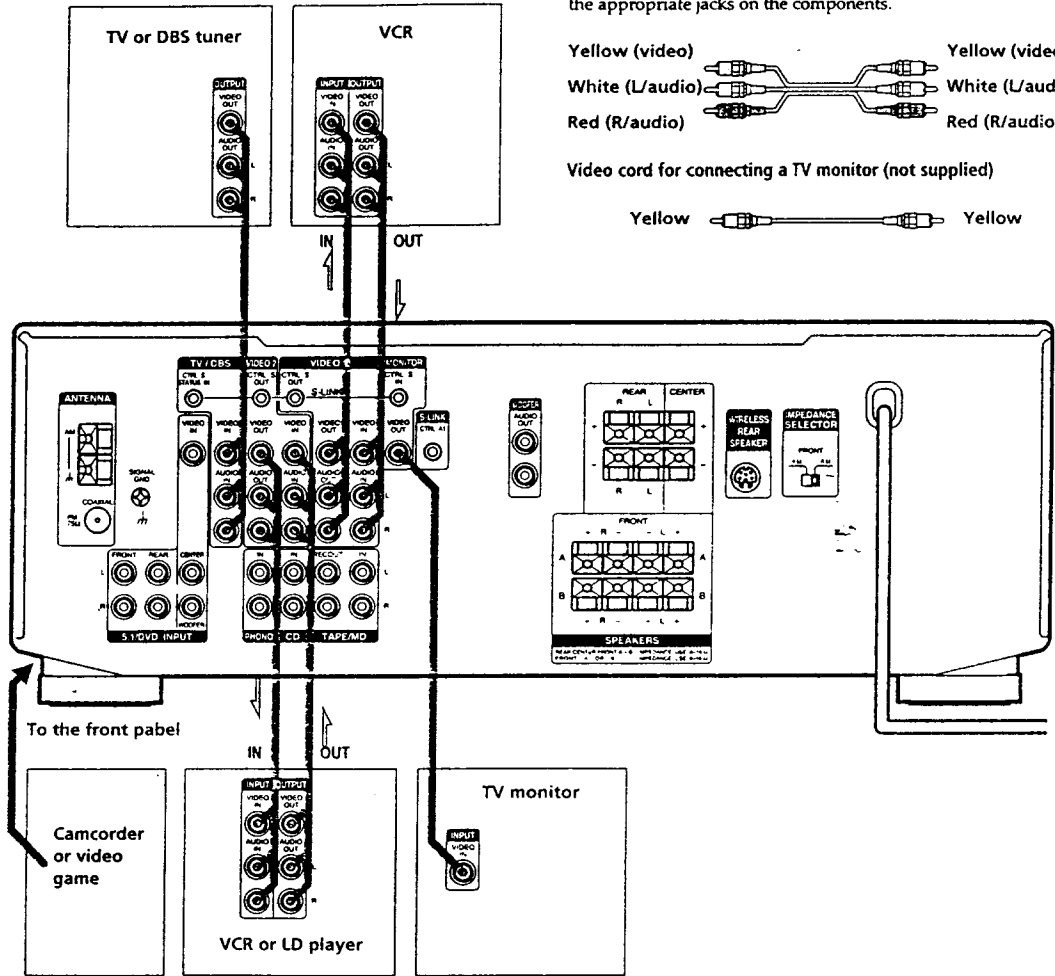

Required cords

Audio/video cords (not supplied)

When connecting a cord, be sure to match the color-coded pins to the appropriate jacks on the components.

Yellow (video)
 White (L/audio)
 Red (R/audio)

Video cord for connecting a TV monitor (not supplied)

Yellow ——— Yellow

Jacks for connecting video components

Connect a	To the
TV or DBS tuner	TV/DBS jacks
VCR	VIDEO 1 jacks
Additional VCR or LD player	VIDEO 2 jacks
TV monitor	MONITOR VIDEO OUT jack
Camcorder or video game	VIDEO 3 INPUT jacks on the front panel

Note on video component hookups

You can connect your TV's audio output jacks to the TV/DBS AUDIO IN jacks on the receiver to apply Dolby Pro Logic Surround effects on the audio from the TV. In this case, do not connect the video output jack on the TV to the TV/DBS VIDEO IN jack on the receiver. If you connect a TV tuner (or a DBS tuner), connect the audio and video output jacks to the receiver as shown above.

Video Component Hookups

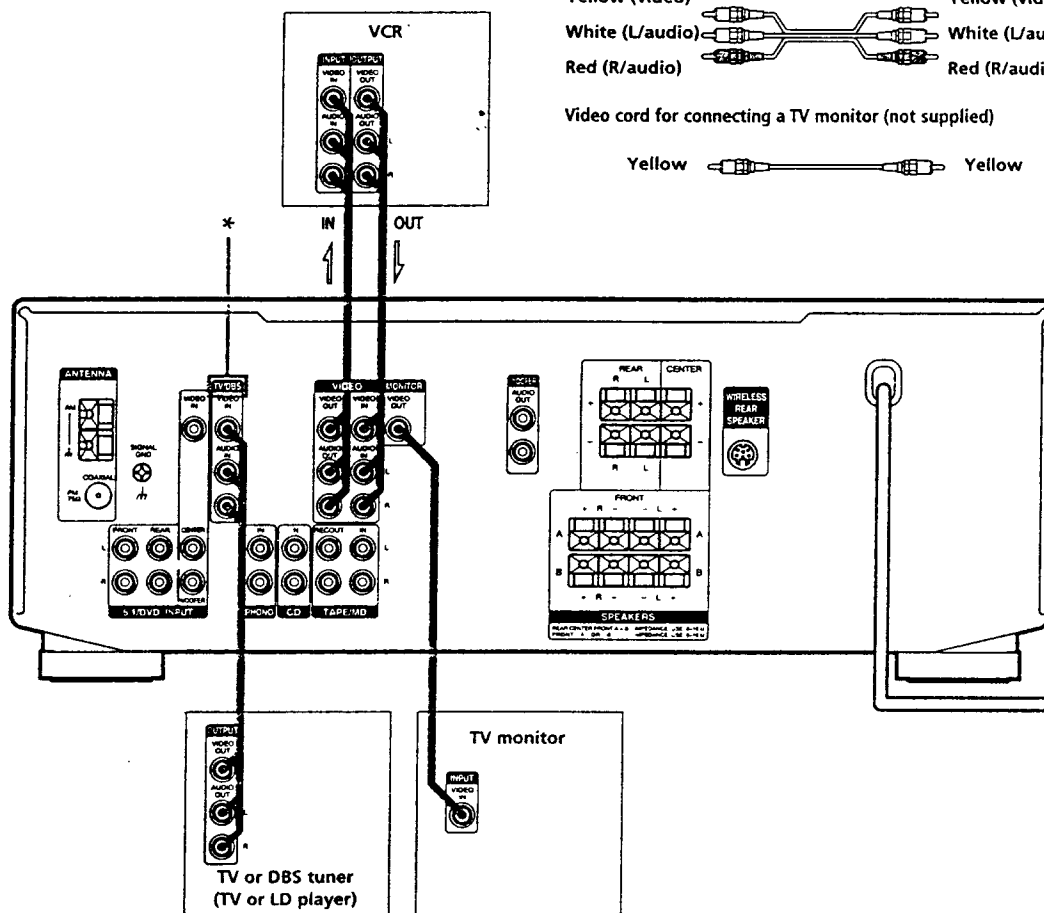

STR-DE525

Hooking Up the Components



Required cords

Audio/video cords (not supplied)

Yellow (video)  Yellow (video)
 White (L/audio)  White (L/audio)
 Red (R/audio)  Red (R/audio)

Video cord for connecting a TV monitor (not supplied)

Yellow  Yellow

* TV/DBS (Direct Broadcasting Satellite): USA, Canada, and Australia
 TV/LD: all countries except USA, Canada, and Australia

Jacks for connecting video components

Connect a	To the
TV or DBS tuner (TV or LD player)	TV/DBS or TV/LD jacks
VCR	VIDEO jacks
TV monitor	MONITOR jack

Note on video component hookups

You can connect your TV's audio output jacks to the TV/DBS (or TV/LD) AUDIO IN jacks on the receiver to apply Dolby Pro Logic Surround effects on the audio from the TV. In this case, do not connect the video output jack on the TV to the TV/DBS (or TV/LD) VIDEO IN jack on the receiver. If you connect a TV tuner (or a DBS tuner), connect the audio and video output jacks to the receiver as shown above.

5.1 Input Hookups

This receiver is equipped with 5.1/DVD INPUT jacks. By connecting your DVD player or other digital video source through a multi-channel decoder (e.g., Dolby Digital (AC-3) decoder) to these jacks, you can enjoy theater-quality Multi-Channel Surround sound in your own home. To enjoy Multi-Channel Surround sound to its full extent, you will need five speakers (two front speakers, two rear speakers, and a center speaker) and a subwoofer. Refer to the instruction manual supplied with your Dolby Digital (AC-3) decoder etc., for details on the 5.1-channel input hookups.

Required cords

Audio cords (not supplied)
Two for the 5.1/DVD INPUT FRONT and REAR jacks

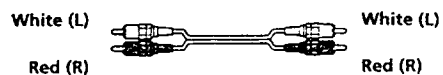

Monaural audio cords (not supplied)
Two for the 5.1/DVD INPUT CENTER and WOOFER jacks

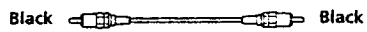

Video cord (not supplied)
One for the 5.1/DVD INPUT VIDEO IN jacks

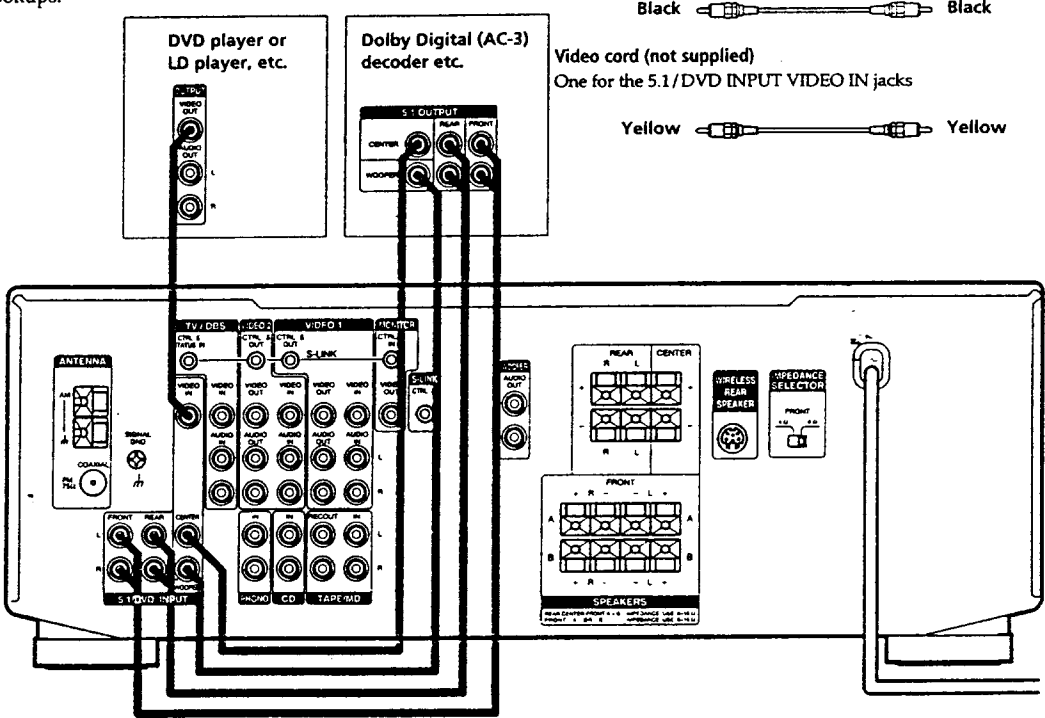
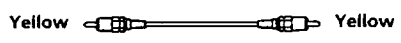

Example of Dolby Digital system hookup using the 5.1/DVD INPUT jacks

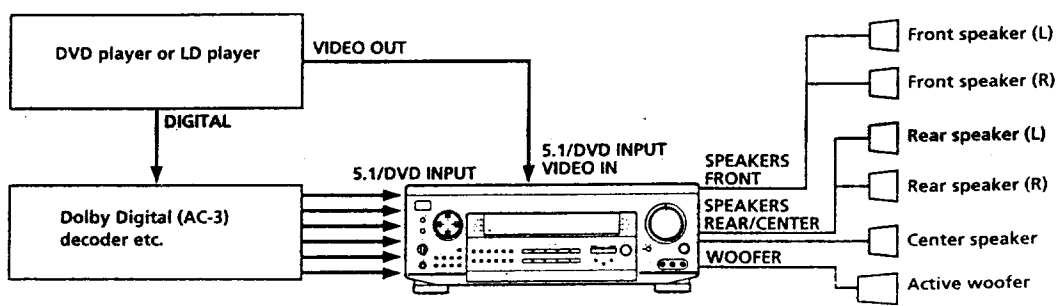

- DVD players with a built-in Dolby Digital (AC-3) decoder can be connected directly to the 5.1/DVD INPUT jacks on the receiver.

Other Hookups

Hooking Up the Components

Required cords

Audio/video/control S connecting cord (1) (supplied with STR-DE625 only)

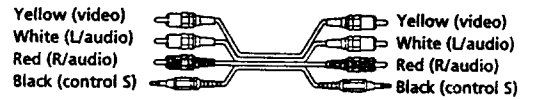

Control S connecting cord (1) (supplied with STR-DE625 only)

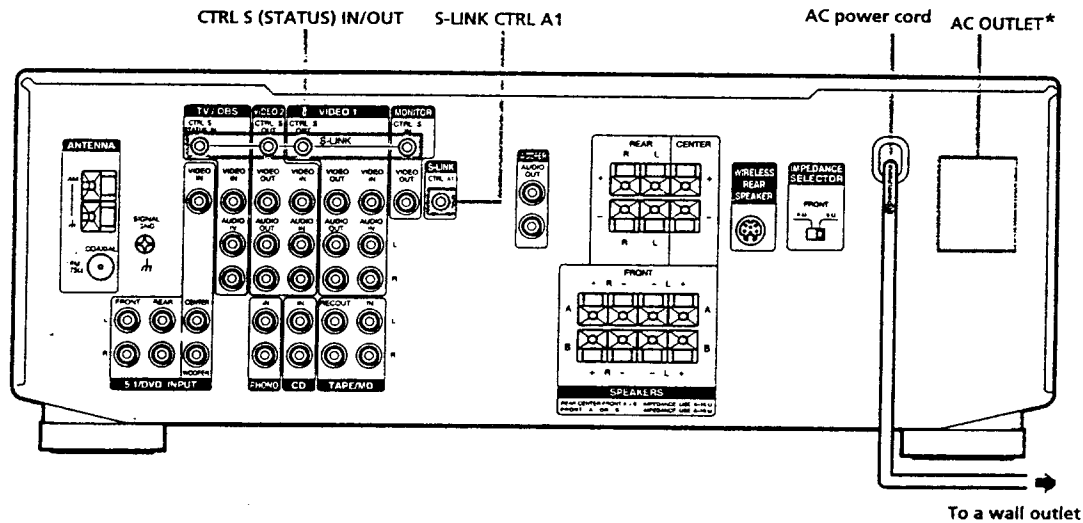
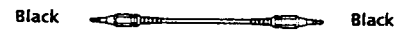

* The configuration, shape, and number of AC outlets on the rear panel varies according to the model and country to which the receiver is shipped.

Other Hookups

Connecting the AC power cord

Before connecting the AC power cord of this receiver to a wall outlet:

- Connect the speaker system to the receiver (see page 14).
- Turn the MASTER VOLUME control to the leftmost position (0).

Connect the AC power cord(s) of your audio/video component(s) to a wall outlet.

If you connect other audio/video components to AC OUTLET on the receiver, the receiver will supply power to the connected component(s), allowing you to turn on or off the whole system when you turn on/off the receiver.

Caution

Make sure that the total power consumption of the component(s) connected to the receiver's AC OUTLET does not exceed the wattage stated on the rear panel. Do not connect high-wattage electrical home appliances such as electric irons, fans, or TVs to this outlet.

CONTROL S hookup (STR-DE625 only)

If you have a CONTROL S-compatible Sony TV, DBS tuner, monitor, or VCR, use an audio/video/control S connecting cord (supplied) or a control S connecting cord (supplied) to connect the CTRL S (STATUS) IN (for TV, DBS tuner, or monitor) or OUT (for VCR etc.) jack on the receiver to the appropriate S-LINK jack on the respective component. Refer to the operating instructions supplied with your TV, DBS tuner, monitor, VCR, etc., for details.

An example of a CONTROL S hookup between the receiver and TV or VCR is shown below. When your TV is connected to the receiver as shown below, the TV input mode will change to video input whenever you turn on the receiver. When you connect the VCR to the receiver as shown below, the input mode of the receiver changes to video 1 (or 2) whenever you turn on the VCR.

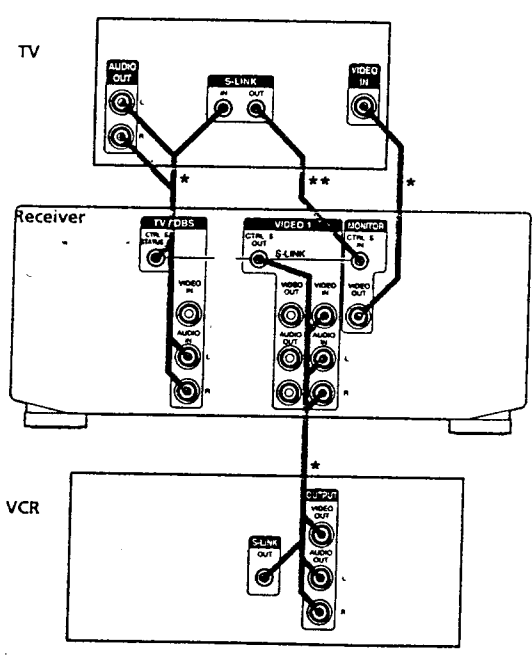

* Audio/video/control S connecting cord
 ** Control S connecting cord

CONTROL A1 hookup (STR-DE625 only)

• **If you have a CONTROL A1-compatible Sony CD player, tape deck, or MD deck**

Use a CONTROL A1 cord (not supplied) to connect the S-LINK CTRL A1 jack on the CD player, tape deck, or MD deck to the S-LINK CTRL A1 jack on the receiver. See "Displaying the operating status of the component connected to the S-LINK CTRL A1 jack" on page 36 and refer to the separate manual "CONTROL-A1 Control System" and the operating instructions supplied with your CD player, tape deck, or MD deck for details.

• **If you have a Sony CD changer with a COMMAND MODE selector**

If your CD changer's COMMAND MODE selector can be set to CD 1, CD 2, or CD 3, be sure to set the command mode to "CD 1" and connect the changer to the CD jacks on the receiver. If, however, you have a Sony CD changer with VIDEO OUT jacks, set the command mode to "CD 2" and connect the changer to the VIDEO 2 jacks on the receiver.

Setting the voltage selector (only on models supplied with a voltage selector)

Check that the voltage selector on the rear panel of the receiver is set to the local power supply voltage. If not, use a screwdriver to set the selector to the correct position before connecting the AC power cord to a wall outlet.

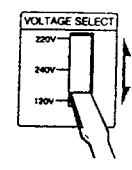

Hooking Up and Setting Up the Speaker System

This chapter describes how to hook up your speaker system to the receiver, how to position each speaker, and how to set up your speakers to enjoy Dolby Surround sound.

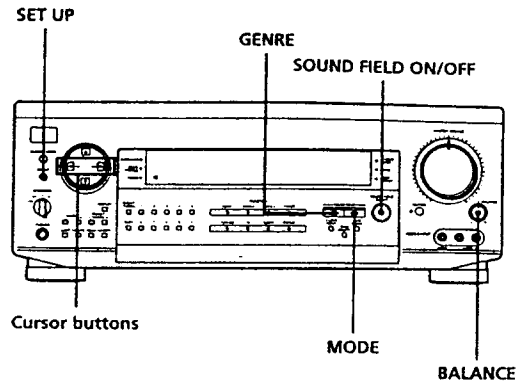

Brief descriptions of buttons and control used to set up the speaker system

SET UP button: Used to display "CTR MODE" when selecting the center mode.

GENRE button: Used to select "CINEMA" when adjusting the speaker volume.

SOUND FIELD ON/OFF button: Turns the sound field mode on or off.

Cursor buttons (</>): Used to select the center mode after pressing the SET UP button.

MODE button: Used to select "PRO LOGIC" when adjusting the speaker volume.

BALANCE control: Used to adjust the front speaker balance while outputting a test tone.

Speaker System Hookup

Required cords

Speaker cords (not supplied)

One for each front, rear, and center speaker



Monaural audio cord (not supplied)

One for an active woofer

Black Black

Hooking Up and Setting Up the Speaker System

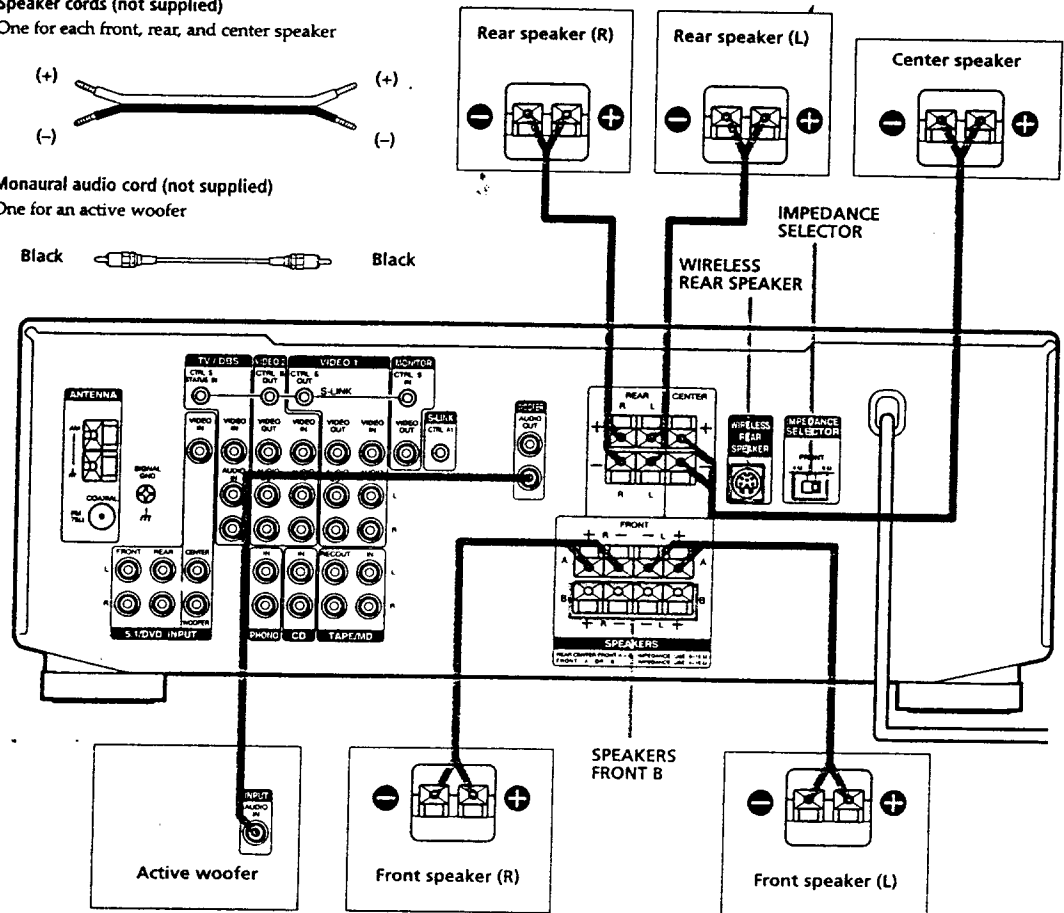

Terminals for connecting the speakers

Connect the	To the
Front speakers	SPEAKERS FRONT A terminals
Additional pair of front speakers	SPEAKERS FRONT B terminals
Rear speakers	SPEAKERS REAR terminals
Center speaker	SPEAKERS CENTER terminals
Active woofer	WOOFER AUDIO OUT jack*
Wireless rear speaker transmitter	WIRELESS REAR SPEAKER jack

* You can connect the active woofer to either of the two jacks. The remaining jack can be used to connect a second active woofer.

Notes on speaker system hookup

- Twist the stripped ends of the speaker cords about 2/3 inch (15 mm). Be sure to match the speaker cord to the appropriate terminal on the components: + to + and - to -. If the cords are reversed, the sound will be distorted and will lack bass.
- If you use front speakers with low maximum input rating, adjust the volume carefully to avoid excessive output on the speakers.
- If you are not using a Sony wireless rear speaker system, do not connect any other component to the WIRELESS REAR SPEAKER jack.

Selecting the impedance (STR-DE625 only)

Set the IMPEDANCE SELECTOR for the front speakers as indicated in the table below. Check the instruction manual of your speakers if you're not sure of the impedance. (This information is usually printed on a label on the back of the speaker.)

If the nominal impedance of your speaker is	Set IMPEDANCE SELECTOR to
Between 4 and 8 ohms	4Ω
8 ohms or higher	8Ω

Note

Be sure to connect the front speakers with nominal impedance of 8 ohms or higher if you want to select both sets of front speakers (see page 21).

Dolby Surround Setup

Dolby Pro Logic Surround is a system for decoding Dolby Surround sound that is standardized for TV programs and movies. By selecting the proper center mode and adjusting the speaker volume (see page 16), you can reproduce highly precise localization and dynamic panning of sounds of Dolby Pro Logic Surround-encoded software.

To obtain the best possible surround effect, you will require at least one additional pair of speakers and/or a center speaker.

Locating the speakers

For optimum Dolby Pro Logic Surround sound, locate your speakers as shown below.

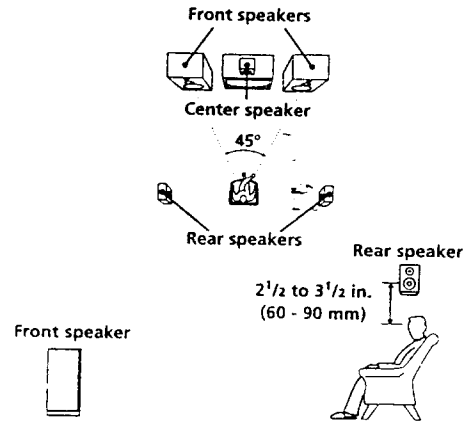

Dolby Surround Setup

Selecting the center mode

The receiver offers you four center modes: PHANTOM, 3CH LOGIC, NORMAL, and WIDE. Each mode is designed for a different speaker configuration. Select the mode that best suits the speakers you use.

- 1 Press SET UP repeatedly until "CTR MODE" (center mode) appears in the display.
- 2 Press the cursor buttons (< or >) to select the center mode you want.

A description of each center mode is as follows:

If you have	Select	So that
Front and rear speakers, but no center speaker	PHANTOM	The sound of the center channel is output from the front speakers
Front and center speakers, but no rear speaker	3CH LOGIC (3-STEREO)	The sound of the rear channel is output from the front speakers
Front and rear speakers, and a small center speaker	NORMAL	The bass sound of the center channel is output from the front speakers (because a small speaker cannot produce enough bass)
Front and rear speakers, and a center speaker that is equivalent to your front speakers	WIDE	Dolby Pro Logic Surround sound is fully reproduced

Adjusting the speaker volume

The test tone feature lets you set the volume of your rear speakers and/or center speaker to the same level as that of the front speakers to maximize the Dolby Pro Logic Surround effect. (If all of your speakers are equal in performance, you don't have to adjust the speaker volume.)

Using the controls on the remote, you can adjust the volume level from wherever you're listening.

- 1 Make sure that the center mode is correctly set (see the table on this page).
- 2 Press SOUND FIELD ON/OFF to turn on the sound field.
- 3 Press GENRE repeatedly to select "CINEMA."

- 4 Press MODE repeatedly to select "PRO LOGIC."

- 5 Press TEST TONE on the supplied remote. You will hear a test tone (see this page) from each speaker sequentially.

- 6 Adjust the volume level so that the volume of the test tone from each speaker sounds the same from where you are listening.

- To adjust the balance of the front right and front left speakers, use the BALANCE control on the front of the main unit.
- To adjust the volume level of the center speaker, press the LEVEL CENTER +/- buttons on the remote.
- To adjust the volume level of the rear speakers, press the LEVEL REAR +/- buttons on the remote.

- 7 Press TEST TONE on the remote again to turn off the test tone.

💡 You can adjust the volume level of all speakers at the same time

Rotate MASTER VOLUME on the main unit or press MASTER VOLUME +/- on the remote.

💡 What is a test tone?

A test tone is a signal that is produced by the receiver and used to adjust speaker volume. The test tone is output from speakers in the following two ways:

- When NORMAL, WIDE, or 3CH LOGIC mode is selected
The test tone is output from the front L (left), center, front R (right), and rear speakers (except for 3CH LOGIC mode) in succession.

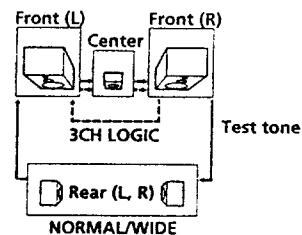

- When PHANTOM mode is selected
The test tone is output from the front and the rear speakers alternately.

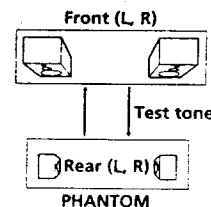

See the table on page 28 for information on the output of the test

Before You Use Your Receiver

Before turning on the receiver

Make sure that you have:

- Turned MASTER VOLUME to the leftmost position (0).
- Selected the appropriate front speakers (see "[8] SPEAKERS selector" on page 21).
- Set BALANCE to the center position.

Clearing the receiver's memory

Before you use your receiver for the first time or when you want to clear the receiver's memory, do the procedure below.

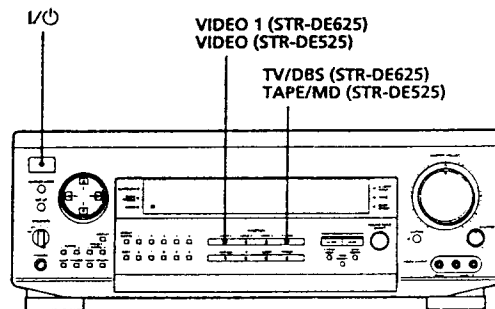

- 1 Turn off the receiver.
- 2 While pressing down VIDEO 1 and TV/DBS (STR-DE625) or VIDEO and TAPE/MD (STR-DE525), press I/Power to turn on the receiver. "ALL CLEAR" appears in the display and the items including the following are reset or cleared:
 - All preset stations are reset to their factory settings.
 - All sound field parameters are reset to their factory settings.
 - All index names (of preset stations and program sources) are cleared.
 - All adjustments made with the SET UP button are reset to their factory settings.
 - The sound field memorized for each program source and preset station is cleared.

Checking the connections

After connecting all of your components to the receiver, do the procedure below to verify that the connections were correctly made.

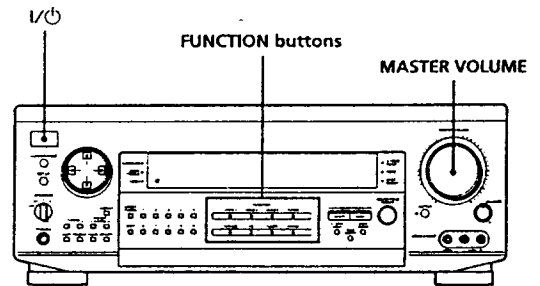

- 1 Press I/Power to turn on the receiver.
- 2 Press a FUNCTION button to select a component (program source) that you have connected (e.g., CD player or tape deck).
- 3 Turn on the component and start playing it.
- 4 Rotate MASTER VOLUME to turn up the volume.

If you did not obtain normal sound output after performing the procedure above, look for the reason in the following check-list and take the appropriate measures to correct the problem.

There is no sound no matter which component is selected.

- ➔ Check that both the receiver and all components are turned on.
- ➔ Check that the MASTER VOLUME control is not set at 0.
- ➔ Check that the SPEAKERS selector is not set at OFF or at a position for front speakers that are not connected to the receiver (see "[8] SPEAKERS selector" on page 21).
- ➔ Check that all the speaker cords are connected correctly.
- ➔ Press the MUTING button to turn off the indicator to the left of the button.

Before You Use Your Receiver

There's no sound from a specific component.

- Check that the component is connected correctly to the audio input jacks for that component.
- Check that the cord(s) used for the connection is (are) inserted fully into the jacks on both the receiver and the component.

No sound is heard from one of the front speakers.

- Check that the BALANCE control is set at center position (see "[6] BALANCE control" on page 21).
- Connect a pair of headphones to the PHONES jack and set the SPEAKERS selector to OFF to verify that sound output is from the headphones (see "[8] SPEAKERS selector" and "PHONES jack" on page 21). If both channels are output from the headphones, the front speaker may not be connected to the receiver correctly. Check the connection for the front speaker from which no sound is output.
- If only one channel is output from the connected headphones, the component and the receiver may not be connected correctly. Check that all the cords are fully inserted into the jacks on both the receiver and the component.

If you encounter a problem that is not included above, see "Troubleshooting" on page 37.

Location of Parts and Basic Amplifier Operations

This chapter gives you the information on the location and function of the buttons and controls on the front panel and explains basic amplifier operations.

Front Panel Parts Description

1 I/O switch

Press to turn the receiver on and off.

Note

Before you turn on the receiver, make sure that you have turned the MASTER VOLUME control to the leftmost position to avoid damaging your speakers.

2 FUNCTION buttons

Press one of the buttons to select the component you want to use.

To select	Press
VCR	VIDEO 1 or VIDEO 2 (STR-DE625) VIDEO (STR-DE525)
Camcorder or video game	VIDEO 3 (STR-DE625 only)
TV, DBS tuner*, or LD player	TV/DBS (USA, Canada, and Australia) TV/LD (all countries except USA, Canada, and Australia)
Tape deck or MD deck	TAPE/MD
CD player	CD
Built-in tuner	TUNER
Turntable	PHONO

* DBS tuners can be used in the USA, Canada, and Australia only.

After selecting the component, turn on the component you selected and play the program source.

Notes

- After you have selected VCR, camcorder, video game, or LD player, turn on the TV and set the TV's video input to match the component you selected.
- Press the 5.1/DVD INPUT button to select the component connected to the 5.1/DVD INPUT jacks (see "5.1/DVD

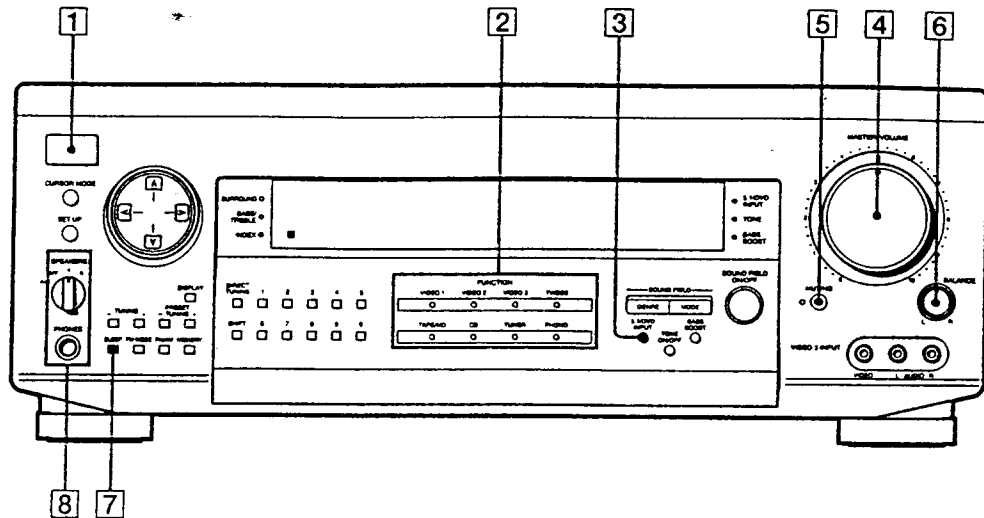

3 5.1/DVD INPUT button

Press to select the component connected to the 5.1/DVD INPUT jacks. The 5.1/DVD INPUT indicator lights up when the component is selected.

Note

When the 5.1/DVD INPUT indicator lights up, the following buttons do not function:

- TONE ON/OFF button
- BASS BOOST button
- SOUND FIELD ON/OFF button
- GENRE button
- MODE button

4 MASTER VOLUME control

After turning on the component you selected, rotate to adjust the volume.

5 MUTING button

Press to mute the sound. The indicator to the left of the button lights up when the sound is muted.

6 BALANCE control

Rotate to adjust the balance of the front speakers.

7 SLEEP button

Press to select the time after which the receiver turns off automatically (see page 35).

8 SPEAKERS selector

Set according to the front speakers you want to drive.

To select	Set to
Speakers connected to the SPEAKERS FRONT A terminals	A
Speakers connected to the SPEAKERS FRONT B terminals	B
Speakers connected to both the SPEAKERS FRONT A and B terminals (parallel connection)	A+B*
No front speaker output	OFF

* Do not set to A+B when a sound field is turned on.

PHONES jack

Connects headphones.

Note

To use the headphones, set the SPEAKERS selector to OFF to output sound to the headphones.

Front Panel Parts Description

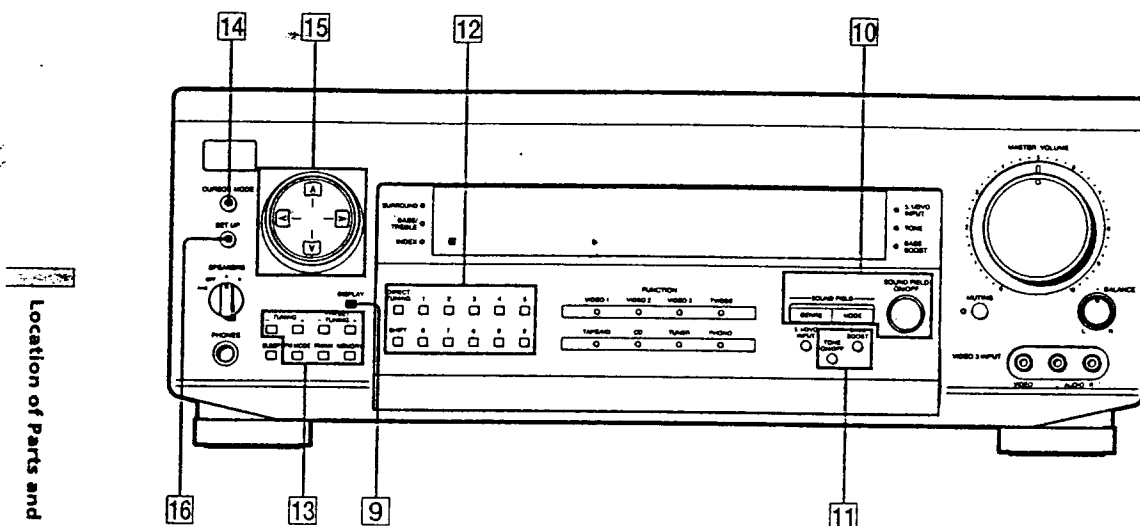

Location of Parts and Basic Amplifier Operations

9 DISPLAY button

Press repeatedly to change the information on the display window as follows:

Index name of the component or the preset station*

+

FUNCTION button indication or frequency**

+

Sound field applied to the program source

* Index name appears only when you have assigned one to the component or the preset station (see page 34).

** Frequency appears only when the tuner is selected.

- 10 Use the following buttons to enjoy surround sound. For details, see "Enjoying Surround Sound" starting from page 24.

GENRE button

Press repeatedly to select "CINEMA" or "MUSIC" sound field group.

MODE button

Press to select a sound field from the group you selected.

SOUND FIELD ON/OFF button

Press to turn the sound field on or off.

11 BASS BOOST button

Press to increase the bass of the front speakers. The BASS BOOST indicator lights up when the function is turned on.

TONE ON/OFF button

Press to turn the tone effect on or off. The TONE indicator lights while the tone effect is turned on. Note that if you have adjusted the tone using the CURSOR MODE button and cursor buttons, the adjusted tone will be produced whenever you turn on the tone effect.

💡 When you want to enjoy high quality sound

Set the SOUND FIELD ON/OFF, BASS BOOST, and the TONE ON/OFF buttons to OFF to bypass the sound field, tone effect, and the bass booster circuits. The result will be a two-channel stereo sound output from the front speakers that is highly faithful to the program source.

- 12 The following buttons operate the built-in tuner. For details, see "Receiving Broadcasts" starting from page 29.

DIRECT TUNING button

Enables Direct Tuning (see page 30).

SHIFT button

Selects a memory page for preset stations.

Numeric buttons (1 to 0)

Inputs the numeric value.

- 13** The following buttons operate the built-in tuner. For details, see "Receiving Broadcasts" starting from page 29.

TUNING +/- buttons

Scans all the available radio stations.

PRESET TUNING +/- buttons

Scans all preset stations.

FM MODE button

If "STEREO" flashes in the display and the FM stereo reception is poor, press this button. You will not have the stereo effect but the sound is improved.

FM/AM button

Selects the FM or AM band.

MEMORY button

Press to memorize a preset station.

- 14** **CURSOR MODE button**

Press this button repeatedly to select any of the following three cursor modes. The indicator for the selected cursor mode lights up to the left of the display window. The indicator turns off when you press the SET UP button.

When the cursor mode is	You can
SURROUND	Change the delay time, effect level, and the volume of the rear and center speakers (page 27)
BASS/TREBLE	Adjust the tone (bass/treble) for the front speakers (page 27). Press the TONE ON/OFF button to activate the tone effect.
INDEX	Enter an index name for preset stations and program sources (page 34)

- 15** **Cursor buttons (▲▼/◀▶)**

After pressing the CURSOR MODE or SET UP button, use these buttons to make specific settings (see pages 16, 27, and 34 to 36).

- 16** **SET UP button**

Press this button repeatedly to select any of the following three indications. The selected indication appears in the display and you will be able to make various settings using the cursor buttons.

When you've displayed	You can
CTR MODE	Select any one of the four center modes (page 16)
DSPL SET UP	Set the display at any of four levels of brightness and display operating status of the component connected to the S-LINK CONTROL A1 jack (page 36)
REAR GAIN	Increase the range of rear speakers by 5 dB (page 36)

Enjoying Surround Sound

This chapter describes how to set up the receiver to enjoy surround sound. You can enjoy the Dolby Surround-encoded software using this receiver.

You can take advantage of surround sound simply by selecting one of the pre-programmed "sound fields" that your receiver provides. You can enjoy the sound of a movie theater or concert hall in your own home. You can even customize a sound field by adjusting its parameters.

Sound fields are classified into two genres.

One genre is "CINEMA." The CINEMA-genre sound fields are designed for enjoying movies recorded on videos or laser discs. Six sound fields are included in the CINEMA genre and they are grouped into two types. PRO LOGIC sound field can be used to reproduce plain surround sound. When you select the PRO LOGIC sound field, the receiver decodes the software that is encoded using the Dolby Pro Logic system to obtain surround sound. The surround sound is reproduced in the exact way that the sound engineer of the software intended. Other sound fields in the CINEMA genre are designed to add more reverberation effects by incorporating Digital Cinema Sound technology. When you select these sound fields, the receiver adds the reflection and reverberation effects that are typical in movie theaters to the decoded Dolby Pro Logic Surround sound. You can enjoy the sound that you would experience in the movie theater.

Another genre is "MUSIC." When a sound field in this genre is selected, the receiver adds the reverberation to the normal 2-channel stereo sound. You can apply these sound fields when playing a CD or watching TV programs to obtain the surround effects of concert hall or a stadium.

To enjoy Dolby Pro Logic Surround sound fully, do the procedure on "Dolby Surround Setup" starting from page 15 to select the center mode and adjust the speaker volume.

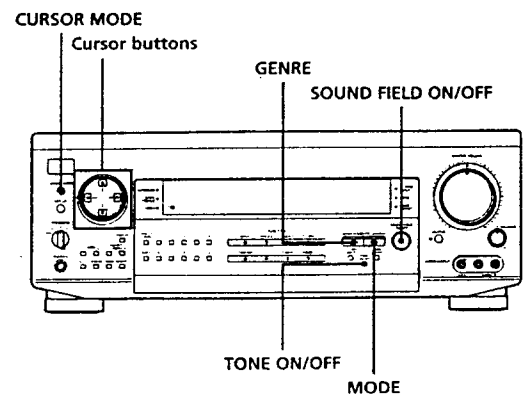

Brief descriptions of buttons used to enjoy surround sound

CURSOR MODE button: Press repeatedly to light up the SURROUND indicator or BASS/TREBLE indicator to customize a sound field.

Cursor buttons (^/~/</>): After pressing the CURSOR MODE button or SET UP button, use these buttons to make the actual setting.

GENRE button: Press to select the sound field group (genre) that you want.

SOUND FIELD ON/OFF button: Turns the sound field on or off.

MODE button: Press to select the sound field from the group you selected.

TONE ON/OFF button: Turns the tone effect on or off.

Selecting a Sound Field

You can enjoy surround sound simply by selecting one of the pre-programmed sound fields according to the program you want to listen to.

1 Press SOUND FIELD ON/OFF to turn on the sound field.

The current sound field is indicated in the display.

2 Press GENRE repeatedly to select the sound field group (genre), then press MODE repeatedly to select the sound field you want.

See the table on page 26 for information on each sound field.

 **The receiver memorizes the last sound field selected for each program source (Sound Field Link)**

Whenever you select a program source, the sound field that was last applied is automatically applied again. For example, if you listen to CD with STADIUM as the sound field, change to different program source, then return to CD, STADIUM will be applied again. In the case of the tuner, the sound fields for AM or FM band and for all the preset stations are memorized separately.

 **You can identify Dolby Surround-encoded software by looking at the packaging**

Some videos and laser discs, however, may be encoded with Dolby Surround sound even if it's not indicated on the package.

Notes

- When using sound fields, do not select both speakers (A+B) with the SPEAKERS selector.
- Sound fields are turned off whenever the program source connected to the 5.1 INPUT jacks is selected.

Selecting a Sound Field

Description of sound fields

GENRE (type)	MODE (sound field)	Effects
CINEMA	PRO LOGIC	Decodes programs processed with Dolby Pro Logic Surround
	C(inema) STUDIO A	Reproduces the sound characteristics of a movie theater. Good for watching standard movies.
	C(inema) STUDIO B	Reproduces the sound characteristics of a movie theater. Great for SFX or action movies with lots of sound effects.
	C(inema) STUDIO C	Reproduces the sound characteristics of a theater. Ideal for musicals and classical music concerts.
	N(ight) THEATER	Adjusts the tone for watching a movie at low volume at nighttime
	MONO MOVIE	Creates a theater-like environment when watching movies with monaural soundtracks

Enjoying Surround Sound

GENRE (type)	MODE (sound field)	Effects
MUSIC	HALL	Reproduces the acoustics of a rectangular concert hall. Ideal for soft acoustic sounds.
	JAZZ CLUB	Reproduces the acoustics of a jazz club
	DISCO*	Reproduces the acoustics of a discotheque
	CHURCH*	Reproduces the acoustics of a stone church
	LIVE HOUSE	Reproduces the acoustics of a 300-seat live house
	ARENA*	Reproduces the acoustics of a 1,000-seat concert hall. Great for rock or pop music.
	STADIUM	Reproduces the feeling of a large open-air stadium. Great for sporting events or electric sounds.
	GAME	Obtains maximum audio impact from video game software. Be sure to set the game machine to stereo mode for game software with stereo sound capability.

* STR-DE625 only

Customizing Sound Fields

By adjusting some of the sound parameters, you can customize sound fields to suit your particular listening situation.

Once you customize a sound field, the changes are stored in memory indefinitely (unless the receiver is unplugged for about one week). You can change a customized sound field any time by making new adjustments to the parameters.

See the table on page 28 for adjustable parameters for each sound field.

To get the most from Dolby Pro Logic Surround sound

Do the procedures "Selecting the center mode" and "Adjusting the speaker volume" on page 16 before you customize a sound field.

Changing the delay time (DELAY)

You can enhance the Dolby Pro Logic Surround sound even more by delaying the sound output from the rear speakers (delay time). You can select a delay time of 15, 20, or 30 ms. Set a short delay time when the rear speakers are located in a large room or far from where you are listening.

- 1 Start playing a program source encoded with Dolby Surround sound.
- 2 Press CURSOR MODE repeatedly until the SURROUND indicator lights up.
- 3 Use the cursor buttons (\wedge/\vee) to select "DELAY xxms."
The current delay time appears in the display.
- 4 Use the cursor buttons (\langle/\rangle) to change the delay time.

Changing the level of effect (EFFECT)

You can specify the amount of the surround effect (i.e., its overall presence) in six levels.

- 1 Press CURSOR MODE repeatedly until the SURROUND indicator lights up.
- 2 Use the cursor buttons (\wedge/\vee) to select "EFFECT."
The current effect level appears in the display.
- 3 Use the cursor buttons (\langle/\rangle) to change the effect level.

Adjusting the volume of the rear and center speakers (REAR/CENTER)

If you feel the volume of the rear or center speaker is inadequate (even after adjusting the speaker volume for Dolby Pro Logic Surround), do the procedure below to adjust the volume.

Note that the speaker volume adjustment is applied to all sound fields.

- 1 Press CURSOR MODE repeatedly until the SURROUND indicator lights up.
- 2 Use the cursor buttons (\wedge/\vee) to select "REAR xxdB" or "CENTER xxdB."
- 3 Use the cursor buttons (\langle/\rangle) to adjust the speaker volume.
You can select a volume level of -15 dB to +10 dB in 1-dB steps.

Adjusting the tone (BASS/TREBLE)

Adjust the tone (bass or treble) of the front speakers for optimum sound. You can adjust the tone for each separate sound field.

- 1 Press CURSOR MODE repeatedly until the BASS/TREBLE indicator lights up.
- 2 Use the cursor buttons (\wedge/\vee) to select "BASS xxdB" or "TREBLE xxdB."
- 3 Use the cursor buttons (\langle/\rangle) to adjust the tone level.
You can select a tone level of -10 dB to +10 dB in 2-dB steps.
- 4 Press TONE ON/OFF so that the TONE indicator lights up.

 You can turn off the tone adjustments without erasing them. The tone adjustments are stored separately for each sound field. Press the TONE ON/OFF button to turn the TONE indicator off.

Resetting customized sound fields to the factory settings

- 1 If the power is on, press I/⏻ to turn off the power.
- 2 Hold down SOUND FIELD ON/OFF and press I/⏻. "SUR CLEAR" appears in the display and all sound fields are reset at once.

Customizing Sound Fields

Adjustable parameters for each sound field

Sound field mode	GENRE	MODE	Parameters					Test tone output	
			DELAY	EFFECT	REAR ^{b)}	CENTER ^{c)}	TONE		
Off	—	—					●	From the front speakers	
On	CINEMA	PRO LOGIC	●		●	●	●	Depends on center mode (see page 16)	
		C STUDIO A		●	●	●	●		
		C STUDIO B		●	●	●	●		
		C STUDIO C		●	●	●	●		
		N THEATER		●	●		●		From the front and the rear speakers alternately
		MONO MOVIE		●	●		●		
	MUSIC	HALL		●	●		●		
		JAZZ CLUB		●	●		●		
		DISCO ^{a)}		●	●		●		
		CHURCH ^{a)}		●	●		●		
		LIVE HOUSE		●	●		●		
		ARENA ^{a)}		●	●		●		
		STADIUM		●	●		●		
		GAME		●	●		●		

a) STR-DE625 only

b) Adjustable only when the center mode is set to PHANTOM, NORMAL, or WIDE (see page 16).

c) Adjustable only when the center mode is set to 3CH LOGIC, NORMAL, or WIDE (see page 16).

 Test tone output when the component connected to the 5.1/ DVD INPUT jacks is selected

The test tone is successively output from the speakers in the following order: front (L), center, front (R), rear (R), rear (L). The volume level of the center and rear speakers cannot be adjusted at this time.

Note

To adjust the speaker volume using a test tone as described on page 16, select the PRO LOGIC sound field. The test tone output in all other sound fields is used for verifying whether there is output from speakers or not.

Receiving Broadcasts

This chapter describes how to receive FM or AM broadcasts and how to preset selected stations.

You can tune in stations on this receiver in the following ways:

Direct Tuning

You can enter a frequency of the station you want directly by using the numeric buttons (see page 30).

Automatic Tuning

If you don't know the frequency of the station you want, you can let the receiver scan all available stations in your area (see page 31).

Preset Tuning

After tuning in stations using Direct Tuning or Automatic Tuning, you can preset them in the receiver (see page 31). Then you can tune in any of the stations directly by entering its 2-character code (see page 32). You can preset up to 30 stations (FM and AM). The receiver will also scan all the stations that you have preset (see page 32).

Before you begin, make sure you have:

- Connected an FM and AM antenna to the receiver (see page 5).
- Selected the appropriate speaker system (see page 21).

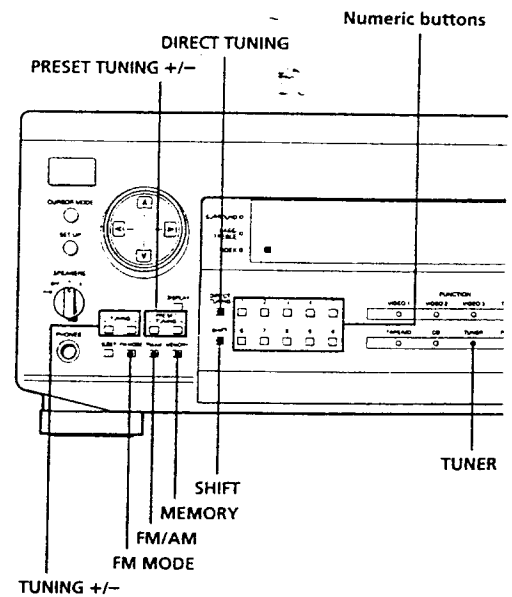

Brief descriptions of buttons used to receive broadcasts

PRESET TUNING +/-: Press to scan all preset radio stations.

DIRECT TUNING: Press this button to enter a frequency directly using the numeric buttons.

Numeric buttons: Press to enter a numeric value when inputting the frequency directly, presetting radio stations, or tuning to preset stations.

TUNING +/-: Press to scan all available radio stations.

FM MODE: If "STEREO" flashes in the display and the FM stereo reception is poor, press this button to improve the sound. You will not be able to enjoy stereo effect but the sound will be less distorted.

Note

If "STEREO" does not appear at all even when the FM broadcast is received normally, press this button to turn on the "STEREO" indication.

FM/AM: Press to select the FM or AM band.

MEMORY: Uses for memorizing preset stations.

SHIFT: Press to select a memory page (A, B, or C) for presetting radio stations or tuning to preset stations.

TUNER: Selects the tuner.

Direct Tuning

For details on the buttons used in this section, see "Brief descriptions of buttons used to receive broadcasts" on this page.

- 1 Press **TUNER** to light the button up.
The last received station is tuned in.
- 2 Press **FM/AM** to select the FM or AM band.
- 3 Press **DIRECT TUNING**.
- 4 Press the numeric buttons to enter the frequency.

Example 1: FM 102.50 MHz

$\overset{1}{\square} + \overset{0}{\square} + \overset{2}{\square} + \overset{5}{\square} + \overset{0}{\square}$

Example 2: AM 1350 kHz

(You don't have to enter the last "0.")

$\overset{1}{\square} + \overset{3}{\square} + \overset{5}{\square}$

If you cannot tune in a station and the entered numbers flash

Make sure you've entered the right frequency. If not, repeat Steps 3 and 4.

If the entered numbers still flash, the frequency is not used in your area.

- 5 If you've tuned in an AM station, adjust the direction of the AM loop antenna for optimum reception.
- 6 Repeat Steps 2 to 5 to receive another station.

To watch an FM simulcast TV program

Tune in the simulcast program on both the TV (or VCR) and the receiver.

If you try to enter a frequency that is too precise for the tuning scale

The entered value is automatically rounded up or down.

Tuning scale for direct tuning is:

FM: 50 kHz

AM: 10 kHz (USA and Canada only; to change to 9 kHz, see page 40.)

9 kHz (Singapore, Malaysia, and Australia only)

9 kHz (all countries except USA, Canada, Singapore,

Malaysia, and Australia; to change to 10 kHz, see page 40.)

Automatic Tuning

For details on the buttons used in this section, see "Brief descriptions of buttons used to receive broadcasts" on page 30.

- 1 Press **TUNER** to light the button up.
The last received station is tuned in.
- 2 Press **FM/AM** to select the FM or AM band.
- 3 Press **TUNING +** or **TUNING -**.
Press the + button to scan from low to high; press the - button to scan from high to low.

When the receiver reaches either end of the band

Scanning is repeated in the same direction.

The receiver stops scanning whenever a station is received.

- 4 To continue scanning, press **TUNING +** or **TUNING -** again.

Preset Tuning

For details on the buttons used in this section, see "Brief descriptions of buttons used to receive broadcasts" on page 30.

Before you can tune in a preset station, first do the procedure "Presetting radio stations" below.

Presetting radio stations

- 1 Press **TUNER** to light the button up.
The last received station is tuned in.
- 2 Tune in the station that you want to preset using **Direct Tuning** (page 30), or **Automatic Tuning** (this page).
- 3 Press **MEMORY**.
"MEMORY" appears in the display for a few seconds. Do Steps 4 and 5 before "MEMORY" goes out.
- 4 Press **SHIFT** to select a memory page (A, B or C).
Each time you press **SHIFT**, the letter "A," "B" or "C" appears in the display.
- 5 Select a preset number by pressing it (0 to 9).
If "MEMORY" goes out before you press the preset number, start again from Step 3.
- 6 Repeat Steps 2 to 5 to preset another station.

To change a preset number to another station

Do Steps 1 to 5 to preset the new station to the number.

Note

If the AC power cord is disconnected for about one week, all the preset stations will be cleared from the receiver's memory, and you will have to preset the stations again.

Preset Tuning

Tuning to preset stations

- 1 Press TUNER to light the button up.
The last received station is tuned in.
- 2 Press SHIFT to select a memory page (A, B or C),
then press the preset number of the station you
want.

Scanning preset stations

- 1 Press TUNER to light the button up.
The last received station is tuned in.
- 2 Press PRESET TUNING + or PRESET TUNING -
repeatedly to select the preset station you want.
Each time you press the button, the receiver tunes in
one preset station at a time, in the corresponding order
and direction as follows:

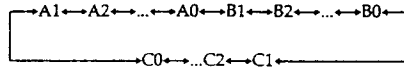

Other Operations

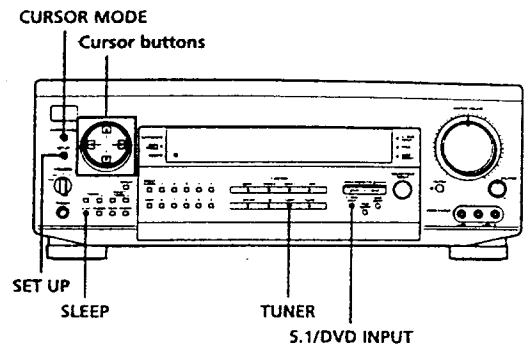

Brief descriptions of buttons that appear in this chapter

CURSOR MODE button: Used to light up the INDEX indicator to index preset stations or program sources.

Cursor buttons (▲▼◀▶): After pressing the SET UP button or CURSOR MODE button, use these buttons to make the actual setting.

SET UP button: Used to display "DIMMER," "CTRL.A1," or "REAR GAIN" in order to make respective adjustment.

SLEEP button: Used to set the sleep timer.

TUNER button: Press to select the tuner.

5.1/DVD INPUT button: Press to select the component connected to the 5.1/DVD INPUT jacks.

Indexing Preset Stations and Program Sources

You can enter a name of up to 8 characters for preset stations (station index) and program sources. These index names (for example, "VHS") appear in the receiver's display when a station or program source is selected. Note that no more than one name can be entered for each preset station or program source.

This function is useful for distinguishing components of the same kind. For example, two VCRs can be specified as "VHS" and "8MM," respectively. It is also handy for identifying components connected to jacks meant for another type of component, for example, a second CD player connected to the TAPE/MD jacks.

1 To index a preset station

Press TUNER.

The last station you received is tuned in.

To index a program source

Select the program source (component) to be named, then go to Step 3.

2 Tune in the preset station you want to create an index name for.

If you are not familiar with how to tune in preset stations, see "Tuning to preset stations" on page 32.

3 Press CURSOR MODE repeatedly until the INDEX indicator lights up.

4 Create an index name by using the cursor buttons as follows:

Press \wedge or \vee to select a character, then press $\>$ to move the cursor to the next position.

The index name is stored automatically.

To insert a space

Press \wedge or \vee until a blank space appears in the display (the space character is between "J" and "A").

If you've made a mistake

Press \leftarrow or \rightarrow repeatedly until the character to be changed flashes, then select the right character.

To assign index names to other stations

Repeat Steps 2 to 4.

Recording

Your receiver makes it easy to record to and from the components connected to it. You don't have to connect the playback and recording components directly to each other: once you select a program source on the receiver, you can record and edit as you normally would using the controls on each component.

Before you begin, make sure you've connected all components properly.

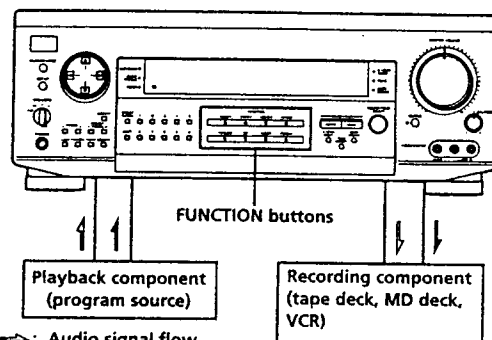

Recording on an audio tape or MiniDisc

You can record on a cassette tape or MiniDisc using the receiver. See the instruction manual of your cassette deck or MD deck if you need help.

- 1 Select the component to be recorded.
- 2 Prepare the component for playing.
For example, insert a CD into the CD player.
- 3 Insert a blank tape or MD into the recording deck and adjust the recording level, if necessary.
- 4 Start recording on the recording deck, then start playback on the playback component.

Notes

- You cannot record an analog audio signal from a component connected to the 5.1/DVD INPUT jacks.
- Sound adjustments do not affect the signal output from the TAPE/MD REC OUT jacks.

Recording on a video tape

You can record from a VCR, a TV, or an LD player using the receiver. You can also add audio from a variety of audio sources when editing a video tape. See your VCR or LD player's instruction manual if you need help.

- 1 Select the program source to be recorded.
- 2 Prepare the component for playing.
For example, insert the laser disc you want to record into the LD player.
- 3 Insert a blank video tape into the VCR for recording.
- 4 Start recording on the recording VCR, then start playing the video tape or laser disc you want to record.

 You can record the sound from any audio source onto a video tape while copying from a video tape or laser disc. Locate the point where you want to start recording from another audio source, select the program source, then start playback. The audio from that source will be recorded onto the audio track of the video tape instead of the audio from the original medium.

To resume audio recording from the original medium, select the video source again.

Notes

- You cannot record the audio from a program source connected to the 5.1/DVD INPUT jacks.
- Sound adjustments do not affect the signal output from the TAPE/MD REC OUT jacks.

Using the Sleep Timer

You can set the receiver to turn off automatically at a specified time.

Press SLEEP while the power is on.

Each time you press SLEEP, the time changes as shown below.

→ 2-00-00 → 1-30-00 → 1-00-00 → 0-30-00 → OFF

The display dims after you have specified the time.

 You can freely specify the time. Press SLEEP first, then specify the time you want using the cursor buttons (▲ or ▼). The sleep time changes in 1 minute intervals. You can specify up to 5 hours.

 You can check the time remaining before the receiver turns off.

Press SLEEP. The remaining time appears in the display.

Adjustments Using the SET UP Button

The SET UP button allows you to make following adjustments.

Adjusting the brightness of the display

- 1 Press SET UP repeatedly until "DSPL SET UP" appears in the display.
- 2 Press the cursor buttons (\wedge/\vee) to select "DIMMER."
- 3 Press the cursor buttons ($</>$) to select the brightness level.
You can select any of four brightness levels.

Increasing the output level of the rear speakers by 5 dB

- 1 Press SET UP repeatedly until "REAR GAIN" appears in the display.
- 2 Press the cursor buttons ($</>$) to select "GAIN UP."

To restore the normal output level

Repeat the procedure above, selecting "GAIN NORM" in Step 2.

Additional Information

Troubleshooting

If you experience any of the following difficulties while using the receiver, use this troubleshooting guide to help you remedy the problem. Should any problem persist, consult your nearest Sony dealer.

There's no sound or only a very low-level sound is heard.

- Check that the speakers and components are connected securely.
- Make sure that you've selected the correct component on the receiver.
- Make sure that you've set the SPEAKERS selector correctly (see page 21).
- Press the MUTING button to turn off the indicator to the left of the button.
- The protective device on the receiver has been activated because of a short circuit. Turn off the receiver, eliminate the short-circuit problem and turn on the power again.

No sound is heard from the center speaker.

- Select a sound field in the CINEMA genre (see page 26).
- If the PHANTOM center mode is selected, there is no center speaker output. Select the appropriate center mode (see page 16).
- Adjust the speaker volume appropriately (see page 16).
- After taking all the measures above, adjust the speaker volume with a test tone (see page 16) and verify that test tone is output from the center speaker.

No sound or only a very low-level sound is heard from the rear speakers.

- If the 3CH LOGIC center mode is selected, there is no rear speaker output. Select the appropriate center mode (see page 16).
- Adjust the speaker volume appropriately (see page 16).
- In normal two-channel stereo output, there is no rear speaker output. Make sure the sound field function is on.
- After taking all the measures above, adjust the speaker volume with a test tone (see page 16) and verify that test tone is output from the rear speakers.

Troubleshooting

The left and right sounds are unbalanced or reversed.

- Check that the speakers and components are connected correctly and securely.
- Adjust the BALANCE control.

Severe hum or noise is heard.

- Check that the speakers and components are connected securely.
- Check that the connecting cords are away from a transformer or motor, and at least 10 feet (3 meters) away from a TV set or fluorescent light.
- Move your TV away from the audio components.
- Make sure you've grounded SIGNAL GND terminal.
- The plugs and jacks are dirty. Wipe them with a cloth slightly moistened with alcohol.

Recording cannot be done.

- Check that the components are connected correctly.
- Select the source component with a FUNCTION button.
- You cannot record audio from a program source connected to the 5.1/DVD INPUT jacks.

Radio stations cannot be tuned in.

- Check that the antennas are connected securely. Adjust the antennas and connect an external antenna if necessary.
- The signal strength of the stations is too weak (when tuning in with automatic tuning). Use direct tuning.
- Make sure you set the tuning interval correctly (when tuning in AM stations with direct tuning) (see pages 30 and 40).
- No stations have been preset or the preset stations have been cleared (when tuning by scanning preset stations). Preset the stations (see page 31).
- Press the DISPLAY button so that the frequency appears in the display.

The surround effect cannot be obtained.

- Turn on the sound field function.
- Make sure that the SPEAKERS selector is set to A or B when you use two sets of front speakers.

No picture or an unclear picture appears on the TV screen or monitor.

- Select the appropriate function on the receiver.
- Press the TV/VIDEO button on the supplied remote to set your TV to the appropriate input mode.
- Move your TV away from the audio components.

The remote does not function.

- Point the remote at the remote sensor on the receiver.
- Remove any obstacles in the path between the remote and the receiver.
- Replace both batteries in the remote with new ones, if they are weak.
- Make sure you select the correct function on the remote.
- Pressing the TV CONTROL button sets the remote to operate the TV only. If this mode is on, press one of the FUNCTION buttons on the receiver or a function button on the remote before operating the receiver or another component.

Reference pages for clearing the receiver's memory

To clear	See page
All the contents of memory	17
Customized sound fields	27

Specifications

AUDIO POWER SPECIFICATIONS

POWER OUTPUT AND TOTAL HARMONIC DISTORTION:

With 8 ohm loads, both channels driven, from 20 - 20,000 Hz; rated 100 watts per channel minimum RMS power, with no more than 0.09% total harmonic distortion from 250 milliwatts to rated output.

Amplifier section

POWER OUTPUT

Stereo mode (8 ohms 20 Hz - 20 kHz, THD 0.09%) 100 W + 100 W

Surround mode

(8 ohms at 1 kHz, THD 0.8%)
 Front: 100 W / ch
 Center^{a)}: 100 W
 Rear^{a)}: 100 W / ch

a) Depending on the sound field settings and the source, there may be no sound output.

5.1/DVD mode (8 ohms at 1 kHz, THD 0.8%)

Front: 100 W / ch
 Center: 100 W
 Rear: 100 W / ch

Dynamic power output

155 W + 155 W, 8 ohms
 220 W + 220 W, 4 ohms

Frequency response

PHONO: RIAA
 equalization curve
 ±0.5 dB
CD, TAPE/MD, VIDEO
 1, 2:
 10 Hz - 50 kHz +0.5/
 -2 dB (with sound field, tone, and bass booster bypassed)

Inputs

PHONO:
 Sensitivity: 1.5 mV
 Impedance: 50 kilohms
 S/N^{b)}: 75 dB (A, 2.5 mV^{c)})

CD:

Sensitivity: 150 mV
 Impedance:
 50 kilohms
 S/N^{b)}: 82 dB (A, 150 mV^{c)})

TAPE/MD, VIDEO 1, 2, VIDEO 3 (STR-DE625), VIDEO (STR-DE525), TV/DBS (TV/LD):
 Sensitivity: 150 mV
 Impedance:
 50 kilohms
 S/N^{b)}: 82 dB (A, 150 mV^{c)})

5.1/DVD INPUT

Sensitivity: 150 mV
 Impedance:
 50 kilohms
 S/N^{b)}: 82 dB (A, 150 mV^{c)})

b) 78' IHF

c) Weighted network, input level

Outputs

AUDIO OUT:

Voltage: 150 mV
 Impedance:
 10 kilohms
WOOFER:
 Voltage: 2 V
 Impedance:
 1 kilohm
PHONES:
 Accepts low- and high-impedance headphones

BASS BOOST +10 dB at 70 Hz

TONE ±10 dB at 100 Hz and 10 kHz

FM tuner section

Tuning range 87.5 - 108.0 MHz

Antenna terminals

75 ohms, unbalanced

Sensitivity Mono: 18.3 dBf, 4.5 μV
 Stereo: 38.3 dBf, 45 μV

Usable sensitivity

11.2 dBf, 2 μV (IHF)

S/N

Mono: 76 dB
 Stereo: 70 dB

Harmonic distortion at 1 kHz

Mono: 0.3%
 Stereo: 0.5%

Separation

45 dB at 1 kHz

Frequency response

30 Hz - 15 kHz +0.5/
 -2 dB

Selectivity

60 dB at 400 kHz

© 1998 Philips North America Consumer Electronics

Specifications

AM tuner section

Tuning range	With 10-kHz tuning scale: 530 - 1710 kHz (USA and Canada only ^d) 530 - 1610 kHz (all other countries except Singapore, Malaysia, and Australia) With 9-kHz tuning scale: 531 - 1710 kHz (USA and Canada only) 531 - 1602 kHz (all other countries ^d)
Antenna	Loop antenna
Usable sensitivity	50 dB/m (at 1,000 kHz or 999 kHz)
S/N	54 dB (at 50 mV/m)
Harmonic distortion	0.5 % (50 mV/m, 400 kHz)
Selectivity	At 10 kHz: 40 dB At 9 kHz: 35 dB

d) You can change the AM tuning scale to 9 kHz (USA and Canada only) or to 10 kHz (all countries except USA, Canada, Singapore, Malaysia, and Australia). After tuning in any AM station, turn off the receiver. Press down the TUNING + or PRESET TUNING + button and press the V/C button. All preset stations will be reset to their factory settings when you change the tuning scale. To reset the scale to 10 kHz (or 9 kHz), repeat the procedure.

Video section

Inputs	1 Vp-p 75 ohms
Outputs	1 Vp-p 75 ohms

General

System	Tuner section: PLL quartz-locked digital synthesizer system Preamplifier section: Low-noise NF type equalizer Power amplifier section: Pure-complementary SEPP
--------	---

Power requirements

USA and Canada:	120 V AC, 60 Hz
Australia:	240 V AC, 50 Hz
Singapore and Malaysia:	230 V AC, 50/60 Hz
All other countries:	120/240/220 V AC selectable, 50/60 Hz

Power consumption

Canada:	400 VA
All other countries:	250 W

AC outlets	Australia, Singapore, and Malaysia: 1 switched, maximum 100 W All other countries: 2 switched, total 120 W
------------	---

Dimensions	430 × 157.5 × 370 mm (17 × 6 ¹ / ₄ × 14 ⁵ / ₈ inches) including projecting parts and controls
------------	---

Mass (approx.)

	9.1 kg (20 lb 1 oz)
--	---------------------

Supplied accessories See page 4.

Design and specifications are subject to change without notice.

Glossary

Surround sound

Sound that consists of three elements: direct sound, early reflected sound (early reflections) and reverberative sound (reverberation). The acoustics of the surrounding space affect the way these three sound elements are heard. Surround sound combines these sound elements in such a way that you actually can sense the size of the venue, as well as its type.

• Types of sound

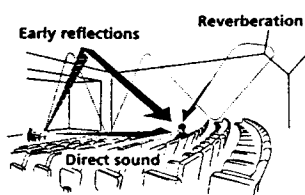

• Transition of sound from rear speakers

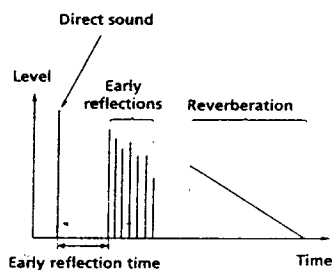

Dolby Pro Logic Surround

As one method of decoding Dolby Surround, Dolby Pro Logic Surround produces four channels from two-channel sound. Compared with the former Dolby Surround system, Dolby Pro Logic Surround reproduces left-to-right panning more naturally and localizes sounds more precisely. To take full advantage of Dolby Pro Logic Surround, you should have one pair of rear speakers and a center speaker. The rear speakers output monaural sound.

Dolby Digital (AC-3)

This sound format for movie theaters is more advanced than Dolby Pro Logic Surround. In this format, the rear speakers output stereo sound with an expanded frequency range and a subwoofer channel for deep bass is independently provided. This format is also called "5.1" because the subwoofer channel is counted as 0.1 channel (since it functions only when a deep bass effect is needed). All six channels in this format are recorded separately to realize superior channel separation. Furthermore, since all the signals are processed digitally, less signal degradation occurs. The name "AC-3" comes from the fact that it is the third audio coding method to be developed by the Dolby Laboratories Licensing Corporation.

Digital Cinema Sound

This is the generic name of the surround sound produced by digital signal processing technology developed by Sony. Unlike previous surround sound fields mainly directed at the reproduction of music, Digital Cinema Sound is designed specifically for the enjoyment of movies.

5.1/DVD INPUT jacks

These jacks are used to input decoded Dolby Digital (AC-3) audio signals, allowing you to enjoy 5.1 channel surround sound. Use these jacks to connect a Dolby Digital (AC-3) decoder or a DVD player with a built-in AC-3 decoder.

Tables of Settings Made Using the CURSOR MODE and SET UP Buttons

A variety of settings can be made using the CURSOR MODE and SET UP buttons, in conjunction with the cursor buttons. These settings are shown in the following tables.

Press CURSOR MODE repeatedly to light up	Press \wedge or \vee to select	Then $<$ or $>$ to select	See page
SURROUND indicator	DELAY	15, 20, or 30 ms	27
	EFFECT	among six levels of amount of effect	
	REAR LEVEL	between -15 dB to +10 dB (in 1-dB steps)	
	CENTER LEVEL		
BASS/TREBLE indicator	BASS LEVEL	between -10 dB to +10 dB (in 2-dB steps)	
	TREBLE LEVEL		
INDEX indicator	a character	cursor position	34

Press SET UP repeatedly to display	Press \wedge or \vee to select	Then $<$ or $>$ to select	See page
CTR MODE	—	PHANTOM, 3CH LOGIC, NORMAL, or WIDE	16
DSPL SET UP	DIMMER	among four levels of brightness	36
	CTRL A1 (USA, Canada, and Australia only)	ON or OFF	
REAR GAIN	—	GAIN UP or GAIN NORM	

Additional Information

Index

A

- Adjusting
 - brightness of the display 36
 - rear and center speaker volume 27
 - speaker volume 16
 - tone 27
- Automatic tuning 31

B

- Basic amplifier operations 20-22
- Battery 4

C

- Center mode 16
- Changing
 - delay time 27
 - display 22
 - effect level 27
- Checking the connections 17
- Clearing receiver's memory 17
- Connecting. *See Hookups*

D

- Delay time 27
- Digital Cinema Sound 41
- Direct tuning 30
- Dolby Digital (AC-3) 41
- Dolby Pro Logic Surround 15, 16, 24, 26, 27, 41
- Dolby Surround setup 15, 16
- Dubbing. *See Recording*

E, F, G

- Editing. *See Recording*
- Effect level 27

H

- Hookups
 - AC power cord 12
 - antennas 5
 - audio components 6
 - CONTROL A1 11
 - CONTROL S 11
 - 5.1 input 9
 - speaker system 14
 - video components 7, 8

I, J, K

- Indexing
 - preset stations 34
 - program sources 34

L, M, N, O

- Labeling. *See Indexing*

P, Q

- Parameter 27, 28
- Preset tuning
 - how to 32
 - preset number 31
 - presetting stations 31
 - scanning preset stations 32

R

- Receiving broadcasts
 - by scanning stations. *See Automatic tuning*
 - directly. *See Direct tuning*
 - using preset stations. *See Preset tuning*
 - tuning scale 30, 40
- Recording
 - on an audio tape or MD 34
 - on a video tape 35

S

- Scanning
 - preset stations. *See Preset tuning*
 - radio stations. *See Automatic tuning*
- Selecting
 - center mode 16
 - component 20, 21
 - front speakers 21
 - sound field 25
- Sleep timer 35
- Sound field
 - adjustable parameters 28
 - customizing 27, 28
 - link 25
 - pre-programmed 24-26
 - resetting 27
 - selecting 25

Speakers

- adjusting rear and center speaker volume 27
- adjusting volume 16, 27
- connection 14
- impedance 15
- increasing rear speaker output level 36
- locating 15
- selecting center mode 16
- selecting front speakers 21
- Station index. *See Indexing*
- Supplied accessories 4
- Surround sound 15, 16, 24, 25, 41

T

- Test tone 16, 28
- Tone 27
- Tuning. *See Receiving broadcasts*

U, V, W, X, Y, Z

- Unpacking 4