

# IC Recorder

## Owner's Record

The model number is located at the rear panel and the serial number is located inside the battery compartment. Record the serial number in the space provided below. Refer to these numbers whenever you call upon your Sony dealer regarding this product.

Model No. ICD-P620 \_\_\_\_\_  
Serial No. \_\_\_\_\_

Operating Instructions

ICD-P620

**IC RECORDER**

Getting Started	_____
Basic Operations	_____
Various Recording Modes	_____
Playback/Erasing	_____
Editing Messages	_____
Utilizing the Menu Function	_____
Using the IC Recorder with Your Computer	_____
Troubleshooting	_____
Additional Information	_____

## For the customers in the United States

The following FCC statement applies only to the version of this model manufactured for sale in the USA. Other versions may not comply with FCC technical regulations.

## INFORMATION

This equipment has been tested and found to comply with the limits for a Class B digital device, pursuant to Part 15 of the FCC Rules. These limits are designed to provide reasonable protection against harmful interference in a residential installation. This equipment generates, uses and can radiate radio frequency energy and, if not installed and used in accordance with the instructions, may cause harmful interference to radio communications. However, there is no guarantee that interference will not occur in a particular installation. If this equipment does cause harmful interference to radio or television reception, which can be determined by turning the equipment off and on, the user is encouraged to try to correct the interference by one or more of the following measures:

- Reorient or relocate the receiving antenna.
- Increase the separation between the equipment and receiver.
- Connect the equipment into an outlet on a circuit different from that to which the receiver is connected.
- Consult the dealer or an experienced radio/TV technician for help.

You are cautioned that any changes or modifications not expressly approved in this manual could void your authority to operate this equipment.

If you have any questions about this product, you may call: Sony Customer Information Services Center 1-800-222-7669 or <http://www.sony.com/>

## Declaration of Conformity

Trade Name : SONY  
Model : ICD-P620  
Responsible Party : Sony Electronics Inc.  
Address : 16530 Via Esprillo, San Diego, CA 92127 USA  
Telephone Number : 858-942-2230

This device complies with part 15 of the FCC Rules. Operation is subject to the following two conditions: (1) This device may not cause harmful interference, and (2) this device must accept any interference received, including interference that may cause undesired operation.

## For the State of California, USA only

Perchlorate Material — special handling may apply, See [www.dtsc.ca.gov/hazardouswaste/perchlorate](http://www.dtsc.ca.gov/hazardouswaste/perchlorate)  
Perchlorate Material : Lithium battery contains perchlorate

## For customers in Europe

### Disposal of Old Electrical & Electronic Equipment (Applicable in the European Union and other European countries with separate collection systems)



This symbol on the product or on its packaging indicates that this product shall not be treated as household waste. Instead it shall be handed over to the applicable collection point for the recycling of electrical and electronic equipment. By ensuring this product is disposed of correctly, you will help prevent potential negative consequences for the environment and human health, which could otherwise be caused by inappropriate waste handling of this product. The recycling of materials will help to conserve natural resources. For more detailed information about recycling of this product, please contact your local Civic Office, your household waste disposal service or the shop where you purchased the product.

## **Disposal of waste batteries (applicable in the European Union and other European countries with separate collection systems)**



This symbol on the battery or on the packaging indicates that the battery provided with this product shall not be treated as household waste. By ensuring these batteries are disposed of correctly, you will help prevent

potentially negative consequences for the environment and human health which could otherwise be caused by inappropriate waste handling of the battery. The recycling of the materials will help to conserve natural resources.

In case of products that for safety, performance or data integrity reasons require a permanent connection with an incorporated battery, this battery should be replaced by qualified service staff only. To ensure that the battery will be treated properly, hand over the product at end-of-life to the applicable collection point for the recycling of electrical and electronic equipment.

For all other batteries, please view the section on how to remove the battery from the product safely. Hand the battery over to the applicable collection point for the recycling of waste batteries.

For more detailed information about recycling of this product or battery, please contact your local Civic Office, your household waste disposal service or the shop where you purchased the product.

## **Notice for the customers in the countries applying EU Directives**

The manufacturer of this product is Sony Corporation, 1-7-1 Konan, Minato-ku, Tokyo, Japan. The Authorized Representative for EMC and product safety is Sony Deutschland GmbH, Hedelfinger Strasse 61, 70327 Stuttgart, Germany. For any service or guarantee matters please refer to the addresses given in separate service or guarantee documents.

---

## **Notice for Users**

Program © 1999, 2000, 2001, 2002, 2003, 2004, 2005, 2006, 2007, 2008 Sony Corporation  
Documentation ©2008 Sony Corporation

All rights reserved. This manual or the software described herein, in whole or in part, may not be reproduced, translated or reduced to any machine readable form without prior written approval from Sony Corporation.

IN NO EVENT SHALL SONY CORPORATION BE LIABLE FOR ANY INCIDENTAL, CONSEQUENTIAL OR SPECIAL DAMAGES, WHETHER BASED ON TORT, CONTRACT, OR OTHERWISE, ARISING OUT OF OR IN CONNECTION WITH THIS MANUAL, THE SOFTWARE OR OTHER INFORMATION CONTAINED HEREIN OR THE USE THEREOF.

Sony Corporation reserves the right to make any modification to this manual or the information contained herein at any time without notice. The software described herein may also be governed by the terms of a separate user license agreement.

- This software is for Windows and cannot be used for Macintosh.
- The supplied connecting cable is for the IC recorder ICD-P620. You cannot connect other IC recorders.

---

# Table of Contents

Index to Parts and Controls.....	6
----------------------------------	---

---

## Getting Started

Step 1: Installing the Batteries .....	9
Replacing the batteries.....	10
Step 2: Setting the Clock.....	11

---

## Basic Operations

Recording Messages.....	13
Selecting the Folder.....	17
Starting Recording Automatically in Response to the Sound — Advanced VOR Function .....	17
Selecting the Microphone Sensitivity.....	18

---

## Various Recording Modes

Adding a Recording.....	19
Using an adding recording .....	19
Adding a recording to a previously recorded message.....	20

Recording with an External Microphone or from Other Equipment.....	21
--	----

---

## Playback/Erasing

Playing Back Messages.....	23
Playing back a message repeatedly — Repeat Play.....	25
Playing back all messages in a folder continuously — Continuous Play .....	25
Searching forward/backward during playback (Cue/Review).....	25
Locating quickly the point you wish to start playback (Easy Search).....	26
Playing Back a Message at a Desired Time with an Alarm .....	26
Erasing Messages.....	30
Erasing messages one by one .....	30
Erasing all messages in a folder...31	

---

## **Editing Messages**

Dividing a Message.....	32
Moving Messages to a Different Folder — Move Function.....	33

---

## **Utilizing the Menu Function**

Selecting the Display Mode.....	35
Turning off the Beep Sound .....	36
Changing the Recording Mode.....	36
Playing Back All Messages in a Folder Continuously .....	37
Turning off the Operation Indicator (LED).....	37

---

## **Using the IC Recorder with Your Computer**

Using the Supplied Digital Voice Editor Software.....	38
What you can do using the Digital Voice Editor software .....	38
System requirements.....	39
Installing the software.....	40
Connecting the IC recorder to your computer .....	44
Referring to the help files.....	45

---

## **Troubleshooting**

Troubleshooting.....	46
----------------------	----

---

## **Additional Information**

Precautions.....	52
Specifications.....	53

# Index to Parts and Controls

## Main unit

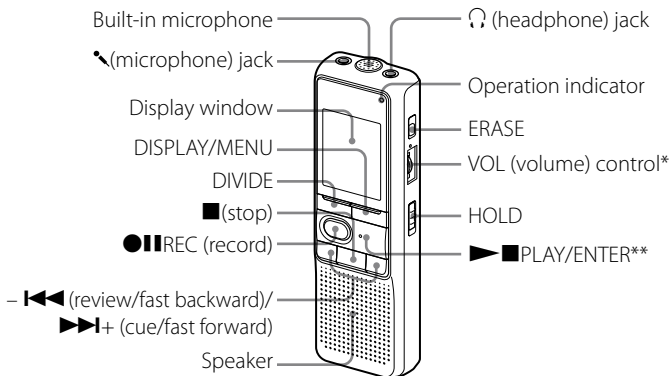

\* There is a tactile dot beside the control to show the direction to turn up the volume.

\*\* The button has a tactile dot.

## Preventing Accidental Operation

### — HOLD function

Slide the HOLD switch to ON. "HOLD" will flash three times, indicating that all the functions of the buttons are locked.

When the HOLD function is activated during stop, all the display will be turned off after "HOLD" flashes.

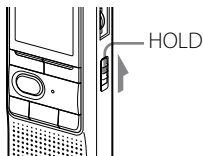

### To cancel the HOLD function

Slide the HOLD switch to OFF.

### Note

When the HOLD function is activated during recording, cancel the HOLD function first to stop recording.

### Tip

Even if the HOLD function is activated, you can stop the alarm playback. To stop the alarm or playback, press  (stop).

## Rear

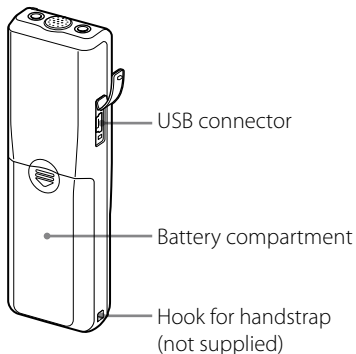

## Display window

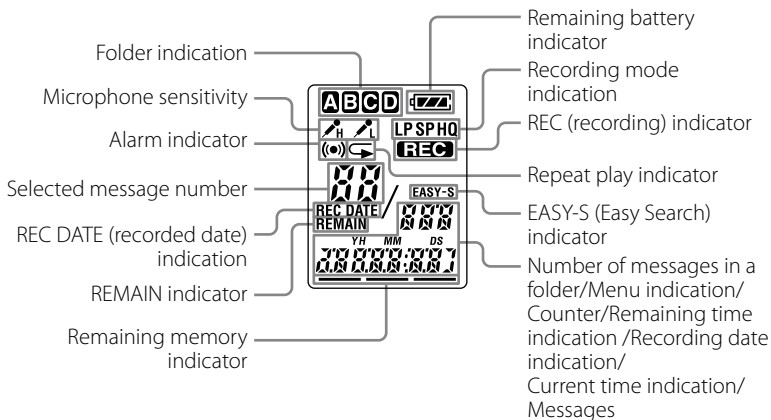



## Step 1: Installing the Batteries

- 1 Slide and lift the battery compartment lid.

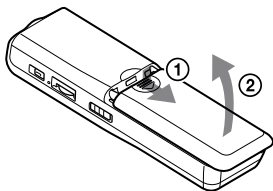

- 2 Insert two LR03 (size AAA) alkaline batteries with correct polarity, and close the lid.

Make sure to insert both of the batteries from their – ends.

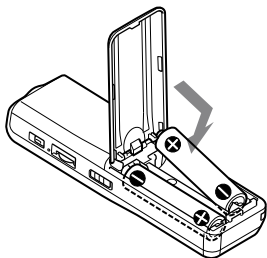

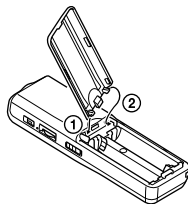

If the battery compartment lid is accidentally detached, attach it as illustrated.



Clock setting display appears when you insert batteries for the first time, or when you replace the batteries with new ones. Please refer to Steps 2 to 3 in “Step 2: Setting the Clock” to set the date and time.

## Replacing the batteries

The battery indicator in the display window shows the battery condition. When "  " flashes, replace the batteries with new ones.

When "  " flashes, the batteries are exhausted and the unit will stop operation.

### Battery life\* (With continuous use)

#### In the HQ mode

---

Recording:      Approx. 11 hr.

---

Playback\*\*:

---

#### In the SP and LP modes

---

Recording:      Approx. 22 hr.

---

Playback\*\*:

---

(hr.: hours)

\* Using Sony alkaline batteries LR03 (size AAA)

\*\*When playing back through the internal speaker with the medium volume level

The battery life may shorten depending on the operation of the unit.

## Notes

- Do not use manganese batteries for this unit.
- When you replace the batteries with new ones, the clock setting display appears. In this case, set the date and time again. The recorded messages and alarm setting, however, will remain.
- When replacing the batteries, be sure to replace both batteries with new ones.
- Do not charge dry batteries.
- When you are not going to use the unit for a long time, remove the batteries to prevent damage from battery leakage and corrosion.
- The unit is accessing data while "ACCESS" appears in the display window or the operation indicator flashes in orange. While accessing, do not remove the batteries. Doing so may damage the data.

## Step 2: Setting the Clock

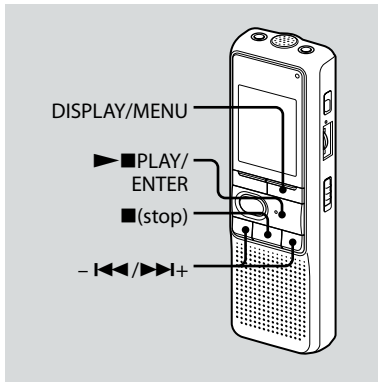

Clock setting display appears when you insert batteries for the first time, or when you replace the batteries with new ones. In this case, proceed from step 2.

### 1 Display the clock setting display.

- ① Press DISPLAY/MENU for more than 1 second until "MODE" appears in the display window.  
The unit enters the menu mode.
- ② Press - I◀◀ or ▶▶ I+ to display "SET DATE."
- ③ Press ▶ ■ PLAY/ENTER.  
The year digits will flash.

### 2 Set the date.

- ① Press - I◀◀ or ▶▶ I+ to select the digits of the year.
- ② Press ▶ ■ PLAY/ENTER.  
The month digits will flash.
- ③ Set the month and day in sequence, then press ▶ ■ PLAY/ENTER.  
The hour digits will flash.

#### Tip

To set the date to Year 2008, display "08Y."

### 3 Set the time.

- ① Press **←** or **→** to select the digits of the hour.
- ② Press **▶** **■** PLAY/ENTER.  
The minute digits will flash.
- ③ Set the minute.
- ④ Press **▶** **■** PLAY/ENTER at the time signal.  
The display will return to "SET DATE."
- ⑤ Press **■** (stop) to exit from the menu mode.  
If the unit is left unused for more than 3 seconds in the stop mode, the display will show the current time.

#### Tips

- This unit does not have a power on/off switch. The display is shown at all times.
- You can select the 12-hour display using the menu. To set the 12-hour display, select "12H" in the "HOUR" menu. In that case, "AM12:00" will appear in step 2-③.

## Recording Messages

### Display window

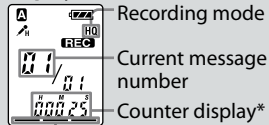

Remaining memory indicator

\* The display selected with the DISPLAY/MENU button appears.

Built-in microphone

Operation indicator (lights in red during recording.)

● REC

■ (stop)

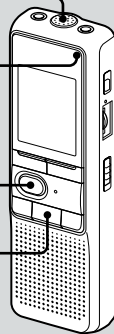

You can record up to 99 messages in each of the four folders (A, B, C, and D). Since a newly recorded message is automatically added behind the last recorded message, you can start recording quickly without searching for the end of the last recording.

### Note

Before making a long recording, be sure to insert new batteries and check the battery indicator.

### 1 Select the recording mode.

See “Changing the Recording Mode” on page 36.

### 2 Select the folder.

See “Selecting the Folder” on page 17.

### 3 Start recording.

- 1 Press ●■■REC.  
You do not need to keep pressing ●■■REC while recording.
- 2 Speak to the built-in microphone.

### 4 Stop recording.

Press ■(stop).

The unit stops at the beginning of the current recording.

If you do not change the folder after you stop recording, the next time you record you will record in the same folder.

## Other operations

To	Do this
pause recording*	Press ●■■REC. During recording pause, the operation indicator flashes in red and "PAUSE" flashes in the display window.
release pause and resume recording	Press ●■■REC. Recording resumes from that point. (To stop recording after pausing recording, press ■(stop).)

To	Do this
listen to the current recording	Press ■(stop) to stop recording, then press ►■PLAY/ENTER.
review the current recording instantly	Press ►■PLAY/ENTER during recording.
search backward during recording (Review)	Hold down - ◀◀ during recording or recording pause. Recording mode will be released, and reviewing of the current recording starts. If you release the button, playback starts from that point.
select the microphone sensitivity	You can select the microphone sensitivity using the menu. See "Selecting the Microphone Sensitivity." H (high): To record at meeting or in a quiet and/or spacious place. L (low): To record for dictation or in a noisy place.

- \* About one hour after you pause recording, recording pause is automatically released and the unit goes into the stop mode.

## Note on recording

Noise may be recorded if an object, such as your finger, etc., accidentally rubs or scratches the unit during recording.

## Maximum recording time

The maximum recording time of all the folders is as follows. You can record messages for the maximum recording time in a single folder.

HQ*	59 hr. 45 min.
SP**	159 hr. 20 min.
LP***	261 hr. 45 min.

(hr.: hours/min.: minutes)

- \* HQ: High quality recording mode (monaural sound)
- \*\* SP: Standard play recording mode (monaural sound)
- \*\*\* LP: Long play recording mode (monaural sound)

## Notes

- To record in better sound quality, select the HQ mode. For switching the recording mode, see “Changing the Recording Mode” on page 36.
- Before making a long recording, be sure to check the battery indicator.
- The maximum recording time and the number of messages you can make vary depending on the conditions of use.

- When you record messages in the mixture of HQ, SP and LP modes, the maximum recording time will be between those for the HQ and LP modes.
- Due to the limitation of the IC recording system, this unit records in the minimum recording unit of approx. 2 seconds at most, therefore the following symptoms may occur:
  - When a message is shorter than the minimum recording unit, it is still counted as approx. 2 seconds at most so the remaining recording time will decrease by more than the actual length of the message.
  - When the message is longer than the minimum recording unit, the remaining recording time will decrease by more than the actual length of the message if it cannot be divided by the minimum recording unit without a remainder.
  - The sum of the number on the counter (elapsed recording time) and the remaining recording time may be less than the unit’s maximum recording time.

## Remaining memory indication

During recording, the remaining memory indicator decreases one by one.

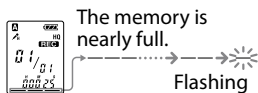

When the remaining time of recording reaches 5 minutes, the last one of the indication flashes.

If the remaining recording time display mode is selected, the remaining recording time display will also flash when the remaining time reaches 1 minute.

When the memory is full, recording automatically stops and "FULL" will flash in the display window with an alarm sound. To continue recording, first erase some of the messages.

## Notes

- If you press ●■■REC when the memory is full, "FULL" will flash with an alarm sound. Erase some of the messages before you start recording again.
- If you press ●■■REC after you have recorded 99 messages, "FULL" will flash with an alarm sound. Select another folder or erase some of the messages.



## Selecting the Folder

- 1 Press DISPLAY/MENU for more than 1 second until “MODE” appears in the display window.
- 2 Press **←** or **→** to select “FOLDER” and press **▶** **■**PLAY/ENTER.
- 3 Press **←** or **→** to select the folder you want and press **▶** **■**PLAY/ENTER.

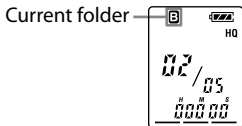

- 4 Press **■**(stop) to exit the menu mode.

## Starting Recording Automatically in Response to the Sound — Advanced VOR Function

When VOR (voice operated recording) is set to “ON” in the menu, recording starts when the recorder detects sound. (“VOR” is displayed in the display window.) Recording stops when no sound is heard. (“VOR PAUSE” flashes in the display window.)

### Note

VOR function is affected by the sound around you. Set the microphone sensitivity to “H (high)” or “L (low)” using the menu. If recording is not satisfactory after you have changed the microphone sensitivity, or for important recording, set VOR to “OFF.”

---

## Selecting the Microphone Sensitivity

- 1 Press DISPLAY/MENU for more than 1 second until "MODE" appears in the display window.
- 2 Press - I◀◀ or ▶▶I+ to select "SENS" and press ▶■PLAY/ENTER.
- 3 Press - I◀◀ or ▶▶I+ to select "H (high sensitivity)" or "L (low sensitivity)" and press ▶■PLAY/ENTER.
- 4 Press ■(stop) to exit the menu mode.

# Adding a Recording

## Using an adding recording

At a factory setting, you cannot add a recording not to erase the message by accidental operation. If you want to add a recording to a previously recorded message or add an overwrite recording, change the REC-OP setting in the procedures below.

**1 Press DISPLAY/MENU for more than 1 second until "MODE" appears in the display window.**

**2 Press - I◀◀ or ▶▶I+ to display "REC-OP" and press ▶■PLAY/ENTER.**

The adding recording window will be displayed.

**3 Press - I◀◀ or ▶▶I+ to select "ON" and press ▶■PLAY/ENTER.**

The setting is changed.

**4 Press - I◀◀ or ▶▶I+ to select "ADD" or "OVER" and press ▶■PLAY/ENTER.**

- ADD: adds a recording to a previously recorded message
- OVER: adds an overwrite recording.

**5 Press ■(stop) to exit the menu mode.**

## To prohibit to add a recording

In step 3, select "OFF" and press ▶■PLAY/ENTER.

## Adding a recording to a previously recorded message

You can add a recording to the message being played back.

### When “ADD” is selected in the menu

The added recording will be placed after the current message and counted as a part of the message.

During playback of Message 3

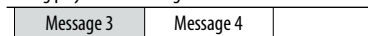

After adding a recording



### When “OVER” is selected in the menu

You can add an overwrite recording after the selected point in a recorded message. The part of the message after the selected point is deleted.

The starting point of an overwrite recording

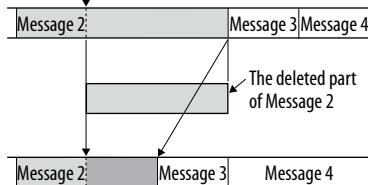

Added overwrite recording in Message 2

## 1 During playback, press and hold



The “REC” indication appears.

“ADD” or “OVER” will flash and the unit stops in the recording pause mode.

**2** While “ADD” or “OVER” flashes, press **●** **REC** again.

The operation indicator will light in red. An add or overwrite recording starts.

**3** Press **■**(stop) to stop the recording.

**Notes**

- You cannot add or overwrite a recording if the remaining memory is not long enough.
- The added or overwritten portion of a message will be recorded in the same recording mode (HQ, SP, or LP).

## Recording with an External Microphone or from Other Equipment

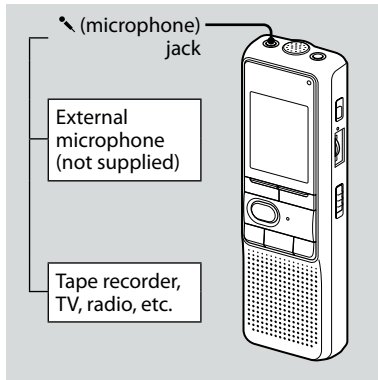

**1** Connect a plug-in-power type microphone or other equipment to the **⌘**(microphone) jack.

When you connect an external microphone, the built-in microphone is automatically cut off. When a plug in power type microphone is connected, power is automatically supplied to the microphone from the IC recorder.

## **2 Follow the steps in “Recording Messages” on page 13 to record messages.**

### **📌 Notes**

- Make sure that the plugs are connected securely.
- We recommend you make a trial recording to check the connections and volume control.
- When connecting equipment other than Sony's, refer to the instruction manual of the equipment.

## Playing Back Messages

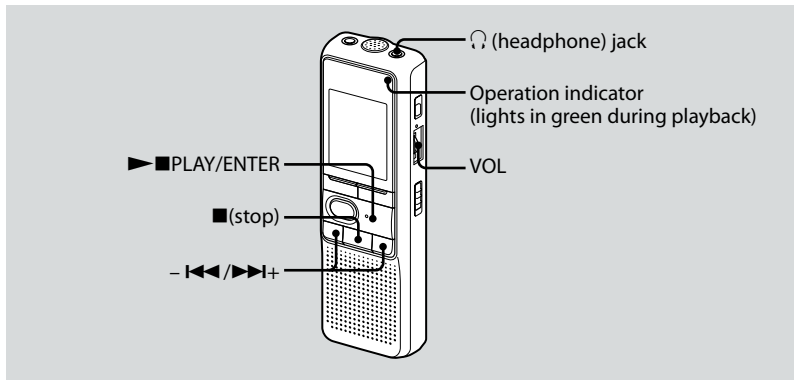

When playing back a previously recorded message, start from Step 1.

When playing back a message you have just finished recording, start from Step 3.

### 1 Select the folder.

See "Selecting the Folder" on page 17.

### 2 Select the message number.

Press - I◀◀ or ▶▶+ to display the desired message number.

- I◀◀: for smaller message number

▶▶+: for larger message number

### 3 Start playback.

- 1 Press **▶■**PLAY/ENTER.
- 2 Adjust the volume with the VOL control.

### 4 Stop playback.

Press **■**(stop).

After playing back one message, the unit stops at the beginning of the next message. When the continuous play function is set to "CONT ON" (page 37), the unit stops after playing all messages in a folder.

When the last message on a folder has been played back, the unit stops at the beginning of the last message.

### For private listening

Connect an ear receiver or headphones to the  (headphone) jack. The built-in speaker will be automatically disconnected. If noise is heard, wipe the headphones plug.

### Other operations

To	Do this
stop at the current position	Press <b>▶■</b> PLAY/ENTER or <b>■</b> (stop). To resume playback from that point, press <b>▶■</b> PLAY/ENTER again.
go back to the beginning of the current message	Press <b>- ◀◀</b> once.*
skip to the next message	Press <b>▶▶ +</b> once.*
go back to previous messages/skip to succeeding messages	Press <b>- ◀◀</b> or <b>▶▶ +</b> repeatedly. (During stop mode, keep the button pressed to skip the messages continuously.)

\* These operations are for when EASY-S (Easy Search function) of the menu is set to "OFF."



---

## Playing back a message repeatedly — Repeat Play

During playback, press **▶■**PLAY/ENTER for more than one second.

“↺” will be displayed and the selected message will be played back repeatedly.

To resume normal playback, press

**▶■**PLAY/ENTER again. To stop playback, press **■**(stop).

---

## Playing back all messages in a folder continuously — Continuous Play

You can select the continuous play mode with CONT in the menu. When you set CONT to “ON,” you can play back all messages in a folder continuously.

---

## Searching forward/backward during playback (Cue/Review)

To search forward, keep **▶▶I+** pressed during playback and release the button at the point you wish to resume playback.

To search backward, keep **- I◀◀** pressed during playback and release the button at the point you wish to resume playback.

If you keep **▶▶I+** or **- I◀◀** pressed, the unit starts to search at higher speed. For the first 7 seconds of cue/review, fast playback sound can be heard. When searching at a higher speed, playback sound will not be heard.

During cue/review, the counter will be displayed, regardless of the display mode setting.

### Tip

When fast playback is done to the end of the last message, "END" flashes 5 times. (You cannot hear the playback sound.) If you keep **◀◀** pressed while "END" is flashing, the messages are played back rapidly, and normal playback will start at the point you release the button.

When "END" stops flashing and the operation indicator goes off, the unit will stop at the beginning of the last message. If the last message is long and you wish to start playback at a later part of the message, keep **▶▶+** pressed to play back the message to the end and then press **◀◀** while "END" is flashing to go back to the desired point. (For messages other than the last one, go to the beginning of the next message and play backward to the desired point.)

---

## Locating quickly the point you wish to start playback (Easy Search)

When EASY-S is set to "ON" in the menu, you can advance approx. 10 seconds by pressing **▶▶+**. This function is useful when locating a desired point in a long recording. ("EASY-S" is displayed in the display window.)

---

## Playing Back a Message at a Desired Time with an Alarm

You can sound an alarm and start playback of a selected message at a desired time. If you select "B-ONLY" in Step 6, an alarm sounds only and playback will not start.

**1 Select the folder (See "Selecting the Folder" on page 17) and display the message you want to play back with an alarm.**

**2 Enter the alarm setting mode.**

- ① Press DISPLAY/MENU for more than 1 second until "MODE" appears in the display window.
- ② Press **◀◀** or **▶▶+** to select "ALARM OFF."  
(If the alarm has already set to the selected message, "ALARM ON" is displayed. If you do not wish to change the setting, press **■** (stop) and exit the menu mode.)

## Note

"ALARM OFF (or ON)" will not appear and the alarm cannot be set if the clock has not been set or no message has been recorded in the selected folder.

- Press ►■PLAY/ENTER.  
"OFF" starts to flash.
- Press –◀◀ or ▶▶+ to select "ON."  
"ON" starts to flash.
- Press ►■PLAY/ENTER.  
"DATE" will flash in the display window.

### 3 Set the alarm date.

#### To play back on a desired date

(the message will be played back at the same time on the same date every year until you erase the message)

- Press ►■PLAY/ENTER while "DATE" is flashing.  
The year digits will flash.
- Press –◀◀ or ▶▶+ to select the year digits and press ►■PLAY/ENTER.  
The month digits will flash.

- Press –◀◀ or ▶▶+ to select the month digits and press ►■PLAY/ENTER.  
The day digits will flash.

- Press –◀◀ or ▶▶+ to select the day digits.

#### To play back once a week

Press –◀◀ or ▶▶+ to select the day of the week.

#### To play back at the same time every day

Press –◀◀ or ▶▶+ to select "DAILY"

### 4 Press ►■PLAY/ENTER.

The hour digits will flash.

### 5 Set the alarm time.

- Press –◀◀ or ▶▶+ to select the hour digits and press ►■PLAY/ENTER.  
The minute digits will flash.
- Press –◀◀ or ▶▶+ to select the minute digits and press ►■PLAY/ENTER.  
"B-PLAY" will be displayed.

## 6 Set the alarm sound.

- 1 Press **◀◀** or **▶▶+** to select the alarm sound either from “B-PLAY” (playing back the message after the alarm) or “B-ONLY” (alarm only).
- 2 Press **▶■**PLAY/ENTER. “ALARM ON” will be displayed.

## 7 Press **■**(stop) to exit the menu mode.

“(●●)” is displayed when the number of the message with alarm setting is selected.

At the set time, the alarm will sound for about 10 seconds and the selected message will be played back. (If you have selected “B-ONLY,” only the alarm will sound.)

During playback, “ALARM” will flash in the display window.

When the playback ends, the unit will stop automatically at the beginning of that message.

## To listen to the same message again

Press **▶■**PLAY/ENTER. The same message will be played back from the beginning.

## To cancel the alarm setting before the playback starts

Press **■**(stop) while the alarm sound is heard. You can stop even when the HOLD function is activated.

## ■ Notes

- You cannot set the alarm if you have not set the clock or there is no message in the selected folder (the unit will not enter the alarm setting mode when you press DISPLAY/MENU in Step 2).
- If you try to set the alarm to play back a message at a previously set time on another message, “PRE SET” will be displayed, preventing new settings.
- If the alarm time comes while another message is being played back with an alarm, the playback stops and the new message will be played back.
- If the alarm time comes during recording, alarm will sound for 10 seconds after the recording is finished and playback begins. “(●●)” will flash when the alarm time comes.

- If more than one alarm time comes during recording, only the first message will be played back.
- When the alarm time comes when the unit is in the menu mode, alarm will sound and the menu mode will be canceled.
- If you erase the message you set the alarm to play back, the alarm setting will be canceled.
- If you divide a message with the playback alarm, playback will stop at the point you divided a message.
- You can adjust the playback volume with the VOL control.
- If the alarm time comes during erasing, alarm will sound for 10 seconds after the erasing is finished and playback begins.
- Alarm setting will not be canceled when the alarm playback finishes. To cancel alarm setting, see below.

## To cancel or change the alarm setting

- 1 Select the message you set the alarm to play back, and press DISPLAY/MENU for more than 1 second to enter the menu mode.**

- 2 Press  $\blacktriangleleft$  or  $\blacktriangleright$  to select "ALARM ON."**

- 3 Press  $\blacktriangleright$  ■PLAY/ENTER to flash "ON."**

- 4 To cancel the alarm setting: Press  $\blacktriangleleft$  or  $\blacktriangleright$  to flash "OFF" and press  $\blacktriangleright$  ■PLAY/ENTER.**

**To change the alarm setting:** Press  $\blacktriangleright$  ■PLAY/ENTER. When the alarm date is displayed, follow the Steps 3 to 6 of "Playing Back a Message at a Desired Time with an Alarm" to change the alarm setting.

- 5 Press ■(stop) to exit the menu mode.**

## Erasing Messages

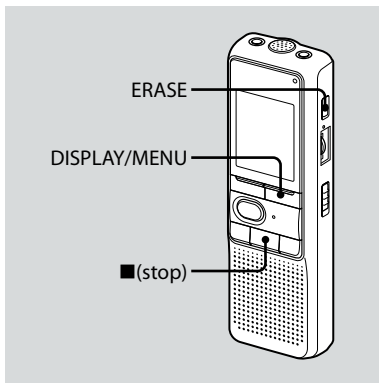

You can erase the recorded messages one by one or all messages in a folder at a time.

Note that once a recording has been erased, you cannot retrieve it.

## Erasing messages one by one

When a message is erased, the remaining messages will advance and renumbered so that there will be no space between messages.

**1 Press ERASE while playing back the message you want to erase or press ERASE for more than 1 second during stop mode.**

A beep will sound and the message number and "ERASE" will flash while the whole message is played back 10 times.

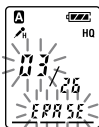

## 2 Press ERASE while the message is being played back.

The message is erased and the remaining messages will be renumbered. (For example, if you erase Message 3, Message 4 will be renumbered as Message 3. When erasing is completed, the unit will stop at the beginning of the following message.)

### To cancel erasing

Press ■(stop) before step 2.

### To erase other messages

Repeat steps 1 and 2.

### To erase a message partially

First divide the message and then follow the steps to erase the message.

---

## Erasing all messages in a folder

- 1 Select the folder you want to erase using DISPLAY/MENU. (See “Selecting the Folder” on page 17.)
- 2 While pressing ■(stop), press ERASE for more than 1 second.  
“ALL ERASE” will flash for 10 seconds.
- 3 While the display is flashing, press ERASE.

### To cancel erasing

Press ■(stop) before step 3.

# Dividing a Message

You can divide a message during recording or playback, so that the message is divided into two and the new message number is added to the divided message. By dividing a message, you can easily find the point you want to play back when you make a long recording such as a meeting.

You can divide messages until the total number of messages in the folder becomes 99.

**While recording or playing back a message, press DIVIDE at the point you want to divide.**

- **When you press DIVIDE during recording:** The new message number is added at the point you pressed the button, and the new message number and "DIVIDE" flash three times. The message will be divided into two; however, the messages will be recorded without a break.

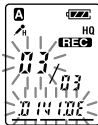

### Tip

You can divide a message during recording pause.

- **When you press DIVIDE during playback:** The message is divided into two at the point you pressed the button, and the new message number and "DIVIDE" flash three times. The message numbers of the following messages will increase by one.

Message 1	Message 2	Message 3	
	 A Message is divided.		
Message 1	Message 2	Message 3	Message 4

The message numbers are incremented.



## To play the divided message

Press **◀◀** or **▶▶** to display the message number as the divided messages each have message numbers.

## 💡 To play the divided messages continuously

Select "ON" for CONT in the menu as described in "Playing Back All Messages in a Folder Continuously."

## 📌 Notes

- If 99 messages have been recorded in a folder, you cannot divide a message. In that case, reduce the number of messages to 98 or less by erasing unnecessary messages or by moving some of the messages to another folder before dividing a message.
- If you divide a message with an alarm setting, the alarm setting remains only with the former message divided.
- You cannot divide a message in the first or the last 1 second.
- If you divide a message frequently, the unit may become unable to divide a message.
- Once a message is divided, you cannot combine the divided messages with the IC recorder. To combine the divided messages, use the supplied application software.

## Moving Messages to a Different Folder — Move Function

You can move the recorded messages to another folder.

- 1 While the unit is stopped, select the message you want to move.**
- 2 Press DISPLAY/MENU for more than 1 second until "MODE" appears in the display window.**
- 3 Press **◀◀** or **▶▶** to select "MOVE" and press **▶** **■**PLAY/ENTER.**

The destination folder indication flashes.

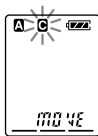

**4** Press **←** or **→** to select the folder to which you want to move the message.

**5** Press **▶** **■**PLAY/ENTER.

The message is moved in the destination folder.

**6** Press **■**(stop) to exit the menu mode.

### **To cancel moving the message(s)**

Press **■**(stop) before step 5.

#### **Note**

The move function does not duplicate a message in another folder. When you move a message to another folder, the one in the previous folder will be deleted.

# Selecting the Display Mode

You can select the display mode for the stop, recording and playback modes. Each time you press DISPLAY/MENU, the display mode will change as shown below:

### On the current time display

If the unit is left unoperated for more than 3 seconds in the stop mode, the display will show the current time, regardless of the display mode setting.

### Counter:

Elapsed playback/recording time in one message



### Remaining time (REMAIN):

In the playback mode: The remaining time of one message indication. In the stop and recording mode: The remaining recording time indication.



### Recorded date (REC DATE)\*:

The date the current message was recorded.



### Recorded time (REC DATE)\*\*:

The time the current message was recorded.

\* If the clock has not been set, "--Y--M--D" will be displayed.

\*\* If the clock has not been set, "--:--" will be displayed.

---

## Turning off the Beep Sound

**BEEP ON:** A beep will sound to indicate that operation has been accepted.

**BEEP OFF:** No beep sound will be heard except for the alarm and timer.

- 1 Press DISPLAY/MENU for more than 1 second until "MODE" appears in the display window.**
- 2 Press – I◀◀ or ▶▶I+ to display "BEEP ON (or OFF)" and press ►■PLAY/ENTER.**  
"ON (or OFF)" will flash.
- 3 Press – I◀◀ or ▶▶I+ to select "ON" or "OFF" and press ►■PLAY/ENTER.**  
The setting is completed.
- 4 Press ■(stop) to exit the menu mode.**

---

## Changing the Recording Mode

**HQ:** You can record with the high quality sound (monaural sound).

**SP:** You can record with better sound (monaural sound).

**LP:** You can record for longer time (monaural sound).

- 1 Press DISPLAY/MENU for more than 1 second until "MODE" appears in the display window.**
- 2 Make sure that "MODE" is displayed and press ►■PLAY/ENTER.**  
"HQ (or SP, LP)" will flash.
- 3 Press – I◀◀ or ▶▶I+ to select "HQ," "SP" or "LP" and press ►■PLAY/ENTER.**  
Now the setting is completed.
- 4 Press ■(stop) to exit the menu mode.**

The setting becomes effective and the normal screen will be displayed.

If the unit is left unoperated for more than 3 seconds, the display will show the current time and the selected recording mode will be displayed.

---

## Playing Back All Messages in a Folder Continuously

**CONT ON:** You can play back all messages in a folder continuously.

**CONT OFF:** Playback stops at the end of each message.

- 1 Press DISPLAY/MENU for more than 1 second until "MODE" appears in the display window.**
- 2 Press  $\blacktriangleleft\blacktriangleleft$  or  $\blacktriangleright\blacktriangleright+$  to display "CONT" and press  $\blacktriangleright\blacksquare$ PLAY/ENTER.**  
"OFF (or ON)" will flash.
- 3 Press  $\blacktriangleleft\blacktriangleleft$  or  $\blacktriangleright\blacktriangleright+$  to select "ON" or "OFF" and press  $\blacktriangleright\blacksquare$ PLAY/ENTER.**  
Now the setting is completed.
- 4 Press  $\blacksquare$ (stop) to exit the menu mode.**

---

## Turning off the Operation Indicator (LED)

During recording and playback, the operation indicator lights or flashes. You can set the operation indicator to turn off even in operation.

- 1 Press DISPLAY/MENU for more than 1 second until "MODE" appears in the display window.**
- 2 Press  $\blacktriangleleft\blacktriangleleft$  or  $\blacktriangleright\blacktriangleright+$  to display "LED" and press  $\blacktriangleright\blacksquare$ PLAY/ENTER.**  
"ON (or OFF)" will flash.
- 3 Press  $\blacktriangleleft\blacktriangleleft$  or  $\blacktriangleright\blacktriangleright+$  to select "OFF" and press  $\blacktriangleright\blacksquare$ PLAY/ENTER.**  
Now the setting is completed.
- 4 Press  $\blacksquare$ (stop) to exit the menu mode.**

### **$\blacksquare$ Note**

When the IC recorder is connected to the USB connector of your computer, the operation indicator always flashes regardless of the menu setting.

## **Using the Supplied Digital Voice Editor Software**

### **What you can do using the Digital Voice Editor software**

The Digital Voice Editor software allows you to transfer the messages to your display monitor, to save them on your computer's hard disk, and to play back and edit them.

- Transferring the messages recorded on the IC recorder to your computer.
- Saving the messages on your computer's hard disk.
- Viewing, playing, or editing the messages on your computer.
- Transferring messages back to the IC recorder. You can add an MP3 file as it is.
- Sending a voice e-mail message using MAPI e-mail software.
- Using the transcribing keys to play back a message and transcribe it using a word-processor or an editor's window.

- Transcribing your IC recorder message using Dragon NaturallySpeaking® speech-recognition software (Only when Dragon NaturallySpeaking version 5.0 (or higher) Preferred or Professional Edition is installed on your computer).
- Using the CD Recording Tool for DVE, you can play tracks of a CD inserted into the computer's CD drive and save CD tracks onto the PC hard disk as a file format that the Digital Voice Editor supports. Saved files can then be added to an IC recorder using the Digital Voice Editor.

Use of the CD Recording Tool for DVE is limited to the personal purposes.

## System requirements

### Operating Systems:

Windows Vista® Home Basic  
Windows Vista® Home Premium  
Windows Vista® Business  
Windows Vista® Ultimate  
Windows® XP Home Edition Service Pack 2 or higher  
Windows® XP Professional Service Pack 2 or higher  
Windows® XP Media Center Edition Service Pack 2 or higher  
Windows® XP Media Center Edition 2004 Service Pack 2 or higher  
Windows® XP Media Center Edition 2005 Service Pack 2 or higher  
Windows® 2000 Professional Service Pack 4 or higher  
Pre-Installed

### **Note**

64bit OS is not supported.

### Hardware Environment:

- Computer: IBM PC/AT or compatible
- CPU : 266 MHz Pentium® II processor or higher (For Windows Vista®, 800MHz Pentium® III processor or higher)
- RAM: 128MB or more (For Windows Vista®, 512MB or more)
- Hard disk space: 70MB or more
- CD-ROM drive (When creating an audio CD or data CD, a CD-R/RW drive is needed)
- Port: USB port
- Sound board: Sound cards compatible with any of the supported Microsoft® Windows® operating systems
- Display: High color (16bit) or more and 800x480 dots or more
- Internet access for Voice Mail function and CD database service

### **Note**

The following systems are not supported:

- OS other than the ones indicated above
- Personally constructed PCs or operating systems
- Upgraded OS
- Multi-boot environment
- Multi-monitor environment

## Note on transcribing a message

When you use Dragon NaturallySpeaking® speech-recognition software to transcribe a message, your computer must also meet the system requirements that the Dragon NaturallySpeaking requires. For latest version and availability of Dragon NaturallySpeaking in each region, please refer to the following page: <http://www.nuance.com/>

## Note on sending a voice e-mail

When you use Microsoft® Outlook Express 5.0/5.5/6.0 to send a voice e-mail of a message, your computer must also meet the system requirements that the Outlook Express requires.

---

## Installing the software

Install the Digital Voice Editor software on your computer's hard disk.

### ■ Notes

- When you install the Digital Voice Editor, you can create all the compatible file types except for the DVF (TRC) files. (You can play back the DVF (TRC) files.)  
**When installing both types of the Digital Voice Editor, make sure to select overwrite installation to handle all the compatible file formats.**
- Do not connect the IC recorder to the computer before installing the Software. Or do not remove or connect the IC recorder during installing the Software; The IC recorder may not be recognized or the Software may not be installed successfully.
- Be sure to close all running programs before installing the Digital Voice Editor software.
- When installing or uninstalling the software in Windows® 2000 Professional, make sure to log on Windows as the user name of "Administrator".



- When installing or uninstalling the software in Windows Vista® Home Basic/Windows Vista® Home Premium/Windows Vista® Business/Windows Vista® Ultimate/Windows® XP Home Edition Service Pack 2 or higher/Windows® XP Professional Service Pack 2 or higher/Windows® XP Media Center Edition Service Pack 2 or higher/Windows® XP Media Center Edition 2004 Service Pack 2 or higher/Windows® XP Media Center Edition 2005 Service Pack 2 or higher, log on as a user name with the “Computer administrator” user account. (To find if the user name has a “Computer administrator” user account, open the “User Accounts” from the “Control Panel” and refer to the section beneath the user name being displayed.)
- When the “Memory Stick Voice Editor 1.0/1.1/1.2/2.0” software has already been installed, installing the supplied software will automatically remove the “Memory Stick Voice Editor” software. (Messages are not removed.)
- After installing, the Microsoft DirectX module is also installed depending on the operation system of your computer. This module is not deleted after uninstalling the software.
- After installing the Digital Voice Editor software, do not install the “Memory Stick Voice Editor 1.0/1.1/1.2/2.0” software. The Digital Voice Editor will not work properly.
- With the supplied software, you can save or edit the messages in the “Memory Stick.”

**1 Make sure that the IC recorder is not connected and then turn on your computer and start up Windows.**

**2 Insert the supplied CD-ROM into the CD-ROM drive.**

The [IC Recorder Software Setup] menu starts up automatically and the [Welcome to IC Recorder Software Setup] window appears. If the [Welcome to IC Recorder Software Setup] menu does not start up, open the [DVE] folder in the [Setup] folder on the CD-ROM, and then double click [setup.exe].

**3 Make sure that you accept the terms of the license agreement, select [I accept the terms of the license agreement], and then click [Next].**

The [Software Install] window appears.

**4 Select [Digital Voice Editor Ver. 3.1.02], and then click [Install].**

Follow the instructions on the screen to make the settings required for installation.

## **If you have already installed a previous version of the Digital Voice Editor or any version of the “Memory Stick Voice Editor”**

The dialog box used to uninstall a previous version of the Digital Voice Editor or any version of the “Memory Stick Voice Editor” will be displayed. Follow the instructions on the screen to uninstall the software. The message files are not removed.

## **When the dialog box used to input the owner name is displayed**

Input the owner name.

The owner name is the setting for privileges and limitations in the Digital Voice Editor usage.

## **Notes**

- You cannot change the owner name once it is entered. Please write down and keep it for future reference.
- A file recorded from a CD cannot be handled except on the computer where the file is recorded. Handling of a file is limited to the computer bearing the same owner name input during the Digital Voice Editor installation. If any illegal data modification is attempted, or a file is used for other than the private purposes, the file may become unplayable or the Digital Voice Editor may become inoperable.

## **When the dialog box used to select how to save files is displayed**

When you save files recorded using the IC recorder onto the computer named above, you can select whether you wish to convert them into the MP3 format. Select the desired setting.

## **When the dialog box used to select the language to be used for the help is displayed**

Click the language you want to use for the help.

**5** When the [Ready to Install the Program] window appears, click [Install].

The installation starts.

**6** When the [InstallShield Wizard Complete] window appears, select [Yes, I want to restart my computer now], and then click [Finish].

The computer will be restarted.

When the computer has been restarted, installation is completed.

## Uninstalling the software

When you wish to uninstall the software, follow the steps below.

### For Windows 2000 or Windows XP

- 1 Click [Start] and select [Settings], [Control Panel] and then [Add or Remove Programs] or [Add/Remove Applications].
- 2 Select [Digital Voice Editor 3] from the list and click [Remove] or [Change/Remove].
- 3 Follow the instructions on the screen.

### For Windows Vista

- 1 Click [Start] – [Control Panel] – [Programs], and then select and click [Uninstall a Program] from the category.
- 2 Select [Digital Voice Editor 3] from the list and click [Uninstall].
- 3 Click [Continue] in the [User Account control] window.
- 4 Follow the instructions on the screen.

## Note

If you wish to move the software to another drive or directory after it is installed, you must uninstall the software first, and then re-install it. The software does not work properly if you just move the software files.

## Tip

- Uninstallation does not remove the message files.

## Connecting the IC recorder to your computer

You can transfer the IC recorder data onto your computer by connecting the IC recorder to the computer. Use the USB connecting cable supplied with the IC recorder to connect the USB connectors of the IC recorder and your computer.

The IC recorder is recognized by the computer as soon as the cable is connected. You can connect or disconnect the cable when the IC recorder and the computer are turned on or off.

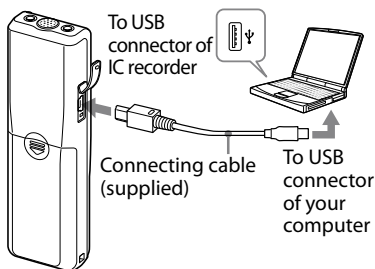

## Notes

- Be sure to install the Digital Voice Editor software before connecting the IC recorder to your computer. Otherwise, a message like [Found New Hardware Wizard] may appear when you connect the IC recorder to your computer. In this case, click [Cancel].
- Do not connect more than two USB devices to your computer. Normal operation will not be guaranteed.
- Use of this IC recorder with a USB hub or a USB extension cable is not guaranteed.
- A malfunction may occur depending on the USB devices connected at any one time.
- Before connecting the IC recorder to the computer, check that batteries are inserted in the IC recorder.
- When you connect the IC recorder to the computer, make sure that the IC recorder is in the stop mode.
- It is recommended that you disconnect the cable from the computer when you do not use the Digital Voice Editor.

## Referring to the help files

For details on each operation, refer to the help files.

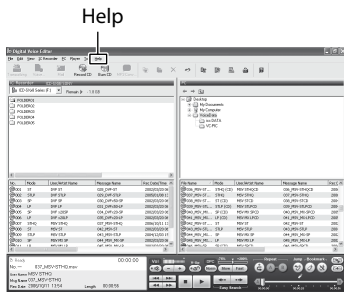

# Troubleshooting

Before taking the unit for repair, check the following sections. Should any problem persist after you have made these checks, consult your nearest Sony dealer.

## IC recorder

Symptom	Remedy
The unit does not operate.	<ul style="list-style-type: none"><li>• The batteries have been inserted with incorrect polarity (page 9).</li><li>• The batteries are weak.</li><li>• The buttons are locked with the HOLD switch (page 7). (If you press any button, "HOLD" will flash three times.)</li></ul>
No sound comes from the speaker.	<ul style="list-style-type: none"><li>• The ear receiver or headphones are plugged in.</li><li>• The volume is turned down completely.</li></ul>
"FULL" is displayed and you cannot start recording.	<ul style="list-style-type: none"><li>• The memory is full. Erase some of the messages (page 30).</li><li>• 99 messages have been recorded in the selected folder. Select another folder or erase some of the messages (page 30).</li></ul>
Noise is heard.	<ul style="list-style-type: none"><li>• An object, such as your finger, etc., accidentally rubbed or scratched the unit during recording so that noise was recorded.</li><li>• The unit was placed near an AC power source, a fluorescent lamp or a mobile phone during recording or playback.</li><li>• Plug of the connected microphone was dirty when recording. Clean the plug.</li><li>• Ear receiver/headphones plug is dirty. Clean the plug.</li></ul>
Recording level is low.	<ul style="list-style-type: none"><li>• Set the microphone sensitivity to "H (high)" using the menu (page 18).</li></ul>
Recording is interrupted.	<ul style="list-style-type: none"><li>• The advanced VOR function is activated. Set VOR to "OFF" (page 17).</li></ul>

Symptom	Remedy
Recording level is unstable (when recording music, etc.).	<ul style="list-style-type: none"> <li>This unit is designed to automatically adjust the recording level when recording meetings, etc., and is not suitable for music recording.</li> </ul>
"--Y--M--D" or "--:--" is displayed.	<ul style="list-style-type: none"> <li>You have not set the clock (page 11).</li> </ul>
"--Y--M--D" or "--:--" is displayed on the REC DATE display.	<ul style="list-style-type: none"> <li>The date and time of recording will not be displayed if you recorded the message when the clock was not set.</li> </ul>
You cannot divide a message.	<ul style="list-style-type: none"> <li>You cannot divide a message in a folder which has 99 messages (page 32).</li> <li>If you divide messages frequently, the unit may become unable to divide a message.</li> <li>You cannot divide a message in the first or the last 1 second of a message.</li> </ul>
You cannot record messages up to the maximum recording time.	<ul style="list-style-type: none"> <li>If you record messages in a mixture of HQ, SP and LP modes, the recordable time varies from the maximum HQ mode recording time to the maximum LP mode recording time (page 15).</li> <li>No more recording can be made when 99 messages each have been recorded in a folder.</li> <li>Due to the limitation of the IC recording system, this unit records in the minimum recording unit. If the length of each message cannot be divided by the minimum recording unit, the remaining recording time may decrease by more than the total length of the messages.</li> </ul>

<b>Symptom</b>	<b>Remedy</b>
The remaining time displayed in the display window is shorter than that displayed in the supplied Digital Voice Editor software.	<ul style="list-style-type: none"><li>• The unit requires a certain amount of memory for system operation. That amount is subtracted from the remaining time, which is the reason for the difference.</li></ul>
The unit does not operate correctly.	<ul style="list-style-type: none"><li>• Take out the batteries and insert them again (page 9).</li></ul>
Please note that recorded messages may be erased during service or repair work.	



## Digital Voice Editor

Refer to the Help files of the Digital Voice Editor software, too.

Symptom	Remedy
The Digital Voice Editor software cannot be installed.	<ul style="list-style-type: none"><li>• The free disk or memory space on the computer is too small. Check the hard disk and memory space.</li><li>• You are trying to install the software into the operating system that the Digital Voice Editor software does not support.</li><li>• In Windows Vista® Home Basic/Windows Vista® Home Premium/Windows Vista® Business/Windows Vista® Ultimate/Windows® XP Home Edition Service Pack 2 or higher/Windows® XP Professional Service Pack 2 or higher/Windows® XP Media Center Edition Service Pack 2 or higher/Windows® XP Media Center Edition 2004 Service Pack 2 or higher/Windows® XP Media Center Edition 2005 Service Pack 2 or higher, you log on as a user name belonging to a user account with limitations. Make sure to log on as a user name with the “Computer administrator” user account.</li><li>• In Windows® 2000 Professional, make sure to log on as the user name of “Administrator.”</li></ul>
The IC recorder or “Memory Stick” cannot be properly connected.	<ul style="list-style-type: none"><li>• Check that the installation of the software has been successful. Also check the connection as follows:<ul style="list-style-type: none"><li>– When using an external USB hub, connect the IC recorder directly to the computer.</li><li>– Disconnect and then connect the cable with the IC recorder.</li><li>– Connect the IC recorder to another USB connector.</li></ul></li><li>• Your computer may be in the system standby/hibernate mode. Do not let your computer enter into the system standby/hibernate mode while being connected to the IC recorder.</li></ul>

<b>Symptom</b>	<b>Remedy</b>
The IC recorder does not operate.	<ul style="list-style-type: none"> <li>• You may format the memory of the IC recorder. Use the IC recorder formatting function to format the memory.</li> </ul>
Messages cannot be played back./Playback sound volume is too low.	<ul style="list-style-type: none"> <li>• No sound board is installed.</li> <li>• No speaker is built-in or connected to the computer.</li> <li>• The volume of the sound is turned down.</li> <li>• Turn up the volume on the computer. (Refer to the instruction manual of the computer.)</li> <li>• The volume of WAV files can be changed and saved using the "Increase Volume" feature of the Microsoft Sound Recorder.</li> </ul>
Saved message files cannot be played back or edited.	<ul style="list-style-type: none"> <li>• You cannot play back a message whose file format the Digital Voice Editor software does not support. Depending on the file format, you cannot use part of editorial features of the software.</li> </ul>
Counter or slider moves incorrectly. There is noise.	<ul style="list-style-type: none"> <li>• This happens when you play back messages that you divided, combined, overwrote, or added a recording. Save a message in the hard disk first, and then add it to the IC recorder. Select the saving file format that suits the IC recorder you use.</li> </ul>
Operation is slow when there are many messages.	<ul style="list-style-type: none"> <li>• When the total number of messages increases, the operation becomes slower, regardless of the length of the recording time.</li> </ul>
Display does not work during saving, adding, or deleting of messages.	<ul style="list-style-type: none"> <li>• It takes a longer time to copy or delete long messages. After completing operations, the display works normally.</li> </ul>
It takes too long to convert a file format.	<ul style="list-style-type: none"> <li>• The time required for file conversion becomes longer as the file size is bigger.</li> </ul>

<b>Symptom</b>	<b>Remedy</b>
The software 'hangs' when the Digital Voice Editor software starts up.	<ul style="list-style-type: none"><li data-bbox="344 111 943 215">• Do not disconnect the connector of the IC recorder while the computer is communicating with the IC recorder. Otherwise the computer operations become unstable or the data inside the IC recorder may be damaged.</li><li data-bbox="344 220 943 272">• There may be conflict between the software and other driver or application.</li><li data-bbox="344 277 943 381">• Do not install the "Memory Stick Voice Editor" software and the Digital Voice Editor Ver. 2x software after you installed the Digital Voice Editor software. The Digital Voice Editor may not operate properly.</li></ul>

## **Precautions**

### **On power**

- Operate the unit only on 3 V DC. Use two LR03 (size AAA) alkaline batteries.

### **On safety**

- Do not operate the unit while driving, cycling or operating any motorized vehicle.

### **On handling**

- Do not leave the unit in a location near heat sources, or in a place subject to direct sunlight, excessive dust or mechanical shock.
- Should any solid object or liquid fall into the unit, remove the batteries and have the unit checked by qualified personnel before operating it any further.

### **On noise**

- Noise may be heard when the unit is placed near an AC power source, a fluorescent lamp or a mobile phone during recording or playback.

- Noise may be recorded when an object, such as your finger, etc., rubs or scratches the unit during recording.

### **On maintenance**

- To clean the exterior, use a soft cloth slightly moistened in water. Do not use alcohol, benzine or thinner.

If you have any questions or problems concerning your unit, please consult your nearest Sony dealer.

### **Backup recommendations**

To avoid potential risk of data loss caused by accidental operation or malfunction of the IC recorder, we recommend that you save a backup copy of your recorded messages on a tape recorder or to a computer, etc.

# Specifications

## IC recorder section

### Recording media

Built-in flash memory 512 MB, Monaural recording

A part of the memory capacity is used as a management area.

### Recording time

HQ: 59 hours 45 minutes

SP: 159 hours 20 minutes

LP: 261 hours 45 minutes

### Frequency range

HQ: 260 Hz - 6,800 Hz

SP/LP: 220 Hz - 3,400 Hz

## General

### Speaker

Approx. 2.8 cm (1 1/8 in.) dia.

### Power output

250 mW

### Input/Output

- Headphone jack (minijack) for 8 - 300 ohms ear receiver/headphones
- Microphone jack (minijack, monaural)  
Plug in power  
Minimum input level 0.6 mV  
3 kilohms or lower impedance microphone
- USB connector

## Power requirements

Two LR03 (size AAA) alkaline batteries: 3 V DC

## Dimensions (w/h/d) (not incl. projecting parts and controls)

34.6 × 109.2 × 18.4 mm (1 3/8 × 4 3/8 × 3/4 in.)

## Mass (incl. batteries)

67 g (2.4 oz)

## Supplied accessories

Operating instructions (1)

LR03 (size AAA) alkaline batteries (2)

Headphone (1) (excluding the U.S.A., Canada and Europe)

Carrying pouch (1) (excluding the U.S.A., Canada and Europe)

USB connecting cable (1)

Application software (CD-ROM) (1)

## Optional accessories

Electret Condenser Microphone ECM-DM5P,

ECM-CZ10, ECM-TL1 (for telephone recording)

Audio connecting cable RK-G64HG /RK-G69HG (excluding Europe)

Active speaker SRS-T88, SRS-T80

Your dealer may not handle some of the above listed optional accessories. Please ask the dealer for detailed information.

Design and specifications are subject to change without notice.

## Trademarks

- Microsoft, Windows, Windows Vista, Outlook, DirectX are registered trademarks or trademarks of Microsoft Corporation in the United States and/or other countries.
- Apple and Macintosh are trademarks of Apple Inc., registered in the USA and other countries.
- Pentium is a registered trademark of Intel Corporation.
- Nuance, the Nuance logo, Dragon NaturallySpeaking, and RealSpeak are trademarks and/or registered trademarks of Nuance Communications, Inc., and/or its affiliates in the United States and/or other countries.  
© 2007 Nuance Communications, Inc.  
All rights reserved.
- MPEG Layer-3 audio coding technology and patents licensed from Fraunhofer IIS and Thomson.
- "Memory Stick" and  are trademarks of Sony Corporation.
- "Memory Stick Duo" and **MEMORY STICK DUO** are trademarks of Sony Corporation.
- "Memory Stick PRO Duo" and **MEMORY STICK PRO DUO** are trademarks of Sony Corporation.
- "MagicGate Memory Stick" is the trademark of Sony Corporation.
- "LPEC" and **LPEC** are registered trademarks of Sony Corporation.
- US and foreign patents licensed from Dolby Laboratories.



Music Identification Technology and associated data will be supplied from the Gracenote®. Gracenote MusicID is the industry standard for digital music identification for both CDs and individual music files. For details, see the following web site: [www.gracenote.com](http://www.gracenote.com)

Gracenote® is a registered trademark of the Gracenote, Inc. The Gracenote logo and logotype, and "Powered by Gracenote" logo are trademarks of the Gracenote. For use of the Gracenote services, see the following web page: [www.gracenote.com/corporate](http://www.gracenote.com/corporate)

All other trademarks and registered trademarks are trademarks or registered trademarks of their respective holders. Furthermore, "™" and "®" are not mentioned in each case in this manual.

The "Digital Voice Editor" uses software modules as shown below:  
Microsoft® DirectX®  
©2001 Microsoft Corporation. All rights reserved.



<http://www.sony.net/>



\* 3 2 9 5 2 6 8 1 1 \* (2)