

Easy Baking

RECIPES & INSTRUCTION MANUAL

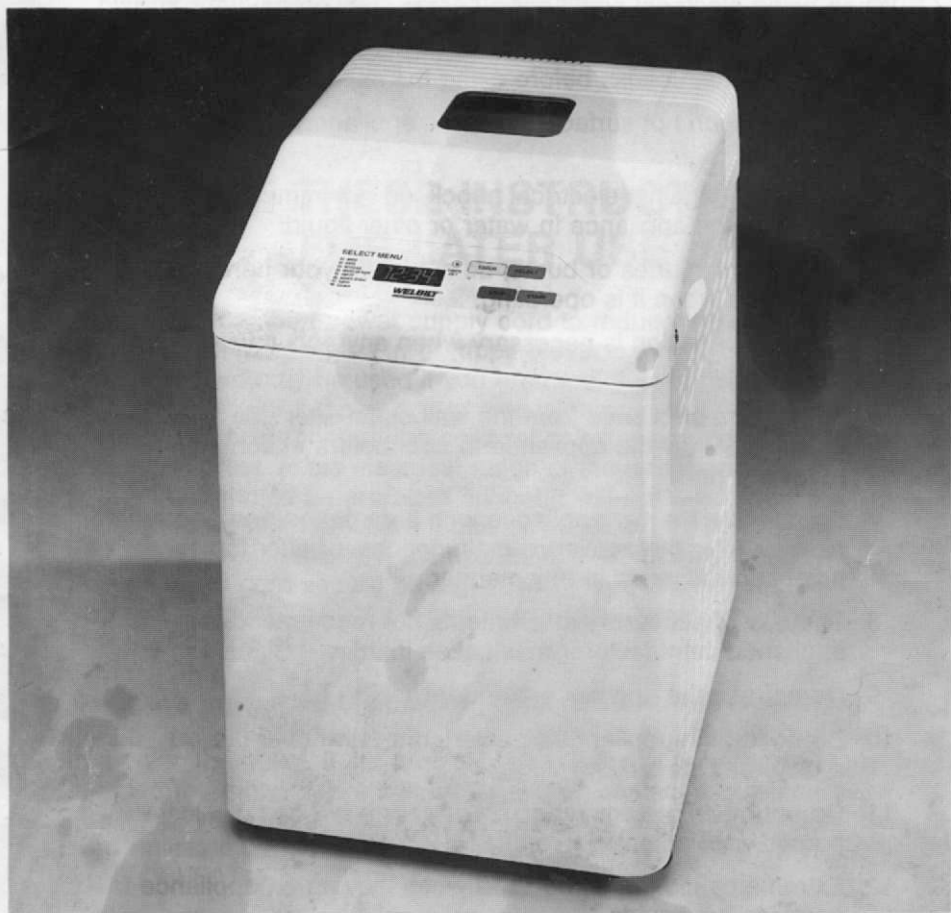

THE BREAD MACHINE
MODEL ABM3000

WELBILT®

IMPORTANT SAFEGUARDS

HOUSEHOLD USE ONLY

When using electrical appliances, basic safety precautions should always be followed, including the following:

1. Read all instructions before using the appliance.
2. Do not touch hot surfaces. Use the appliance's handles or knobs.
3. To protect against electrical shock, do not immerse power cord, plugs, or the appliance in water or other liquid.
4. To prevent injuries or burns, do not insert your hand into the appliance when it is operating.
5. Close supervision is necessary when any appliance is used by or near children.
6. Unplug the appliance from the wall outlet after use and before cleaning. Allow the appliance to cool before attaching or removing parts.
7. Do not operate any appliance with a damaged power cord or plug, or after the appliance malfunctions, or after the appliance has been damaged in any manner.
8. The use of accessory attachments not recommended by the appliance manufacturer may cause injuries.
9. Do not use the appliance outdoors.
10. Do not let the appliance's power cord hang over the edge of a table or counter.
11. Do not place the appliance on or near a hot gas or electric burner or in a heated oven.
12. Extreme caution must be used when moving an appliance that contains hot liquids.

-
13. When using an extension cord, always attach the plug to the appliance first, then plug the extension cord into the wall outlet. To disconnect, first turn any appliance controls to OFF, then disconnect the plug from the wall outlet.
 14. Do not use any appliance for anything other than its intended use.

SAVE THESE INSTRUCTIONS FOR LATER USE

This unit has a short power supply cord to reduce the risk resulting from becoming entangled in or tripping over a longer cord. An extension cord may be used if you are careful in its use. If a longer detachable power supply cord or extension cord is used, (1) the marked electrical rating of the cord set or extension cord should be at least as great as the electrical rating of the appliance, and (2) the cord should be arranged so that it will not drape over the countertop or tabletop where it can be pulled on by children or tripped over accidentally. If the appliance is of the grounded type, the extension cord should be a grounding type 2-wire cord. The power cord must be kept dry and must not be bent or have anything put on top of it.

To reduce the hazard of potential shock, this item has a polarized plug (one blade is wider than the other), which will fit only one way in a polarized outlet. If the plug does not fit the outlet properly, turn the plug the other way, if it still does not fit, contact a qualified electrician for assistance. Never use this plug with an extension cord unless it fits properly. **DO NOT ATTEMPT TO DEFEAT THIS SAFETY FEATURE.**

Easy Baking

Recipes & Instruction Manual

Published by Cookbook Resource USA, Ltd
Milwaukee/1995

copyrights © 1992 & 1993 by
Cookbook Resource USA, Ltd.
and
Appliance Corp. of America

Responsibility for the success and/or originality of the recipes for this book contained herein rests with Welbilt Appliance, Inc. All rights reserved. No part of the contents of this book may be reproduced by any means without permission of the copyright co-owners. Cookbook Resource USA is a registered trademark of Cookbook Resource USA, Ltd. WELBILT® is a registered trademark of Appliance Corp. of America

Before using the Bread Machine for the first time, please read the instructions contained in this manual. Follow the steps carefully and use the ingredients specified in this book.

If you should have any questions or problems, please write to:

Welbilt Bread Machine Customer Service
PO BOX 220709
Great Neck, N · Y · 11021
Or call us at:
1-800-872-1656

CONTENTS

Instruction Manual

Control Panel	8
Bread Machine Programs	9
Programmable Timer	10
Your Welbilt Machine	11
Suggestions for Safety & Enjoyment	12
Kneading, Rising & Baking Cycles: CHART	13
Kneading, Rising & Baking Cycles: STEP-BY-STEP	14
Inserting/Removing Pan & Cleaning	15

Insider's Guide to Easy Baking

Traditional Yeast Breads	16
--------------------------------	----

Yeast Breads Made Automatically

Basic Breads

Basic White Bread	22
Basic White Bread Variations	23
Rye Bread	24
Onion Bread	25
Cinnamon Nut Raisin Bread	26
Egg Bread	27
Chevre-Cracked Pepper Bread	28
Cheddar Bacon Bread	29
Maple Walnut Wheat Bread	30
Country Raisin Bread	31

Whole Grain Breads

100% Whole Wheat Bread	32
Sunflower Oatmeal Bread	33
Honey Oats 'N' Barley Bread	34
Dark Pumpernickel Bread	35
Triple Wheat Bread	36
Shredded Wheat Bread	37

(continued next page)

CONTENTS (cont'd.)

Hand-Shaped Breads

Pizza Dough	38
Pizza Dough Variations	39
Bagels	40
French Bread	42
Challah	44
Cinnamon Rolls	45
Bread Sticks	46
Dinner Rolls	47
Holiday Bread	48
Croissants	49

Practical Solutions	51
----------------------------------	----

Trouble Shooting for The Bread Machine	55
---	----

Instruction Manual



CONTROL PANEL

ABM3000

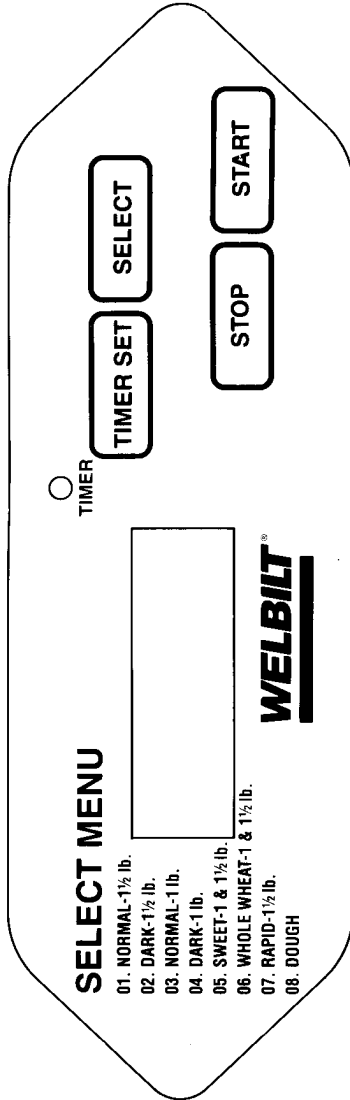

CONTROL PANEL (cont'd.)

BREAD MACHINE PROGRAMS

Your WELBILT® Bread Machine has eight separate programs to choose from:

Making 2, 3 Cups Basic Bread Automatically:

Press SELECT to choose either #01 (NORMAL 1½ lb.), #02 (DARK 1½ lb.), #03 (NORMAL 1 lb.) or #04 (DARK 1 lb.) program when making bread automatically. Press START. The Bread Machine will knead and rise the dough twice and then bake it to perfection.

Making 2, 3 Cups Sweet Bread Automatically:

Press SELECT to choose #05 (SWEET 1 & 1½ lb.) program when making sweet bread automatically. Press START. The Bread Machine will knead and rise the dough twice and then bake it to perfection.

Making Whole Quick Bread Automatically:

Press SELECT to choose #06 (WHOLE WHEAT 1 & 1½ lb.) program when making whole wheat or whole grain breads automatically. Press START. The Bread Machine will knead and rise the dough twice and then bake it to perfection.

Making 3 Cups Basic Bread Automatically in RAPID cycle:

Press SELECT to choose #07 (RAPID 1½ lb.) program when making basic bread automatically in a shorter time. Press START. The Bread Machine will knead and rise the dough twice and then bake it to perfection in 2 hours and 50 minutes.

Making Yeast Dough Automatically:

Choose #08 the DOUGH program by pressing the SELECT button. Press START. The Bread Machine will knead and rise the dough twice. At the end of the program you will remove the dough and hand-shape it according to your recipe. Dough will then be baked in a conventional oven.

(continued next page)

CONTROL PANEL (cont'd.)

PROGRAMMABLE TIMER

To set the programmable TIMER, follow these steps:

- Place the ingredients in the bread pan.
- Select the program you desire.
- Decide how much later you want the bread or dough to be ready. For example: it is 8:00AM and you want to have bread ready at 6:00PM, or 10 hours later.
- Set the programmable TIMER by pressing the TIMER button the appropriate number of times until you get the number of hours and minutes later that you want your bread or dough to be ready. For example: before leaving for work at 8:00AM you decide to make a Basic White Bread and wish it ready for dinner at 6:00PM (or 10 hours later). Press the TIMER button until 10:00 appears on the control panel. Press START. Your Bread Machine will begin making your bread at the appropriate time for it to be ready at exactly 6:00PM.
- If you wish to re-program for another time, press STOP/RESET and repeat the steps.
- SPECIAL NOTE:** Do not use the Programmable TIMER with recipes that contain perishable ingredients.

YOUR WELBILT® BREAD MACHINE

ABM3000

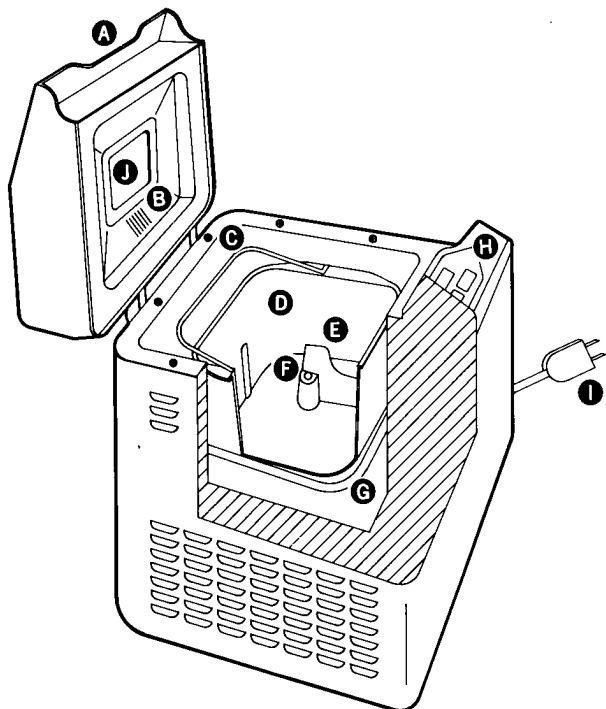

- A. Lid
- B. Air Exhaust
- C. Pan Handle
- D. Bread Pan
- E. Dough Blade
- F. Drive Shaft
- G. Heating Element
- H. Control Panel
- I. Power Cord
- J. Viewing Window

SUGGESTIONS FOR MAXIMUM ENJOYMENT AND SAFETY

1. The baking portion and lid of the Bread Machine become extremely hot during baking. Always use a kitchen mitt or pot holder when touching these parts.
2. Do not operate this appliance on the same circuit as other high voltage appliances.
3. Position the Bread Machine at least 4 inches from the front of the counter or working surface. Do not place any flammable materials or objects on top of the appliance when plugged in or during operation.
4. Do not use the Bread Machine near any electrical equipment like radios, TVs, or stereos since poor reception or interference may occur.
5. Always use the Bread Machine on a clean, dry work surface away from exposed elements, direct sunlight, or other sources of heat or cold.
6. Only use the Bread Machine on a non-flammable work surface or counter. Never use on floor or on carpeting or on top of any cloth objects like tablecloths or placemats.
7. Never stick your hand or any kitchen utensils into the bread pan during operation.
8. Do not use accessories or attachments not included or recommended by Welbilt.
9. Do not put any components in the dishwasher.
10. Do not attempt to tamper with or make any adjustments to the electrical components or parts.
11. Do not use this appliance other than for its intended use.

KNEADING, RISING and BAKING CYCLES

This chart (shown in MINUTES) is provided so that you will better understand how your Welbilt® Bread Machine works.

PROGRAM	NORMAL		DARK		SWEET		WHOLE WHEAT		RAPID		DOUGH Regular
	1 lb.	1½ lb.	1 lb.	1½ lb.	1 lb.	1½ lb.	1 lb.	1½ lb.	1 lb.	1½ lb.	
PRE-HEAT	4	4	4	4	4	4	5	5	—	—	—
MIXING (FIRST KNEADING)	10	15	10	15	15	15	20	20	15	15	15
REST	24	28	24	28	28	28	30	30	12	12	30
MIXING (SECOND KNEADING)	22	23	22	23	23	23	25	25	23	23	23
ADD FRUIT/NUTS	BEEP	BEEP	BEEP	BEEP	BEEP	BEEP	BEEP	BEEP	BEEP	BEEP	BEEP
RISING (FIRST)	20	20	20	20	20	20	30	30	10	10	20
PUNCH DOWN (FIRST)	3 sec.	3 sec.	3 sec.	3 sec.	3 sec.	3 sec.	3 sec.	3 sec.	3 sec.	3 sec.	3 sec.
RISING (SECOND)	60	60	60	60	60	60	60	60	60	60	—
BAKING	50	50	50	50	50	50	50	50	50	50	—
TOTAL TIME	3:00	3:20	3:00	3:20	3:20	3:20	3:40	3:40	2:50	2:50	1:28
KEEP WARM	3:00	3:00	3:00	3:00	3:00	3:00	3:00	3:00	3:00	3:00	—

IMPORTANT:

Your Welbilt Bread Machine will pre-warm all the ingredients placed in the baking pan to proper temperature to guarantee the best results. It is extremely important to understand your bread machine IS WORKING PROPERLY when you push the START pad and no blade action starts. As mentioned above, YOUR MACHINE IS PRE-WARMING THE INGREDIENTS.

KNEADING, RISING and BAKING CYCLES (cont'd.)

Warming Cycle: Since temperature plays such an important role in making good bread and dough, your Welbilt Bread Machine will warm the ingredients to the optimum temperature to ensure the best results.

First Mixing (Kneading): The Bread Machine will intermittently mix the ingredients for a few seconds at which time it will then begin to knead the dough to form a smooth ball.

Second Mixing (Kneading): Kneading the dough makes the gluten elastic enough to form the structure of the bread.

Add Fruit/Nuts; The Bread Machine will beep several times a few minutes before the end of the second kneading. This is the best time to add ingredients like nuts and raisins, etc.

First Rising: When dough has been well-kneaded, the gluten forms thin elastic strands that make up the structure of the bread. As the yeast develops and multiplies, it produces carbon dioxide gas. The gas becomes trapped in the gluten strands forming bubbles. As these bubbles collect, the dough expands and rises.

First Punch Down: The Bread Machine kneads the dough for a few seconds to deflate it.

Second Rise: The gluten strands are now strong enough to support the loaf. The yeast will once again produce carbon dioxide gas and the dough will rise to its maximum height.

Baking: If you are using the NORMAL or REGULAR program, the bread will be baked to perfection. If you are making bread that contains too much sugar in the recipe, it may cause the bread to overbake. Set your machine on the lightest setting.

Keep Warm: If you are unable to remove the baked bread immediately after baking, the Bread Machine will keep the loaf warm as to reduce the effects of the condensation that will form between the loaf and the pan. Nevertheless, always remove the bread as quickly as possible after the baking cycle is completed.

INSERTING AND REMOVING THE BREAD PAN

1. Before using the Bread Machine for the first time, be certain to wash the bread pan and dough blade with warm water and mild dish-washing liquid. Towel dry. Never put the bread pan and blade into the dishwasher.
2. All mixing, kneading, rising and baking (when appropriate) take place in the bread pan. The pan is covered with a non-stick coating which will scratch if not treated and cared for properly. Clean and treat the pan as you would a non-stick frying pan.
3. To reinsert the pan, place over the locking mechanism located on the bottom of the baking compartment. Push down and twist clockwise until locked into position. To remove the pan, twist counter-clockwise and lift up.
4. Remember to insert the kneading blade on the shaft located in the bread pan before adding your ingredients.
5. Since the bread pan will be hot after the baking cycle, always use a kitchen mitt or pot holder when removing it.
6. To remove the bread from the pan (for model #ABM4100T, first remove the dough hook), invert upside down and gently shake up and down until the loaf slides out. If the bread does not come out of the pan easily, use a non-metallic kitchen utensil to pry it out.

CLEANING INSTRUCTIONS

If taken care of properly, your Welbilt® Bread Machine will provide you with many years of use and hundreds of loaves of delicious bread.

1. After each use, unplug the Bread Machine. Let the unit cool down to room temperature. Wipe out the baking compartment and the inner lid with a clean, damp cloth or sponge.
2. Remove the kneading blade from the pan. It may be necessary to fill the pan with water in order to loosen the blade from the shaft. Clean the pan and blade with warm water and mild dishwashing liquid. Never use abrasive or strong household cleaners since they will damage the non-stick finish. Towel dry.
3. Wipe down the cabinet of the Bread Machine with a clean, damp cloth or sponge. Towel dry.

INSIDER'S GUIDE TO EASY BAKING

Your Welbilt Bread Machine produces delicious baked goods with ease. This marvelous machine asks only that you carefully follow the recipe instructions! In basic cooking, normally "a pinch of this and a dash of that" is fine, but not for automatic bread machines. Using an auto-matic Bread Machine requires you accurately measure each ingredient (especially yeast and water) for best results. For best results, have your ingredients at room temperature 65° to 85°F, unless otherwise specified.

TRADITIONAL YEAST BREADS

The mention of fresh-baked bread evokes different memories for different people. But, there's one thing certain about all good yeast breads. They're always moist and meaty. Pinch or squeeze a slice of good bread. It will, slowly but surely, resume its original shape.

PREPARATION FOR GOOD RESULTS

Your Bread Machine produces satisfying results if you carefully follow directions and use the indicated ingredients.

Bread Flour: Now available in most supermarkets in 5 lb. bags, bread flour is higher in gluten than unbleached all-purpose flour. Gluten, a natural protein found in wheat flour, makes dough elastic when efficiently kneaded. This high gluten content produces higher volume loaves. Bread flour is the flour of choice when working with yeast and whole grain breads, unless otherwise specified. Never use flour that has been sitting in an open bag or container for more than six months or during an extended period of high humidity.

Estimated Equivalents

2 cups flour = 1 lb. bread

3 cups flour = 1½ lbs. bread

4 cups flour = 2 lbs. bread

Active Dry Yeast: Use only dry yeast – never compressed cake yeast. The amount given in the recipe is for active dry yeast. For conversion to fast-rising yeast, see chart below. Check its expiration date. Yeast is the leavening agent that causes dough to expand or “rise.” Liquid and warmth bring yeast back to life. When reactivated, yeast releases carbon dioxide bubbles that make well-kneaded dough rise.

If the yeast is close to the expiration date or the expiration date has passed, it should be discarded and fresh yeast purchased. Never use yeast from torn or previously opened packets. If using bulk yeast from a jar, always store properly according to the manufacturer's instructions on the package. *To check if your yeast is still good, proof your yeast.*

HOW TO PROOF YEAST FOR BREAD MACHINES

Start with a clear plastic or glass 1-cup measure. Pour in $\frac{1}{2}$ cup of water (110°-115°F). Add 1 teaspoon sugar and stir until dissolved. Next, add $2\frac{1}{4}$ teaspoons active dry yeast (one $\frac{1}{4}$ -ounce package) and stir. Set aside for 10 minutes to ferment. After 10 minutes, a crest of foam similar to root beer foam should have developed with the crest at the rim of the cup. If foam crests below rim, discard and buy fresh yeast for your Bread Machine.

Conversion Chart for Fast-Rising Yeast

1 $\frac{1}{2}$ teaspoons active dry yeast	=	1	teaspoon fast-rising yeast
2 $\frac{1}{2}$ teaspoons active dry yeast	=	1 $\frac{1}{2}$ teaspoons	fast-rising yeast
1	tablespoon active dry yeast	=	2 $\frac{1}{4}$ teaspoons of fast-rising yeast

EXCEPTION: In the ABM4100T, 1 $\frac{1}{2}$ teaspoons active dry yeast equals 1 $\frac{1}{2}$ teaspoons fast-rising yeast.

Sweetener and Salt: Never eliminate the sweetener in the recipe. Yeast uses it as energy on which to grow. Salt also plays an important role. It helps stabilize the rising process so that the dough rises evenly.

(continued next page)

Non-fat Dry Milk: Always use non-fat dry milk to prevent spoilage and to maintain the proper balance of wet to dry ingredients. If there are eggs in the recipe, never use the programmable timer in order to prevent spoilage.

Shortening: Always use stick butter/oil. It has less moisture than tub butter and less air than whipped. *Measure:* 1 stick = $\frac{1}{2}$ cup = 8 tablespoons.

Water and Liquids: Water and all other liquid ingredients should be at approximately 80°F. If you do not have a thermometer to measure temperature, use room temperature liquids.

HOW TO JUDGE IF THINGS ARE GOING WELL

Ingredients for Success

Always measure the ingredients carefully using U.S. standard measuring cups and spoons. Kitchen flatware and coffee cups vary in size and should never be used. All ingredients should be at room temperature unless otherwise noted in recipe. Since you will be using all natural ingredients to make your homemade bread, the quality of the ingredients is important. Since flour is milled from wheat, and other grains, the quality and make up of the flour will vary from crop to crop, from year to year even though the mills make every attempt to blend the grains for proper consistency.

Nevertheless, you may see that your bread does not come out the same when using flour from a different brand. If this is the case, we suggest that you experiment. (*If, for example, the bread made from brand "X" bread flour does not provide a satisfactory loaf of bread, try another brand. The same applies to yeast.*) Some packages of yeast will provide greater rising activity than others. If your bread does not rise well, try another package of yeast or another brand. We have also seen that certain brands of yeast work better with certain brands of flour. (*Experiment until you find the combination that works best for you.*)

Although the quality of the bread should not be affected by the type/source of water used, extremely hard or soft water can determine whether a loaf of bread is good or bad. If your water falls in this category, only make bread using bottled spring water with a low mineral content or try to substitute the water with low fat milk.

Dough Development

After the first kneading cycle, the ball of kneaded dough should be smooth and elastic. The top of the dough should be slightly sticky and should begin to fill out on the bottom of the pan while rising. If the dough appears stiff and lumpy, it is too dry. Dough that is too dry can result in short loaves of bread which appear overbaked.

HINT: Due to varying flour conditions, the dough may appear too dry after kneading the first couple of minutes. If this is the case, press STOP/RESET. PRESS START and add additional water, a tablespoon at a time, until the dough appears elastic. Do not exceed the following recommendations for:

3 Cup Flour Capacity:

No more than 2 tablespoons additional water.

4 Cup Flour Capacity:

No more than 3 tablespoons additional water.

When measuring flour never scoop it out of the bag or the canister with the measuring cup. Always spoon the flour into the cup. Insert a clean kitchen knife into the flour a couple of times to eliminate clumps or air pockets. Level off the top of the cup with the knife. Never pack the flour down.

If the dough appears to be very loose and sticky, it is too moist. You can overcome this problem by making sure you measure the ingredients properly or add less water (approximately one to two tablespoons less) to compensate for a higher than normal moisture content of the flour. (*Dough that is too moist can result in over-risen, collapsed, wrinkled loaves of bread.*)

Baking

Always set your Bread Machine on the proper baking setting as specified in the recipe. If the bread bakes too dark, try a lighter setting. If the bread continues to bake too dark the dough may be too dry inhibiting the bread to rise properly. *(Try adding one to two tablespoons of additional water for better baking results.)* Too much sugar in a recipe may also cause bread to overbake. The same is true with dried fruits. Try cutting down on the amount called for in the recipe by 25 to 50%.

Do not use your Bread Machine if the room temperature is lower than 65°F since the dough will not rise well and the loaves will be short. If the ambient temperature is higher than 85°F the dough can over-rise and the bread can possibly collapse or wrinkle during baking and the crumb texture will be coarse.

THE FINISHED PRODUCT

For a crisp, crunch crust, always remove the bread from the Bread Machine after the baking cycle. Remove from the pan and let cool on a wire rack in a draft free location. For a softer crust, immediately place the baked loaf of bread in an open plastic bag or loosely wrap in foil.

The size of the baked loaf of bread will vary from loaf to loaf due to ingredients and ambient condition. Nevertheless, the general rule is that the bread size should be near the top of the pan to 1-inch below.

Recipes



BASIC WHITE BREAD



Everyone's badmouthing white bread these days. Sometimes, however, only white bread will do. So we developed a recipe to ease your guilt. It's moist and meaty and has no preservatives.

Add ingredients in the order listed. All ingredients must be at room temperature.

	<u>1 lb. loaf</u>	<u>1½ lb. loaf</u>
<i>water</i>	¾ cup + 1 TBL	1 cup + 2 TBL
<i>butter/oil</i>	4 teaspoons	2 tablespoons
<i>nonfat dry milk</i>	4 teaspoons	2 tablespoons
<i>salt</i>	1 teaspoon	1½ teaspoons
<i>granulated sugar</i>	4 teaspoons	2 tablespoons
<i>bread flour</i>	2¼ cups	3 cups
<i>active dry yeast</i>	1½ teaspoons	2¼ teaspoons

AUTOMATIC BREAD PROGRAM

- Press SELECT to #01, #02 (1½ lb. NORMAL or DARK) or #03 or #04 (1 lb. NORMAL or DARK) or press #07 for RAPID cycle.
- Press START.
- After baking, press STOP. Remove bread from Bread Machine and baking pan. Cool on rack.

BASIC WHITE BREAD VARIATIONS

Let your imagination take wing when baking variations of Basic White Bread. Please note that when using a flavoring high in salt, such as dried soup/dip mix, eliminate salt in the basic recipe.

After adding nonfat dry milk for Basic White Bread, add one or more of flavorings. Adjust the amount according to taste, but please don't exceed the maximum amount stated. Next add the salt, sugar, bread flour and yeast. Continue with directions for Automatic Bread Program.

- Nuts*: chopped walnuts, pecans, peanuts — 1 lb. loaf use $\frac{1}{4}$ cup; $1\frac{1}{2}$ lb. loaf use $\frac{1}{2}$ cup; 2 lb. loaf use $\frac{3}{4}$ cup.
- Dried Herbs*: basil leaves, oregano leaves, Italian spices, fine herbs, etc. — 2 to 3 teaspoons.
- Spices*: powdered or ground spices (onion powder, cardamon, etc.) — use 2 to 3 teaspoons. Do not use garlic or cinnamon as they will be the cause of a shorter loaf.
- Dried Fruit*: raisins, chopped prunes, chopped dates, craisins — 1 lb. loaf use $\frac{1}{3}$ cup; $1\frac{1}{2}$ lb. loaf use $\frac{1}{2}$ cup; 2 lb. loaf use $\frac{2}{3}$ cup. (Do not use apricots as they will cause a shorter loaf.) *Reduce the sugar in the recipe for 1 lb. loaf to 2 teaspoons; $1\frac{1}{2}$ lb. loaf to 1 tablespoon; 2 lb. loaf to 2 tablespoons.*
- Grated or Shredded Cheese*: Parmesan, Romano, Swiss, Cheddar Cheese — 1 lb. loaf use 1 cup; $1\frac{1}{2}$ lb. loaf use $1\frac{1}{2}$ cups; 2 lb. loaf use 2 cups. *Reduce the water in the recipe for 1 lb. loaf by 1 tablespoon; $1\frac{1}{2}$ lb. loaf by 2 tablespoons; 2 lb. loaf by 3 tablespoons.*

NOTE: Seed such as sunflower, poppy or sesame are not recommended for this recipe. The amount of fat in them will throw off the recipe.

RYE BREAD

Chewy Rye Bread is the ultimate deli sandwich bread. Since rye flour has very little gluten, it is to be mixed with bread flour so that it rises properly. The caraway seeds are what give this bread its characteristic flavor.

Add ingredients in the order listed (except caraway seeds). All ingredients must be at room temperature.

	<u>1 lb. loaf</u>	<u>1½ lb. loaf</u>
<i>water</i>	¾ cup + 1 TBL	1 cup + 2 TBL
<i>butter/oil</i>	4 teaspoons	2 tablespoons
<i>nonfat dry milk</i>	1 tablespoon	2 tablespoons
<i>salt</i>	1 teaspoon	1½ teaspoons
<i>brown sugar</i>	4 teaspoons	2 tablespoons
<i>bread flour</i>	1½ cups	2 cups
<i>medium rye flour</i>	¾ cup	1 cup
<i>active dry yeast</i>	1½ teaspoons	2¼ teaspoons
<i>caraway seeds</i>	2 teaspoons	1 tablespoon

AUTOMATIC BREAD PROGRAM

- Press SELECT to #01, #02 (1½ lb. NORMAL or DARK) or #03 or #04 (1 lb. NORMAL or DARK) or press #07 for RAPID cycle.
- Press START. When the Bread Machine beeps before the end of the last kneading, add the caraway seed.
- After baking, press STOP. Remove bread from Bread Machine and baking pan. Cool on rack.

ONION BREAD

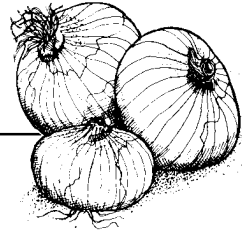

The humble onion is found in every cuisine. Its most famous role is in French onion soup. Today dried onion soup mix is added to recipes more often than served as soup. So, we tried it in yeast dough. The resulting bread satisfies the most extreme craving for onions.

Add ingredients in the order listed (except dry onion mix). All ingredients must be at room temperature.

	<u>1 lb. loaf</u>	<u>1½ lb. loaf</u>
<i>water</i>	$\frac{7}{8}$ cup	1 cup + 2 TBL
<i>butter/oil</i>	4 teaspoons	2 tablespoons
<i>nonfat dry milk</i>	4 teaspoons	2 tablespoons
<i>granulated sugar</i>	2 teaspoons	1 tablespoon
<i>bread flour</i>	$2\frac{1}{4}$ cups	3 cups
<i>active dry yeast</i>	$1\frac{1}{2}$ teaspoons	$2\frac{1}{4}$ teaspoons
<i>dry onion soup mix</i>	4 teaspoons	2 tablespoons

AUTOMATIC BREAD PROGRAM

- Press SELECT to #01, #02 (1½ lb. NORMAL or DARK) or #03 or #04 (1 lb. NORMAL or DARK) or press #07 for RAPID cycle.
- Press START. When the Bread Machine beeps before the end of the last kneading, add the dry onion mix.
- After baking, press STOP. Remove bread from Bread Machine and baking pan. Cool on rack.

CINNAMON NUT RAISIN BREAD

Remember when Mom fixed raisin toast for breakfast or a snack? Well, we've gone a little further by adding cinnamon, chopped nuts and dark brown sugar to our raisin bread.

Add ingredients in the order listed (except raisins and nuts). All ingredients must be at room temperature.

	<u>1 lb. loaf</u>	<u>1½ lb. loaf</u>
<i>water</i>	$\frac{3}{4}$ cup + 1 TBL	1 cup + 2 TBL
<i>butter/oil</i>	4 teaspoons	2 tablespoons
<i>nonfat dry milk</i>	4 teaspoons	2 tablespoons
<i>salt</i>	1 teaspoon	1½ teaspoons
<i>dark brown sugar</i>	2 teaspoons	1 tablespoons
<i>cinnamon</i>	$\frac{1}{2}$ teaspoon	$\frac{3}{4}$ teaspoon
<i>bread flour</i>	2¼ cups	3 cups
<i>active dry yeast</i>	1½ teaspoons	2¼ teaspoons
<i>raisins</i>	$\frac{1}{3}$ cup	$\frac{1}{2}$ cup
<i>chopped nuts</i>	$\frac{1}{3}$ cup	$\frac{1}{2}$ cup

AUTOMATIC BREAD PROGRAM

- Press SELECT to #01, #02 (1½ lb. NORMAL or DARK) or #03 or #04 (1 lb. NORMAL or DARK) or press #07 for RAPID cycle.
- Press START. When the Bread Machine beeps before the end of the last kneading, add the raisins and chopped nuts.
- After baking, press STOP. Remove bread from Bread Machine and baking pan. Cool on rack.

EGG BREAD

Our Egg Bread is toothsome yet light. Maybe one morning you'll be lucky and find some leftover Egg Bread in the kitchen to make some of the World's Best French toast!

Add ingredients in the order listed. All ingredients must be at room temperature.

	<u>1 lb. loaf</u>	<u>1½ lb. loaf</u>
<i>water</i>	$\frac{3}{4}$ cup	1 cup
<i>butter/oil</i>	1 tablespoon	2 tablespoons
<i>egg yolk</i>	1 large	2 large
<i>nonfat dry milk</i>	1 tablespoon	2 tablespoons
<i>salt</i>	1 teaspoon	$1\frac{1}{2}$ teaspoons
<i>granulated sugar</i>	1 tablespoon	2 tablespoons
<i>bread flour</i>	$2\frac{1}{4}$ cups	3 cups
<i>active dry yeast</i>	$1\frac{1}{2}$ teaspoons	$2\frac{1}{4}$ teaspoons

AUTOMATIC BREAD PROGRAM

- Press SELECT to #01, #02 (1½ lb. NORMAL or DARK) or #03 or #04 (1 lb. NORMAL or DARK) or press #07 for RAPID cycle.
- Press START.
- After baking, press STOP. Remove bread from Bread Machine and baking pan. Cool on rack.

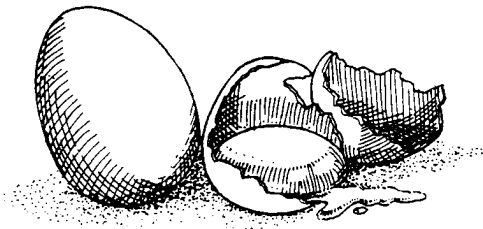

CHEVRE CRACKED-PEPPER BREAD

What is all this fuss about black pepper? While some people cough and sneeze as fashionable waiters grind it onto salads, other diners cry, "More, more!" So, here's a bread that will knock your socks off. Not only is it chock full of this current star of spices, but chevre adds a pungent twist.

Add ingredients in the order listed (except black pepper). All ingredients must be at room temperature.

	<u>1 lb. loaf</u>	<u>1½ lb. loaf</u>
<i>water</i>	¾ cup	1 cup
<i>soft goat cheese</i>	1½ ounces	2¼ ounces
<i>nonfat dry milk</i>	4 teaspoons	2 tablespoons
<i>salt</i>	¾ teaspoon	1 teaspoon
<i>granulated sugar</i>	4 teaspoons	2 tablespoons
<i>bread flour</i>	2¼ cups	3 cups
<i>active dry yeast</i>	1½ teaspoons	2¼ teaspoons
<i>cracked black pepper</i>	2 teaspoons	1 tablespoon

AUTOMATIC BREAD PROGRAM

- Press SELECT to #01, #02 (1½ lb. NORMAL or DARK) or #03 or #04 (1 lb. NORMAL or DARK) or press #07 for RAPID cycle.
- Press START. When the Bread Machine beeps before the end of the last kneading, add the black pepper.
- After baking, press STOP. Remove bread from Bread Machine and baking pan. Cool on rack.



CHEDDAR BACON BREAD

When we set out to develop a cheese bread for the Bread Machine, the decision was to go whole hog and use bacon as well. What a dynamite combo! If you're watching cholesterol, this bread is not for you . . . well, maybe one bite would be okay.

Add ingredients in the order listed (except bacon and cheddar cheese). All ingredients must be at room temperature.

	<u>1 lb. loaf</u>	<u>1½ lb. loaf</u>
<i>water</i>	½ cup + 1 TBL	⅞ cup
<i>nonfat dry milk</i>	4 teaspoons	2 tablespoons
<i>salt</i>	¾ teaspoon	1 teaspoon
<i>granulated sugar</i>	4 teaspoons	2 tablespoons
<i>bread flour</i>	2 cups	3 cups
<i>active dry yeast</i>	1½ teaspoons	2¼ teaspoons
<i>sharp cheddar cheese, shredded</i>	1 cup	1½ cups
<i>bacon (crisp fried & crumbled)</i>	4 slices	5 to 6 slices

AUTOMATIC BREAD PROGRAM

- Press SELECT to #01, #02 (1½ lb. NORMAL or DARK) or #03 or #04 (1 lb. NORMAL or DARK) or press #07 for RAPID cycle.
- Press START. When the Bread Machine beeps before the end of the last kneading, add the crumbled bacon and cheddar cheese.
- After baking, press STOP. Remove bread from Bread Machine and baking pan. Cool on rack.

MAPLE WALNUT WHEAT BREAD



One of our favorite restaurants makes all its own baked goods. At dinner, they feature a homemade loaf with a tantalizing flavor. We finally discovered it's maple. After dining in that exceptional restaurant many times, this bread has become a must. We have recreated it for you.

Add ingredients in the order listed (except walnuts). All ingredients must be at room temperature.

	<u>1 lb. loaf</u>	<u>1½ lb. loaf</u>
<i>water</i>	¾ cup	1 cup
<i>butter/oil</i>	4 teaspoons	2 tablespoons
<i>100% pure maple syrup</i>	4 teaspoons	2 tablespoons
<i>maple flavor</i>	¾ teaspoon	1 teaspoon
<i>buttermilk powder</i>	4 teaspoons	2 tablespoons
<i>salt</i>	1 teaspoon	1½ teaspoons
<i>bread flour</i>	1½ cups	2 cups
<i>whole wheat flour</i>	¾ cup	1 cup
<i>active dry yeast</i>	1½ teaspoons	2¼ teaspoons
<i>chopped walnuts</i>	⅓ cup	½ cup

AUTOMATIC BREAD PROGRAM

- Press SELECT to #01, #02 (1½ lb. NORMAL or DARK) or #03 or #04 (1 lb. NORMAL or DARK) or press #07 for RAPID cycle.
- Press START. When the Bread Machine beeps before the end of the last kneading, add the chopped walnuts.
- After baking, press STOP. Remove bread from Bread Machine and baking pan. Cool on rack.

COUNTRY RAISIN BREAD

A moist, buttery egg bread chock full of raisins and reminiscent of breakfast at Grandma's!

Add ingredients in the order listed (except raisins). All ingredients must be at room temperature.

	<u>1 lb. loaf</u>	<u>1½ lb. loaf</u>
<i>water</i>	¾ cup	1 cup + 2 TBL
<i>butter/oil</i>	2 tablespoons	3 tablespoons
<i>egg yolk</i>	1 large	1 large
<i>nonfat dry milk</i>	1 tablespoon	4½ teaspoons
<i>salt</i>	½ teaspoon	¾ teaspoon
<i>granulated sugar</i>	1 tablespoon	4½ teaspoons
<i>bread flour</i>	2 cups	3 cups
<i>active dry yeast</i>	1½ teaspoons	2¼ teaspoons
<i>raisins</i>	¼ cup	⅓ cup

AUTOMATIC BREAD PROGRAM

- Press SELECT to #01, #02 (1½ lb. NORMAL or DARK) or #03 or #04 (1 lb. NORMAL or DARK) or press #07 for RAPID cycle.
- Press START. When the Bread Machine beeps before the end of the last kneading, add the raisins.
- After baking, press STOP. Remove bread from Bread Machine and baking pan. Cool on rack.

100% WHOLE WHEAT BREAD

Just about everyone is concerned about adding more fiber to their diet. Well, our 100% Whole Wheat Bread adds a substantial amount of nutritious, full-flavored fiber.

Add ingredients in the order listed. All ingredients must be at room temperature.

<i>water</i>	1 cup + 2 TBL
<i>butter/oil</i>	1 tablespoon
<i>honey</i>	¼ cup
<i>nonfat dry milk</i>	2 tablespoons
<i>salt</i>	1 teaspoon
<i>whole wheat flour</i>	3 cups
<i>active dry yeast</i>	1 tablespoon

AUTOMATIC BREAD PROGRAM

- Press SELECT to #06 (WHOLE WHEAT 1 & 1½ lb.).
- Press START.
- After baking, press STOP. Remove bread from Bread Machine and baking pan. Cool on rack.

SUNFLOWER OATMEAL BREAD

This one is definitely from the Heartland! Crunchy sunflower seeds in a whole wheat, oatmeal and honey base evoke visions of fields ripe with golden grains.

Add ingredients in the order listed (except sunflower seeds). All ingredients must be at room temperature, unless otherwise noted.

<i>water</i>	1¼ cups
<i>honey</i>	3 tablespoons
<i>nonfat dry milk</i>	3 tablespoons
<i>salt</i>	1 teaspoon
<i>uncooked oatmeal</i>	½ cup
<i>bread flour</i>	1 cup
<i>whole wheat flour</i>	2 cups
<i>active dry yeast</i>	1 tablespoon
<i>sunflower seeds, unsalted & hulled</i>	⅓ cup

AUTOMATIC BREAD PROGRAM

- Press SELECT to #06 (WHOLE WHEAT 1 & 1½ lb.).
- Press START. When the Bread Machine beeps before the end of the last kneading, add the sunflower seeds.
- After baking, press STOP. Remove bread from Bread Machine and baking pan. Cool on rack.



HONEY OATS 'N' BARLEY BREAD

Studies indicate that oat bran is even more beneficial than healthful wheat bran. So, we couldn't resist adding some to one of our whole grain breads. Lots of oatmeal plus crunchy barley make this bread a sure hit.

Add ingredients in the order listed. All ingredients must be at room temperature, unless otherwise noted.

<i>water</i>	1 cup
<i>butter/oil</i>	2 tablespoons
<i>honey</i>	3 tablespoons
<i>salt</i>	1 teaspoon
<i>uncooked oatmeal</i>	1/2 cup
<i>oat bran</i>	1/4 cup
<i>barley</i>	3 tablespoons
<i>bread flour</i>	2 cups
<i>whole wheat flour</i>	1/2 cup
<i>active dry yeast</i>	2 1/4 teaspoons

AUTOMATIC BREAD PROGRAM

- Press SELECT to #06 (WHOLE WHEAT 1 & 1 1/2 lb.).
- Press START.
- After baking, press STOP. Remove bread from Bread Machine and baking pan. Cool on rack.

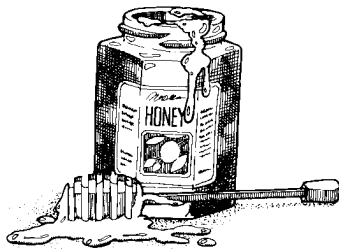

DARK PUMPERNICKEL BREAD

There's something about pumpernickel that begs for a big pot of soup and a roaring fire. Perhaps its darkness recalls winter nights in the Slavic countries of its origins.

Add ingredients in the order listed (except chocolate). All ingredients must be at room temperature, unless otherwise noted.

<i>water</i>	¼ cup + 2 TBL
<i>butter/oil</i>	1 tablespoon
<i>dark molasses</i>	¼ cup
<i>milk</i>	½ cup
<i>salt</i>	½ teaspoon
<i>onion powder</i>	1 teaspoon
<i>bread flour</i>	2 cups
<i>medium rye flour</i>	1 cup
<i>active dry yeast</i>	1 tablespoon
<i>unsweetened chocolate, melted</i>	1 ounce

AUTOMATIC BREAD PROGRAM

- Press SELECT to #06 (WHOLE WHEAT 1 & 1½ lb.).
- Press START. When the Bread Machine beeps before the end of the last kneading, add the melted unsweetened chocolate.
- After baking, press STOP. Remove bread from Bread Machine and baking pan. Cool on rack.

TRIPLE WHEAT BREAD

Now, if you thought our 100% Whole Wheat Bread was good, wait until you try this one. Triple wheat, triple treat! Whole wheat flour, wheat germ and wheat bran plus dark molasses create a loaf brimming with fiber.

Add ingredients in the order listed. All ingredients must be at room temperature, unless otherwise noted.

<i>water</i>	1¼ cups
<i>butter/oil</i>	2 tablespoons
<i>dark molasses</i>	3 tablespoons
<i>nonfat dry milk</i>	2 tablespoons
<i>salt</i>	1 teaspoon
<i>cracked wheat</i>	¼ cup
<i>wheat bran</i>	½ cup
<i>wheat germ</i>	½ cup
<i>bread flour</i>	1½ cups
<i>whole wheat flour</i>	1½ cups
<i>active dry yeast</i>	1 tablespoon

AUTOMATIC BREAD PROGRAM

- Press SELECT to #06 (WHOLE WHEAT 1 & 1½ lb.).
- Press START.
- After baking, press STOP. Remove bread from Bread Machine and baking pan. Cool on rack.

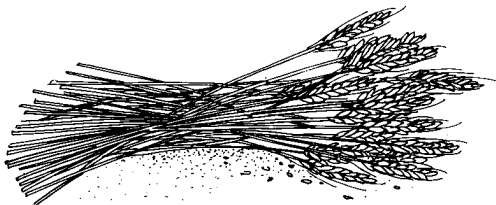

SHREDDED WHEAT BREAD

Connoisseurs of shredded wheat know their favorite cereal has no added sugar or salt. It's just pure, wholesome goodness in a delightfully crunchy form. The idea of basing a bread on breakfast cereal was intriguing, as is the spicy hint imparted by light molasses.

Add ingredients in the order listed. All ingredients must be at room temperature, unless otherwise noted.

<i>water</i>	1 cup
<i>butter/oil</i>	3 tablespoons
<i>light molasses</i>	3 tablespoons
<i>salt</i>	1 teaspoon
<i>mini-shredded wheat</i>	1 cup
<i>bread flour</i>	1 cup
<i>whole wheat flour</i>	2 cups
<i>active dry yeast</i>	1 tablespoon

AUTOMATIC BREAD PROGRAM

- Press SELECT to #06 (WHOLE WHEAT 1 & 1½ lb.).
- Press START.
- After baking, press STOP. Remove bread from Bread Machine and baking pan. Cool on rack.

PIZZA DOUGH

It's time to change the timeworn phrase "As American as apple pie" to "As American as pizza pie!" Our country is so taken with pizza that entire restaurant chains are devoted to it. They even promise to deliver hot on the spot, or your next one's free. Why bother with carryout pizza when you can make your own in about the time it takes to have one delivered?

Add ingredients in the order listed. All ingredients must be at room temperature.

- 3/4 cup water*
- 2 tablespoons olive oil*
- 1 teaspoon salt*
- 2 1/2 cups bread flour*
- 1 3/4 teaspoons active dry yeast*

DOUGH PROGRAM

- Press SELECT to #08 (DOUGH).
- Press START.
- At the end of the program press STOP. Remove dough from the Bread Machine. Dough is ready for hand shaping, rising and baking.

PIZZA DOUGH VARIATIONS

HAND-SHAPING

- Place dough on a lightly floured surface. Cover dough with a clean cloth, and let dough rest for 10 minutes. Cut into halves. Press each evenly into a lightly greased 12-inch pizza pan. Prick dough all over with a fork.
- Bake in a 400°F preheated oven for 12 to 15 minutes, until crust is lightly browned. Yield: 2 12-inch crusts.
- Remove from oven and spread/sprinkle crust with your favorite pizza toppings. Return to oven for 10 to 15 minutes, until toppings are bubbling and/or melted.

VARIATIONS

- Substitute $\frac{1}{2}$ to 1 cup whole wheat flour for same amount of bread flour.
- Add 1 tablespoon crushed herbs (oregano, Italian spices, etc.) to ingredients just before adding oil.
- Add 1 cup grated or shredded cheese (grated Parmesan, Romano, shredded Cheddar, pepper jack) to ingredients just before adding oil.

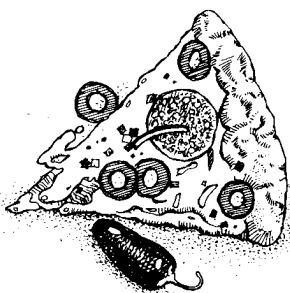

BAGELS

There's nothing in this world like a chewy bagel – smothered with cream cheese and lavished with lox. Bagels join the melting pot of ethnic foods Americans call their own. Yet they remain unique in the realm of yeast breads. A lot of kneading makes them chewy, and boiling them in sugar gives them their shine. Pile on the seeds, salt or onions – and mazeltov!

Add ingredients in the order listed. All ingredients must be at room temperature.

- 1 *cup water*
- 1½ *teaspoons salt*
- 2 *tablespoons granulated sugar*
- 3 *cups bread flour*
- 2¼ *teaspoons active dry yeast*

DOUGH PROGRAM

- Press SELECT to #08 (DOUGH).
- Press START.
- At the end of the program press STOP. Remove dough from the Bread Machine. Dough is ready for hand shaping, rising and baking.

BAGELS (contd.)

HAND-SHAPING

- Bring 3 quarts water to boil in a large pot. Stir in 3 tablespoons of sugar.
- Place dough on a lightly floured surface. Let dough rest for 5 minutes.
- Cut dough into 9 equal pieces. Roll each into a smooth ball. Flatten balls, and poke a hole in the middle of each with your thumb. Next twirl the dough to enlarge the hole and even out the dough around it. Cover bagels with a clean cloth, and let rest for 10 minutes.
- With a large metal spatula, carefully transfer bagels to boiling water, three at a time. Let boil for 1 minute, turning bagels over midway. Remove bagels from water with a slotted spoon and drain briefly on a clean towel. Transfer drained bagels to baking sheets sprinkled with corn meal, four to five bagels per sheet.
- If desired, glaze tops of bagels with *egg white* and sprinkle with *poppy or sesame seeds, coarse salt and/or reconstituted dry onions*. Bake bagels in 375°F preheated oven for 20 to 25 minutes, until well-browned. Yield: 9 bagels.



FRENCH BREAD

Have you ever noticed that the French have a flair for the finer things in life? This is especially true when it comes to bread!

Add ingredients in the order listed. All ingredients must be at room temperature.

- 1 *cup + 2 tablespoons water*
- 1 *teaspoon salt*
- 2 *teaspoons granulated sugar*
- 3 *cups bread flour*
- 2 *teaspoons active dry yeast*

DOUGH PROGRAM

- Press SELECT to #08 (DOUGH).
- Press START.
- At the end of the program press STOP. Remove dough from the Bread Machine. Dough is ready for hand shaping, rising and baking.

FRENCH BREAD (cont'd.)

HAND-SHAPING

- Place dough on a lightly floured surface. Let dough rest for 5 minutes.
- Cut dough into halves. Roll each portion in a long rope and place in trough of a lightly greased, double-trough baguette pan (maximum 3-inch wide trough).
- Glaze each baguette with *egg white*. Slash 5 times diagonally with a very sharp knife or a pair of scissors. Place in a warm, draft-free spot to rise until doubled in size, about 45 to 60 minutes.
- Glaze unslashed portions again with *egg white*. Bake in a 400°F preheated oven for 25 to 30 minutes, until deep brown. Yield: 2 baguettes.

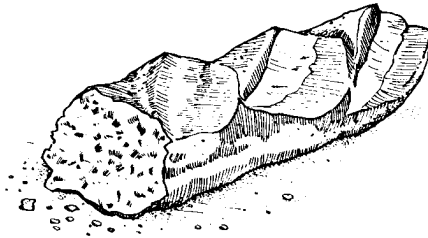

CHALLAH

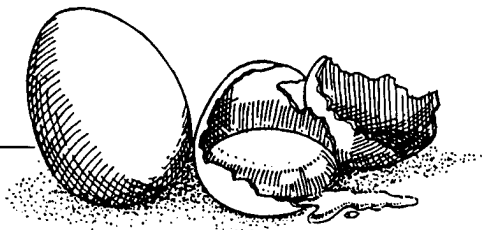

The traditional Jewish bread, Challah, is a delicious braided version of our Egg Bread. Covered with poppy or sesame seeds, this braided bread is great for sandwiches.

Prepare one recipe for the 1 lb. Egg Bread (see "Contents" for page) by using those ingredients for the *dough program* listed below. Add ingredients in the order listed. All ingredients must be at room temperature.

Prepare and Reserve:

1 large egg beaten with 1 teaspoon water

Optional Toppings:

1 teaspoon poppy or sesame seeds

DOUGH PROGRAM

- Press SELECT to #08 (DOUGH).
- Press START.
- At the end of the program press STOP. Remove dough from the Bread Machine. Dough is ready for hand shaping, rising and baking.

HAND-SHAPING

- Place dough on a lightly floured surface. Let dough rest for 5 minutes.
- Divide dough into thirds. Roll each portion into a 14-inch rope. Place ropes side-by-side on a greased baking sheet. Braid ropes and tuck ends under securely. Cover with a clean cloth. Place in a warm, draft-free spot to rise until doubled in size, about 45 to 60 minutes.
- Brush braid with *egg wash*. Optional Topping: Sprinkle with *poppy or sesame seeds*. Bake in 375°F preheated oven for 25 to 30 minutes, until deep golden brown.

CINNAMON ROLLS

We have yet to meet a person who does not like cinnamon rolls. The recipe that follows is simple to prepare and is not overly sweet.

Prepare one recipe for Holiday Bread (see "Contents" for page). Do not add raisins. Use *hand-shaping* technique shown on this page.

Brown Sugar – Cinnamon Filling:

- $\frac{1}{3}$ cup dark brown sugar
 - 2 teaspoons cinnamon
 - 2 tablespoons softened butter
- (Mix together to form a soft paste.)

Icing:

- 3 tablespoons softened butter
 - 2 teaspoons unbleached all-purpose flour
 - $\frac{1}{3}$ cup Confectioner's sugar
 - $\frac{1}{2}$ teaspoon vanilla extract
- (Blend all ingredients until smooth.)

HAND-SHAPING

- Place prepared dough on a lightly floured surface. Let dough rest for 5 minutes.
- With a lightly floured rolling pin, roll dough into a $\frac{1}{4}$ -inch thick rectangle. Square off edges. Spread evenly with *brown sugar-cinnamon filling*. Roll up lengthwise, jelly-roll fashion. Pinch edges together.
- Slice into 1-inch thick rounds. Place on a lightly greased baking sheet. Cover with a clean cloth. Place in a warm, draft-free spot to rise until doubled in size, about 1 hour.
- Bake in a 350°F preheated oven for 15 to 20 minutes, until golden brown. Remove and cool on a rack. When cooled to room temperature, drizzle with *icing*.

BREAD STICKS

Bread sticks are simple to make and fun to eat. They also make wonderful gifts for family and friends.

Prepare one recipe for Pizza Dough (see "Contents" for page). Use *hand-shaping* technique shown on this page.

Optional Toppings:

- 1 *large egg beaten with 1 teaspoon water*
- 2 *tablespoons finely grated Parmesan or sharp Cheddar Cheese*
- 1 *tablespoon seeds or herbs/spices*

HAND-SHAPING

- Place dough on a lightly floured surface. Let dough rest for 5 minutes.
- With a lightly floured rolling pin, roll dough into a $\frac{1}{4}$ -inch thick rectangle. Square off edges.
- Optional Toppings: Brush the surface with *egg wash*. Sprinkle lightly with grated Parmesan or Cheddar *cheese*, or desired *seeds, herbs or spices*.
- Cut into 8-inch long by $\frac{1}{4}$ -inch wide strips. Carefully place on a lightly greased baking sheet, allowing $\frac{1}{2}$ -inch between each bread stick.
- Bake in 375°F preheated oven for 15 to 20 minutes, until golden brown.

DINNER ROLLS

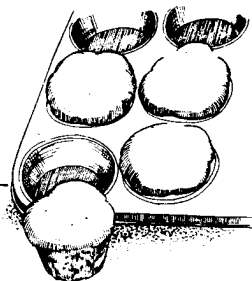

Dinner Rolls are remarkably light, moist and high in volume. Cottage cheese, adds protein!

Add ingredients in the order listed. All ingredients must be at room temperature.

- 3 to 6 teaspoons water
- 1 large egg
- 3 tablespoons honey
- 1½ cups cottage cheese, undrained
- 1½ teaspoons salt
- ½ teaspoon baking soda
- 3 cups whole wheat flour
- 2¼ teaspoons active dry yeast

DOUGH PROGRAM

- Press SELECT to #08 (DOUGH).
- Press START.
- At the end of the program press STOP. Remove dough from the Bread Machine. Dough is ready for hand shaping, rising and baking.

HAND-SHAPING

- Place dough on a lightly floured surface. Let dough rest for 5 minutes.
- Divide dough into 12 equal portions. Roll each piece into a ball, and place in a lightly greased 9-inch square baking pan. Cover with a clean cloth. Place in a warm, draft-free spot to rise until doubled in size, about 30 to 45 minutes.
- Glaze tops of rolls with *egg white*. Bake in 350°F preheated oven for 20 to 25 minutes, until tops are deeply browned.
Yield: 12 rolls.

HOLIDAY BREAD

Nothing is as festive as Holiday Bread – rich with raisins.

Add ingredients in the order listed (except for raisins). All ingredients must be at room temperature.

- $\frac{3}{4}$ cup water
- 2 tablespoons butter/oil
- 2 large eggs
- $1\frac{1}{2}$ teaspoons salt
- 2 tablespoons granulated sugar
- 3 cups bread flour
- $2\frac{1}{4}$ teaspoons active dry yeast

- $\frac{1}{2}$ cup raisins
(candied fruit may be substituted)

DOUGH PROGRAM

- Press SELECT to #08 (DOUGH).
- Press START. When the Bread Machine beeps before the end of the last kneading, add the raisins.
- At the end of the program press STOP. Remove dough from the Bread Machine. Dough is ready for hand shaping, rising and baking.

HAND-SHAPING

- Place dough on a lightly floured surface. Let dough rest for 5 minutes.
- Divide dough into thirds. Roll each portion into a 14-inch rope. Place ropes side-by-side on a greased baking sheet. Braid ropes and tuck ends under securely. Cover with a clean cloth. Place in a warm, draft-free spot to rise until doubled in size, about 45 to 60 minutes.
- Brush braid with *egg white*. Bake in 375°F preheated oven for 25 to 30 minutes, until deep golden brown.

CROISSANTS

Rumor has it that croissants were invented by the pastry chefs of Vienna to commemorate the expulsion of the Turks at the end of the Ottoman Empire. Whatever the reason, these flaky pastry rolls are international favorites the world over.

Add ingredients in the order listed. All ingredients must be at room temperature.

- 1 *cup water*
- 1½ *teaspoons butter*
- 1½ *teaspoons salt*
- 4½ *teaspoons granulated sugar*
- 3 *cups bread flour*
- 2¼ *teaspoons active dry yeast*

Prepare and Reserve:

- 1¾ *sticks chilled sweet butter cut into thin slices*
- 1 *large egg beaten with one teaspoon water*

DOUGH PROGRAM

- Press SELECT to #08 (DOUGH).
- Press START.
- At the end of the program press STOP. Remove dough from the Bread Machine. Dough is ready for hand shaping, rising and baking.



CROISSANTS (cont'd.)

HAND-SHAPING

- Place dough on a lightly floured surface. Let dough rest for 5 minutes.
- With a lightly floured rolling pin, roll dough into a ½-inch thick rectangle. Place the dough on a lightly greased baking sheet. Cover with a clean cloth, and place in the freezer for 1 hour.
- Remove the dough from the freezer. Place on a lightly floured surface and roll into a ¼-inch thick rectangle. Cover the dough with *chilled butter slices*. Fold the dough in half. Gently roll with rolling pin into a ¼-inch thick rectangle. Repeat folding process two more times. Place dough on previously greased baking sheet. Cover with a clean cloth, and place in refrigerator for 1 hour.
- Remove dough from refrigerator and place on lightly floured surface. Fold dough in half and roll into a ¼-inch thick rectangle. Repeat folding process two more times.
- Place dough on greased baking sheet, cover with cloth and return to refrigerator for 2 more hours. Remove dough from refrigerator and place on a lightly floured surface. Roll into a ⅛-inch rectangle. Square off edges.
- Cut dough in half lengthwise. Cut strips on an angle to form triangles. Brush lightly with *egg wash*.
- Roll triangles up from broad end to the point. Form into horn shape. Place croissants on lightly greased baking sheets. Cover with a clean cloth. Place in a warm, draft-free spot to rise until doubled in size, about 1 hour.
- Bake in 350°F preheated oven approximately 20 minutes, or until golden.

Practical Solutions to Easy Baking

The following tips will provide you with practical solutions to problems you might experience when using your Bread Machine. Read the Instruction Manual also. It will guide you to understand the usage of this appliance to achieve maximum enjoyment.

BASIC and WHOLE GRAIN YEAST BREADS

Problem	Cause	Solution
Dough/Bread did not rise enough.	Ingredients were not at room temperature.	Ingredients must be at room temperature unless otherwise noted.
	Ingredients were not placed in Bread Machine pan in the recipe's recommended order.	Place ingredients in Bread Machine pan in the recommended order.
	Yeast did not activate.	<p>Be certain yeast is fresh; check expiration date on back of package. Proof yeast as necessary. (See Insider's Guide.)</p> <p>Do not reduce amount of sugar or sweetener called for in recipe; do not use artificial sweeteners.</p> <p>Too much salt used, inhibiting dough to rise. Use amount specified in recipe.</p>
	Low gluten flour used.	Unless otherwise noted, always use bread flour.
	High altitude.	For every 1000 feet above 3000 feet sea level, reduce the water by 1 tablespoon, up to 4 tablespoons maximum.

Practical Solutions
BASIC and WHOLE GRAIN YEAST BREADS (cont'd.)

Problem	Cause	Solution
Bread collapses when baked.	Dough rose unevenly.	Make sure water is no warmer than room temperature (65° to 85°F.) Flour is very absorbent and absorbs moisture from air during periods of excessive humidity. If dough too sticky, bread can collapse. Reduce water or liquid in recipe by 2 to 3 tablespoons. Let appliance knead for 1 to 2 minutes; if dough appears too dry, add additional water 1 tablespoon at a time, up to 3 tablespoons.
Bread touches lid.	Weather very hot and/or humid.	Do not bake bread in Bread Machine until cooler and less humid; reduce yeast by 25 to 50%. If recipe calls for 1½ teaspoons, try 1¼ teaspoons down to 1 teaspoon.
Bread does not bake thoroughly.	Too much or wrong type of yeast was used.	Use specified amount of either active dry or fast-rising yeast.
	Ingredients were not measured properly.	Measure ingredients carefully. Use U.S. Standard measuring cups and spoons.
	Lid was up.	Do not open lid during final rising and baking cycle.
	Ambient temperature lower than 70°F.	Use appliance in warmer location.
Bread burns.	Baking temperature is too high.	Set Bread Machine on lower setting.
	Recipe has been modified.	Reduce amount of sweetener and shortening.

**Practical Solutions
HAND-SHAPED BREADS**

Problem	Cause	Solution
Dough does not stretch when rolled out or shaped.	Gluten needs to rest.	Cover dough with a clean cloth and let rest for 5 to 10 minutes before proceeding.
Bread browns too quickly.	Oven may not be calibrated properly.	Test oven temperature with an oven thermometer. If temperature is not the same as thermostat setting, have oven serviced.
	Changes in weather may affect moisture contents of ingredients.	Add an additional 1 to 2 tablespoons of water to recipe the next time bread is made. If bread continues to brown too quickly, tent a sheet of aluminum foil over bread or rolls to slow down browning process.

TROUBLE SHOOTING GUIDE FOR THE BREAD MACHINE

Q: My Bread Machine did not start when I pressed the START pad.

A: Your machine was not plugged into a 120 Volt, 60 Hz. Outlet capable of providing the proper watts of electricity.

Q: My Bread Machine blade turns slow and intermittently for the first minute.

A: After the pre-warming cycle, your bread machine will slowly and intermittently mix the ingredients for the first minute or so. After, the blade will turn quickly and begin to knead the dough into a smooth ball.

Q: I just used my machine and now it won't re-start.

A: Your machine has not cooled down sufficiently. Remove the baking pan and wait until your machine cools down. Once cooled, replace the baking pan and press START.

Q: My Bread Machine did not bake the bread after the last RISING cycle.

A: Make sure you've selected SWEET, WHOLE WHEAT or RAPID yeast breads. If you have chosen DOUGH, your machine will knead and rise the dough but will not bake the bread.

Q: My Bread Machine "beeps" at the end of the last kneading cycle.

A: Your machine will beep several times a few minutes before the end of the last kneading cycle. This is to let you know, this is the best time to add ingredients such as raisins, nuts, chocolate chips, poppy seeds, etc.

Q: My Bread Machine was accidentally unplugged from the power outlet during operation.

A: If there was an interruption in the power supply, the program was canceled. If the kneading cycle has begun, remove the old ingredients and start over adding new ingredients.

SPECIFICATIONS

MODEL: ABM3000

POWER REQUIREMENT: 120V, 60Hz.

POWER CONSUMPTION:

HEATER: 500 WATTS

MOTOR: 100 WATTS

WELBILT[®]

P. O. BOX 220709
Great Neck, N · Y · 11021