

# **CONTENTS**

**BEFORE USING THE WASHING MACHINE**

**PRECAUTIONS AND GENERAL RECOMMENDATIONS**

**DESCRIPTION OF THE WASHING MACHINE**

**DOOR**

**CHILD SAFETY (IF AVAILABLE)**

**BEFORE THE FIRST WASH CYCLE**

**PREPARING THE WASH**

**DETERGENTS AND ADDITIVES**

**REMOVING THE FILTER**

**DRAINING RESIDUAL WATER**

**CARE AND MAINTENANCE**

**TROUBLESHOOTING GUIDE**

**AFTER-SALES SERVICE**

**TRANSPORT/HANDLING**

**ELECTRICAL CONNECTION**

# BEFORE USING THE WASHING MACHINE

## 1. Remove the packaging and check

- After unpacking, make sure that the washing machine is undamaged. If in doubt, do not use the washing machine. Contact After-Sales Service or your local retailer
- Check that the accessories and supplied parts are all present
- Keep the packing material (plastic bags, polystyrene parts, etc.) out of reach of children, as they are potentially dangerous

## 2. Remove the transport bolts

- The washing machine is fitted with a transport bolts to avoid any possible damage to the interior during transport. Before using the washing machine, it is imperative that the transport bolts are removed

## 3. Install the washing machine

- Remove the protective foil from the control panel
- Move the appliance without lifting it by the worktop
- Install the appliance on a solid and level floor surface, preferably in a corner of the room
- Make sure that all four feet are resting firmly on the floor and check that the appliance is perfectly level (use a spirit level)

## 4. Water inlet

- Connect the water supply inlet hose in accordance with regulations of your local water company
- Water inlet: Cold water only
- Tap: 3/4" threaded hose connection
- Water Pressure (flow pressure): 100-1000 kPa (1-10 bar)

## 5. Drain hose

- Connect the drain hose to the siphon or hook it over the edge of a sink by means of the "U" bend supplied
- If the washing machine is connected to a built-in pumping out system, ensure that the latter is equipped with a vent to avoid simultaneous loading and draining of water (siphoning effect)

## 6. Electrical connections

- Electrical connections must be carried out by a qualified technician in compliance with the manufacturer's instructions and local safety regulations
- Data concerning voltage, consumption and fuses are located on the inside of the appliance door
- The appliance must be connected to the mains exclusively by means of a socket with an earth connection in accordance with established regulations. The washing machine must be earthed by law. The manufacturer declines all liability for damage to property or injury to persons or animals due to non-compliance with the directions given above
- Do not use extension leads or multi sockets
- Before any maintenance on the washing machine disconnect it from the mains supply
- Access to the mains plug or to disconnection from mains supply via a double-pole switch must be ensured at all times following the installation
- Do not operate the washing machine if it has been damaged during transport. Inform the After-Sales Service
- Mains cable replacement is only to be carried out by After-Sales Service
- The washing machine must only be used in the household for the prescribed uses

### Minimum housing dimensions:

Width:	600 mm
Height:	825 mm
Depth:	600 mm

# PRECAUTIONS AND GENERAL RECOMMENDATIONS

## 1. Packaging

- The packaging is 100% recyclable and is marked with the  recycling symbol. Adhere to current local regulations when disposing of packaging material

## 2. Disposing of packaging and old washing machines

- The washing machine is built from reusable materials. It must be disposed of in compliance with current local waste disposal regulations
- Before scrapping, remove all detergent residues and cut off the power cable so that the washing machine is made unusable

## 3. General recommendations

- Do not leave the washing machine connected when not in use
- Turn off the tap
- Before any cleaning and maintenance switch off the machine or disconnect it from the mains
- Clean the outside of the washing machine with a damp cloth. Do not use abrasive detergents
- Never open the door forcibly or use it as a step
- Children must not be allowed to play with the washing machine or to climb into the drum (see also the following page chapter "Child Safety")
- If necessary, the power cable may be replaced with an identical one obtained from our After-Sales Service. The power cable must only be replaced by a qualified technician

## 4. EC Declaration of Conformity

- This appliance complies with the EC Directives:  
73/23/EEC Low Voltage Directive  
89/336/EEC EMC Directive  
93/68/EEC CE Marking Directive 

## DESCRIPTION OF THE WASHING MACHINE

1. Worktop
2. Control panel
3. Detergent dispenser
4. After-Service sticker (inside door)
5. Door
6. Child safety (inside door, if available)
7. Filter (inside compartment door)
8. Plinth
9. Adjustable feet

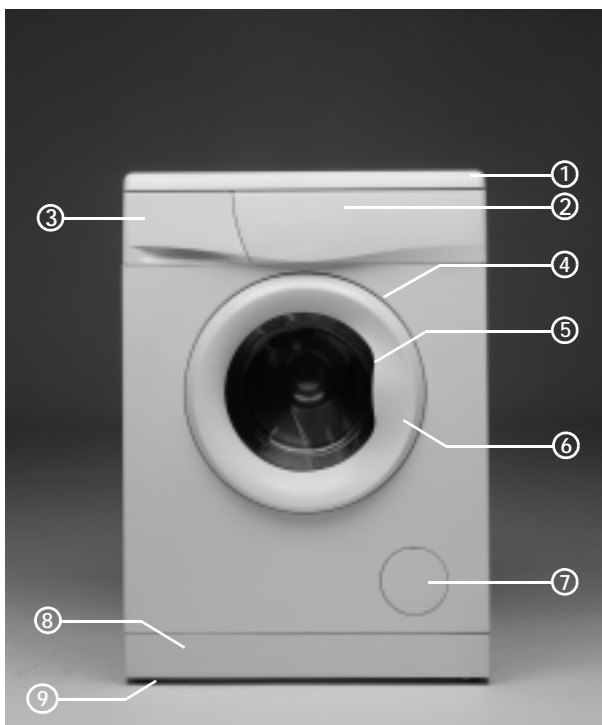

## DOOR

To open the single glass door hold the door handle, press the inside handle and pull the door up. Close the door with light force, it will lock home audibly.



## CHILD SAFETY (IF AVAILABLE)

To secure the appliance against improper use turn the plastic screw on the interior of the door. To do this, use the thick rounded corner of the coloured insert from the detergent dispenser or a coin:

- Slot vertical: the door will not lock
- Slot horizontal: the door can be locked again



## BEFORE THE FIRST WASH CYCLE

To remove any residual water used in testing by the manufacturer, we recommend that you carry out a short wash cycle without laundry.

1. Turn on the tap.
2. Close the door.
3. Pour a little detergent (about 30 ml) into the detergent compartment .
4. Select and start a short programme (see quick reference guide).

## PREPARING THE WASH

### 1. Sort the laundry according to...

- **Type of fabric / care label symbol**  
Cottons, mixed fibres, easy care/synthetics, wool, handwashed items
- **Colour**  
Separate coloured and white items. Wash new coloured articles separately
- **Size**  
Laundry items of different sizes distribute themselves better in the drum and optimise the washing and spinning action
- **Delicates**  
Wash small items (e.g. nylon stockings, belts etc.) and items with hooks (e.g. bras) in a washbag or pillow case with a zip fastener. Always remove curtain glides or wash curtains with the glides inside a cotton bag

### 2. Empty all pockets

Coins, safety pins etc. can damage the laundry, drum and tub

### 3. Closures

Close zips and hooks and eyes; Tie loose belts or straps together

### Stain removal

- Blood, milk, eggs etc. are generally removed by the automatic enzyme phase of the programme
- To remove red wine, coffee, tea, grass and fruit stains etc. add a stain remover to the detergent dispenser  chamber
- Pre-treat heavily-soiled areas with stain remover if necessary

### Dyeing

- Only use dyes that are suitable for washing machines
- Follow the manufacturer's instructions
- Plastic and rubber parts of the washing machine can be stained by dyes

### Loading the laundry

1. Open the door.
2. Unfold the laundry and place it loosely in the drum. Observe the load sizes given in the Quick Reference Guide.  
**Note:** overloading the machine will result in unsatisfactory washing results and creased laundry.
3. Close the door.

# DETERGENTS AND ADDITIVES

## The choice of detergent depends on:

- type of fabric (cottons, easy care/synthetics, delicate items, wool).
- Note:** Use only specific detergents for washing wool
- colour
- the wash temperature
- degree and type of soiling

### Remarks:

Whitish residues on dark fabrics are caused by insoluble compounds used in modern phosphate-free powder detergents. If this occurs, shake or brush out the fabric or use liquid detergents.

Use only detergents and additives specifically produced for domestic washing machines.

When using descaling agents, dyes or bleaches for the pre-wash, make sure that they are suitable for use in domestic washing machines. Descaler could contain components which can attack parts of your washing machine.

Do not use any solvents (e.g. turpentine, benzene). Do not wash fabrics in the machine which have been treated with solvents or flammable liquids.

## Dosage

Follow the dosage recommendations on the detergent pack. They depend on:

- degree and type of soiling
- size of wash
  - full load follow the detergent manufacturer's instructions;
  - half load: 3/4 the amount used for a full load;
  - Minimum load (about 1 kg): 1/2 the amount used for a full load
- water hardness in your area (request information from the water company). Soft water requires less detergent than hard water (refer to water hardness table)

### Notes:

Too much detergent can result in excess foam formation.

The cleaning effect deteriorates.

If the washing machine detects too much foam, it may prevent spinning.

Insufficient detergent may result in grey laundry in time and also calcifies the heating system, drum and hoses.

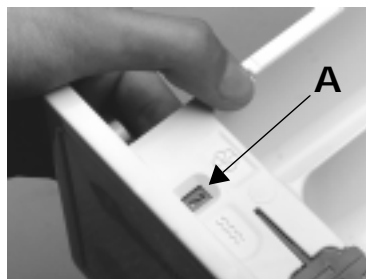

## Water hardness chart

Water hardness	Characteristics	German °dH	French °fH	English °eH
1	soft	0-7	0-12	0-9
2	medium	7-14	12-25	9-17
3	hard	14-21	25-37	17-26
4	very hard	over 21	over 37	over 26

If the machine has a three chamber detergent dispenser, you can set the water hardness level of your household supply (1 to 4) by means of the coloured "pointer" (A). To do this, move the slider on the bottom of the dispenser to the desired position.

## Pouring in the detergents and additives

The dispenser will have three (models "B1" or "B2") or four (model "A") chambers depending on model.

Chamber



- Detergent for the prewash

Chamber



- Detergent for the main wash
- Stain remover
- Water softener (water hardness 4)

When using liquid detergent, remove the coloured insert from the detergent container and insert it in the first gap in chamber . The scale on the insert makes dosing easier.

Chamber



- Fabric Softener
- Liquid starch

Only pour additives in up to the "Max" mark.

Chamber



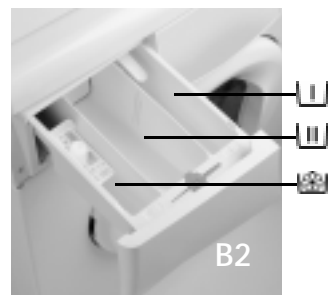
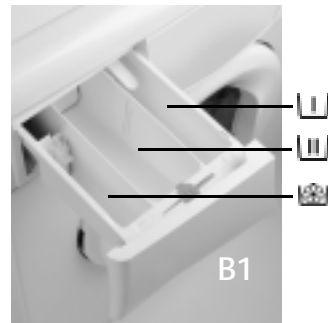
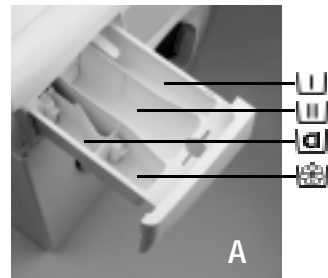

- Chlorine bleach

No more than to the "Max" mark (four chambers model "A")



## Notes:

- Keep detergents and additives in a safe, dry place out of the reach of children.
- Liquid detergents can be used for programmes with prewash. In this case only measure in a powder detergent for the main wash.
- To prevent dispensing problems when using highly concentrated powder and liquid detergents, use the special detergent ball or bag supplied with the detergent and place it directly inside the drum.
- When using descaling agents, bleaches or dyes, make sure that they are suitable for washing machines. Descalers could contain components that can attack parts of your washing machine.
- Do not use any solvents in the washing machine (e. g. turpentine, benzine).
- If you use starch powder, proceed as follows:
  1. Wash your laundry using the desired wash programme.
  2. Then stir the starch in with water in a beaker.
  3. Select the "Rinse and Spin" programme, reduce the speed to ca. 800 rpm and start the programme.
  4. Pull out the detergent drawer until you can see about 3 cm of chamber .
  5. Pour the starch solution into chamber  while the water is running into the detergent drawer.
  6. If there are starch residues in the detergent drawer when the programme has finished, clean it if necessary (see "Cleaning and Maintenance").  
Take note also of the starch manufacturer's information.

## REMOVING THE FILTER

We recommend that you check and clean the filter regularly, at least two or three times a year.

### Especially:

- When the appliance does not drain or spin properly
- If the pump is blocked by a foreign body (e.g. buttons, coins or safety pins)

**IMPORTANT: make sure the water has had time to cool before draining the appliance.**

1. Switch off the appliance and unplug it.
2. Open the filter cover. Open the filter cover with the help of the coloured insert from the detergent container.
3. Place a container beneath it.
4. Open the filter but do not withdraw it completely. Slowly turn the handle anticlockwise until the water drains out.
5. Wait until all the water has drained off.
6. Now unscrew the filter completely and remove it.
7. Clean the filter and the filter chamber.
8. Check that the pump rotor moves freely.
9. Insert the filter with the guide pin upwards and screw it in clockwise to the stop (handle horizontal).
10. Pour about 1 litre of water into the detergent drawer to reactivate the Eco system. Check that the foreign body trap is seated properly and tightly in place.
11. Fold the cover up and lock it.
12. Reinsert the plug in the socket.
13. Select a programme and start it.





## DRAINING RESIDUAL WATER

Before emptying the residual water, switch the appliance off and unplug it from the mains socket.

Open the cover to the foreign body trap. Open the filter cover with the help of the coloured insert from the detergent container. Place a container beneath it.

1. Open the filter but do not withdraw it completely. Slowly turn the handle anticlockwise until the water drains out.
2. Wait until all the water has drained off.
3. Now unscrew the filter completely and remove it.
4. Tilt the appliance forwards carefully to allow the water to flow out.
5. Insert the filter with the guide pin upwards and screw it in clockwise to the stop (handle horizontal).
6. Fold the cover up and lock it.

**Before using the washing machine again:**

1. Pour approx. 1 litre of water into the detergent drawer to reactivate the Eco system.
2. Reinsert the plug in the socket.

## CARE AND MAINTENANCE

### Appliance exterior and control panel

- Can be washed down with a soft, damp cloth
- A little neutral cleaner (not abrasive) can be used
- Dry with a soft cloth

### Door seal

- Clean with a damp cloth when necessary
- Check the seal folds for foreign bodies periodically

### Filter

- We recommend that you check and clean the filter regularly, at least two or three times a year (see "Removing The Filter")

## Detergent dispenser

1. Press the release lever in the prewash compartment downward and remove the drawer.
2. Remove the insert (model "A" and "B1") or siphon (model "B2") from the softener compartment.  
Remove the insert for liquid detergents.  
For model "A" only remove also the siphon from the chlorine bleach compartment.
3. Wash all the parts under running water.
4. Replace the parts and refit the detergent dispenser. Insert the detergent dispenser in the washing machine.

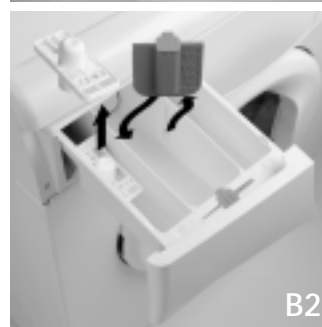
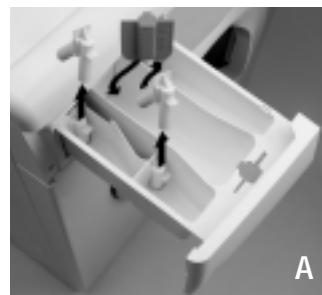

## Mesh Filter in the Water Connection

Check and clean regularly.

For washing machines with a straight inlet hose

1. Turn off the tap and unscrew the water inlet hose from the tap.
2. Clean the internal mesh filter and screw the water inlet hose back onto the tap.
3. Now unscrew the inlet hose on the rear of the washing machine.
4. Pull off the mesh filter from the washing machine connection with universal pliers and clean it.
5. Refit the mesh filter and screw the inlet hose on again.
6. Turn on the tap and ensure that the connections are completely water-tight.

For washing machines with Water Stop hose

1. Turn off the tap and unscrew the Water Stop hose from the tap.
2. Clean the internal mesh filter and screw the water inlet hose back onto the tap.
3. Turn on the tap and ensure that the connection is completely water-tight.



# TROUBLESHOOTING GUIDE

Depending on the model, your washing machine is equipped with various automatic safety functions. This enables faults to be detected in good time and the safety system can react appropriately.

These faults are frequently so minor that they can be solved within a few minutes.

## The appliance will not start, no lamp lights up.

Check whether:

- the mains plug is inserted into the socket;
- the wall socket is functioning correctly (use a table lamp or similar);
- a programme is selected correctly;
- the "On/Off" button (depending on model) has been pressed.

## The appliance will not start, but... (varies depending on model)

### ...the "Start/Pause" lamp is flashing.

Check whether:

- the appliance door is properly closed (child safety);
- the programme has been changed;
- the water tap is open. If not, open the tap and press the "Start/Pause" button.

### ...the "On/Off" lamp is on.

Check whether:

- the appliance door is properly closed (child safety);
- a programme has been selected and the programme is started;
- the water tap is open. If not, open the tap and switch the appliance first off, then on.

## The appliance stops during the programme (varies depending on model).

Check whether:

- the "Rinse Hold" lamp is on, terminate this option by pressing the button again;
- another programme has been selected. Reselect the desired programme and press the "Start/Pause" button;

## What should I do when the automatic safety system detects a malfunction? (varies depending on model)

The programme is interrupted and various indicators (if available) point to the source of the fault.

### Fault description table

Small lamp lights up	Digital display	Fault description
"Water tap"	"FH"	"Water inlet fault"
-	"FP"	"Draining fault"
-	from "F4" to "F15"	"Electrical components fault"
"Water Stop"	"FA"	"Water Stop fault"

- "Start/Pause" lamp is flashing. Press "Start/Pause" button;
- the "Rinse Hold" button is pushed, terminate this option by pressing the button again;
- "On/Off" lamp is off. Press "On/Off" button;
- the washing machine safety system has been activated (see fault description table).

## Detergent and additive product residues in dispenser at end of wash.

Check whether:

- the siphon is correctly installed and clean (see "Care and Maintenance");
- enough water is being supplied. The mesh filters between the inlet hose and the tap could be blocked (see "Care and Maintenance"). Check and clean the filter two or three times a year (see "Removing the filter").

## The appliance vibrates during the spin cycle.

Check whether:

- the appliance is levelled and solidly installed on all four feet (see "Installation Guide");
- the transit bolts have been removed. The transit bolts must be removed before the appliance can be used (see "Installation Guide").

## Final spin results are poor:

The appliance has an imbalance detection and correction system. If individual heavy articles are loaded (bathmat, bathrobe, etc.) this system may reduce the spin speed automatically to protect the appliance or even interrupt the spin cycle altogether, if the imbalance is too high even after several spin starts.

- If the laundry is still too wet at the end of the cycle, add smaller articles of laundry to balance the load and repeat the spin cycle.
- Excessive foam formation may prevent spinning. Ensure correct amount of detergent is used

## No water or insufficient water supply:

- the appliance has a safety hose and the safety valve has opened (red indicator in the safety valve inspector window). In this case replace it with a new safety hose.

### a. Water inlet fault (no or insufficient water supply)

For models with a fault display, the “Water tap” indicator is on or the display alternately shows “FH”. Switch off the appliance by turning the programme selector to the “” position and unplug it.

For models with no fault display, the washing machine stops in the appropriate step. Switch off the appliance and unplug it.

Check whether:

- the water tap is completely open, and the water supply pressure is sufficient;
- the water inlet hose is kinked;
- the mesh filters are blocked (see “Care and Maintenance” / “Water Hose Mesh Filters”);
- the water inlet hose is frozen.

Reconnect the appliance to the electrical supply.

For models with a fault display, reselect the desired programme and press the “**Start/Pause**” button again to continue with the programme (do not add detergent for this programme).

For models without a fault display continue the programme by pressing the “**On/Off**” button again (do not add detergent for this programme).

If the fault re-occurs, contact After-Sales Service (see “After-Sales Service”).

### b. Draining out fault

For models with a fault display, depending on the model, the display shows statically or alternately “FP”. Switch off the appliance by turning the programme selector to the “” position and unplug it.

For models with no fault display, the washing machine stops in the appropriate step. Switch off the appliance and unplug it.

Check whether:

- the drain hose is kinked (see “Installation Guide”);
- the pump / filter are blocked (see “Removing the Filter / Draining Residual Water”);

**IMPORTANT:** before draining, allow the wash water to cool down.

- the drain hose is frozen.

Connect the appliance to the electrical supply.

For models with a fault display reselect the desired programme and press the “**Start/Pause**” button again to continue with the programme (do not add detergent for this programme).

For models without a fault display continue the programme by pressing the “**On/Off**” button again (do not add detergent for this programme).

If the fault re-occurs, contact After-Sales Service (see “After-Sales Service”).

### c. Electrical module fault

For models with a fault display “F4” to “F15” are displayed and some or all Spin Speed Selection LEDs are flashing. Switch off the appliance. Select a programme and press the “**Start/Pause**” button once again. The programme will continue.

For models without a fault display the washing machine stops in the appropriate step. Switch the appliance first off, then on. The programme will continue.

If the fault re-occurs, contact After Sales Service (See “After-Sales Service”).

### d. Water Stop fault (if available)

The “Water Stop” may have been triggered by:

1. too much foam.
2. a leak in the inlet hose or in the appliance.

In this case the pump is switched on automatically in order to pump the water out.

For models with a fault display the light of the “Water Stop” indication is on. The display shows “FA” or alternately “F” and “A” and the pump is running. Switch off the appliance by turning the programme selector to the “” position, unplug the appliance and make sure that the water tap is closed.

For models without a fault display the washing machine stops in the appropriate step. Switch off the appliance, , unplug the appliance and make sure that the water tap is closed.

Tilt the appliance forwards carefully to allow the collected water to flow out.

Then:

1. plug in the appliance,
2. turn the water tap on (if water immediately flows into the appliance again, without the appliance being started, close water supply and call After-Sales Service).

For models with a fault display reselect the desired programme and press the “**Start/Pause**” button again to continue with the programme (do not add detergent for this programme).

For models without a fault display continue the programme by pressing the “**On/Off**” button again (do not add detergent for this programme).

If the fault re-occurs, contact After-Sales Service (see “After-Sales Service”).

## AFTER-SALES SERVICE

### Before contacting After-Sales Service:

1. Try to remedy the problem yourself (see "Troubleshooting Guide").
2. Restart the programme to check whether the problem has solved itself.
3. If the washing machine continues to function incorrectly, call After-Sales Service.

### Specify:

- The nature of the problem.
- The washing machine model.
- The service code (number after the word SERVICE).

**SERVICE** 0000 000 00000



The After-Sales Service sticker is on the inside of the door.

- Your full address.
- Your telephone number and area code.  
After-Sales Service numbers and addresses can be found in the guarantee booklet or contact the dealer.

## TRANSPORT/HANDLING

### Never lift the appliance by the worktop when transporting.

1. Pull out the power plug.
2. Turn off the tap.
3. Remove the water supply and drain hose.
4. Drain residual water from the appliance and hoses (see "Removing The Filter"/"Draining Residual Water").
5. Fit the transit bolts (obligatory)

## ELECTRICAL CONNECTION

### For Great Britain only

**Warning - this appliance must be earthed**

#### Fuse replacement

If the mains lead of this appliance is fitted with a BS 1363A 13amp fused plug, to change a fuse in this type of plug use an A.S.T.A. approved fuse to BS 1362 type and proceed as follows:

1. Remove the fuse cover (A) and fuse (B).
2. Fit replacement 13A fuse into fuse cover.
3. Refit both into plug.

#### Important:

The fuse cover must be refitted when changing a fuse and if the fuse cover is lost the plug must not be used until a correct replacement is fitted.

Correct replacement are identified by the colour insert or the colour embossed in words on the base of the plug.

Replacement fuse covers are available from your local electrical store.

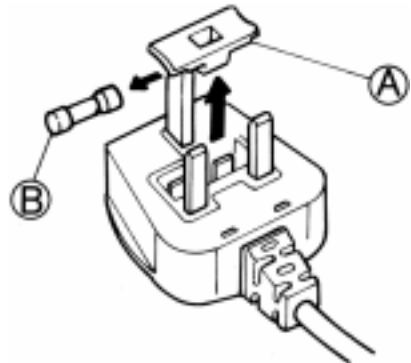

### For the Republic of Ireland only

The information given in respect of Great Britain will frequently apply, but a third type of plug and socket is also used, the 2-pin, side earth type.

#### Socket outlet / plug (valid for both countries)

If the fitted plug is not suitable for your socket outlet, Please contact Whirlpool Service for further instruction. Please do not attempt to change plug yourself. This procedure needs to be carried out by a qualified Whirlpool technician in compliance with the manufactures instructions and current standard safety regulations.